

**NOTICE D'INSTALLATION ET D'UTILISATION
SALAMANDRES ELECTRIQUES**

**INSTRUCTION FOR USE AND INSTALLATION
ELECTRIC SALAMANDERS**

SEM 600 /SEM 800 / SEF 800



Fabrication Française

Made in France

Novembre 2016

SALAMANDERS SEM 600/SEM 800/SEF 800

Congratulations for the acquisition of this upmarket appliance made in France. You chose an appliance which alloys the best technical qualities with a big user-friendliness. We wish you the biggest contentment.

1. SECURITY INSTRUCTIONS

Please respect these instructions scrupulously to avoid any risk of fire, electric shock, scald or other wounds and damage. During the use of this appliance, fundamental circum-spection of security must always be noticed, such as:

- Take into account the instructions to be systematically kept with the appliance.
- Install the appliance always in instructions respect. A 50 cm distance minimum with the partition or the wall is necessary.
- Protect the appliance from direct light of the sun, frost and humidity.
- Never leave the appliance within the reach of children or disabled persons without surveillance.
- Ensure that only trained personnel operate the appliance.
- Never move the appliance when it is working or when the cooking surfaces are still hot.
- Check that the appliance is definitely off before connecting it up or disconnecting it.
- Do not touch the hot surfaces of the appliance. The temperature of the hot surfaces can be very important when the appliance is working.

Always use handles and control knobs.

- Do not use the appliance for other functions than determined use.
- Do not leave the cord of electrical feeding in the contact of hot surfaces.
- The appliance should not be used close to combustible materials.
- During use, look after not to obstruct hearings of aeration of the appliance.
- To avoid any electric shock, never plunge the appliance, the cord or plug in water or quite other liquid.
- If the cord is harmed, it must be replaced by the producer, his after sale service or persons of similar skills to avoid any risk.
- Entrust compensations only to a skilled person.
- Use only spare parts of origin.
- At the end of cooking, before cleaning the appliance, do not forget to disconnect it.

2. CONTENTS OF CARDBOARD PACKAGING

Device: a salamander

Accessories: - A tray

- A grid

- A grid with handles (SEF 800)

- A quartz tubes protection grid (only for quartz salamanders)

- The present note

See exploded views for each models at the end of the document

3. CONFORMITY OF USE

Use the device only to defrost, brown, glaze, grill toasts, gratins, pizzas, onion soups... without pre-heating.

4. WAY OF FUNCTIONING

These salamanders exist in 11 versions (8 electric versions and 3 gas versions)

SALAMANDERS WITH MOVABLE TOP

Salamanders SEM 600 and SEM 800 are respectively fitted with two or three cooking areas, a removable inside tray and a commutator to select power.

The top of the salamander is movable and enables you to adapt the cooking position to grill, glaze or brown your foodstuffs.

FIXED SALAMANDERS

Salamanders SEF 800 are fitted with three cooking areas, a removable inside tray, two racks enabling to adjust the grid with handles on 3 levels to adapt cooking position.

To turn on the salamander, just turn the commutator control knob (n°2 on picture) on the wished position according to desired cooking zone. The control pilot light ignites (n°1 on picture), regarding the selected cooking area.

the device is on and the orange pilot light ignites (n°2 on picture), plate is heating. When orange pilot light switches off, the device is ready for the cooking.

Position 1 : Left area
Position 2 : Right area
Position 3 : Complete area.



- 1** Control pilot light
- 2** Commutator

5. FUNCTIONING / MANIPULATION

a) Installation / assembly:

- Unpack carefully the device of its packaging.
- Place the salamander on a plane and heatproof surface.
- Never place the device near a wall or near a partition made of combustible materials even if it is very well isolated.
- A distance of minimum 40 cm with the partition or the wall is necessary.
- Remove the protective film from the top, the rear, the sides and the tray.
- Unlock the movable top by unscrewing the screw located on the back of the machine thanks to a 10 pipe key (models SEM).
- In case of connection directly to the electrical network, a disconnection mode has to be planned in conformity with the norms.

CAUTION :

During use: never place the machine on surfaces or near walls, partitions or kitchen furniture and similar— except if they are made with a non combustible material or recovered with non combustible thermic insulation, and pay attention to fire preventions rules.

b) First starting:

During the first use, warm your machine up outside to evacuate residual smokes of manufacturing oil from the metallic parts. This may emit a slight smell for a few moments.

First cleaning

Clean the device before the first use. (See 6. Cleaning)

Connection of the device

- Check that the tension and the frequency of the electricity network suit to the values indicated on the descriptive plate.
- Check that neither the cord nor the plug are damaged. If necessary, it has to be replaced by the manufacturer, its after sale service or any qualified person to avoid any risk.
- Make sure that every control knob is positioned on 0.
- Unwind completely the electric power cable and connect it in a plug connected with the earth.
- The device is connected.

NB: in case of connection of the device in a plug without earth protection or directly on the electricity network, confide its connection to a qualified person .

c) Use of device :

Elements of command and display

Command/Display	Function
Pilot light (n°1 on picture)	On/off for each cooking area (pilot light on)
Commutator 4 positions (n°2 on picture)	Regulate the power according to below scheme

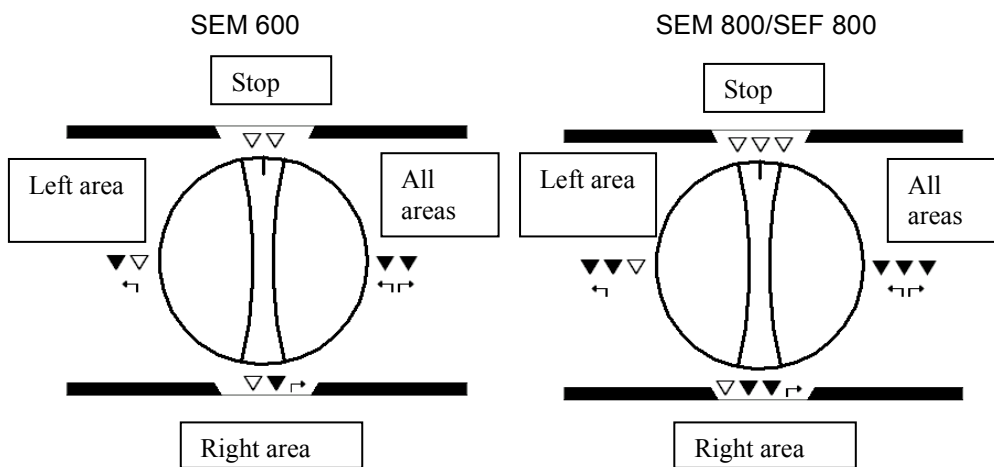

Putting on

Turn on the commutator control knob (n°2 on picture) on wished position according to desired cooking power. The pilot light (n°1 on picture) ignites

The cooking with infrared radiation (quartz tube and glass ceramic) do not need pre-heating.

Stopping the appliance

- Set the commutator control knob on 0
- Disconnect the power cable.
- Let the device cool it down
- Clean the appliance. (see 6. Cleaning)

d) Breakdown / repair:

In case of breakdown or of damaged part, please call your after-sales service and confide any technical operation to qualified person.

When you contact the after-sales service of your distributor or your store, give him the complete reference of your device (commercial name, type and serial number).

This information appears on the visible descriptive plate behind the device.

6. CLEANING AND MAINTENANCE

Disconnect the device.

- Let cool completely the device before any technical intervention or cleaning.
- Never clean the quartz tubes when they are hot
- Avoid touching quartz tubes with your fingers but use a cloth moistened with spirit.
- Clean regularly the external walls of your device with warm water and wash liquid: avoid the abrasive towelling. Rinse your device with a wet sponge.
- Never clean the device under a water jet, the infiltrations would risk to damage it in a irreparable way.
- Never immerse the device, the cord or the plug in the water or quite other liquid to avoid any electric shock.
- During a prolonged non-use, we recommend you strongly to keep the device shielded from the humidity.

7. TECHNICAL SPECIFICATIONS

Models	SEM 600 B	SEM 600 Q	SEM 600 VC	SEM 800 B	SEM 800 Q	SEM 800 VC	SEF 800 B	SEF 800 Q
Voltage	220-240 V ~	220-240 V ~	220-240 V ~	380-415 V 3 N ~	380-415 V 3 N ~	380-415 V 3 N ~	380-415 V 3 N ~	380-415 V 3 N ~
Current	13 A	13 A	13 A	6.5A/Phase	6.5A/ Phase	6.5A/ Phase	6.5 A/Phase	6.5 A/Phase
Power	3000 W	3000 W	3000W	4500 W	4500 W	4500 W	4500 W	4500 W
Weight	44 Kg	44 Kg	44 Kg	57 Kg	57 Kg	57 Kg	40 Kg	40 Kg
Nb element	2	8	2	3	12	3	3	12
Cooking surface	495x375 mm	495x375 mm	495x375 mm	740x375 mm	740x375 mm	740x375 mm	740x375 mm	740x375 mm
Outside dimensions	600x590x590	600x590x590	600x590x590	800x590x590	800x590x590	800x590x590	800x590x590	800x590x590

Wires colours correspondance	Phase 1	Brown
	Phase 2	Black
	Phase 3	Grey
	Neutral	Blue
	Earth	Yellow-Green

The equipotential connection marked by this symbol  must be linked with the equipotential conductive connection of your installation by means of a minimum conduction of a 2.5 mm² section.

8. NORMS AND LEGALS DISPOSALS

The device is conform to :

IEC/EN 60335-1
 IEC/EN 60335-2-48
 EN 55014-1 + 55014-2
 EN 61000-3-2 + 61000-3-3

Humidity protection degrees IPX3, in conformity with the norm 60335-2-48 (2008)

9. ELIMINATION OF THE ELECTRIC AND ELECTRONIC WASTE

The device respects the directives:

2002/96/CE (DEEE) N°34270064800021
 2002/95/CE (ROHS)
 2066/95 CE
 2004/108 CE



Reach rule

Never put the device among household waste.
 The device must be put down in a centre of recycling for the electric equipments.
 The materials of the device are indeed reusable. By eliminating correctly the electric and electronic wastes, the recycling and quite other shape of re-use of worn equipments, you participate in a significant way in the environmental protection.
 For any information about the collection of electric and electronic waste, please contact your distributor.

10. GUARANTEE

Conditions of guarantee

The guarantee applicable to any device is the commercial guarantee of the distributor or the retailer. Please contact the store where you bought your device to know the precise conditions.

The guarantee grants no right for damages.

The dispositions which follow are not exclusive of the profit of the legal guarantee planned by articles 1641 and following ones of the Civil code relative to the defects and the latent defects.

Exclusion clauses of the guarantee

Bad installation and bad maintenance, in particular if they do not respect current regulations or instructions appearing in this user guide.

Cannot benefit from the guarantee the repairs required as a result of false operations, of inappropriate use, of carelessness or of excess loads of the device, as well as those resulting from variations of the power supply, over tension or from defective installations.

The damage due to shocks, bad weather is not flatware by the guarantee. The material travels at the risks of the user; in case of delivery by carrier, the consignee has to have reservations towards the carrier before any delivery of the device.

The guarantee comes to an end in case of intervention, of repair, of modification by no qualified persons, or of use in inappropriate purposes.

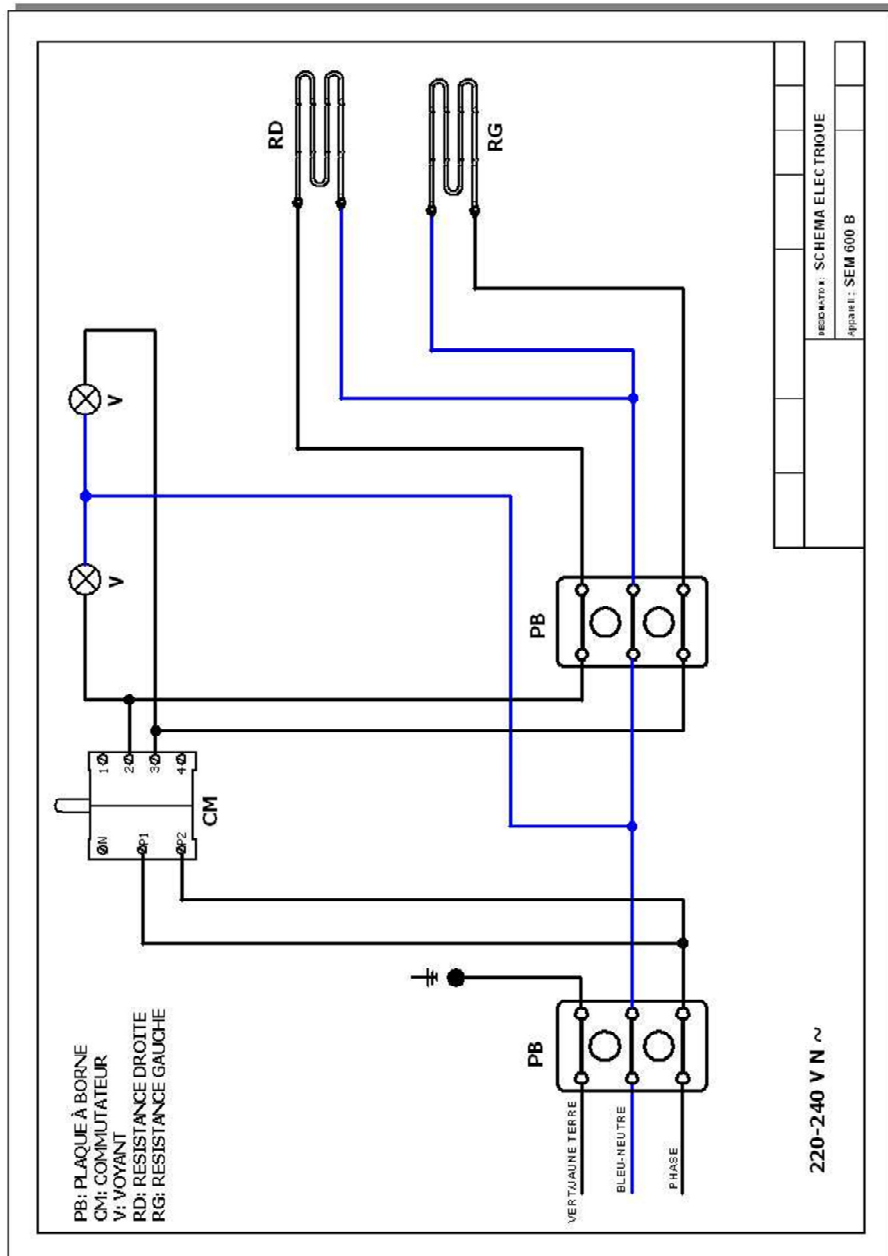

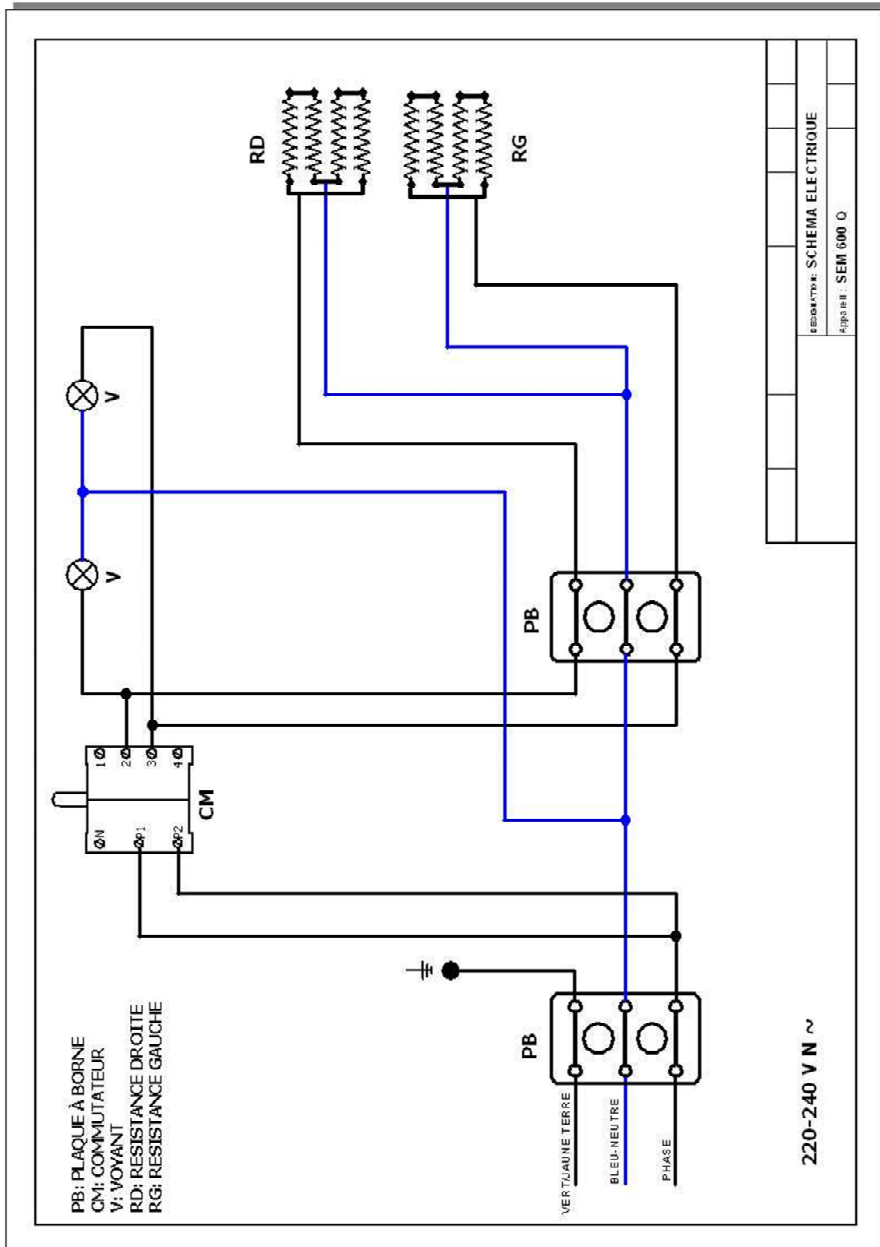

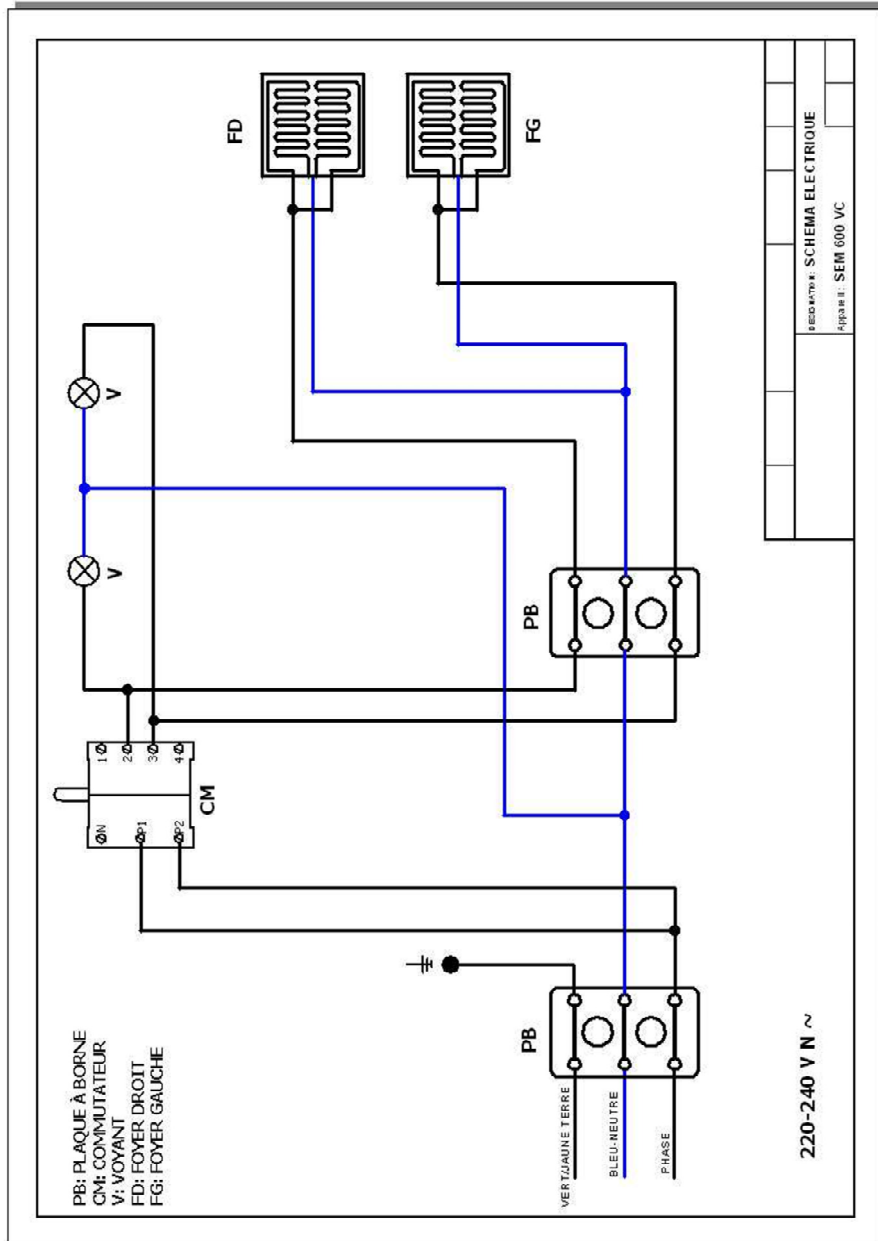

PROJET N° :		SCHEMA ELECTRIQUE	
Appareil :		SEM 600 VC	

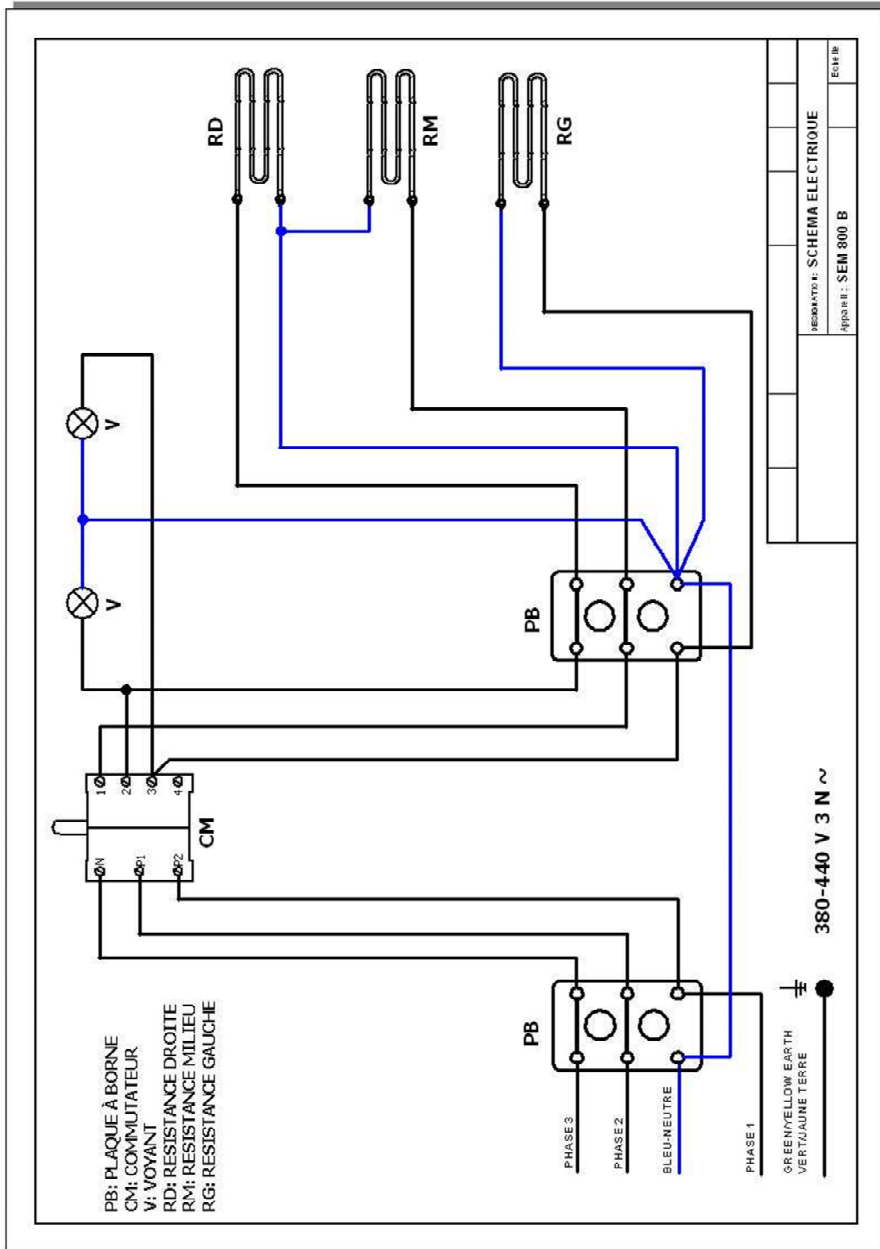

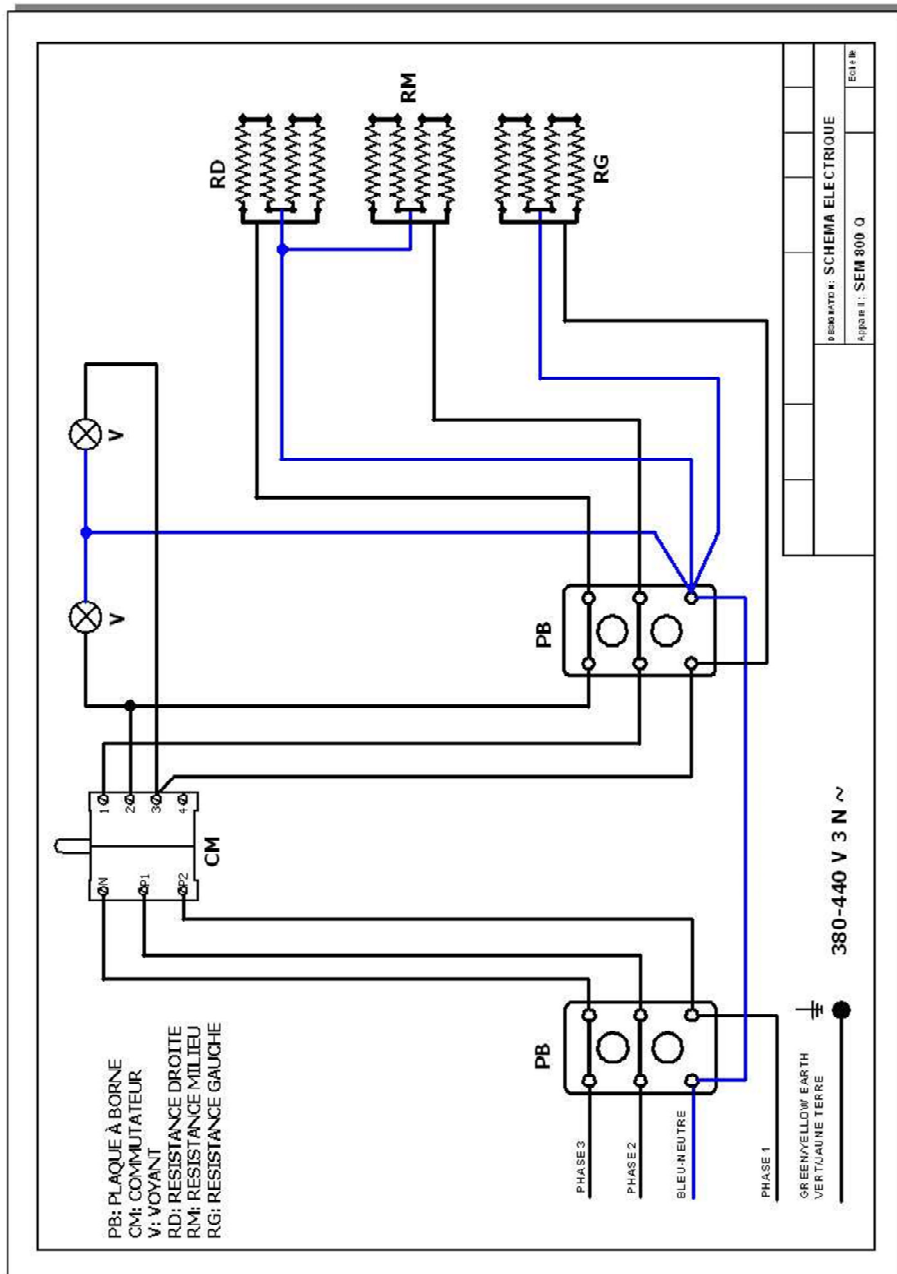

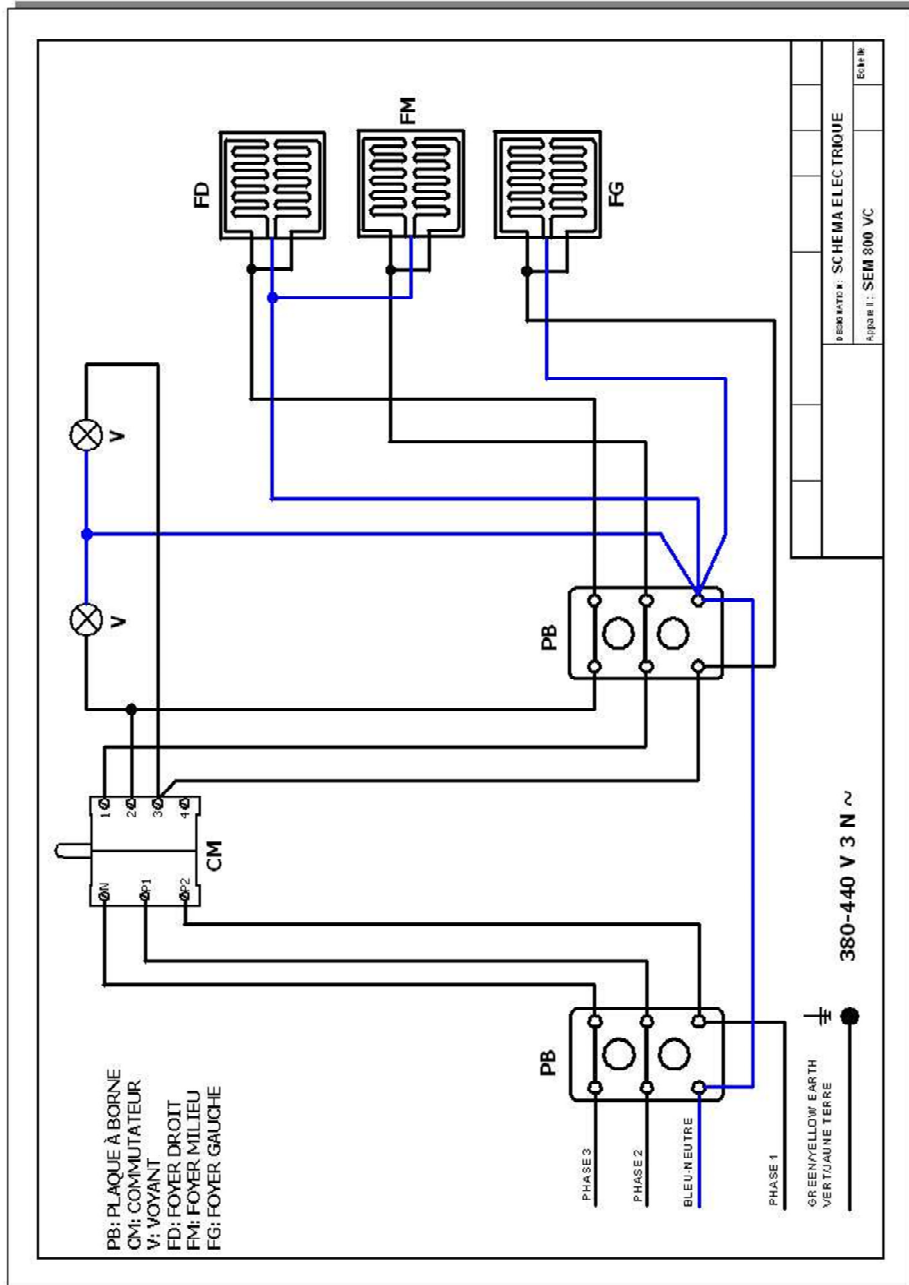

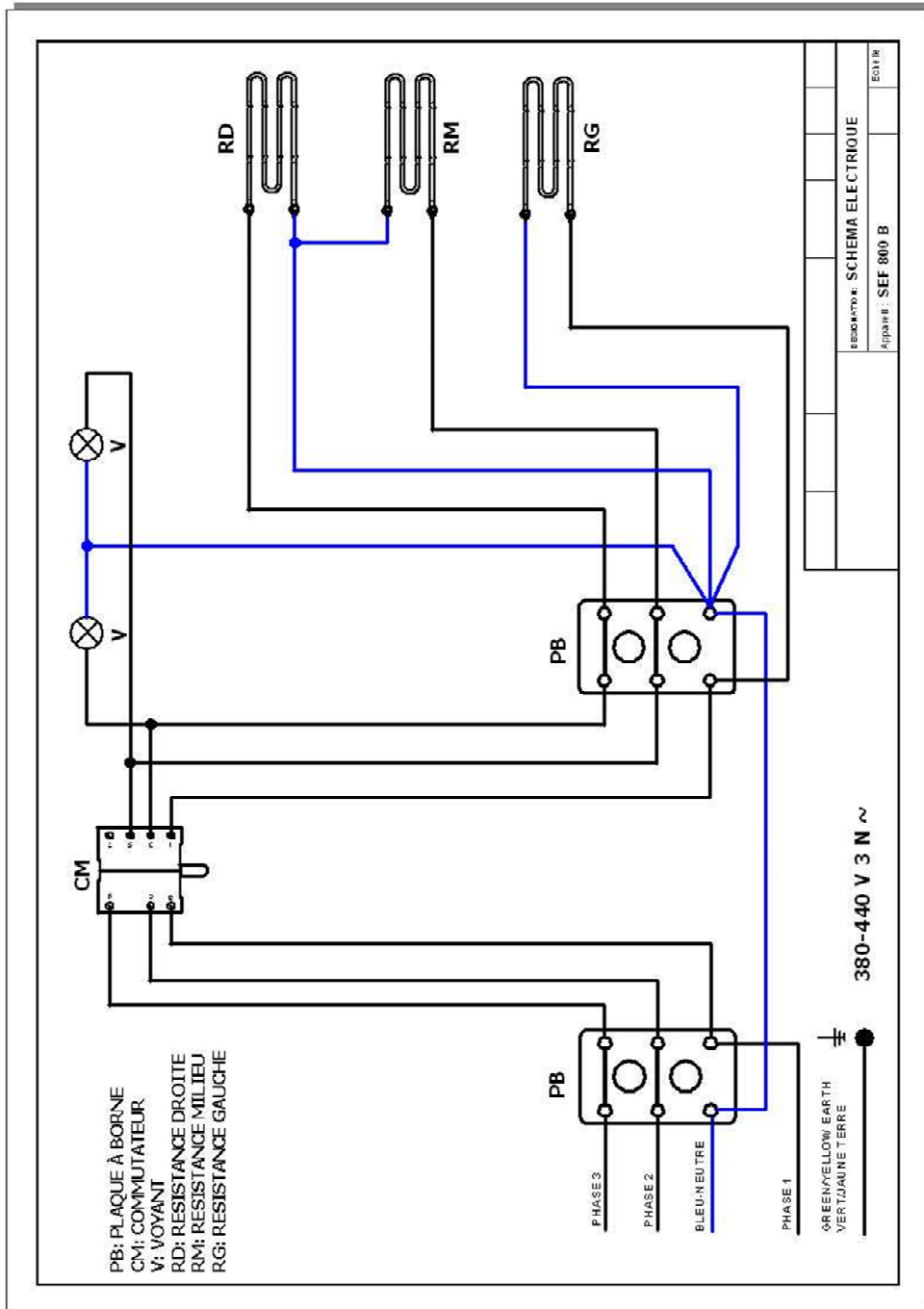

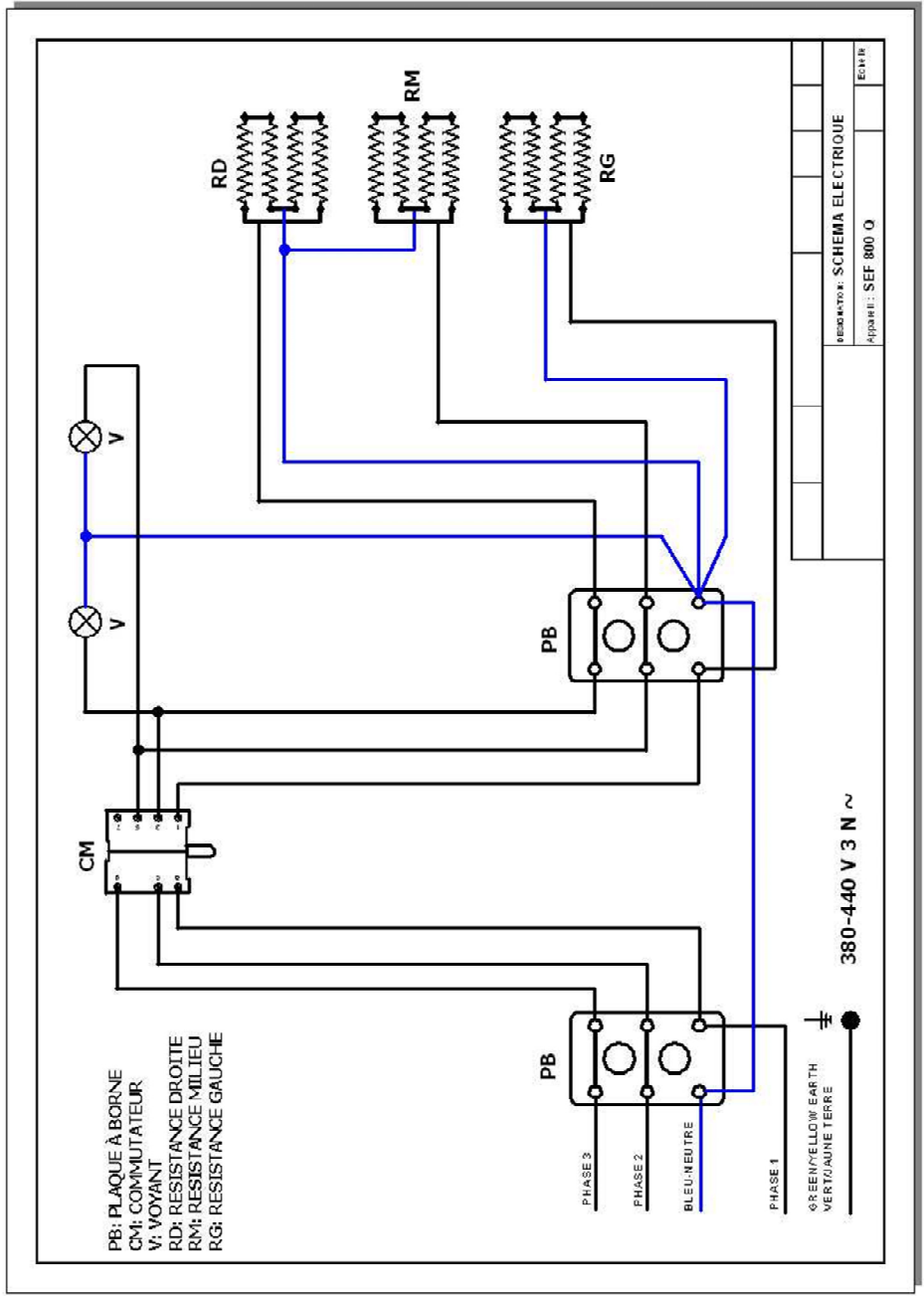

Nomenclature SEM 600 Résistance blindée
Spare parts SEM 600 Armoured heating element

Rep	Code	Qty	Pièce	Spare part
1	70112	1	Toit	Roof
2	A15018	1	Poignée	Handle
3	70103	1	Réflecteur	Reflector
4	D02162	2	Résistance blindée	Armoured heating element
5	A14078	1	Bouton 12 H	Knob 12 H
6	A06003	2	Voyant orange	Orange pilot light
7	A01001/1	1	Commutateur	Commutator
8	F02007	2	Glissière plat	Tray slide
9	70105	1	Plat	Tray
10	F01071	1	Grille	Grid
11	C03013	1	Cable	Cord
12	A10032	1	Serre cable	Cord closer
13	A13006	4	Pied	Foot
14	A16010	2	Plaque à borne	Plate for terminal
15	70102	1	Fond de socle	Bottom casing
16	B06017	10	Roulement	Ball bearing
17	B01002	4	Pignon	Gear wheel
18	B07004	2	Ressort	Spring
19	B07028	2	Chaîne	Chain
20	70094	1	Contre poids	Against weight
21	70098	1	Fond arrière	Back casing

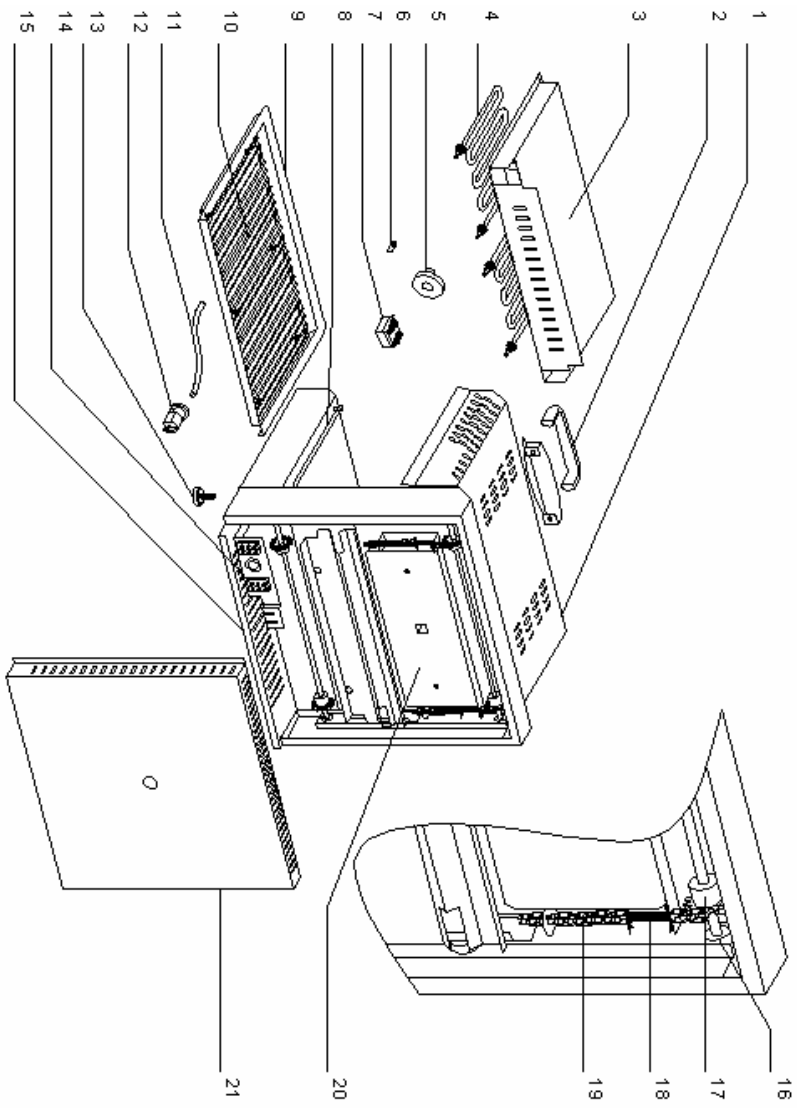

Nomenclature SEM 600 Tube quartz
Spare parts SEM 600 Quartz tube

Rep	Code	Qty	Pièce	Spare part
1	70112	1	Toit	Roof
2	A15018	1	Poignée	Handle
3	70107SE	1	Réfecteur	Reflector
4	F01072	1	Grille protège tube	Tube protection grid
5	A09003COM	16	Steatite complète	Steatite assembly
6	D01045	8	Résistance	heating element
7	D04015	8	Tube quartz	Quartz tube
8	A14078	1	Bouton 12 H	Knob 12 H
9	A08003	2	Voyant orange	Orange pilot light
10	A01001/1	1	Commutateur	Commutator
11	F02007	2	Glissière plat	Tray slide
12	70105	1	Plat	Tray
13	F01071	1	Grille	Grid
14	C03013	1	Cable	Cord
15	A10032	1	Serre cable	Cord closer
16	A13006	4	Pied	Foot
17	A16010	2	Plaque à borne	Plate for terminal
18	70102	1	Fond de socle	Bottom casing
19	B06017	10	Roulement	Ball bearing
20	B01002	4	Pignon	Gear wheel
21	B07004	2	Ressort	Spring
22	B07028	2	Chaîne	Chain
23	70094	1	Contre poids	Against weight
24	70098	1	Fond arrière	Back casing

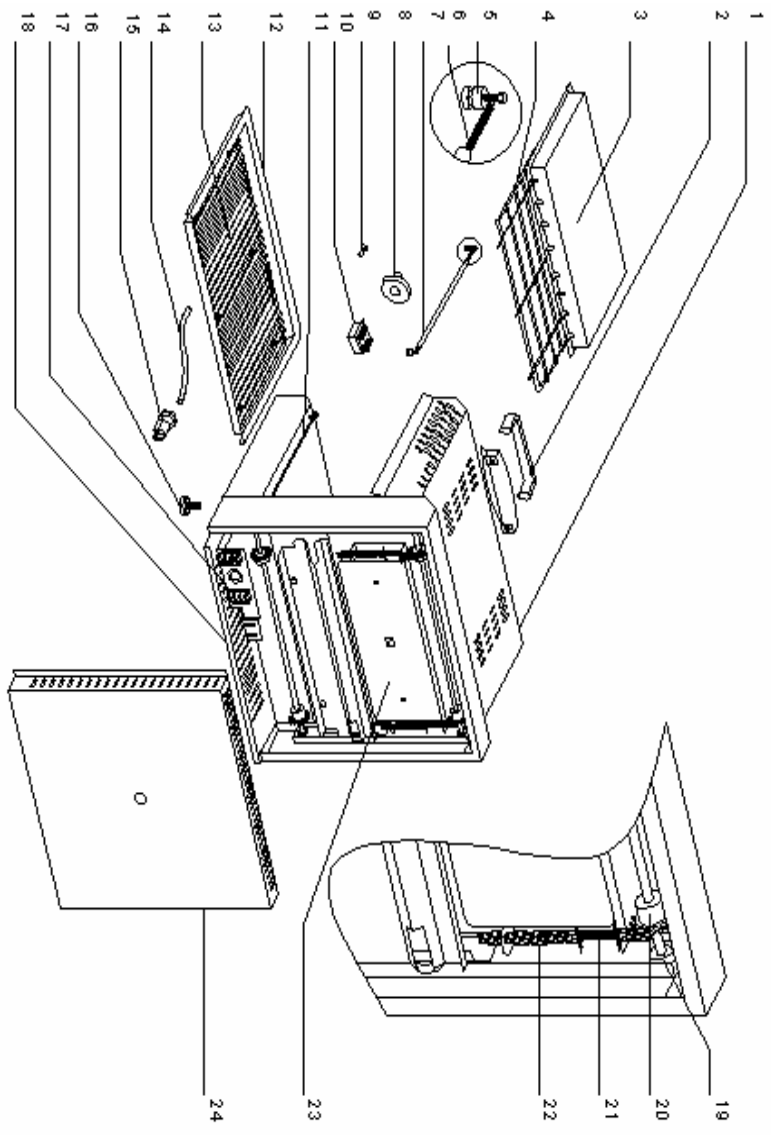

Nomenclature SEM 600 VC
Spare parts SEM 600 VC

Rep	Code	Qty	Pièce	Spare part
1	70112	1	Toit	Roof
2	A15018	1	Poignée	Handle
3	70130	1	Réflecteur	Reflector
4	H01073	1	Glace	Glass
5	D06009	2	Foyer	Ceramic chamber
6	A14078	1	Bouton 12 H	Knob 12 H
7	A08003	2	Voyant orange	Orange pilot light
8	A01001/1	1	Commutateur	Commutator
9	F02007	2	Glissière plat	Tray slide
10	70105	1	Plat	Tray
11	F01071	1	Grille	Grid
12	C03013	1	Cable	Cord
13	A10032	1	Presse étoupe	Cord closer
14	A13006	4	Pied	Foot
15	A16010	2	Plaque à borne	Plate for terminal
16	70102	1	Fond de socle	Bottom casing
17	B06017	10	Roulement	Ball bearing
18	B01002	4	Pignon	Gear wheel
19	B07004	2	Ressort	Spring
20	B07028	2	Chaîne	Chain
21	70114	1	Contre poids arrière	Back against weight
22	70094	1	Contre poids	Against weight
23	70098	1	Fond arrière	Back casing

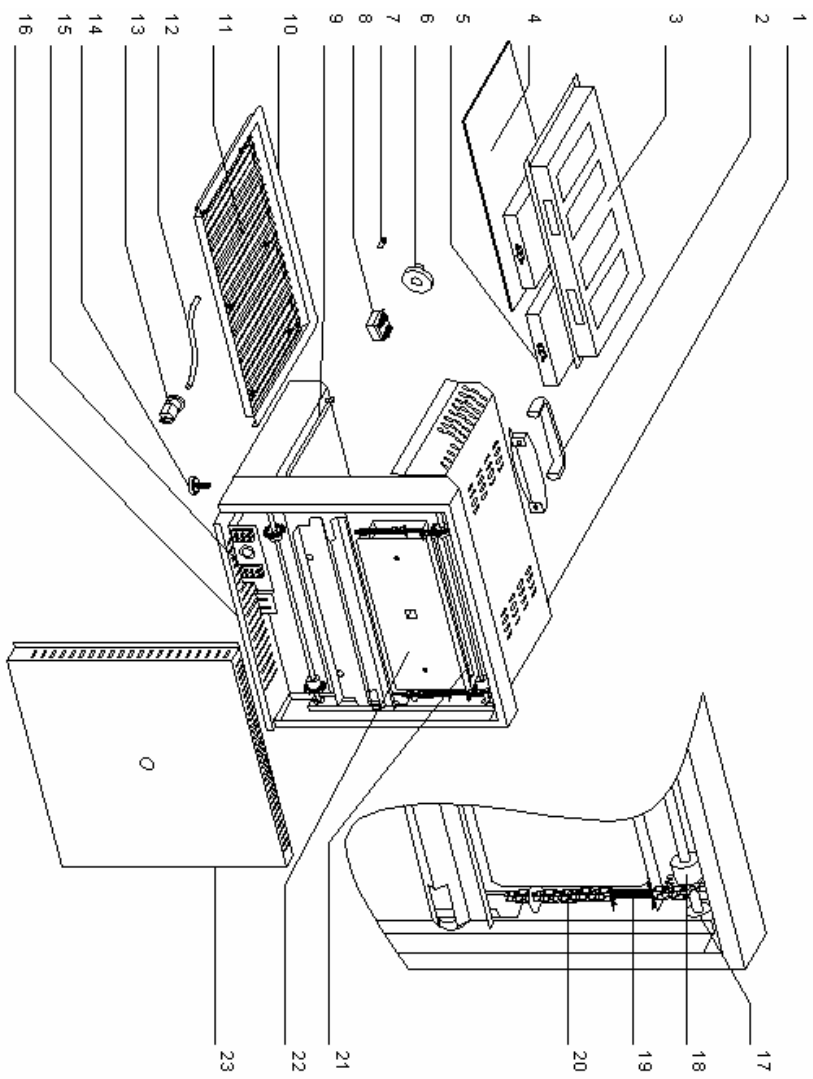

Nomenclature SEM 800 Résistance blindée
Spare parts SEM 800 Armoured heating element

Rep	Code	Qty	Pièce	Spare part
1	72076	1	Toit	Roof
2	A15018	1	Poignée	Handle
3	72057	1	Réflecteur	Réflector
4	D02162	3	Résistance blindée	Armoured heating element
5	A14078	1	Bouton	Knob
6	A08003	2	Voyant orange	Orange pilot light
7	A01001/1	1	Commutateur	Commutator
8	F02007	2	Glissière plat	Tray slide
9	72065	1	Plat	Tray
10	F01068	1	Grille	Grid
11	C01018	1	Cable	Cord
12	A10032	1	Serre cable	Cord closer
13	A13006	4	Pied	Foot
14	A16010	2	Plaque à borne	Plate for terminal
15	72056	1	Fond socle	Bottom casing
16	B06017	10	Roulement	Ball bearing
17	B01002	4	Pignon	Gear wheel
18	B07004	2	Ressort	Spring
19	B07028	2	Chaîne	Chain
20	72077	1	Contre poids	Against weight
21	72055	1	Fond arrière	Back casing

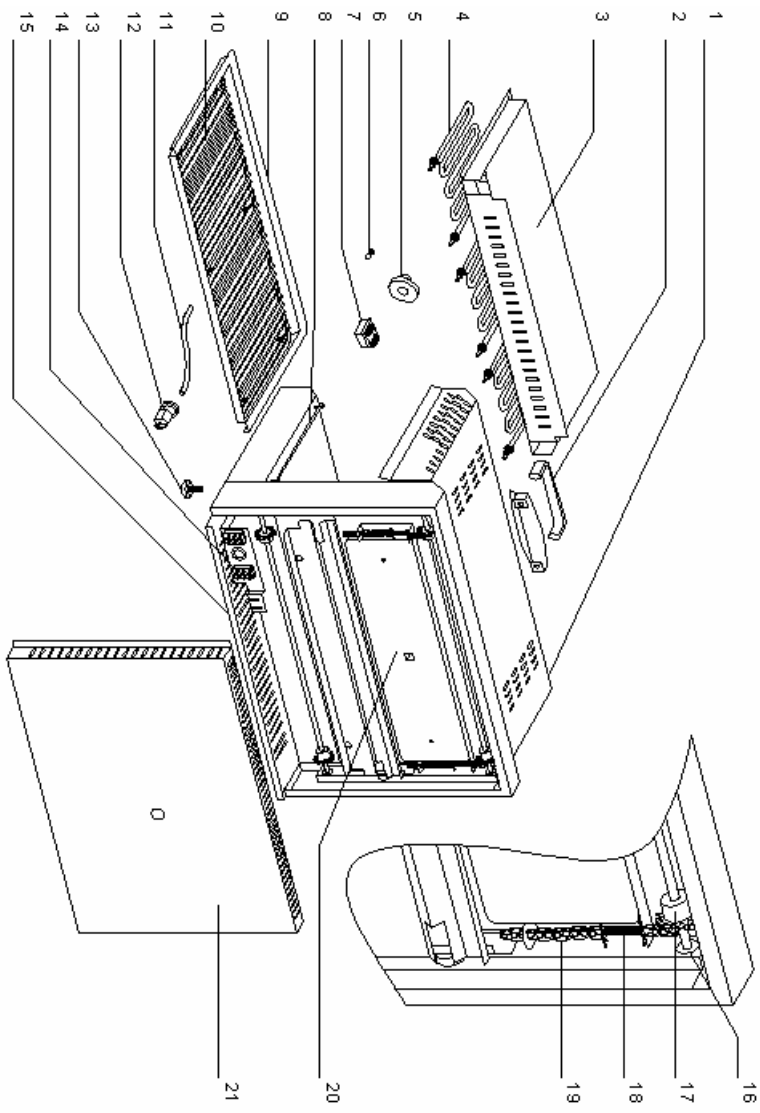

Nomenclature SEM 800 Tube quartz
Spare parts SEM 800 Quartz tube

Rep	Code	Qty	Pièce	Spare part
1	72076	1	Toit	Roof
2	A15018	1	Poignée	Handle
3	72068SE	1	Réflecteur	Réflector
4	F01067	1	Grille protège tube	Tube protection grid
5	A09003COM	24	Steatite complète	Steatite assembly
6	D01045	12	Résistance	Heating element
7	D04015	12	Tube quartz	Quartz tube
8	A14078	1	Bouton	Knob
9	A08003	2	Voyant orange	Orange pilot light
10	A01001/1	1	Commutateur	Commutator
11	F02007	2	Glezière plat	Tray slide
12	72065	1	Plat	Tray
13	F01068	1	Grille	Grid
14	C01018	1	Cable	Cord
15	A10032	1	Serre cable	Cord closer
16	A13006	4	Pied	Foot
17	A16010	2	Plaque à borne	Plate for terminal
18	72056	1	Fond socle	Bottom casing
19	B06017	10	Roulement	Ball bearing
20	B01002	4	Pignon	Gear wheel
21	B07004	2	Ressort	Spring
22	B07028	2	Chaîne	Chain
23	72077	1	Contre poids	Against weight
24	72055	1	Fond arrière	Back casing

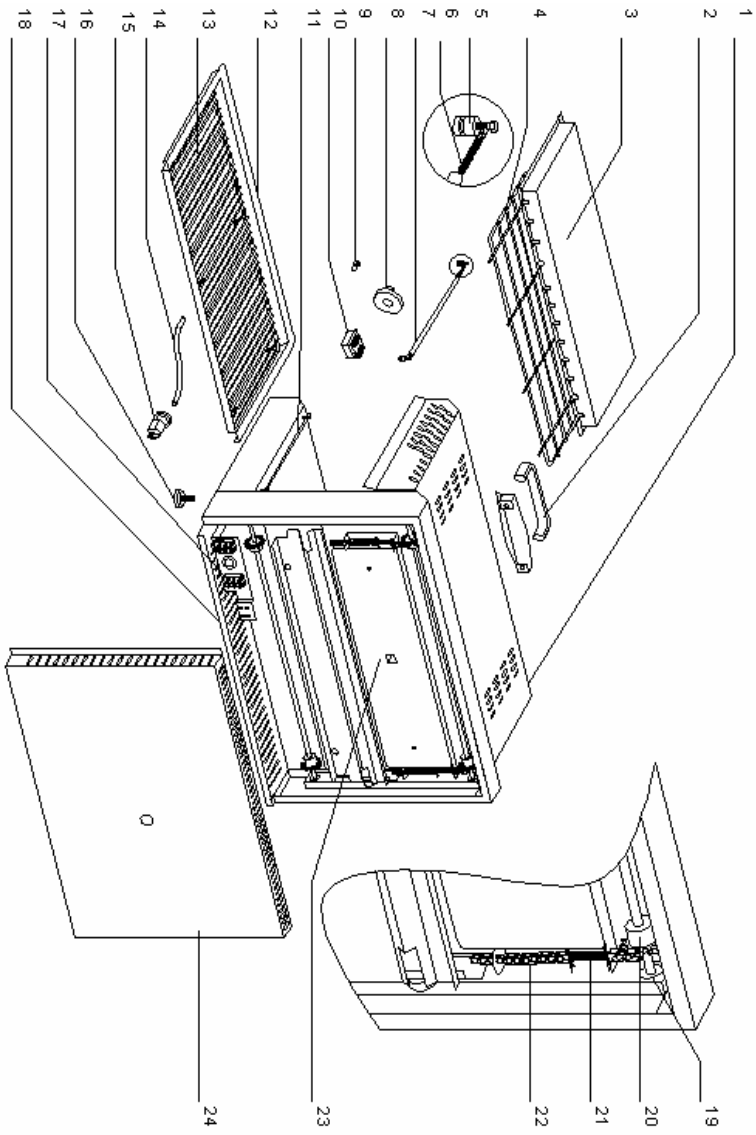

Nomenclature SEM 800 VC
Spare parts SEM 800 VC

Rep	Code	Qty	Pièce	Spare part
1	72076	1	Toit	Roof
2	A15018	1	Poignée	Handle
3	72094	1	Réflecteur	Reflector
4	H01072	1	Glace	Glass
5	D06009	3	Foyer	Ceramic chamber
6	A14078	1	Bouton	Knob
7	A08003	2	Voyant orange	Orange pilot light
8	A01001/1	1	Commutateur	Commutator
9	F02007	2	Glissière plat	Tray slide
10	72065	1	Plat	Tray
11	F01068	1	Grille	Grid
12	C01018	1	Cable	Cord
13	A10032	1	Serre cable	Cord closer
14	A13006	4	Pied	Foot
15	A16010	2	Plaque à borne	Plate for terminal
16	72058	1	Fond socle	Bottom casing
17	B06017	10	Roulement	Ball bearing
18	B01002	4	Pignon	Gear wheel
19	B07004	2	Ressort	Spring
20	B07028	2	Chaîne	Chain
21	72077	1	Contre poids	Against weight
22	72055	1	Fond arrière	Back casing

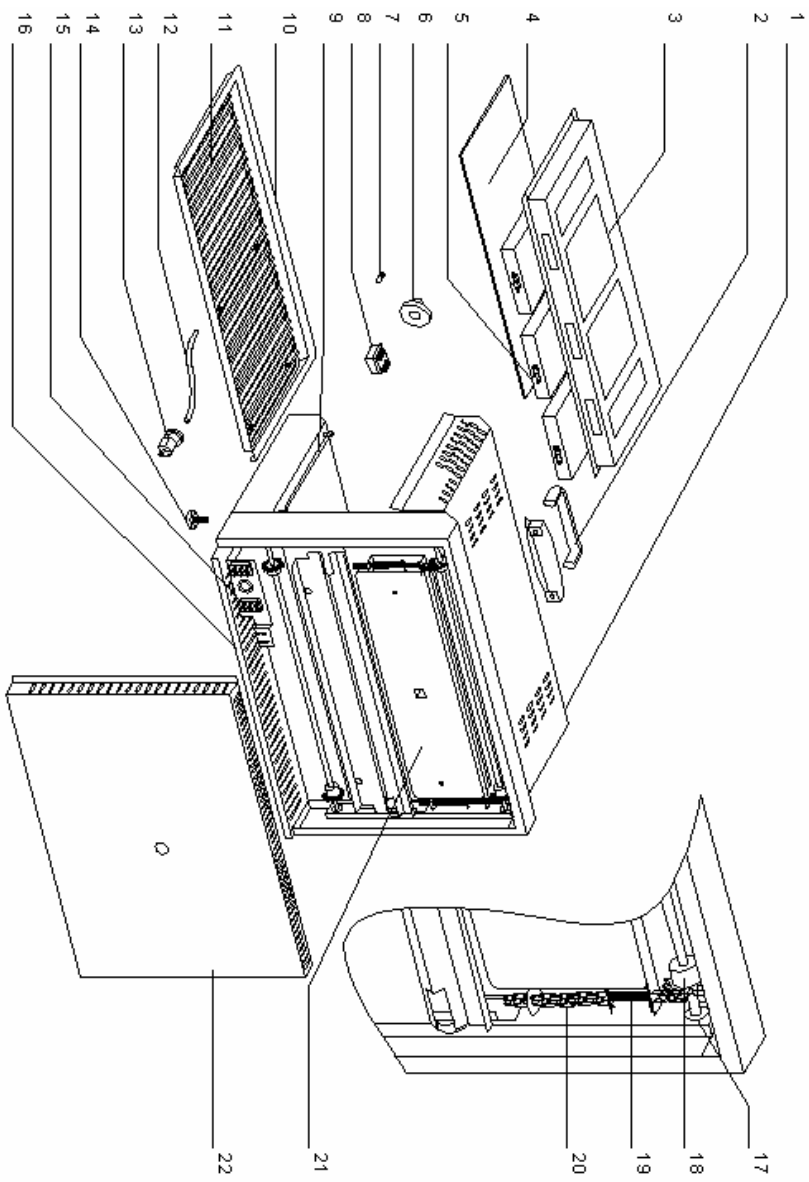

Nomenclature SEF 800 Résistance blindée
Spare parts SEF 800 Armoured heating element

Rep	Code	Qty	Pièce	Spare part
1	72057	1	Réflecteur	Reflector
2	D02162	3	Résistance blindée	Armoured heating element
3	F02007	2	Glissière plat	Tray slide
4	A08003	2	Voyant orange	Orange pilot light
5	A14078	1	Bouton	Knob
6	A01001/1	1	Commutateur	Commutator
7	72052	1	Socle	Base
8	F01068	1	Grille	Grid
9	72065	1	Plat	Tray
10	72056	1	Fond socle	Bottom casing
11	A13006	4	Pied	Foot
12	F01005	1	Grille à poignée	Handle grid
13	72007	2	Support grille	Grid holder
14	72076	1	Toit	Roof
15	72086	1	Arrière	Back
16	72055	1	Fond arrière	Back casing
17	A10032	1	Serre cable	Cord closer
18	C01018	1	Cable	Cord
19	A16010	2	Plaques à borne	Plate for terminal

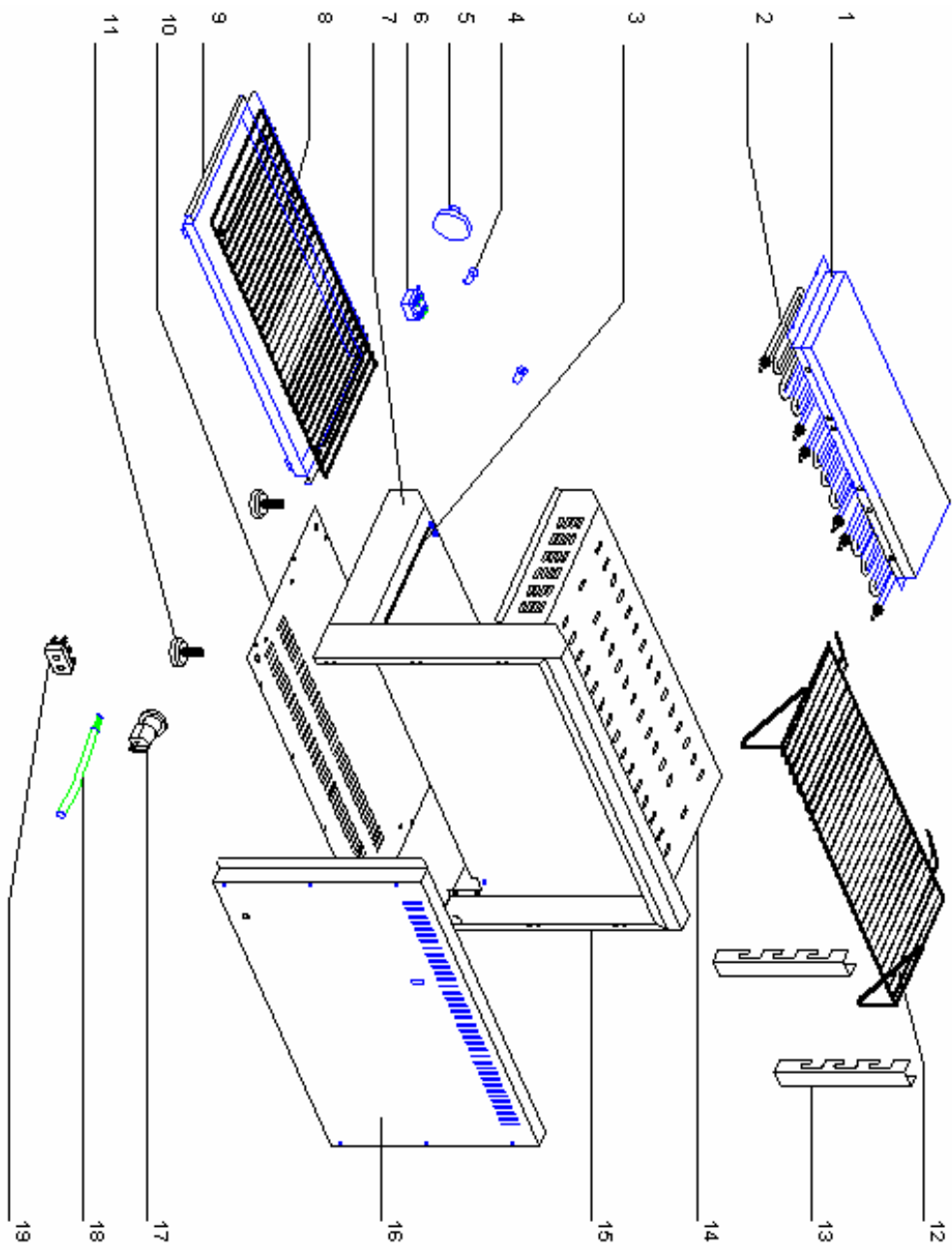

Nomenclature SEF 800 Tube quartz
Spare parts SEF 800 Quartz tube

Rep	Code	Qty	Pièce	Spare part
1	72068SE	1	Réflecteur	Rélector
2	D01045	12	Résistance	heating element
	D04015	12	Tube quartz	Quartz tube
3	A09003COM	24	Steatite complète	Steatite assembly
4	F01067	1	Grille protège tube	Tube protection grid
5	F02007	2	Glissière plat	Tray slide
6	A08003	2	Voyant orange	Orange pilot light
7	A14078	1	Bouton	Knob
8	A01001/1	1	Commutateur	Commutator
9	72052	1	Socle	Base
10	F01068	1	Grille	Grid
11	72065	1	Plat	Tray
12	72056	1	Fond socle	Bottom casing
13	A13006	4	Pied	Foot
14	F01005	1	Grille à poignée	Handle grid
15	72007	2	Support grille	Grid holder
16	72076	1	Toit	Roof
17	72086	1	Arrière	Back
18	72055	1	Fond arrière	Back casing
19	A10032	1	Serre câble	Cord closer
20	C01018	1	Cable	Cord
21	A16010	2	Plaque à borne	Plate for terminal

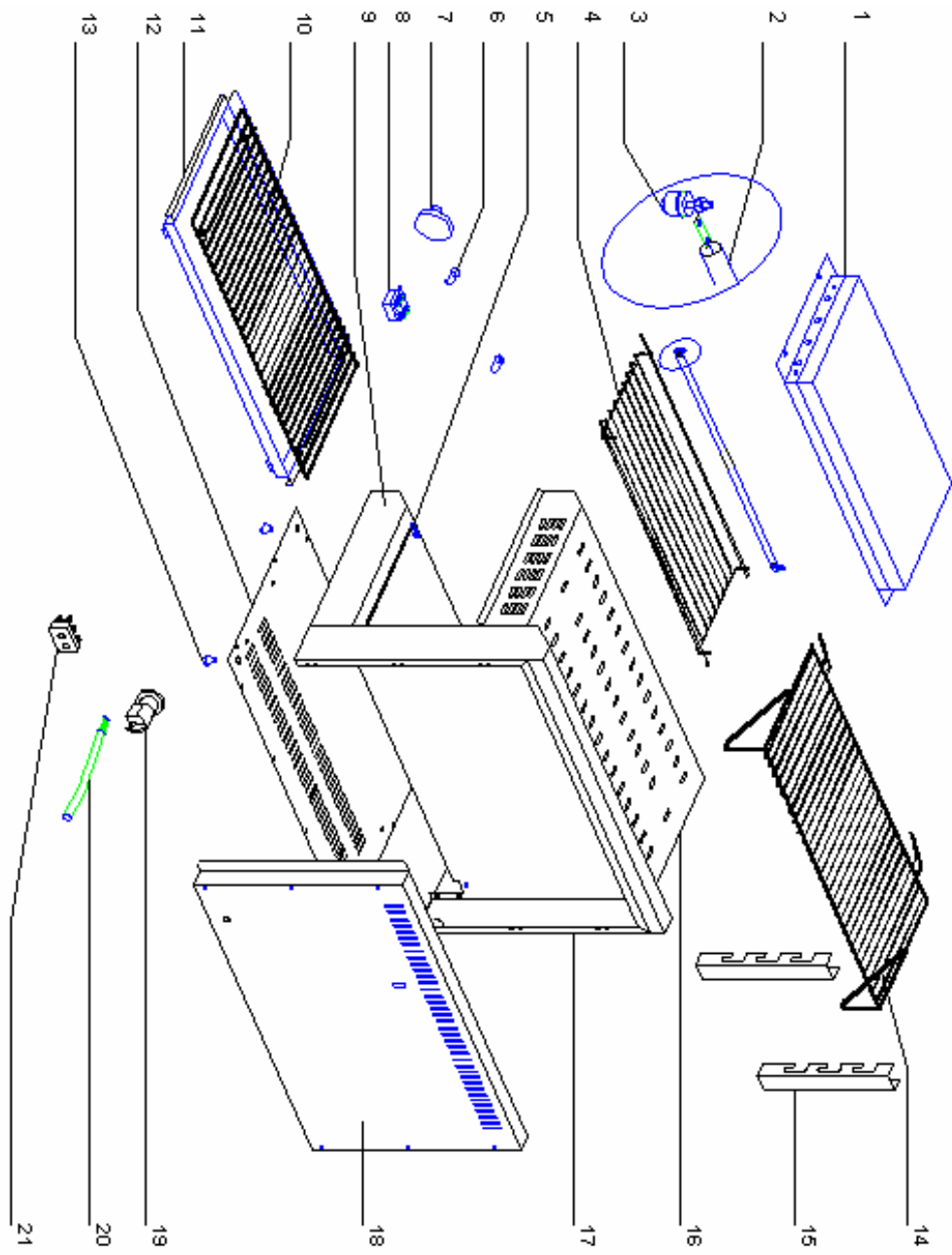

G03227