

# 卡丽 KARAT

## 安装说明书 INSTALLATION INSTRUCTIONS

AGAVE  
TALL LAVATORY FAUCET  
面盆龙头  
35367VN-CP

### BEFORE YOU BEGIN

Please read these instruction carefully familiarize yourself with the required tools, materials, and installation sequences. Follow the sections that pertain to your particular installation. This will help you avoid costly mistakes. In addition to proper installation, read all operating and safety instructions.

All information in these instructions is based upon the latest product information available at the time of publication. Karat reserves the right to make changes in product characteristics, packaging, or availability at any time without notice.

These instructions contain important care, cleaning, and warranty information, please leave instructions for the consumer

#### NOTES:

Flush the water supply pipes thoroughly to remove debris.

### 安装之前

请仔细阅读说明书，熟悉所需工具、材料和安装顺序，参照相关章节完成您所需的安装，以避免昂贵的损失，除了正确的安装外，请详阅所有的操作和安全说明。

本说明书所含的一切资料均以印刷时所有的最新产品为准，卡丽公司保留权利随时更改产品特性、包装或供应情况，恕不另行通知。

本说明书也包含了有关保养、清洁及产品担保等重要信息，请交予用户保存。

#### 注意事项：

一定要先彻底冲洗供水管以及清除管道中的杂质。

### ROUGHING-IN

Unit:mm

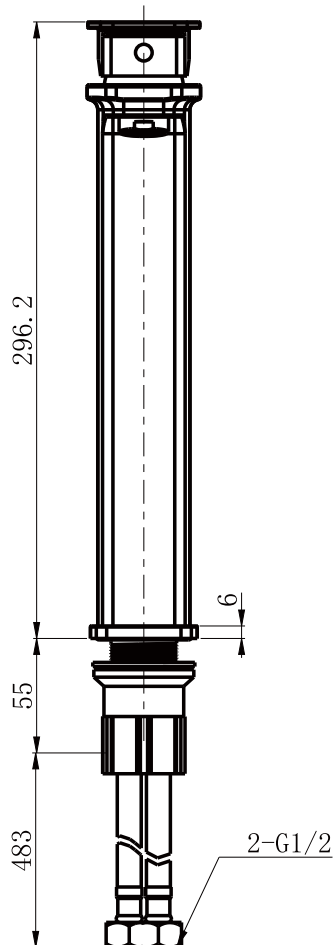

### 尺寸图

单位:毫米

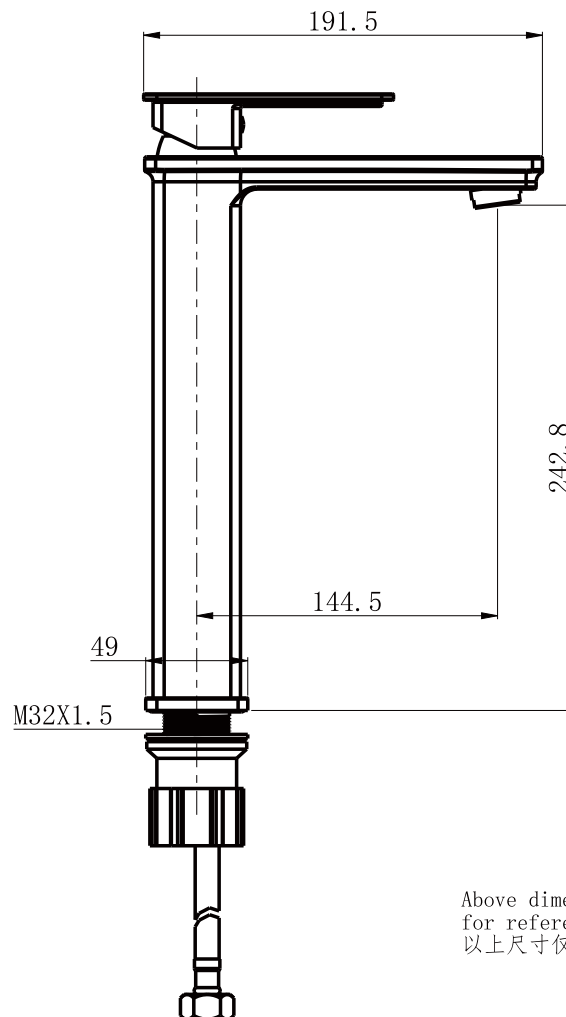

Above dimensions are for reference only.  
以上尺寸仅供参考。

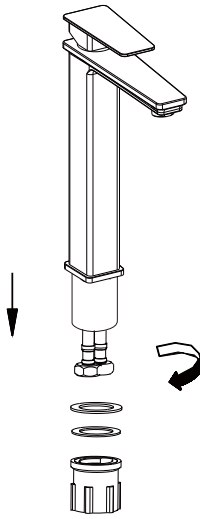

1. 拧下黑筒，取下白色塑料垫片和黑色橡胶垫

Unscrew the black barrel and remove the gasket and rubber pad.

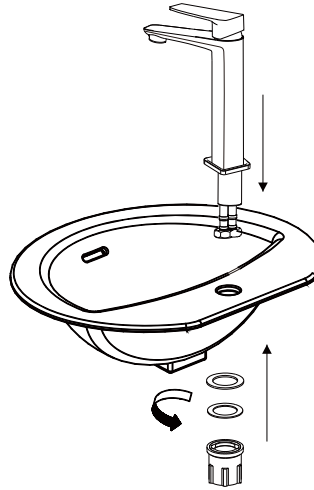

2. 将龙头插入面盆安装孔内，并锁紧龙头

Insert the faucet into the basin mounting hole and lock the faucet in place.

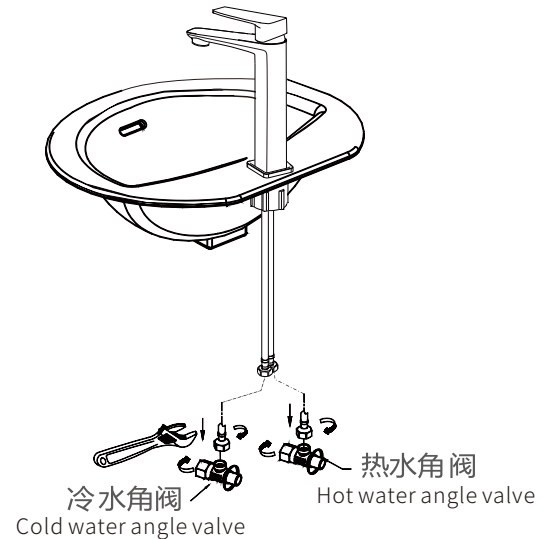

3. 关闭冷热水角阀，将龙头冷热水进水软管分别接入角阀  
\*红色标识软管接热水角阀

Hot and cold water inlet hoses are connected to the angle valves.

INSTALLATION CHECKOUT

安装后检查

Ensure that all coupling nuts are tight. Ensure that the lever handle is in the close position.

Turn on the main water supply, and check for leaks. Repair as needed.

Remove the aerator assembly and hand spray. Run hot and cold water through the faucet for about a minute to remove any debris. Check for leaks. Remove any debris from the aerator assembly. Shut the faucet off, and reinstall the aerator assembly and hand spray.

确保所有衔接螺母都已拧紧，确保手柄处在关闭的位置，开启主水源，检查是否有漏水，如有请重新拧紧。

取下起泡器组件和花洒。把冷热水都打开，让水流出一分钟以清除杂质，检查漏水。清洗起泡器并关闭龙头，装回起泡器组件和花洒。

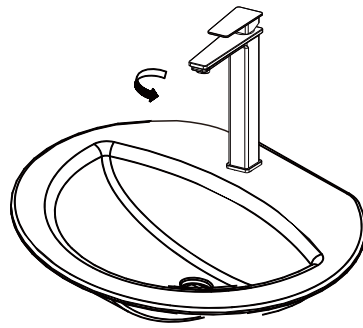
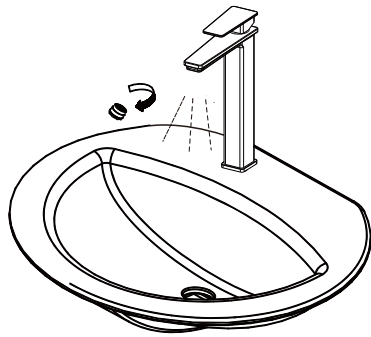

## HOW TO USE

1. Rotate the left handle to control the stream of hot water and rotate the right handle to control the stream of cold water .
2. Rotate the left handle counterclock to turn on the hot water and vice versa. Rotate the left handle anticlockwise wise to turn on the cold water and vice versa.

**Note:** Do not use the faucet under high temperature since some of its inner components contain temperature-unstable substances, such as silicone sealant. Do not use the faucet for a long time if the water temperature is below 90°C.

## 使用方法

1. 左把手控制热水，右把手控制冷水。
2. 逆时针旋转左把手为开启热水，反之为关水。顺时针旋转右把手为开启冷水，反之为关水。

**注意：**龙头内部结构含有硅胶等不耐高温成份，请勿在高温环境下使用，请勿在超过90℃的水温下长时间使用。

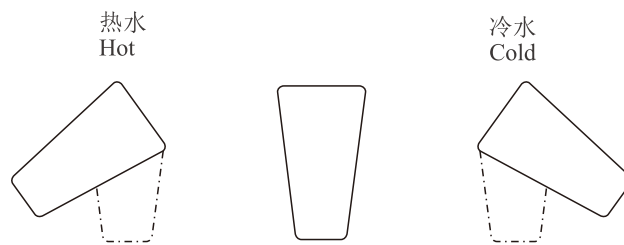

## CLEANING INSTRUCTIONS

All finishes : clean the finish with a mild soap and warm water. wipe entire surface completely dry with a clean soft cloth. Many cleaners may contain chemicals , such as ammonia chlorine, toilet cleaner etc., Which could adversely affect the finish and are not recommended for cleaning.

Don't use abrasive cleaner or solvents on karat faucets and fitting.

## 清理说明

适用于所有加工处理过的表面：  
以中性肥皂水清洗镀层表面，再以干净的软布彻底擦干整个表面。许多清洁剂，比如氨水、去污粉及洁厕灵等，会对电镀表面造成伤害，切勿使用。

有腐蚀性的清洁剂或溶剂不可使用于卡丽的水龙头及其附件上。

KOHLER ASIA PACIFIC LIMITED  
Address: 14/F, No.88 Gloucester Road,  
Wanchai, Hong Kong

# 卡丽 KARAT®

## 维修零件图 SERVICE PARTS PAGE

AGAVE  
TALL LAVATORY FAUCET  
面盆龙头  
35367VN-CP

