

## BLASI K42 four - leaf revolving door



### **SYSTEM:**

Four – leaf automatic or manual revolving door which is available in various design options.

Executions with night shutters in manual or automatic version, with electric or mechanical locks, push bars in different variations or specific glass requirements that can be realized with BLASI.

Every 4-leaf automatic revolving door turns in anticlockwise direction and is always equipped with the latest safety features to provide safe and reliable function.

The canopy structure is made of a solid and strong steel structure including thermal insulation and clad in aluminum plates along the pelmet and closed with a standard dust cover. The ceiling underside is closed with segmented aluminum plates that provide a solid and perfect flush view.

Highly engineered and reliable drive components ensure a smooth and safe operation at all times.

- Four – leaf revolving doors provide comfort ideal for office buildings, airports, train-stations, hospitals, shopping centers, hotels and many more
- Quarter point position provides high seal and reduces wind draft into building
- Climate control (temperature, air condition wind-drafts) which reduces costs
- Flexible design options by BLASI provide totally customized solutions for any entrance
- Full glass option available for incredible transparency mainly for glass facades

# BLASI K42 four - leaf revolving door

INSIDE Diameter "U" (drum wall)		
Minimum diameter	1600 mm	approx. 5' - 3"
Maximum diameter	7000 mm	approx. 23'
OUTSIDE Diameter "Q" (canopy pelmet)		
Diameter inside + 58mm (≈ 2 - 2/8") = outside diameter		

Passage Height "G"		
Minimal	2100 mm	approx. 6'- 11"
Maximal	3000 mm	approx. 9'- 10"

Entrance Opening "A" (between cylinder walls)	
Please calculate with underneath formula: Diameter "Q" x 0,707 - 130 = passage width in mm	

Passage Height "G"		
Minimal	2100 mm	approx. 6'- 11"
Maximal	3000 mm	approx. 9'- 10"

Canopy Height "I"			
Minimal	250 mm	≈10"	< Ø 3500 mm
Minimal	350 mm	≈10"	> Ø 3500 mm
Minimal	500 mm	approx. 20" <u>with air curtain</u>	

Throughput Capacity (based on bi-directional use)			
2500 mm	3000 mm	3500 mm	4000 mm
≈ 8' - 2"	≈ 10"	≈ 11" - 6"	≈ 13' - 2"
2400 p/h	2450 p/h	3220 p/h	3300 p/h
Above capacity is based on theoretical calculation with maximum occupancy of persons per segment per hour in both directions (without engagement).			

Door Speed in U/min (rpm's) *	
For diameter < 2500 mm	Adjustable, max. 5,8 U/min
For diameter < 3500 mm	Adjustable, max. 4,2 U/min
For diameter < 4800 mm	Adjustable, max. 3,2 U/min

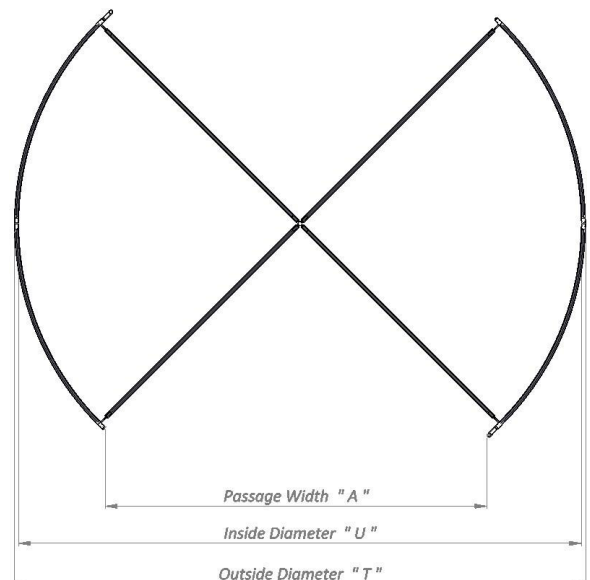
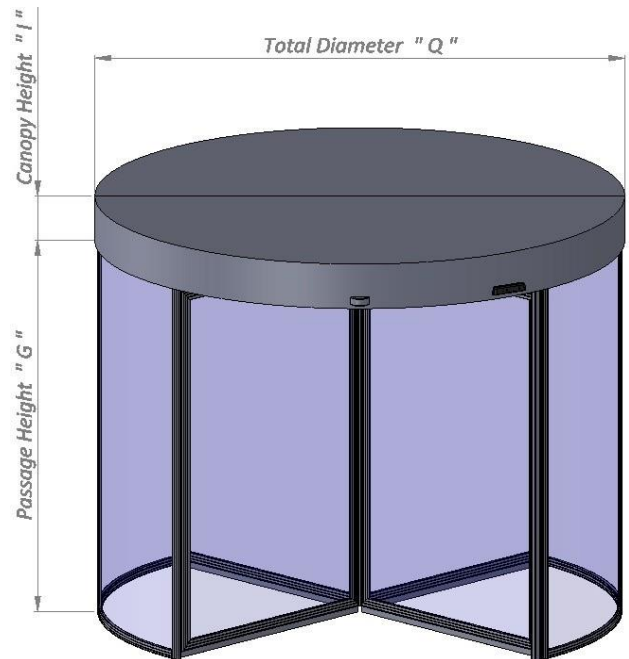

\* Please note that the speed needs to be adjusted in accordance to your local codes & requirements

# BLASI K42 four - leaf revolving door

**SAFETY FEATURES:**

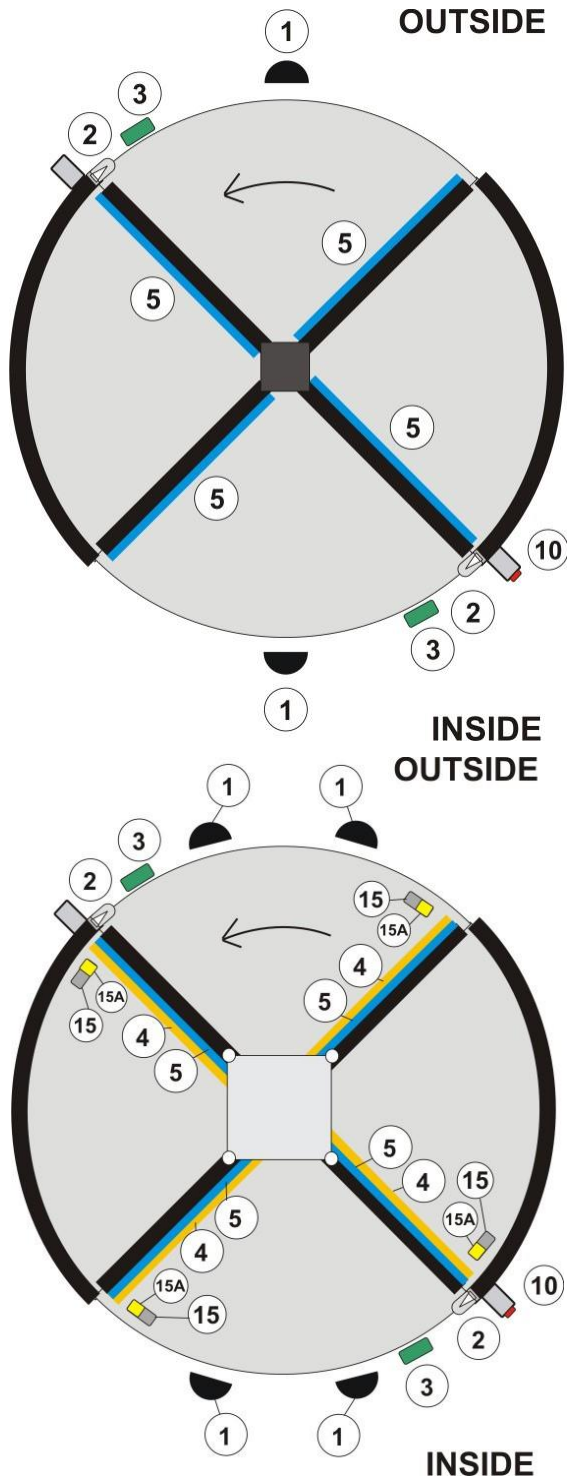

- 1) 2x infrared detector type: **F**  
4x when entrance opening is > 2000mm  
or  
2x motion detector type **RAD290**  
4x when entrance opening is > 2000mm
- 2) 2x electro safety strips drum edge "77mm"
- 3) 2x vertical sensors type **I-ON-C**  
clear passage height < 3000mm
- 4) 4x sensors strips type: **TOPSAFE (TS)**  
mounted at top turnstile door leaf to slow down door  
mounting height must be < 3000mm  
**OPTION** for doors < 3000 mm (9' - 10")  
**STANDARD** for doors > 3000 mm (9' - 10")
- 5) 4x electro safety strips heel protection "45mm"
- 15) 4x presence detector vertically in front of leading door leaf  
type: **TOPSAFE-TS**
- 15a) 4x forward sensor type: **W-LP** if passage height > 3000mm
- 10) 1x emergency stop switch (behind glass) mounted in the  
vertical support tube 1x inside mounting height 1200mm
  - operating switch with standard key, mounting height 1200mm (OFF - AUTO - CONTINUOUS - HAND)
  - 4x label (decal mandatory signs) "mother and child / dog"
  - 2x slow down push button mounting height 800mm  
**(OPTIONAL 1x outside & 1x inside)**
  - 1x emergency operating key switch mounted in the tube  
**(OPTIONAL 1x inside)**
  - 1x IBS - "digital error and program display system  
**(OPTIONAL 1x inside)**
  - electromechanical bistable locking 24V DC  
**(OPTIONAL 1x inside the canopy)**

	key operating switch inside as standard
	emergency stop switch inside as standard
	slow down push button inside and outside <b>optionally</b>
	emergency operating key switch inside <b>optionally</b>

NOTE: Above diagrams show only basic location of safety features without obligation.

# BLASI K42 four - leaf revolving door

**DESIGN FEATURES:**

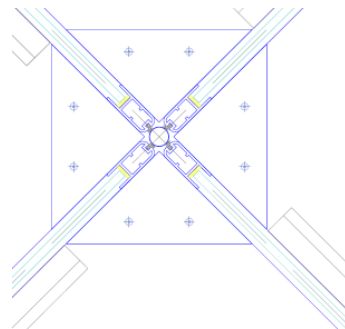
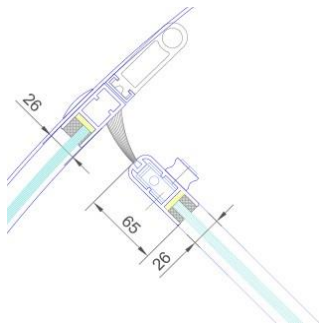

- basic design with slim 26mm x 26mm profiles for automatic and manual revolving doors
- robust and self supporting steel or aluminium structure
- natural horse-hair brush seals
- wet glazing (silicone) that provides high durability

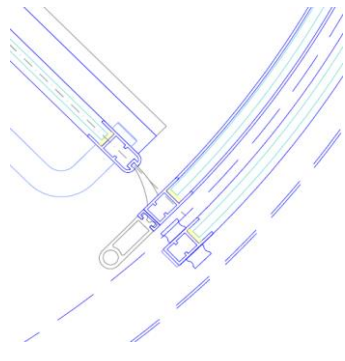
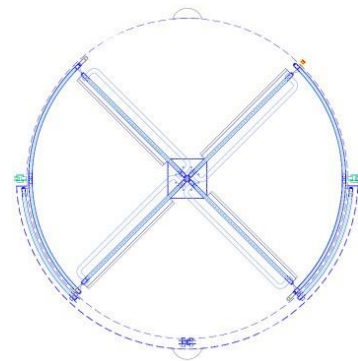

- night-shutter available in manual or automatic version
- outside or inside of cylinder walls (drum) possible
- in glass or panel construction
- with full or half profile cylinder lock available
- keeps entrance clean at night and provides higher security

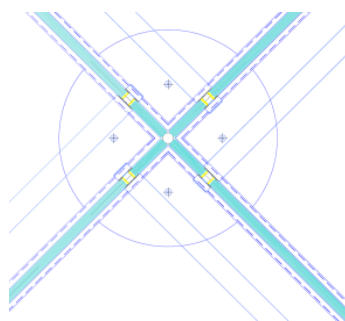
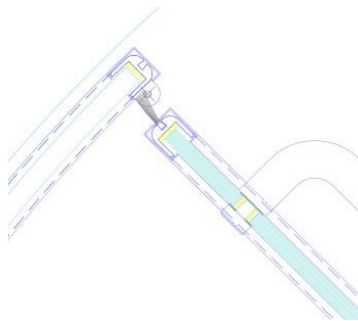

- vitro design for manual revolving doors
- super slim Blasi profiles with 26mm x 27mm
- horizontal stainless steel handles for stability
- middle of turnstile without any profiles

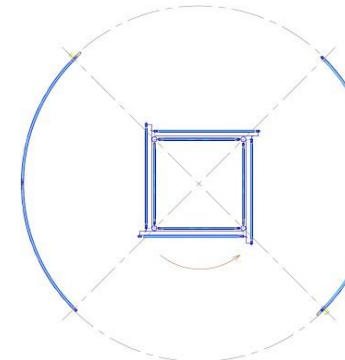
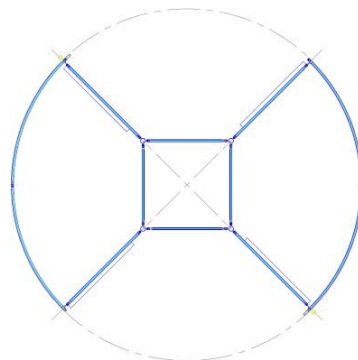

- middle show-case (display) for larger revolving doors with lockable accessible leaf
- straight, concave- or convex-curved show case executions possible
- allows the handling of large goods through the door and supports escape routes as all leaves are collapsible

## BLASI K42 four - leaf revolving door

### BASIC EQUIPMENT:

The door is supplied including the following basic parts and features:

1 no. Operating switch with following modes:

(OFF– Automatic – Continuous – Hand)

1 no. Emergency Stop Switch

### **OPTIONAL:**

1 no. Digital status and error display

2 no. Slow down push buttons

Including all necessary safety features as required by latest standards (refer to page 3).

### SURFACE:

The surface can be provided in any standard RAL powder coating or standard anodizing where BLASI provides and uses the highest quality. Stainless steel clad surface in quality 304 or 316, bronze or brass are also possible on a totally bespoke execution.

### BASIC OPTIONS:

- Floor Ring (Sub-structure) in stainless steel to receive matting for 17, 22 or 25mm
- PURUS floor-mat by BLASI with felt strips in anthracite or other colors, height 22mm
- 4 pc. LED spot lights integrated in the rotation ceiling ; 12 V DC and 1,2 Watt
- 4 pc. Halogen spot lights integrated in the rotation ceiling ; 12 V DC and 20 Watt
- Horizontal or vertical push bars in different design options available; standard push bars in stainless steel 304 diameter 30mm
- Watertight roof at outside (180°) including two water spouts to drain the water
- Dust roof 180° or 360° in aluminum raw, RAL, anodized, stainless steel etc.....
- Air curtain (heater) including air duct and air outtake for electrical or warm water supplies
- Monitoring contacts for door position and lock status (low voltage, NO)

### GLAZING:

The drum walls is made of special slim BLASI aluminum extrusions with a size of only 65 x 26mm (height x width) and glazed with clear 10,76mm curved laminated safety and 8mm clear straight single toughened safety glass. Typically is a single sheet tempered safety glass with 10mm used.

### DESIGN OPTIONS:

- Low Iron Glass (White-Glass); tinted glass and Special Glasses on request
- Drum walls solid panel construction, framed or flush instead drum walls with glass
- Night shutter (2x 45° leaves) outside or inside available in various options
- Mid-Rails (muntin) at drum walls or rotating centerpiece, impact protection from trolleys
- Individual design executions possible on request possible such as signage, special illumination etc.
- 2 manually foldable door leaves for transportation purposes (no break-out) that will fold parallel in front the other two rigid leaves
- Middle Show-Case (display) in straight, concave or convex design that starts from diameters with 3200 mm (approx. 10'), all four door leaves will be manually collapsible and during normal operation hold with electromagnets
- VITRO – Design (Full Glass Execution) available for up to 3000mm in diameter (9' - 9'") with a maximum total height of 4000mm (13'), this design requires horizontal push bars to stabilize the turnstile
- Column – Drive that will allow to build the door around a structural existing steel or concrete column (pillar), provides solutions even for narrow spaces where revolvers can be used
- Individual design options always possible; please contact your local BLASI sales partner

## BLASI K42 four - leaf revolving door

### **TECHNICAL DATA:**

Power supply	230V AC or 120 V AC, 50 - 60Hz
Power connection	single phase alternative current, fused 16 Ampere
Power consumption	250 Watt (Ø 2000mm); 1600 Watt (Ø 6000mm)
Control Unit	24V DC (short-circuit-proof)
Motor Current	48V DC (pulsed)

- all cables and conduits has to be supplied by others (as per wiring diagram by Blasi)
- optionally monitoring contacts for status of lock and door position (potential free, NO)
- optionally monitoring contacts for door interruptions and status (potential free, NO)

### **ENVIRONMENTAL CONDITIONS:**

Temperature Range	-15°C (45°F) up to + 50°C (105°F)
Humidity Range	up to 85% relative humidity
Case Protection	IP 20

### **CONTACT:**

BLASI GmbH  
Automatic Door Systems  
Carl-Benz-Str. 5 – 15  
77972 Mahlberg / Germany

P.: +49 7822 893-160  
F.: +49 7822 893-169

Email: [sales@blasi.info](mailto:sales@blasi.info)  
Web: [www.blasi.info](http://www.blasi.info)



NOTE: Blasi reserves the right for technical or content alterations without pre-notification at any time.