



PONYZO

- ĐỘ TUỔI: 1-6 TUỔI
- TỐI ĐA TẢI: <50kg
- THỜI GIAN LẮP RÁP: 30 phút
- CHIỀU CAO GHẾ NGỒI: 20-35cm
- TRỌNG LƯỢNG: 2-3 kg



Scan Me



PNZ-1507

XE LẮP RÁP

SÁNG TẠO

Cho Bé vận động thông minh

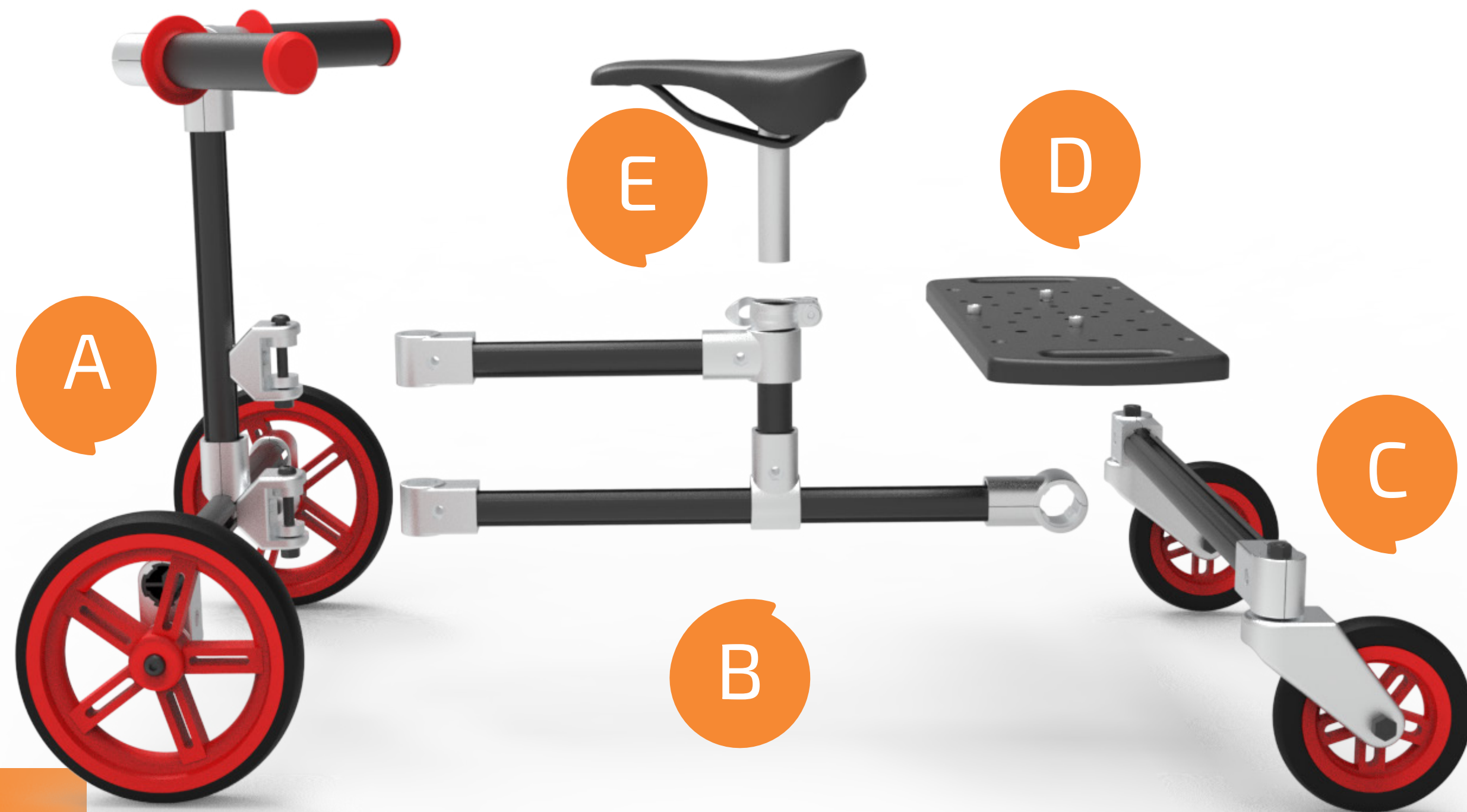

LẮP RÁP TỪ ĐẦU ĐẾN CUỐI

- Tự mình lắp ráp hoặc 1 nhóm 2 bạn.
- Khi lắp ráp nhóm thì 1 bạn sắp xếp và chuẩn bị các linh kiện, hỗ trợ cho bạn còn lại lắp ráp.
- Có thể thay đổi vai trò của nhau để thêm vui



--- A, B, C, D, E

CHIA NHỎ CÁC BỘ PHẬN LẮP RÁP

- Khi chúng ta có 2 người hoặc nhiều hơn.
- Chúng ta chia ra lắp ráp các bộ phận riêng biệt.
- Sau đó kết nối các bộ phận lại để hoàn thành sản phẩm.



--- A, B

--- C, D



























E

TRANG

< 2 >



BẢNG PHỤ KIỆN CHI TIẾT

STT	PARTNAME	QTY		STT	PARTNAME	QTY	
1	Khớp nối P1	2		15	Ống D-400	1	
2	Khớp nối P2	2		16	Ống D-350		
3	Khớp nối P3	4		17	Ống D-300	2	
4	Khớp nối P3A	1		18	Ống D-250	1	
5	Khớp nối P3B	2		19	Ống D-200	1	
6	Khớp nối P4	2		20	Ống D-150	1	
7	Khớp nối P5			21	Ống D-100		
8	Khớp nối P6			22	Ống D-50	1	
9	Khớp nối P7			23	T1-Tay lái	2	
10	Khớp nối P8			24	Y-Yên xe	1	
11	Khớp nối P13	2		25	T2-Cọc yên	1	
12	W3-Bánh xe Lắc	2		26	S1-Lót chân	1	
13	W1-Bánh xe 120			27	Hộp linh kiện	1	
14	W2-Bánh xe 200	2					

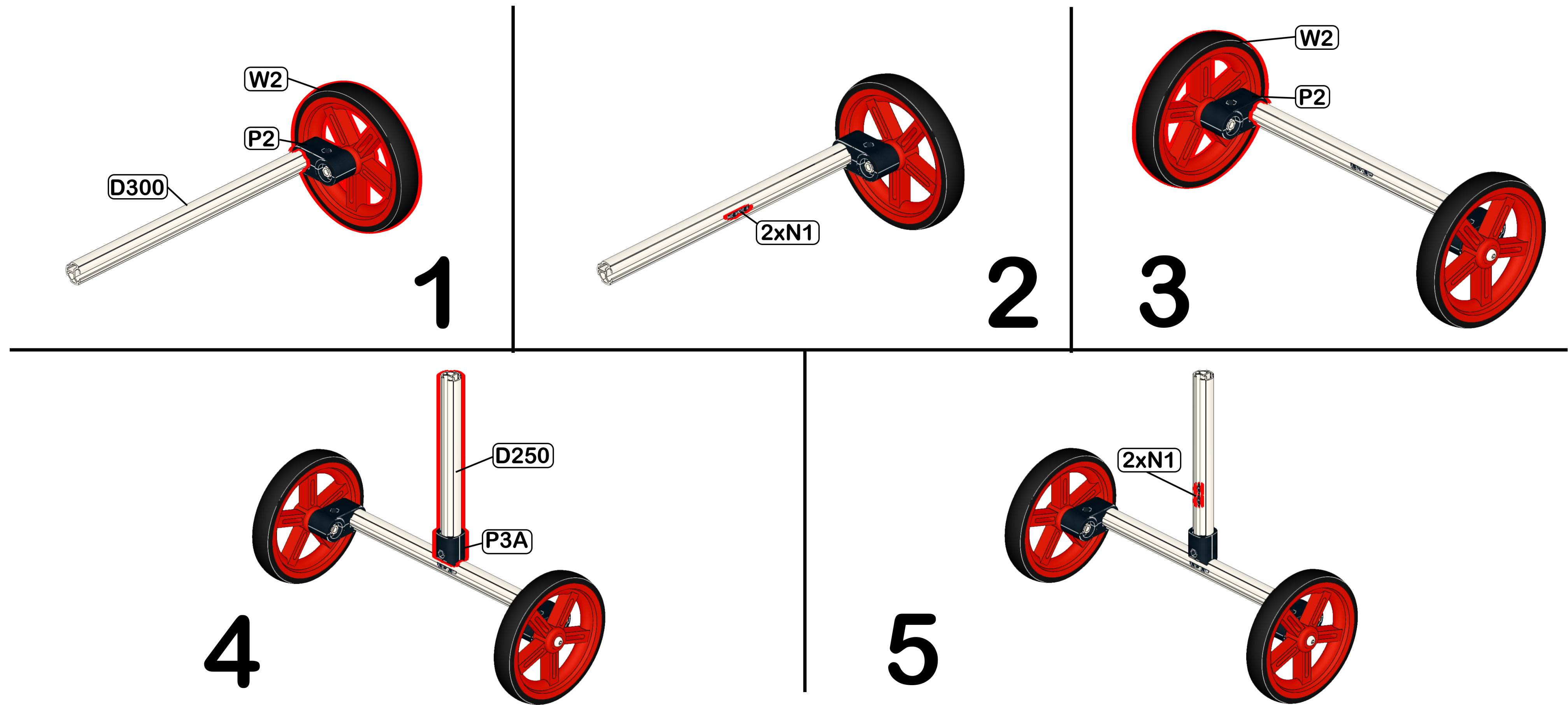

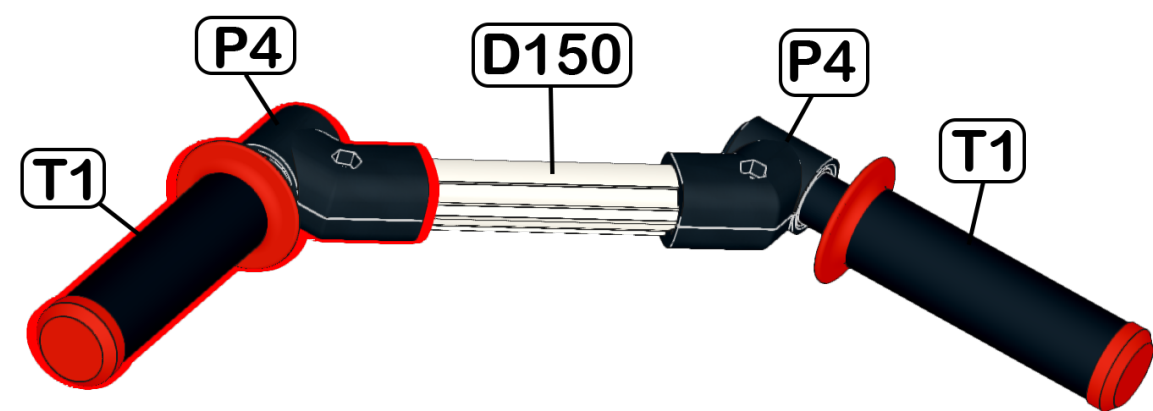

6

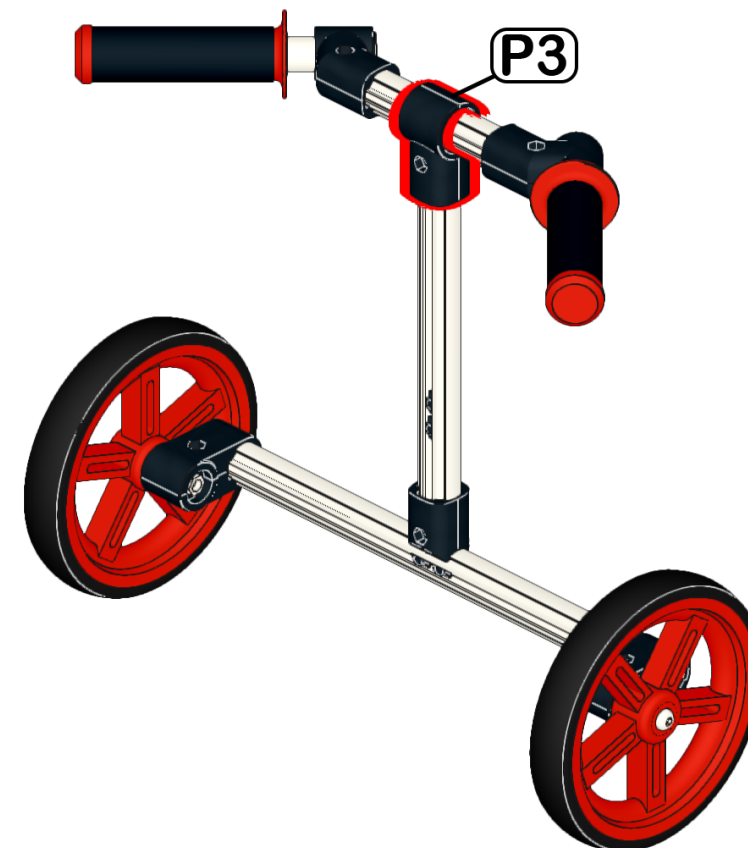

7

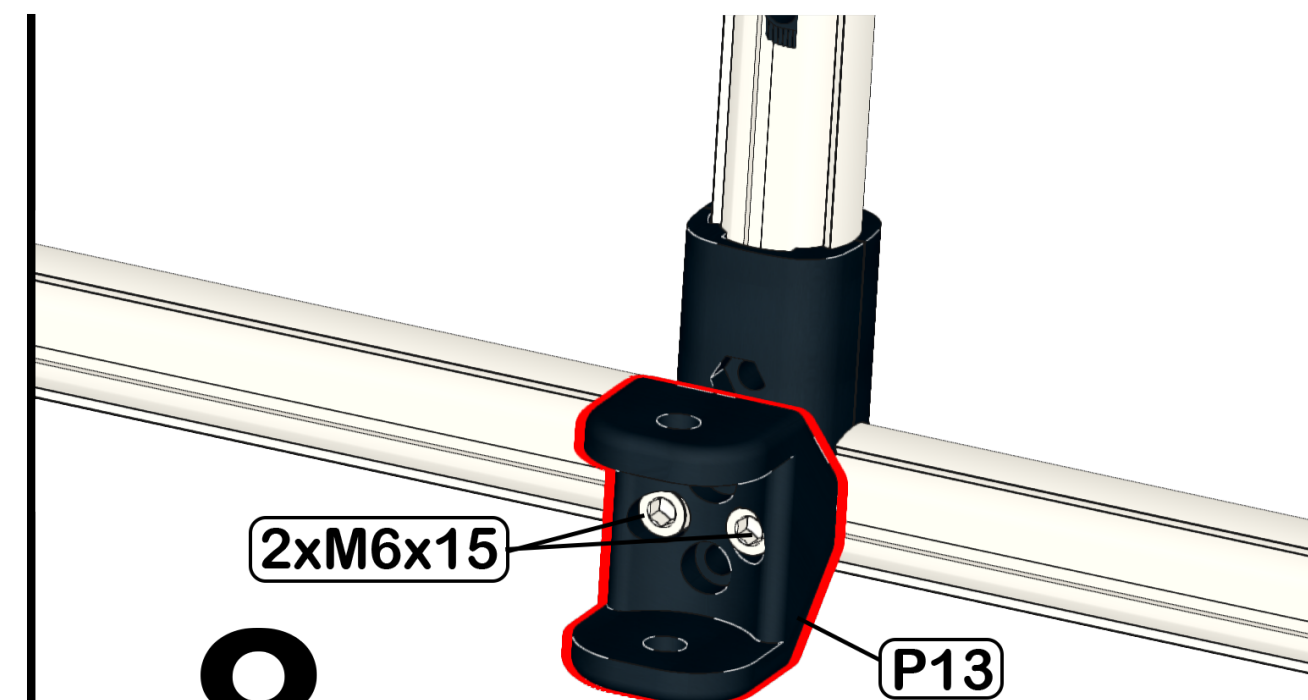

8

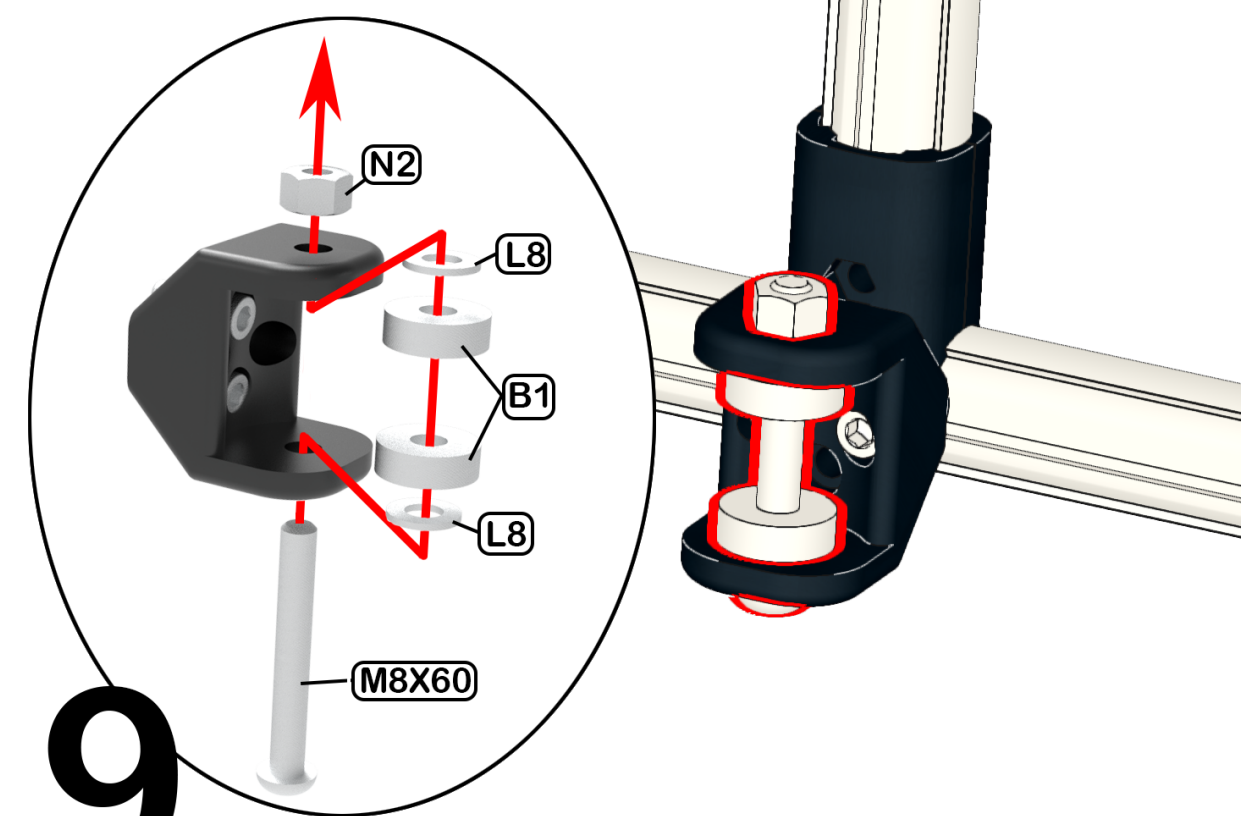

9

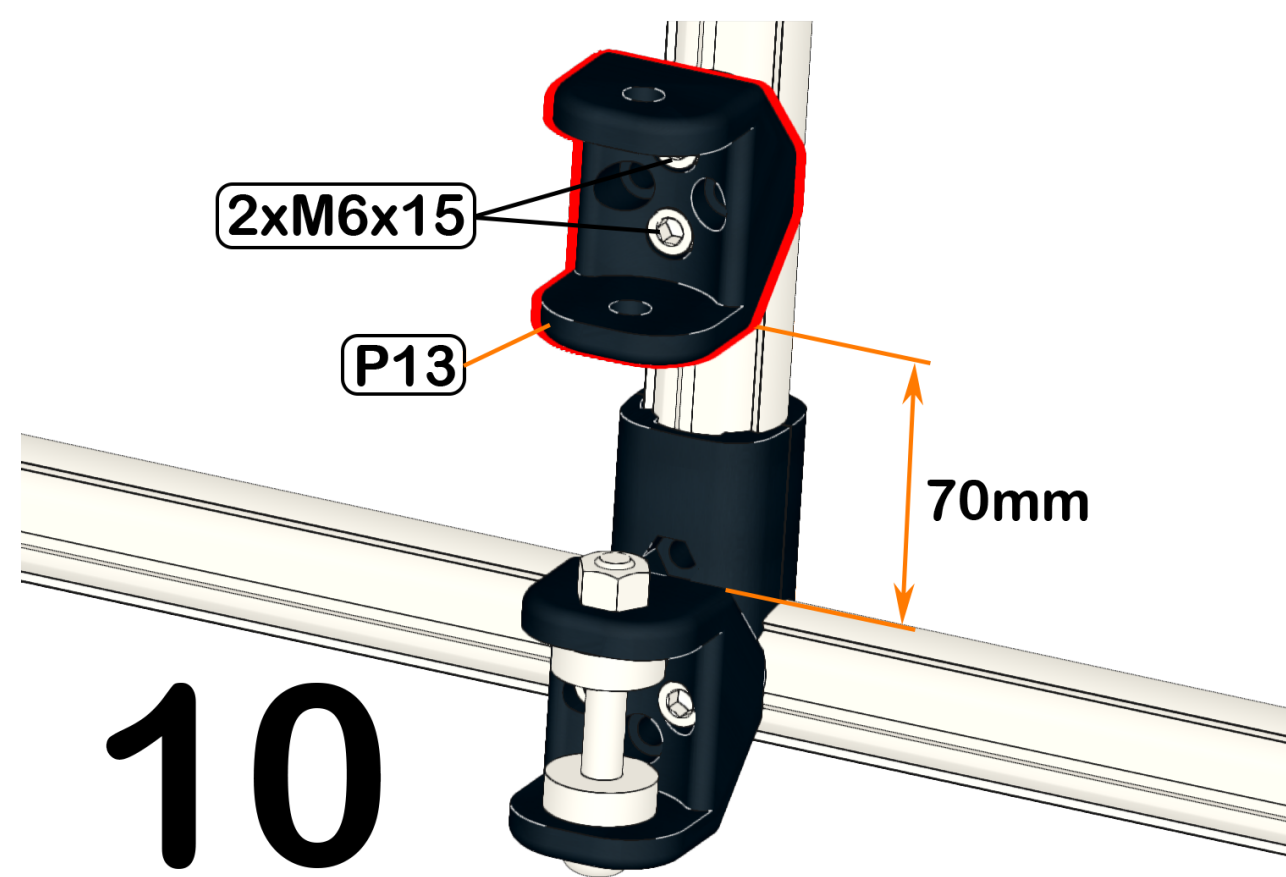

10

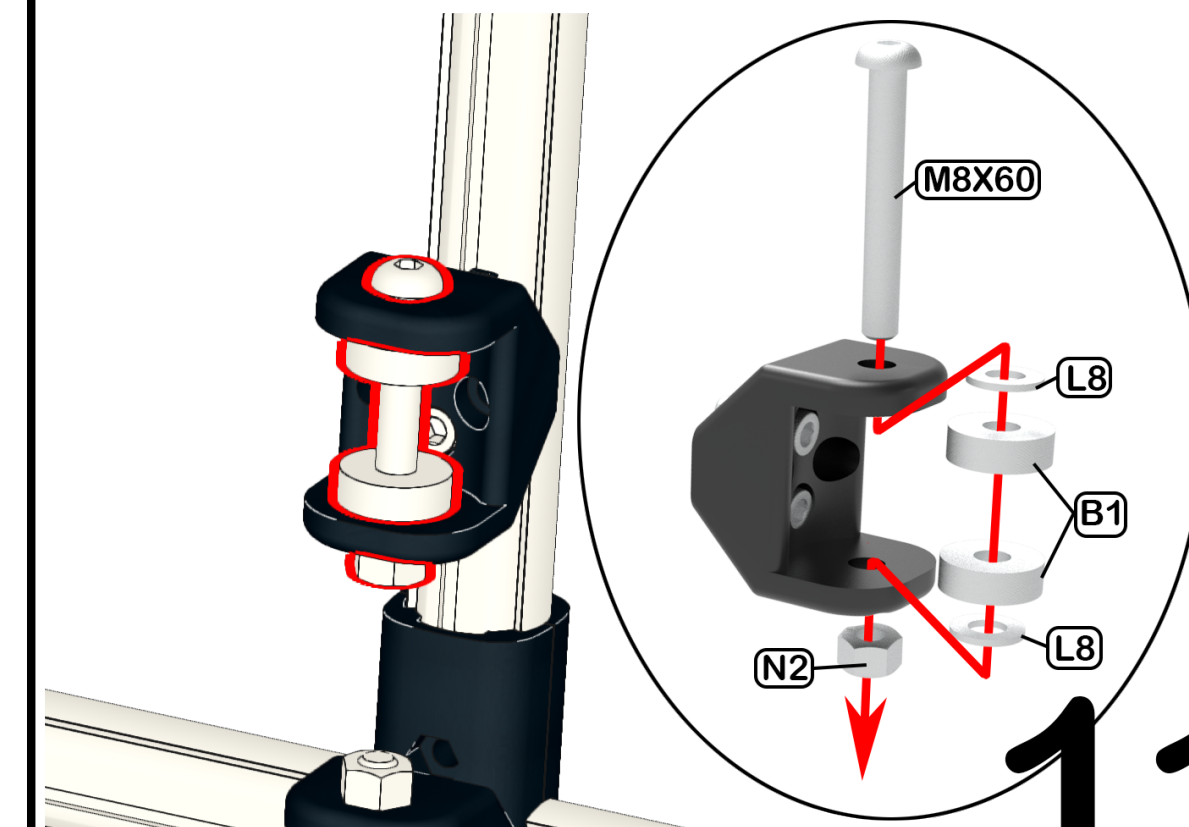

11

