

Neodymium Magnet Die-cast Chassis Driver



Specifications

General Specifications

Nominal diameter.....	381 mm/15 in
Power rating.....	600 W(AES)
Nominal impedance.....	8Ω
Sensitivity.....	97 dB
Frequency range.....	55-20000 Hz
Chassis type.....	Cast aluminum
Magnet type.....	Neodymium
Magnet weight.....	0.58 kg/20.5 oz
Voice coil diameter.....	82.5 mm/3.25 in
Coil material.....	CCA-W
Former material.....	Glass fiber
Cone material.....	Paper
Surround material.....	Cloth
Suspension.....	Single
X-max.....	4.8 mm/0.19 in
Gap depth.....	10 mm/0.39 in
Voice coil winding width.....	19.6 mm/0.77 in
Net Weight.....	5.8 kg/12.8 lb
Packing Dimension WxDxH.....	430 x 430 x 250 mm
Shipping Weight.....	7.2 kg/15.9 lb

Small Signal Parameters

Re.....	5.5Ω
Fs.....	50 Hz
Mms.....	91.46 g/3.23 oz
Mmd.....	77.08 g/2.72 oz
Qms.....	5.84
Qes.....	0.43
Qts.....	0.40
Vas.....	116.02 lt/4.1 ft³
Bl.....	19.21 Tm
Cms.....	1.1e-04 m/N
Rms.....	4.83 Ns/m
Le (at 1kHz).....	0.46 mH
Sd.....	855 cm²

Features

- Coaxial Two Way Design
- 3.25" Woofer Voice Coil
- Medium Format Titanium Compression Driver
- 2400 Watts Peak Woofer Power Handling
- Integrated Demodulation Rings
- Neodymium Magnetics
- Precision Circular Inside/Outside Wire Geometry
- Die Cast Aluminum Chassis

Applications

The P Audio SN15-500CX is a high performance coaxial transducer. The SN15-500CX is an upgraded design that features many of P Audio's new technologies and performance upgrades. The low frequency section utilizes a large diameter voice coil design while the high frequency section employs a medium format titanium diaphragm assembly. The 15 inch (381mm) diameter piston will produce extremely high sound pressure levels at both low and mid band frequencies and is ideal for high level response in both live sound and recorded music venues. The transducer uses very high energy neodymium magnetics to achieve a very high acoustic output to weight ratio. The SN15-500CX has been optimized for use in two way or three way sound reinforcement systems and has an operating range of 55Hz to 20000Hz.

The SN15-500CX features a large 3.25 inch (82.5mm) diameter voice coil that provides an AES rated 600 watts of continuous power handling and a full 2400 watts of peak rated power handling when sufficient amplifier headroom is available. The SN15-500CX employs P Audio's under damper venting to control turbulent air flow.

The voice coil design is a bobbin wound geometry with P Audio's inside/outside wire technology to improve conversion efficiency and provide a large cross-sectional area for superior cooling.

The high frequency section is a close spaced titanium diaphragm assembly. The diaphragm is a 2.5 inch (63.5mm) diaphragm that provides excellent high frequency response and superior power handling and durability. The horn loading is provided via a thru pole piece configuration. The overall high frequency design provides very high sensitivity.

The transducer chassis is a die cast aluminum design that insures a very high degree of structural integrity.

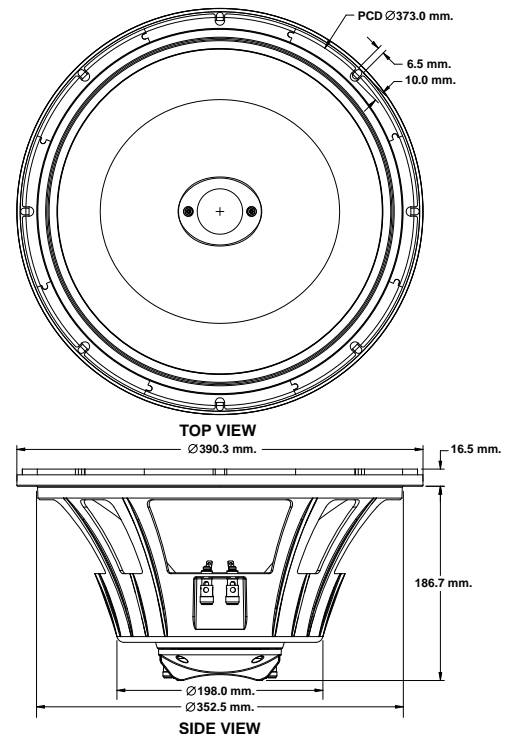

Frequency Response and Impedance Curves

