

Neodymium Magnet Die-cast Chassis Driver



Specifications

General Specifications

Nominal diameter.....	305 mm/12 in
Power rating.....	500 W(AES)
Nominal impedance.....	8Ω
Sensitivity.....	96 dB
Frequency range.....	60-3000 Hz
Chassis type.....	Cast aluminum
Magnet type.....	Neodymium
Magnet weight.....	0.33 kg/11.7 oz
Voice coil diameter.....	82.5 mm/3.25 in
Coil material.....	CCA-W
Former material.....	Glass fiber
Cone material.....	Paper
Surround material.....	Cloth
Suspension.....	Single
X-max.....	4.8 mm/0.19 in
Gap depth.....	10 mm/0.39 in
Voice coil winding width.....	19.6 mm/0.77 in
Net Weight.....	4.1 kg/11.0 lb
Packing Dimension WxDxH.....	355 x 355 x 195 mm
Shipping Weight.....	5.0 kg/11.0 lb

Small Signal Parameters

Re.....	5.5Ω
Fs.....	68 Hz
Mms.....	68.23 g/2.41 oz
Mmd.....	60.78 g/2.14 oz
Qms.....	5.34
Qes.....	0.41
Qts.....	0.38
Vas.....	34.82 lt/1.23 ft ³
Bl.....	19.67 Tm
Cms.....	8.2e-05 m/N
Rms.....	5.46 Ns/m
Le (at 1kHz).....	0.45 mH
Sd.....	552 cm ²

Features

- 3.25" Voice Coil
- 2000 Watts Peak Power Handling
- Neodymium Magnetics
- Precision Inside/Outside Wire Geometry
- Die Cast Aluminum Chassis

Applications

The P Audio SN12-500B is a high performance wide bandwidth transducer. The SN12-500B is an upgraded design that features many of P Audio's new technologies and performance upgrades. The 12 inch (305mm) diameter piston will produce extremely high sound pressure levels at both low and mid band frequencies and is ideal for high level response in both live sound and recorded music venues. The transducer uses very high energy neodymium magnetics to achieve a very high acoustic output to weight ratio. The Sn12-500B has been optimized for use in two way or three way sound reinforcement systems and has an operating range of 60Hz to 3000Hz.

The SN12-500B features a large 3.25 inch (82.5mm) diameter voice coil that provides an AES rated 500 watts of continuous power handling and a full 2000 watts of peak rated power handling when sufficient amplifier headroom is available. The SN12-500B utilizes P Audio's Auto Balanced Cooling (ABC) technology to not only improve transducer power handling and reliability but to also increase power compression performance by carefully balancing and directing airflow to critical areas.

The voice coil design is a bobbin wound geometry with P Audio's inside/outside wire technology to improve conversion efficiency and provide a large cross-sectional area for superior cooling.

The transducer chassis is a die cast aluminum design that insures a very high degree of structural integrity.

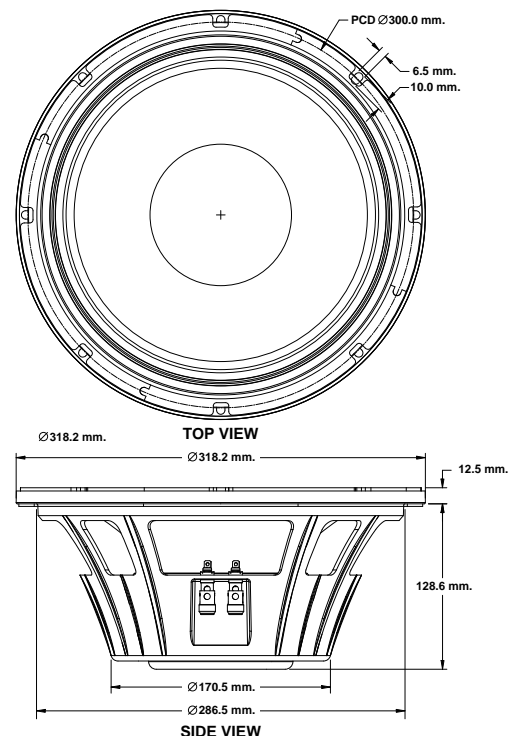

Frequency Response and Impedance Curves

