

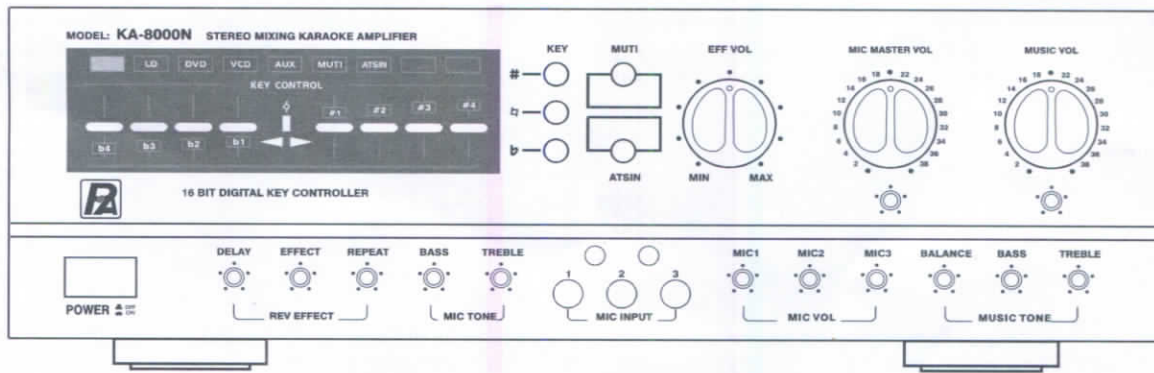

# STEREO MIXING KARAOKE AMPLIFIER MODEL:KA-8000N

## Owner's Manual

Thank you for purchasing this unit. To make full and effective use of this unit, please read this owners manual carefully before operation this unit.  
After reading retain this booklet together with the warranty card for future use in case of difficulty or trouble.



### CONTENTS

SAFTY PRECAUSIONS	1	CONNECTIONS	5
FEATURES	2	SYSTEM CONNECTIONS	6
HANDLING PRECAUTIONS	2	OPERATION	7
BEFORE CONNECTIONS	2	SPECIFICATONS	8
NAMES OF PARTS AND THEIR FUNCTIONS (FRONT PANEL)	3		
NAMES OF PARTS AND THEIR FUNCTIONS (REAR MANEL)	4		

# SAFETY PRECAUTIONS

## In case of abnormality

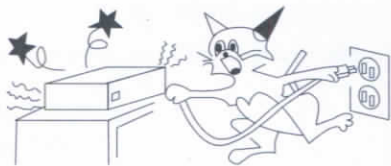

In case of abnormality in case an abnormal noise or smell is generated from the unit during use, immediately switch the power of, unplug the power cord from the power outlet, and consult your dealer or an authorized service center for a check-up.

## Keep away from water and foreign objects.



Do not insert or drop metallic objects, such as a hairpin, nail and coin, or flammable objects, such as paper and matches, through the ventilation holes or other openings on the unit, for this will cause malfunction or hazard of fire and electric shock. In case water or a foreign object enters inside the unit, consult an authorized service center or your dealer for a check-up.

## Do not open the unit.



Hith-voltage components are used inside the unit. Do not open the cabinet to check or modify the unit, for this will cause the danger of electric shock. Performance degradation or malfunction due to the user modification will not be covered by the warranty.

## Do not damage the power cord.



Hold the power plug when plugging or unplugging the power cord. Do not pull the cord or touch in with wet hands, for this may cause short-circuit or or electronic hazard. Do not leave the power cord under this unit. Or under furniture, or between objects

## Do not exceed the maximum power capacity.



The components equipped with the rear panel AC OUT-LETS accept the connection of other stereo system components. However, do not connect competes the total power consumption of which exceed the power capacity marked on the panel, for this may cause malfunction of fire hazard. Also note that components in which large current flows when the power is switched on, such as a TV, cannot be connected to such an AC outlet unless it has been designed to accept the connection of a TV set.

## When the unit is not to be used for a long period.



These openings must not be blocked or covered. If they are blocked or covered accidentally, the inside temperature will rise, and cause a fire. There are ventilation openings on upper and bottom of the case to prevent overheating.

# FEATURES

---

- Power output 200W+200W (8 ohms)
- Four line inputs function manually.
- Built-in high quality digital echo.
- Five microphones available simultaneously.
- Built-in key controller allows to transpose the key of music over 2.5 tones, in +4 positions.
- Wireless remote controller  
(Control of Music Microphone, Echo, Key controller.)

# HANDLING PRECAUTIONS

---

## Do not install the unit in following places....

- In a place which is exposed to direct sunlight or near a source of heat such as a radiator.
- In a place where the heat cannot escape due to poor ventilation, or where is very humid or dusty.
- In a unstable place with excessive vibrations or sloping.
- In a place which may be exposed to rain, such as near a window.
- In a place which may be exposed to soot, vapor or heat, such as near a cooking table.

# BEFORE CONNECTIONS

---

## Connection precautions

- Be sure to switch the powers of the related equipment before making any connection
- the white input/out jacks for the amplifier are designed for the left channel, while the red jacks are for the right channel. Be sure to connect the cords without mistaking the correspondences of the left and right channels.
- Insert the plug of the connection cords securely into the jacks. If the connection is incomplete, sound may not be produced or noise may be generated.
- When unplugging the power cord from the power outlet, be sure to grasp the plastic molding of the plug and pull.

## Power consumption of AC power outlets

- Be careful that the total power consumption does not exceed the wattage marked on the rear panel. Do not connect other appliances than the system components to the power outlets of this unit.
- Do not connect a TV set to this until even if the power consumption value marked on a TV set is below the permissible limit of this unit, a larger current than the permissible value may flow when the TV power is turned on.

# NAMES OF PARTS AND THEIR FUNCTIONS

[ FRONT PANEL ]

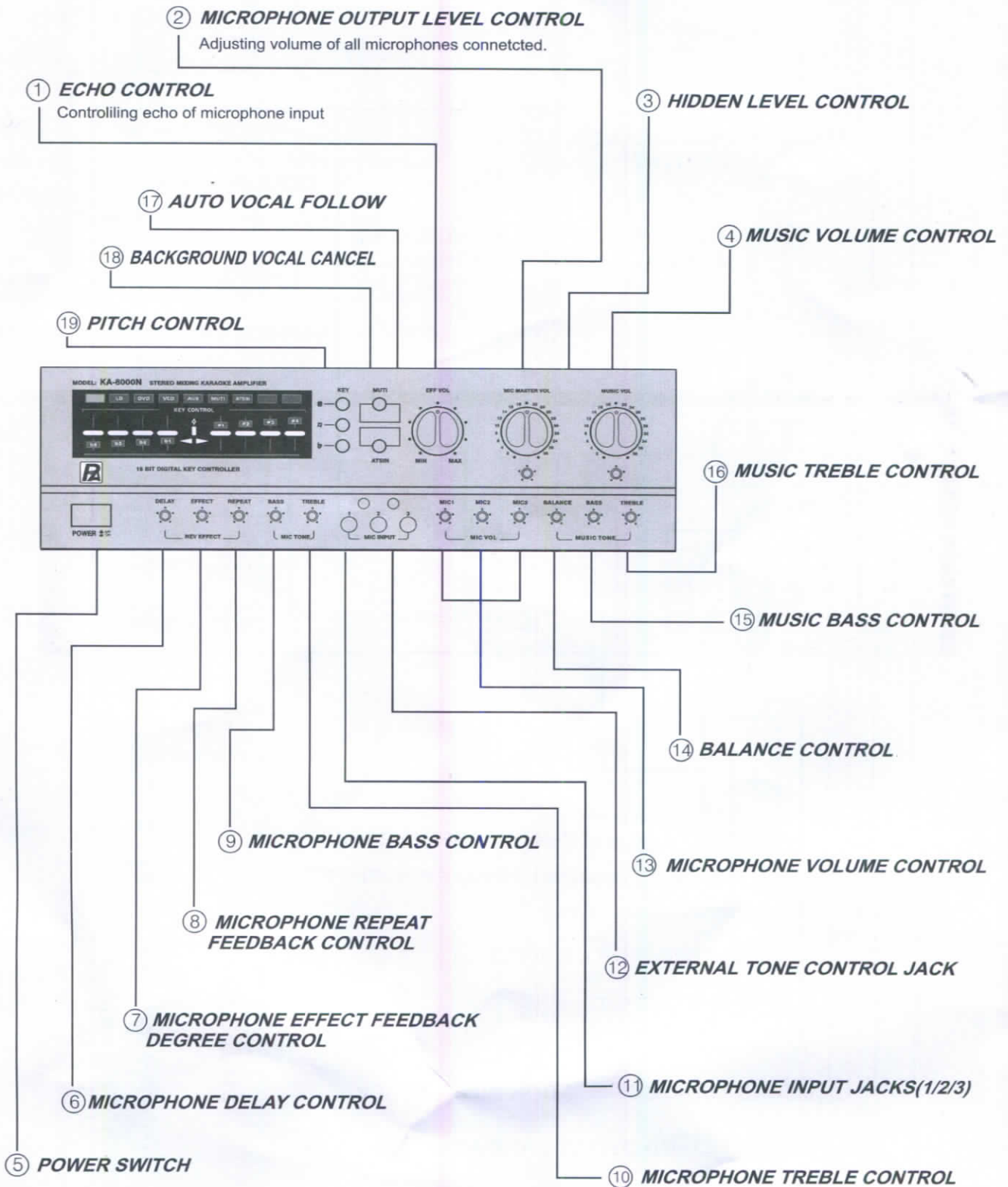

[ REAR PANEL ]

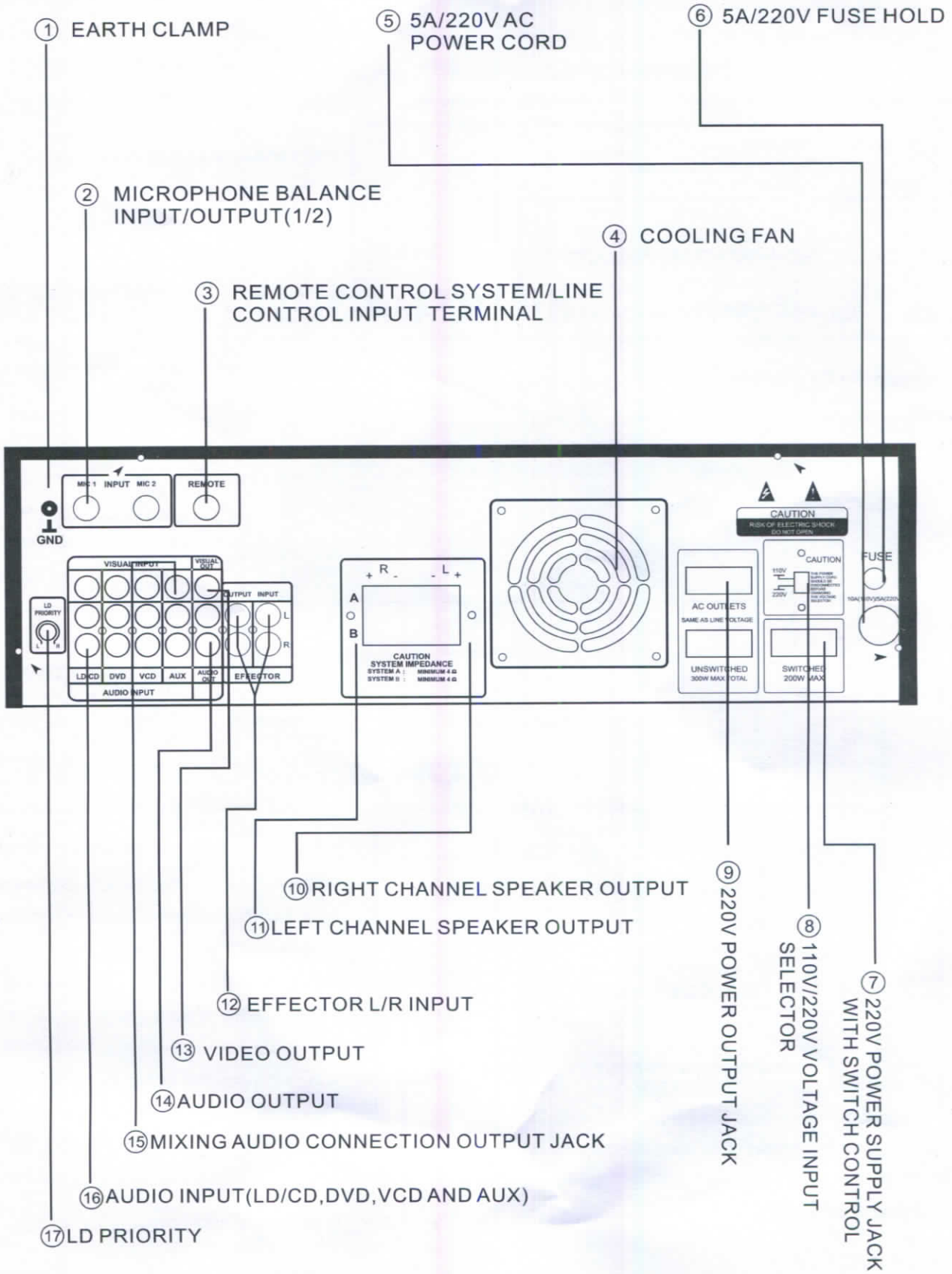

# CONNECTIONS

## CONNECTION OF SPEAKER CORDS

1. Press down the button as illustration, insert the cords into the hole.
  2. Spring of the button will fix the cords.
- Please select the suitable speaker cords and connect it through the shortest path.

This unit could connect one or two group speakers simultaneously. If only connect one group speakers, you can select connect group A or group B. And please note that phase of the speaker cords are correct or not, if not, the sound will be felt unnatural and absence of low frequency.

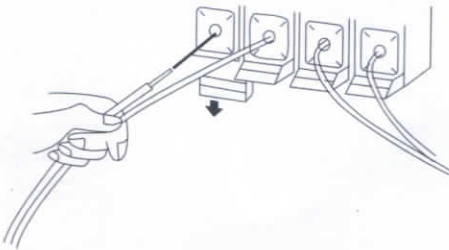

**Attention: ends of the cords should not touch each other.**

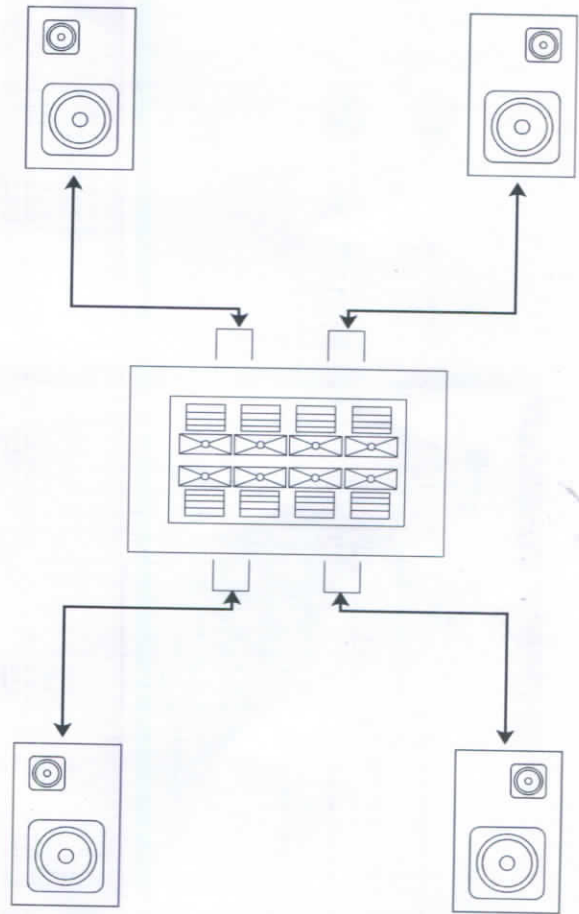

## Connecting the RCA pin plugs

When connecting RCA pin plugs, be sure to insert yellow plug into yellow jack, red plug into the red jack and the white plug into the white jack.

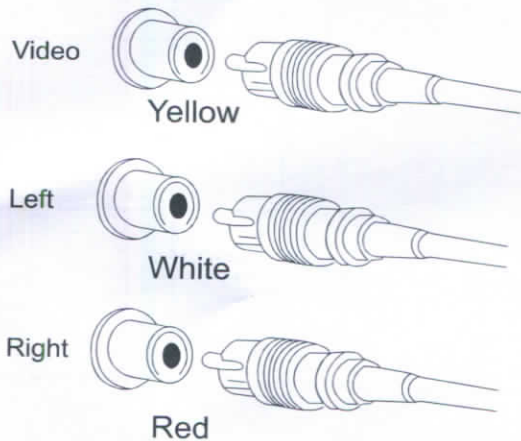

# SYSTEM CONNECTIONS

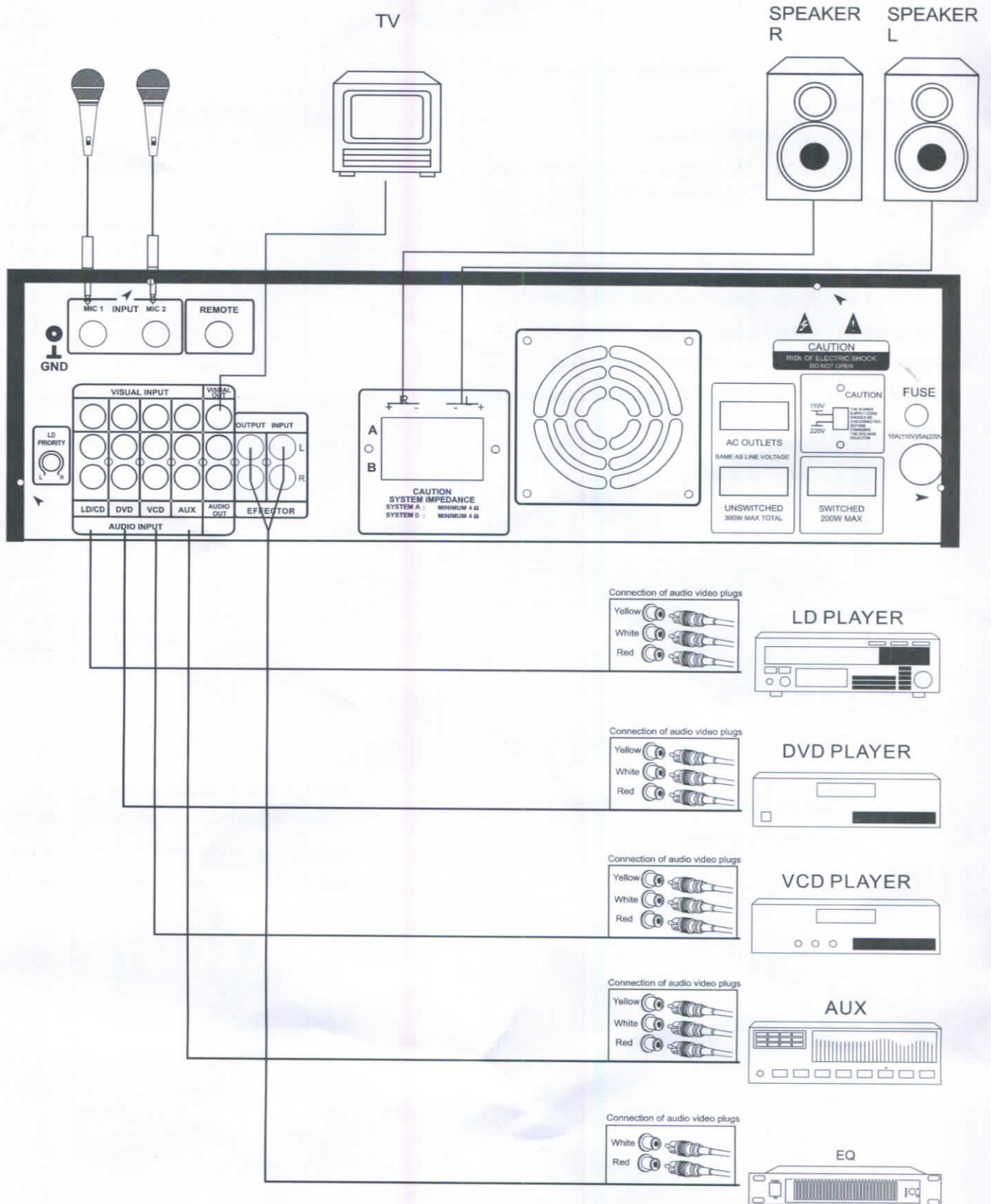

# OPERATION

---

1. Press power switch 5 to turn it on.

2. Insert microphones into microphone input jacks 11, adjust volume by microphone volume control 13.

3. Adjust timbre of human voice:

*Treble: Revolve treble 10 to boost or cut high frequency, note avoid high frequency whistle.*

*Bass Revolve bass 9 to boost or cut low frequency, note avoid low frequency whistle.*

4. Microphone master volume control

Set value of microphone master volume control 2 between 18-20, then operate it from step 2 to step 3.

5. Echo effecton

Set value of echo effecton control 7 in the middle, then adjust delay 6 and repeat 8 and talk simultaneously until you feel satisfied.

6. Select input signal sources.

7. Adjust music volume

Revolve music volume cotrol 4 from left to right until you feel satisfied.

8. Adjust music quality

Adjust high frequency through revolving treble 16 and low frequency through revolving bass 15 until you feel satisfied.

9. Microphones

Keep a certain distance between the microphones and the speakers or decrease the microphone volume when whistle happens.

Keep a certain distance and angle between the microphone and your mouth.

Switch the microphones off and pull it out from jacks when you don't need to use microphones.

10. Whistle inhibition

A: Set the value of microphone volume control 2 between 8-10.

B: Adjust microphone volume and music volume Simultaneously until balance.



# SPECIFICATIONS

※ we reserve the rights to change the function of products. any changes will not be informed.

## Amplifier

Maximum Output(1kHz, 8Ohm) 200W+200W

Total Harmonic Distortion 0.05%

(1kHz, 100W, 8Ohm)

## Input Jacks(Sensitivity/Impedance)

Mic 12mV/2K Ohm

LD,DVD,VCD,AUX 300mV/51K Ohm

## Output Jacks(Output Level/Output Impedance)

PRE-Output 1Vp-p/75 Ohm

## Frequency Responses

Mic 15Khz, +8/-3dB

Music 20KHz,+8/-3dB

## Tone Control Characteristics

Microphone Bass +8/-10dB(100Hz)

Treble +8/-10dB(10KHz)

Music Bass +10dB(100Hz)

Treble +10dB(10KHz)

Key Control Range 9 steps, +2 -1/2 tones

## Video Input jack

(Sensitivity/Input Impedance) 1Vp-p/75Ohm

## Video Output Jack

(Output Level/Output Impedance) 1Vp-p/75Ohm

## Power supply, Etc.

Supply Voltage AC 110V or 220V

50Hz/60Hz

Power Consumption 600W

## AC power outlets

Switched (300W max.) 2

Dimensions(WXHXD) 496x250x454(mm)

Weight 13.5Kg

## Accessories

Owners Maunal 1

Wireless Remote Control 1

Batteries(AA) 2

Fuse(6.3A 125V) 1



**Thank you for purchasing this unit.  
To make full and effective use of this unit, please read this  
Owner's Manual carefully before operating the unit.  
After reading, retain this booklet for future reference.**