

CS 1112 E 240V

CombiSets  
with two electric cooking zones

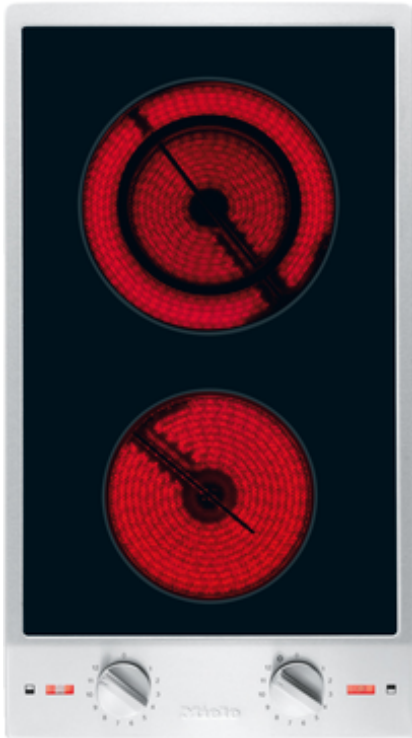

- Professional design – ceramic glass with frame measuring 11 3/8 (288) Inch wide
- Very convenient, safe - operating and residual heat indicator
- Easy and direct controls - operation via metal rotary dial control
- Particularly versatile - 2 cooking zones incl. 1 Vario zone

EAN: 4002514386829 / material number: 07141710

<b>Type of heating</b>	
Fuel type	Electrical
<b>Design</b>	
Print design	LightPrint
All-round stainless steel frame	•
Miele logo embossed in stainless steel	•
<b>Ring features</b>	
No. of rings	2
<b>Ring</b>	
Position	front center
Type	Single-circuit ring
Size in inches (mm)	Ø 145
Max. rating in W	1200
Position	rear center
Type	Variable cooking zone
Size in inches (mm)	Ø 100-180
Max. rating in W	700/1800
<b>Control panel</b>	
Operation via knobs	•
Extended ring area	•
<b>Cleaning convenience</b>	
Easy to clean ceramic surface	•
<b>Safety</b>	
Safety cut-out	•
Overheating protection	•
Residual heat indicator	•
<b>Technical data</b>	
Dimensions in in. (width)	11 3/8 (288)
Dimensions (height) in in.(mm)	2 7/8 (73)
Built-in height with mains connection box in in.(mm)	3 3/4 (95)
Dimensions (depth) in in.(mm)	20 1/2 (520)
Cutout dimensions in in. (width) with proud-mounted installation	10 3/4 (272)
Cutout dimensions in in. (depth) with proud-mounted installation	19 3/4 (500)
Weight in lbs. (kg)	15 (7)
Total connected load in kW	3.0
Power cord length in m	3 (1.2)
<b>Standard accessories</b>	
Razor-blade scraper	•
Connection wire	•

CS 1112 E 240V

CombiSets  
with two electric cooking zones

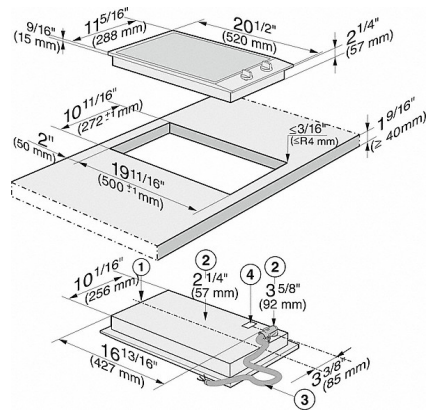
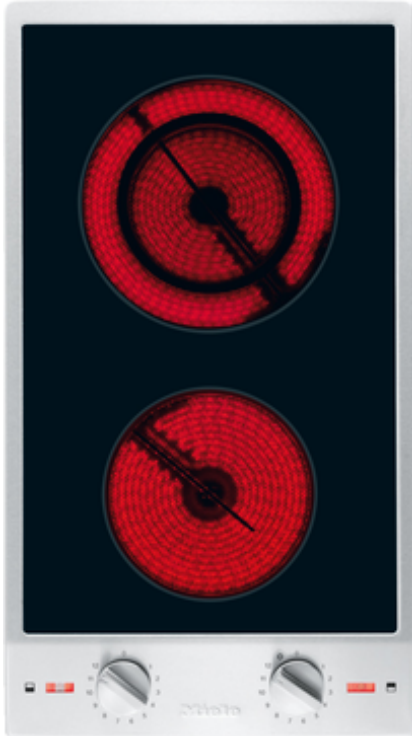

CS 1112 E (Installation drawing) - USA

- 1) Appliance front
- 2) Installation height
- 3) Power supply box with Connection cable, L = 78 3/4" (2000 mm)
- 4) Rating label