

BEFORE YOU BEGIN

- All information is based on the latest product information available at the time of publication. Kohler China Ltd. reserves the right to make changes in product characteristics, packaging, or availability at any time without notice.
- These instructions contain important care, cleaning, and warranty information—**please leave these instructions for the consumer.**
- Make sure that the bath and the finished wall material are completely and correctly installed prior to installing your shower door. Prepare waterproof layer to wall and floor of the showering area. It is not allowed for any presence of electric switches and sockets. Make sure the floor drain runs smoothly.
- Before starting the door installation, lay out and identify all the parts. Use the exploded view illustrated on page 2 for reference.
- For the installation method of customized shower with different dimensions, please refer to this instructions.
- The product complies with QB 2584-2007.

⚠ CAUTION: Risk of injury or product damage.
Tempered glass cannot be cut, drilled or knocked by hard object. Make sure corner area of the glass refraining from knocking so as to cause personal injury due to broken glass.

ATTENTION: Please install this door on Kohler receptors or curbs(Not included). If the curb is not Kohler-branded, please note its top width should be more than 80mm.

IMPORTANT: The shower door requires a flat vertical finished wall. The squareness of the wall is recommended no more than 3 mm/m. KOHLER Company won't take responsibility of the installation quality.

Do not use the enclosure for at least 24 hours.
安装后 24 小时内请勿使用淋浴房。



安装之前

- 说明书中所有的资料是按最新出版的产品资料编写而成。科勒中国有限公司保留任何时候无须通知即可改变产品特性、包装或产品可供类型的权利。
- 说明书包括重要的安装、清洁及保养方面的内容，**请把这些资料交给用户阅读，保管。**
- 确保在安装淋浴房之前已经完整正确地安装了浴室和完工墙面材料。淋浴区墙地面应做防水处理，并不得布置有电器开关、插座。确保地面排水通畅。
- 在进行淋浴房安装之前，请拿出、排列并确认所有的零部件。请参考第 2 页上所示的分解图。
- 对尺寸与本标准产品不同的定制淋浴房，参照本说明书进行安装。
- 本产品符合 QB 2584-2007。

⚠ 警告：可能有人伤害或者产品损坏的危险。
钢化玻璃不能进行切割，钻孔或硬物敲击。搬移或安装过程中，小心确保玻璃边、角部位不受撞击，以防爆裂伤人。

建议：将本产品安装在科勒淋浴盆或挡水条上（需另行购买）。如自备挡水条，建议顶面宽度尺寸大于 80mm。

重要事项：淋浴房需要安装在平坦垂直的墙面上。墙面的垂直度推荐在正负 3mm/m 以内。如果超出此范围，科勒公司将不保证淋浴房的完美使用。

ROUGHING-IN

尺寸图

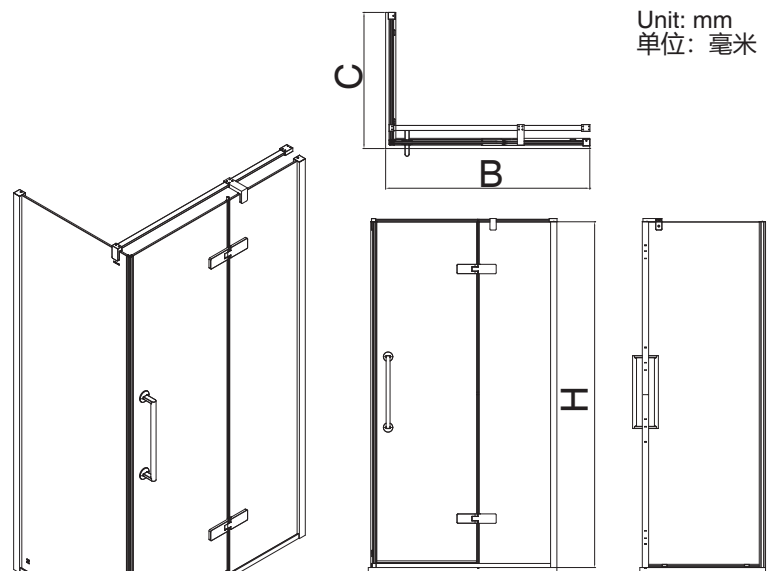

SKU	B	C	H
K-701803T	1000-1600	250-1100	1850-2200

ZHONGSHAN KOHLER SHOWER CO., LTD. NO13-1, XINGYE ROAD, ZHONGSHAN TORCH DEVELOPMENT ZONE, ZHONGSHAN, GUANGDONG, CHINA POST CODE: 528437
中山科勒卫浴有限公司 广东省中山市中山火炬开发区兴业路 13-1 号 邮编: 528437

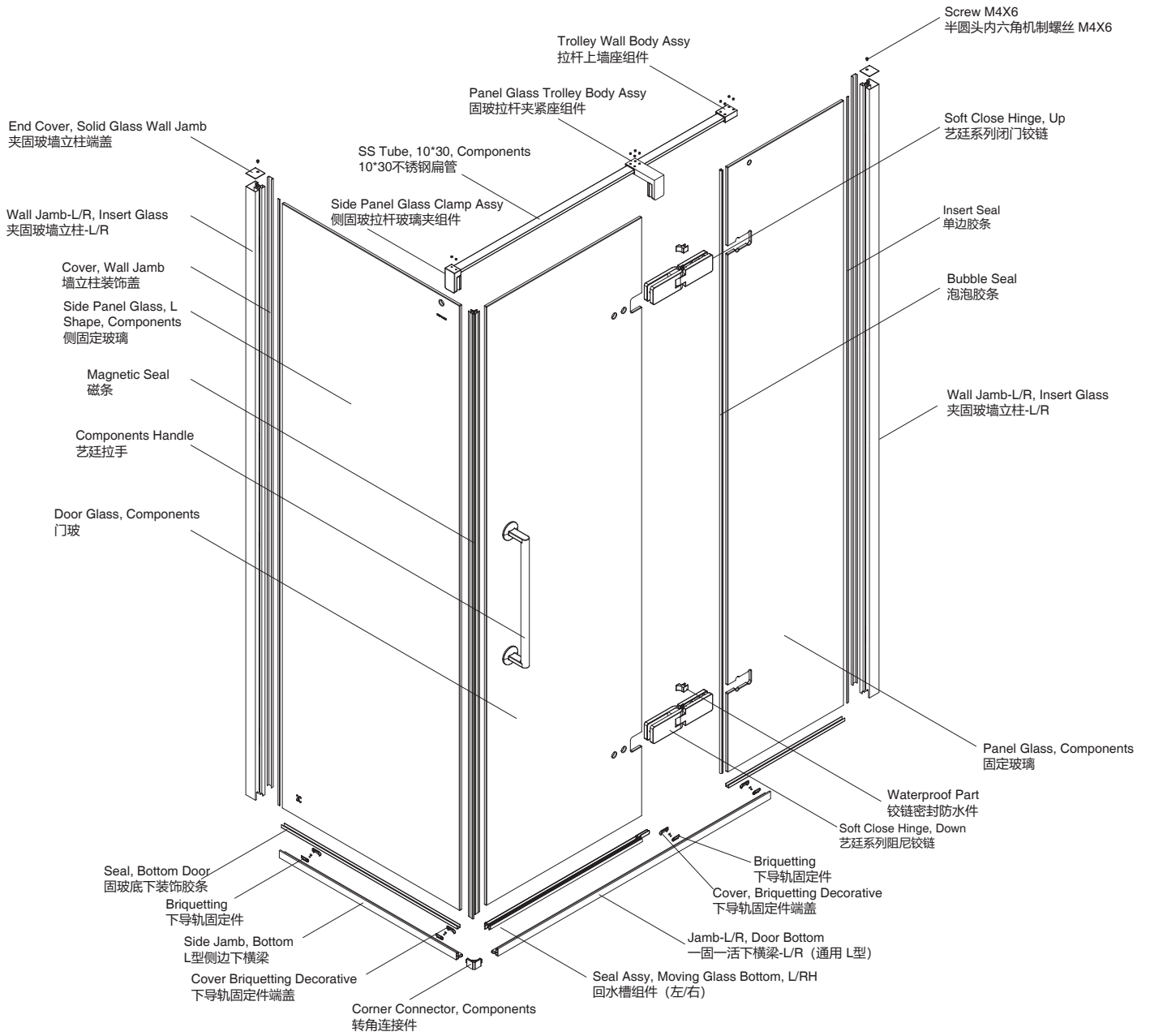

	X2	Wall Jamb-L/R, Insert Glass 夹固玻璃墙立柱-L/R
	X1	Jamb-L/R, Door Bottom 一固一活下横梁-L/R
	X2	Cover, Wall Jamb 墙立柱装饰盖
	X1	Soft Close Hinge, Up 艺廷系列闭门铰链
	X1	Soft Close Hinge, Down 艺廷系列阻尼铰链
	X2	Trolley Wall Body Assy 拉杆上墙座组件
	X1	Panel Glass Trolley Body Assy 固玻拉杆夹紧座组件
	X1	Side Panel Glass Clamp Assy 侧固玻拉杆玻璃夹组件
	X1	SS Tube, 10*30, Components 10*30不锈钢扁管
	X4	Cover, Briquetting Decorative 下导轨固定件端盖
	X4	Briquetting 下导轨固定件
	X1	Components Handle 艺廷拉手

	X2	End Cover, Solid Glass Wall Jamb 夹固玻璃墙立柱端盖
	X1	Seal Assy, Moving Glass Bottom, L/RH 回水槽组件 (左右)
		Magnetic Seal 磁条 Bubble Seal 泡泡胶条 Insert Seal 单边胶条 Seal, Bottom Door 固玻底下装饰胶条
	X4	Screw GB/T 819 M4X10 十字槽沉头不锈钢机制螺丝 M4X10
	X10	Pan Screw ST3.5X40 圆头螺丝 ST3.5X40
	X4	Screw M4X6 半圆头内六角机制螺丝 M4X6
	X1	Screw Key 4mm 内六角扳手 4mm
	X1	Screw Key 3mm 内六角扳手 3mm
	X1	Screw Key 2.5mm 内六角扳手 2.5mm

Tools Required/所需工具

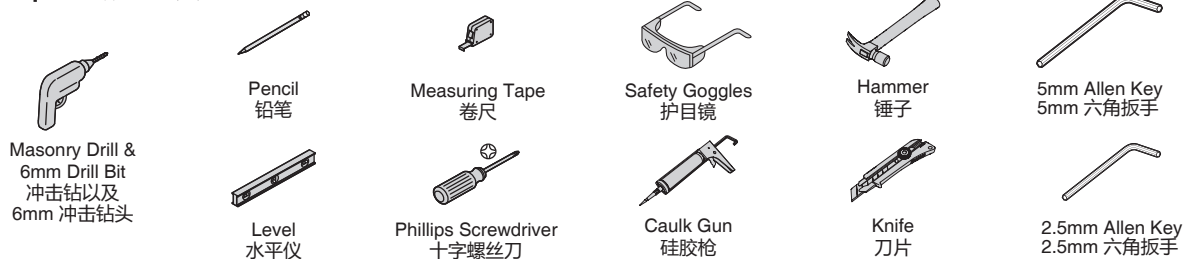

1. Place the weather bar. The installation surface in the shower room must be flat.
1. 放置挡水条，淋浴房安装面必须打水平。

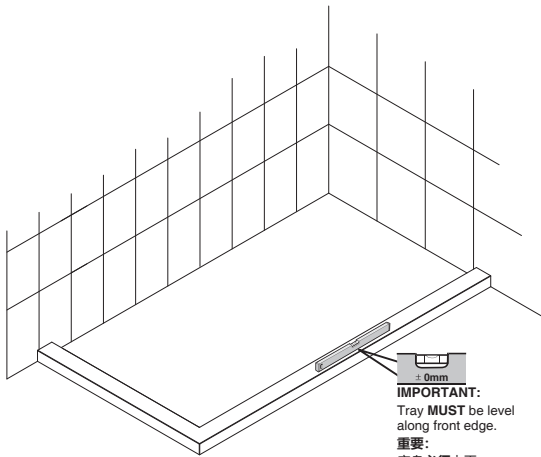

IMPORTANT:
Tray **MUST** be level along front edge.
重要:
底盘必须水平。

STEP 1

1. Install the bottom frame (20 mm to the edge from the inside). Fix the wall jambs on both ends and make sure that a minimum gap exists between the jambs and the bottom frame.
IMPORTANT: Make sure that the rubber washer is present on the inter glass jambs.
1. 安装底横梁（内偏20mm安装），固定两端上墙型材，请确保上墙型材固定时与底横梁之间间隙最小。
重要: 安装前确保夹固型型材的垫片胶垫不掉落。

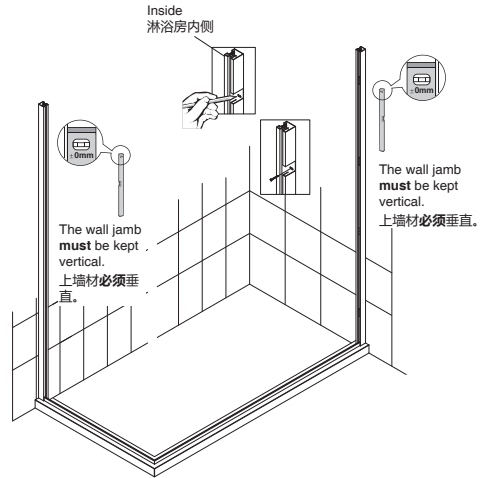

The wall jamb must be kept vertical.
上墙材必须垂直。

The wall jamb must be kept vertical.
上墙材必须垂直。

STEP 2

1. Insert the panel glass into the stainless steel jambs.
2. Adjust the two panel glasses so that they are 665 mm apart (see the figure below).
3. Secure the panel glasses as shown in the figure below.

IMPORTANT: Check that the protective seal has been installed on the bottom of the glasses and check the installation position and dimension.

1. 将固玻插入到不锈钢型材里。
2. 按图示要求调节两片玻璃之间的距离为665mm（如下图）。
3. 按下图方式将固玻固定好。

重要: 在安装固玻前，请确认固玻底下是否安装防护胶条及胶条安装在固玻上的位置尺寸。

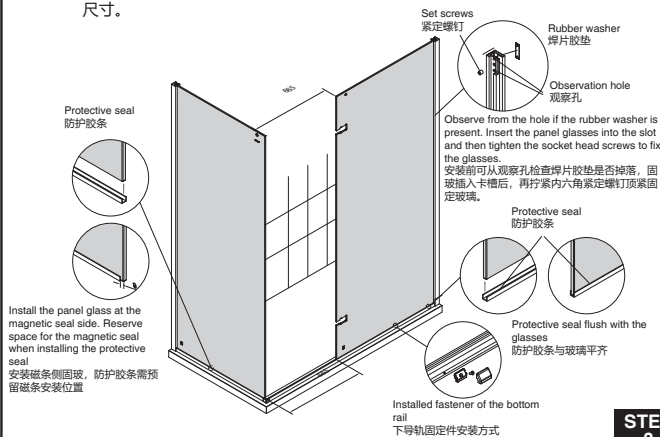

Observe from the hole if the rubber washer is present. Insert the panel glasses into the slot and then tighten the socket head screws to fix the glasses.
安装前可从观察孔检查垫片胶垫是否掉落，固玻插入卡槽后，再拧紧内六角固定螺钉固定玻璃。

Install the panel glass at the magnetic seal side. Reserve space for the magnetic seal when installing the protective seal.
安装磁条侧固玻，防护胶条需预留磁条安装位置

Installed fastener of the bottom rail
下导轨固定件安装方式

STEP 3

1. Drill the installation holes into the wall according to the dimensions shown in the figure below.
2. Install the handle.

1. 按下图尺寸在墙面钻好安装孔。
2. 安装拉杆。

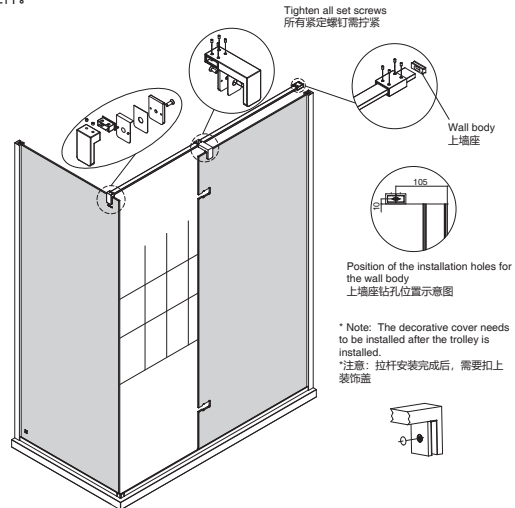

Tighten all set screws
所有固定螺钉需拧紧

Wall body
上墙座

Position of the installation holes for the wall body
上墙座钻孔位置示意图

* Note: The decorative cover needs to be installed after the trolley is installed.
*注意：拉杆安装完成后，需要扣上装饰盖

STEP 4

1. Insert the insert seal between the inner side of the panel glasses and the jambs.
2. Loosen the lock screws on the inside of the hinge. Insert the adjusting mechanism into the opening of the glasses (make sure that the plastic cover and the plastic washers on both sides of the glasses are present before installation). Lock the hinges onto the panel glasses. Tighten the upper and the lower adjust screws while keeping the hinge horizontal. Then tighten the connecting screws on the internal cover.

1. 在固定玻璃内侧与型材间卡入单边胶条；
2. 松开铰链内侧锁板螺丝，将合页调节件卡入玻璃开口内（安装前需确保调节塑胶套无脱落，玻璃两侧的塑胶垫片无遗漏。）将合页锁至固定玻璃上。当合页处于水平状态时拧紧上下两个调节螺丝，最后锁紧内侧盖板的连接螺丝。

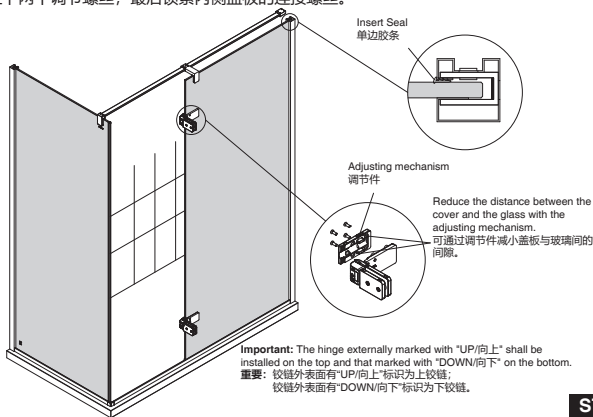

Important: The hinge externally marked with "UP/向上" shall be installed on the top and that marked with "DOWN/向下" on the bottom.
重要: 铰链外表面有"UP/向上"标识为上铰链；铰链外表面有"DOWN/向下"标识为下铰链。

STEP 5

1. Adjust the closing angle with the set screw.

1. 通过拧紧螺钉调整好关门的角度。

TIPS:

1. The room must be sufficiently supported before the door glass is installed.
2. Four set screws on the top hinge need to be loosened when the door glass is being removed, otherwise the hinge may rebound and cause the glass to break.

温馨提示:

1. 门玻安装前，房体必须要有足够的支撑；
2. 拆卸淋浴房门玻时，需松开上铰链的四颗调节紧定螺钉，防止铰链回弹引起玻璃爆裂。

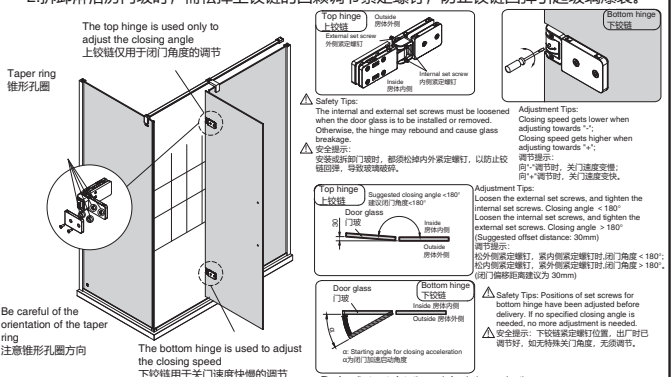

The top hinge is used only to adjust the closing angle
上铰链仅用于关门角度的调节

Taper ring
锥形孔圈

Be careful of the orientation of the taper ring
注意锥形孔圈方向

The bottom hinge is used to adjust the closing speed
下铰链用于关门速度快慢的调节

Safety Tips:
The internal and external set screws must be loosened when the door glass is to be installed or removed. Otherwise, the hinge may rebound and cause glass breakage.
安全提示:
安装拆卸门玻时，必须松开内外固定螺钉，以防门玻反弹，导致玻璃破碎。

Adjustment Tips:
Closing speed gets lower when adjusting towards "+".
Closing speed gets higher when adjusting towards "-".
调节提示:
向"+"调节时，关门速度变慢；向"-"调节时，关门速度变快。

Top hinge
上铰链
Suggested closing angle < 180°
建议关门角度 < 180°
Loosen the internal set screws, and tighten the external set screws. Closing angle > 180° (Suggested offset distance: 30mm)
调节提示:
松开内部固定螺钉，紧外部固定螺钉时，关门角度 > 180°，(建议偏移距离为: 30mm)

Door glass
门玻
α: Starting angle for closing acceleration
α: 开始加速关门的角度

Bottom hinge
下铰链
Safety Tips: Positions of set screws for bottom hinge have been adjusted before delivery. If no specified closing angle is needed, no more adjustment is needed.
安全提示: 下铰链固定螺钉位置，出厂时已调节好，如无特殊关门角度，无须调节。

Tips for adjustment of starting angle for closing acceleration:
Loosen the external set screws, and tighten the internal set screws.
Starting angle < α
Loosen the internal set screws, and tighten the external set screws.
Starting angle > α
调节开始加速关门角度提示:
松开外部固定螺钉，紧内部固定螺钉时，启动角度 < α;
松开内部固定螺钉，紧外部固定螺钉时，启动角度 > α。

STEP 6

1. Check that the stopper is properly installed and then install the internal and the external hinge covers.
1. 检查铰链限位件是否已预装好，确认后扣上铰链内外侧盖板；

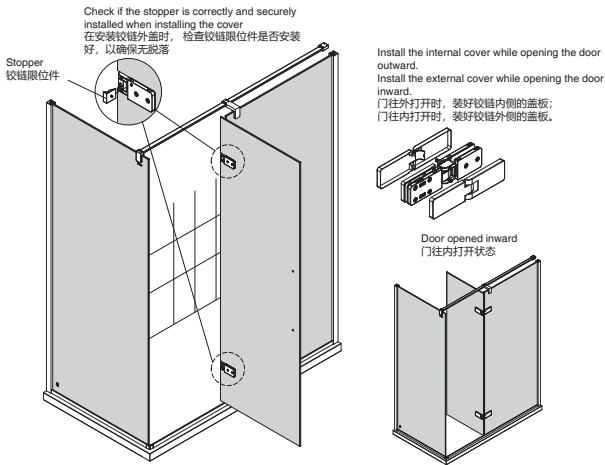

STEP
7

1. Install the magnetic seal and the weather bar.
IMPORTANT: Install the hinge cover before the side weather bar.
1. 装好磁条，挡水胶条。
重要：在安装侧挡水胶条前，先扣好铰链盖板。

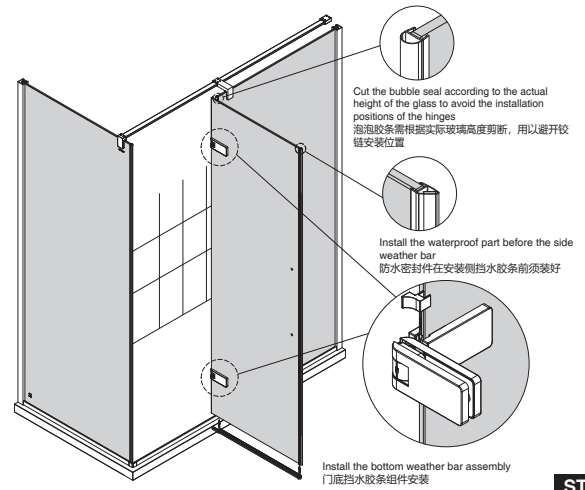

STEP
8

1. Install decorative covers on all jambs.
2. Install the handle assembly onto the door glass.
1. 将型材装饰盖全部装好；
2. 将把手组件安装在门玻上。

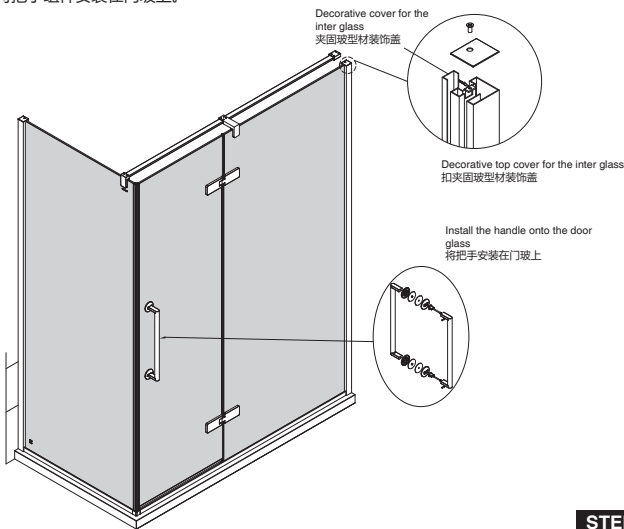

STEP
9

1. Apply glass cement both inside and outside as shown in the figure below.
1. 按下图所示，在淋浴房里外都打上玻璃胶。

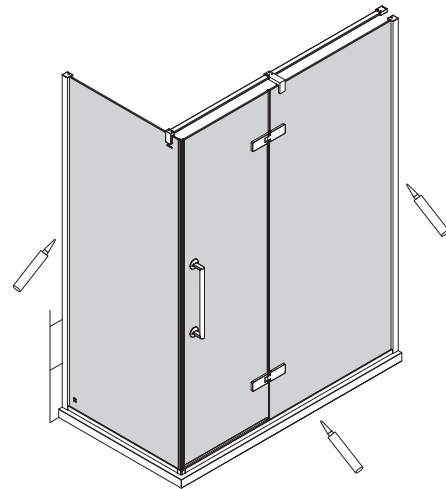

STEP
10