

SKF Power transmission products



Contents

5–47

Belts

- 6 Wrapped wedge belts
- 10 Wrapped classical belts
- 15 Wrapped narrow wedge belts
- 16 Cogged raw edge wedge belts
- 18 Cogged raw edge classical belts
- 20 Cogged raw edge narrow wedge belts
- 21 Banded wedge belts
- 22 Banded classical belts
- 23 Banded narrow wedge belts
- 24 Double classical (Hex) belts
- 25 Ribbed belts
- 28 Classical timing belts
- 33 Double-sided classical timing belts
- 36 HiTD belts
- 40 Double-sided HiTD belts
- 42 Metric timing belts
- 46 Double-sided metric timing belts

49–74

Chains

- 50 Roller chains
- 61 Oil field chains
- 62 Double pitch chains
- 65 Conveyor chains
- 66 Engineering chains
- 67 Silent chains
- 69 Leaf chains

75–94

Couplings

- 76 SKF Flex couplings
- 80 SKF Flex spacer couplings
- 81 Gear couplings
- 82 Grid couplings
- 84 Chain couplings
- 86 Rigid couplings
- 87 FRC couplings
- 90 Jaw couplings
- 94 Universal joints

95–103

Bushings and Hubs

- 96 Taper bushings
- 99 Weld-on hubs
- 100 Bolt-on hubs / adapters
- 101 QD Bushings

105–189

Sprockets

- 106 Metric sprockets
- 152 ANSI sprockets

191–301

Pulleys

- 193 Wedge belt pulleys
- 207 Classical V-belt pulleys
- 214 Narrow wedge belt pulleys
- 222 HiTD pulleys
- 242 Classical timing pulleys
- 264 Metric timing pulleys
- 280 QD Classical V-belt pulleys
- 291 QD Narrow wedge belt pulleys

303–311

Smart tools

- 304 Belt tools
- 306 Belt alignment tools
- 307 Shaft alignment tools
- 311 Inspection tool



The SKF® brand now stands for more than ever before, and means more to you as a valued customer.

While SKF maintains its leadership as the hallmark of quality bearings throughout the world, new dimensions in technical advances, product support and services have evolved SKF into a truly solutions-oriented supplier, creating greater value for customers.

These solutions encompass ways to bring greater productivity to customers, not only with breakthrough application-specific products, but also through leading-edge design simulation tools and consultancy services, plant asset efficiency maintenance programmes, and the industry's most advanced supply management techniques.

The SKF brand still stands for the very best in rolling bearings, but it now stands for much more.

SKF – the knowledge engineering company

www.skfptp.com

Belts

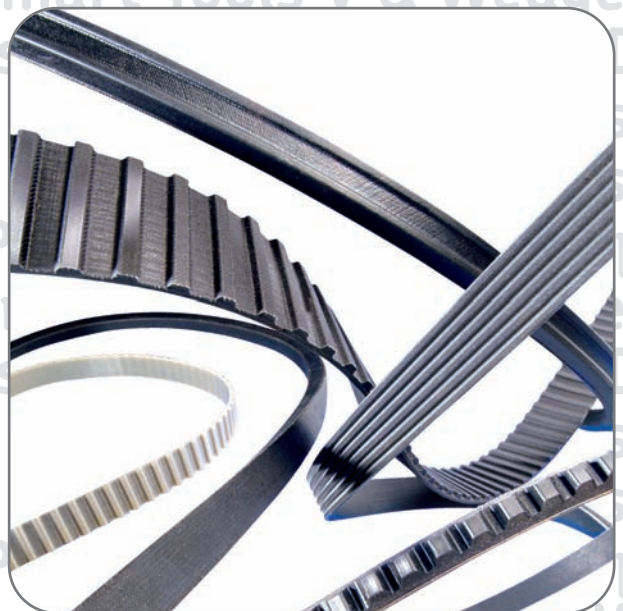



Wrapped wedge belts

SPZ



SPZ Section

Belt marking	Pitch length	Designation	Belt marking	Pitch length	Designation
	mm			mm	
SPZ512	512	PHG SPZ512	SPZ1347	1347	PHG SPZ1347
SPZ560	560	PHG SPZ560	SPZ1362	1362	PHG SPZ1362
SPZ562	562	PHG SPZ562	SPZ1387	1387	PHG SPZ1387
SPZ587	587	PHG SPZ587	SPZ1400	1400	PHG SPZ1400
SPZ612	612	PHG SPZ612	SPZ1412	1412	PHG SPZ1412
SPZ630	630	PHG SPZ630	SPZ1420	1420	PHG SPZ1420
SPZ637	637	PHG SPZ637	SPZ1437	1437	PHG SPZ1437
SPZ662	662	PHG SPZ662	SPZ1462	1462	PHG SPZ1462
SPZ670	670	PHG SPZ670	SPZ1487	1487	PHG SPZ1487
SPZ687	687	PHG SPZ687	SPZ1500	1500	PHG SPZ1500
SPZ710	710	PHG SPZ710	SPZ1512	1512	PHG SPZ1512
SPZ722	722	PHG SPZ722	SPZ1520	1520	PHG SPZ1520
SPZ737	737	PHG SPZ737	SPZ1537	1537	PHG SPZ1537
SPZ750	750	PHG SPZ750	SPZ1562	1562	PHG SPZ1562
SPZ760	760	PHG SPZ760	SPZ1587	1587	PHG SPZ1587
SPZ762	762	PHG SPZ762	SPZ1600	1600	PHG SPZ1600
SPZ772	772	PHG SPZ772	SPZ1612	1612	PHG SPZ1612
SPZ787	787	PHG SPZ787	SPZ1637	1637	PHG SPZ1637
SPZ800	800	PHG SPZ800	SPZ1650	1650	PHG SPZ1650
SPZ812	812	PHG SPZ812	SPZ1662	1662	PHG SPZ1662
SPZ825	825	PHG SPZ825	SPZ1687	1687	PHG SPZ1687
SPZ837	837	PHG SPZ837	SPZ1700	1700	PHG SPZ1700
SPZ850	850	PHG SPZ850	SPZ1737	1737	PHG SPZ1737
SPZ862	862	PHG SPZ862	SPZ1750	1750	PHG SPZ1750
SPZ875	875	PHG SPZ875	SPZ1762	1762	PHG SPZ1762
SPZ887	887	PHG SPZ887	SPZ1787	1787	PHG SPZ1787
SPZ900	900	PHG SPZ900	SPZ1800	1800	PHG SPZ1800
SPZ912	912	PHG SPZ912	SPZ1812	1812	PHG SPZ1812
SPZ925	925	PHG SPZ925	SPZ1837	1837	PHG SPZ1837
SPZ937	937	PHG SPZ937	SPZ1850	1850	PHG SPZ1850
SPZ950	950	PHG SPZ950	SPZ1862	1862	PHG SPZ1862
SPZ962	962	PHG SPZ962	SPZ1887	1887	PHG SPZ1887
SPZ987	987	PHG SPZ987	SPZ1900	1900	PHG SPZ1900
SPZ1000	1000	PHG SPZ1000	SPZ1937	1937	PHG SPZ1937
SPZ1010	1010	PHG SPZ1010	SPZ1950	1950	PHG SPZ1950
SPZ1012	1012	PHG SPZ1012	SPZ1987	1987	PHG SPZ1987
SPZ1024	1024	PHG SPZ1024	SPZ2000	2000	PHG SPZ2000
SPZ1037	1037	PHG SPZ1037	SPZ2037	2037	PHG SPZ2037
SPZ1047	1047	PHG SPZ1047	SPZ2060	2060	PHG SPZ2060
SPZ1060	1060	PHG SPZ1060	SPZ2120	2120	PHG SPZ2120
SPZ1077	1077	PHG SPZ1077	SPZ2137	2137	PHG SPZ2137
SPZ1080	1080	PHG SPZ1080	SPZ2160	2160	PHG SPZ2160
SPZ1087	1087	PHG SPZ1087	SPZ2187	2187	PHG SPZ2187
SPZ1112	1112	PHG SPZ1112	SPZ2240	2240	PHG SPZ2240
SPZ1120	1120	PHG SPZ1120	SPZ2262	2262	PHG SPZ2262
SPZ1137	1137	PHG SPZ1137	SPZ2280	2280	PHG SPZ2280
SPZ1140	1140	PHG SPZ1140	SPZ2287	2287	PHG SPZ2287
SPZ1150	1150	PHG SPZ1150	SPZ2360	2360	PHG SPZ2360
SPZ1162	1162	PHG SPZ1162	SPZ2410	2410	PHG SPZ2410
SPZ1180	1180	PHG SPZ1180	SPZ2500	2500	PHG SPZ2500
SPZ1187	1187	PHG SPZ1187	SPZ2540	2540	PHG SPZ2540
SPZ1200	1200	PHG SPZ1200	SPZ2580	2580	PHG SPZ2580
SPZ1202	1202	PHG SPZ1202	SPZ2650	2650	PHG SPZ2650
SPZ1212	1212	PHG SPZ1212	SPZ2690	2690	PHG SPZ2690
SPZ1237	1237	PHG SPZ1237	SPZ2800	2800	PHG SPZ2800
SPZ1250	1250	PHG SPZ1250	SPZ2840	2840	PHG SPZ2840
SPZ1262	1262	PHG SPZ1262	SPZ2900	2900	PHG SPZ2900
SPZ1270	1270	PHG SPZ1270	SPZ3000	3000	PHG SPZ3000
SPZ1287	1287	PHG SPZ1287	SPZ3150	3150	PHG SPZ3150
SPZ1312	1312	PHG SPZ1312	SPZ3170	3170	PHG SPZ3170
SPZ1320	1320	PHG SPZ1320	SPZ3350	3350	PHG SPZ3350
SPZ1337	1337	PHG SPZ1337	SPZ3550	3550	PHG SPZ3550
SPZ1340	1340	PHG SPZ1340	-	-	-

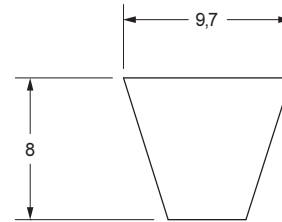

Non-standard lengths are also available.



Wrapped wedge belts

SPA

- ▶ Belts
- ▶ Chains
- ▶ Couplings
- ▶ Bushings and Hubs
- ▶ Sprockets
- ▶ Pulleys
- ▶ Smart tools

SPA Section

Belt marking	Pitch length	Designation	Belt marking	Pitch length	Designation
	mm			mm	
SPA732	732	PHG SPA732	SPA1682	1682	PHG SPA1682
SPA757	757	PHG SPA757	SPA1700	1700	PHG SPA1700
SPA775	775	PHG SPA775	SPA1707	1707	PHG SPA1707
SPA782	782	PHG SPA782	SPA1732	1732	PHG SPA1732
SPA800	800	PHG SPA800	SPA1750	1750	PHG SPA1750
SPA807	807	PHG SPA807	SPA1757	1757	PHG SPA1757
SPA832	832	PHG SPA832	SPA1782	1782	PHG SPA1782
SPA850	850	PHG SPA850	SPA1800	1800	PHG SPA1800
SPA857	857	PHG SPA857	SPA1807	1807	PHG SPA1807
SPA882	882	PHG SPA882	SPA1820	1820	PHG SPA1820
SPA900	900	PHG SPA900	SPA1832	1832	PHG SPA1832
SPA907	907	PHG SPA907	SPA1850	1850	PHG SPA1850
SPA925	925	PHG SPA925	SPA1857	1857	PHG SPA1857
SPA932	932	PHG SPA932	SPA1882	1882	PHG SPA1882
SPA950	950	PHG SPA950	SPA1900	1900	PHG SPA1900
SPA957	957	PHG SPA957	SPA1907	1907	PHG SPA1907
SPA969	969	PHG SPA969	SPA1932	1932	PHG SPA1932
SPA975	975	PHG SPA975	SPA1950	1950	PHG SPA1950
SPA982	982	PHG SPA982	SPA1957	1957	PHG SPA1957
SPA1000	1000	PHG SPA1000	SPA1982	1982	PHG SPA1982
SPA1007	1007	PHG SPA1007	SPA2000	2000	PHG SPA2000
SPA1030	1030	PHG SPA1030	SPA2032	2032	PHG SPA2032
SPA1032	1032	PHG SPA1032	SPA2057	2057	PHG SPA2057
SPA1055	1055	PHG SPA1055	SPA2060	2060	PHG SPA2060
SPA1060	1060	PHG SPA1060	SPA2082	2082	PHG SPA2082
SPA1082	1082	PHG SPA1082	SPA2120	2120	PHG SPA2120
SPA1090	1090	PHG SPA1090	SPA2132	2132	PHG SPA2132
SPA1107	1107	PHG SPA1107	SPA2160	2160	PHG SPA2160
SPA1120	1120	PHG SPA1120	SPA2182	2182	PHG SPA2182
SPA1132	1132	PHG SPA1132	SPA2207	2207	PHG SPA2207
SPA1150	1150	PHG SPA1150	SPA2232	2232	PHG SPA2232
SPA1157	1157	PHG SPA1157	SPA2240	2240	PHG SPA2240
SPA1180	1180	PHG SPA1180	SPA2282	2282	PHG SPA2282
SPA1190	1190	PHG SPA1190	SPA2300	2300	PHG SPA2300
SPA1200	1200	PHG SPA1200	SPA2307	2307	PHG SPA2307
SPA1207	1207	PHG SPA1207	SPA2332	2332	PHG SPA2332
SPA1220	1220	PHG SPA1220	SPA2360	2360	PHG SPA2360
SPA1232	1232	PHG SPA1232	SPA2382	2382	PHG SPA2382
SPA1250	1250	PHG SPA1250	SPA2430	2430	PHG SPA2430
SPA1257	1257	PHG SPA1257	SPA2432	2432	PHG SPA2432
SPA1272	1272	PHG SPA1272	SPA2482	2482	PHG SPA2482
SPA1282	1282	PHG SPA1282	SPA2500	2500	PHG SPA2500
SPA1300	1300	PHG SPA1300	SPA2532	2532	PHG SPA2532
SPA1307	1307	PHG SPA1307	SPA2582	2582	PHG SPA2582
SPA1320	1320	PHG SPA1320	SPA2607	2607	PHG SPA2607
SPA1332	1332	PHG SPA1332	SPA2632	2632	PHG SPA2632
SPA1357	1357	PHG SPA1357	SPA2650	2650	PHG SPA2650
SPA1360	1360	PHG SPA1360	SPA2682	2682	PHG SPA2682
SPA1367	1367	PHG SPA1367	SPA2732	2732	PHG SPA2732
SPA1382	1382	PHG SPA1382	SPA2782	2782	PHG SPA2782
SPA1400	1400	PHG SPA1400	SPA2800	2800	PHG SPA2800
SPA1407	1407	PHG SPA1407	SPA2832	2832	PHG SPA2832
SPA1415	1415	PHG SPA1415	SPA2847	2847	PHG SPA2847
SPA1420	1420	PHG SPA1420	SPA2882	2882	PHG SPA2882
SPA1432	1432	PHG SPA1432	SPA2900	2900	PHG SPA2900
SPA1450	1450	PHG SPA1450	SPA2932	2932	PHG SPA2932
SPA1457	1457	PHG SPA1457	SPA2982	2982	PHG SPA2982
SPA1482	1482	PHG SPA1482	SPA3000	3000	PHG SPA3000
SPA1490	1490	PHG SPA1490	SPA3032	3032	PHG SPA3032
SPA1500	1500	PHG SPA1500	SPA3082	3082	PHG SPA3082
SPA1507	1507	PHG SPA1507	SPA3150	3150	PHG SPA3150
SPA1532	1532	PHG SPA1532	SPA3182	3182	PHG SPA3182
SPA1550	1550	PHG SPA1550	SPA3282	3282	PHG SPA3282
SPA1557	1557	PHG SPA1557	SPA3350	3350	PHG SPA3350
SPA1582	1582	PHG SPA1582	SPA3382	3382	PHG SPA3382
SPA1600	1600	PHG SPA1600	SPA3550	3550	PHG SPA3550
SPA1607	1607	PHG SPA1607	SPA3750	3750	PHG SPA3750
SPA1632	1632	PHG SPA1632	SPA4000	4000	PHG SPA4000
SPA1650	1650	PHG SPA1650	SPA4250	4250	PHG SPA4250
SPA1657	1657	PHG SPA1657	SPA4500	4500	PHG SPA4500

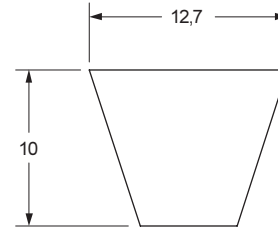

Non-standard lengths are also available.



Wrapped wedge belts

SPB



SPB Section

Belt marking	Pitch length	Designation	Belt marking	Pitch length	Designation
	mm			mm	
SPB1250	1250	PHG SPB1250	SPB2800	2800	PHG SPB2800
SPB1260	1260	PHG SPB1260	SPB2840	2840	PHG SPB2840
SPB1270	1270	PHG SPB1270	SPB2900	2900	PHG SPB2900
SPB1280	1280	PHG SPB1280	SPB2990	2990	PHG SPB2990
SPB1320	1320	PHG SPB1320	SPB3000	3000	PHG SPB3000
SPB1340	1340	PHG SPB1340	SPB3070	3070	PHG SPB3070
SPB1400	1400	PHG SPB1400	SPB3150	3150	PHG SPB3150
SPB1410	1410	PHG SPB1410	SPB3250	3250	PHG SPB3250
SPB1450	1450	PHG SPB1450	SPB3350	3350	PHG SPB3350
SPB1465	1465	PHG SPB1465	SPB3450	3450	PHG SPB3450
SPB1500	1500	PHG SPB1500	SPB3550	3550	PHG SPB3550
SPB1510	1510	PHG SPB1510	SPB3650	3650	PHG SPB3650
SPB1525	1525	PHG SPB1525	SPB3750	3750	PHG SPB3750
SPB1590	1590	PHG SPB1590	SPB3800	3800	PHG SPB3800
SPB1600	1600	PHG SPB1600	SPB3870	3870	PHG SPB3870
SPB1650	1650	PHG SPB1650	SPB4000	4000	PHG SPB4000
SPB1690	1690	PHG SPB1690	SPB4060	4060	PHG SPB4060
SPB1700	1700	PHG SPB1700	SPB4120	4120	PHG SPB4120
SPB1720	1720	PHG SPB1720	SPB4250	4250	PHG SPB4250
SPB1750	1750	PHG SPB1750	SPB4310	4310	PHG SPB4310
SPB1800	1800	PHG SPB1800	SPB4500	4500	PHG SPB4500
SPB1850	1850	PHG SPB1850	SPB4560	4560	PHG SPB4560
SPB1900	1900	PHG SPB1900	SPB4620	4620	PHG SPB4620
SPB2000	2000	PHG SPB2000	SPB4750	4750	PHG SPB4750
SPB2020	2020	PHG SPB2020	SPB4820	4820	PHG SPB4820
SPB2060	2060	PHG SPB2060	SPB5000	5000	PHG SPB5000
SPB2120	2120	PHG SPB2120	SPB5070	5070	PHG SPB5070
SPB2150	2150	PHG SPB2150	SPB5300	5300	PHG SPB5300
SPB2180	2180	PHG SPB2180	SPB5380	5380	PHG SPB5380
SPB2240	2240	PHG SPB2240	SPB5500	5500	PHG SPB5500
SPB2280	2280	PHG SPB2280	SPB5600	5600	PHG SPB5600
SPB2360	2360	PHG SPB2360	SPB5680	5680	PHG SPB5680
SPB2410	2410	PHG SPB2410	SPB6000	6000	PHG SPB6000
SPB2430	2430	PHG SPB2430	SPB6300	6300	PHG SPB6300
SPB2500	2500	PHG SPB2500	SPB6340	6340	PHG SPB6340
SPB2530	2530	PHG SPB2530	SPB6700	6700	PHG SPB6700
SPB2580	2580	PHG SPB2580	SPB7100	7100	PHG SPB7100
SPB2600	2600	PHG SPB2600	SPB7500	7500	PHG SPB7500
SPB2650	2650	PHG SPB2650	SPB8000	8000	PHG SPB8000
SPB2680	2680	PHG SPB2680	-	-	-
SPB2700	2700	PHG SPB2700	-	-	-

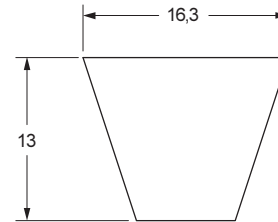

Non-standard lengths are also available.



Wrapped wedge belts

SPC

- ▶ Belts
- ▶ Chains
- ▶ Couplings
- ▶ Bushings and Hubs
- ▶ Sprockets
- ▶ Pulleys
- ▶ Smart tools

SPC Section

Belt marking	Pitch length	Designation	Belt marking	Pitch length	Designation
	mm			mm	
SPC1700	1700	PHG SPC1700	SPC5000	5000	PHG SPC5000
SPC2000	2000	PHG SPC2000	SPC5300	5300	PHG SPC5300
SPC2120	2120	PHG SPC2120	SPC5600	5600	PHG SPC5600
SPC2240	2240	PHG SPC2240	SPC6000	6000	PHG SPC6000
SPC2360	2360	PHG SPC2360	SPC6300	6300	PHG SPC6300
SPC2500	2500	PHG SPC2500	SPC6700	6700	PHG SPC6700
SPC2650	2650	PHG SPC2650	SPC7100	7100	PHG SPC7100
SPC2800	2800	PHG SPC2800	SPC7500	7500	PHG SPC7500
SPC3000	3000	PHG SPC3000	SPC8000	8000	PHG SPC8000
SPC3150	3150	PHG SPC3150	SPC8500	8500	PHG SPC8500
SPC3350	3350	PHG SPC3350	SPC9000	9000	PHG SPC9000
SPC3550	3550	PHG SPC3550	SPC9500	9500	PHG SPC9500
SPC3750	3750	PHG SPC3750	SPC10000	10000	PHG SPC10000
SPC4000	4000	PHG SPC4000	SPC10600	10600	PHG SPC10600
SPC4250	4250	PHG SPC4250	SPC11200	11200	PHG SPC11200
SPC4500	4500	PHG SPC4500	SPC11800	11800	PHG SPC11800
SPC4750	4750	PHG SPC4750	SPC12500	12500	PHG SPC12500

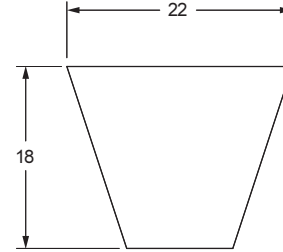

Non-standard lengths are also available.



Wrapped classical belts

10/Z



10/Z Section

Pitch length		Inside length		Designation	Pitch length		Inside length		Designation
mm		mm	inches		mm	mm	inches		
390		368	14,50	PHG Z14.5	940	927	36,50	PHG Z36.5	
395		381	15,00	PHG Z15	950	940	37,00	PHG Z37	
405		387	15,25	PHG Z15.25	965	953	37,50	PHG Z37.5	
410		394	15,50	PHG Z15.5	975	959	37,75	PHG Z37.75	
420		406	16,00	PHG Z16	980	965	38,00	PHG Z38	
440		419	16,50	PHG Z16.5	990	978	38,50	PHG Z38.5	
445		432	17,00	PHG Z17	1005	984	38,75	PHG Z38.75	
465		445	17,50	PHG Z17.5	1015	991	39,00	PHG Z39	
470		457	18,00	PHG Z18	1025	1003	39,50	PHG Z39.5	
480		470	18,50	PHG Z18.5	1035	1016	40,00	PHG Z40	
495		483	19,00	PHG Z19	1045	1029	40,50	PHG Z40.5	
510		495	19,50	PHG Z19.5	1050	1035	40,75	PHG Z40.75	
520		508	20,00	PHG Z20	1055	1041	41,00	PHG Z41	
530		521	20,50	PHG Z20.5	1075	1054	41,50	PHG Z41.5	
545		533	21,00	PHG Z21	1080	1067	42,00	PHG Z42	
555		540	21,25	PHG Z21.25	1105	1092	43,00	PHG Z43	
570		559	22,00	PHG Z22	1125	1105	43,50	PHG Z43.5	
585		565	22,25	PHG Z22.25	1130	1118	44,00	PHG Z44	
590		572	22,50	PHG Z22.5	1155	1143	45,00	PHG Z45	
600		584	23,00	PHG Z23	1170	1149	45,25	PHG Z45.25	
610		597	23,50	PHG Z23.5	1175	1156	45,50	PHG Z45.5	
620		610	24,00	PHG Z24	1190	1168	46,00	PHG Z46	
630		622	24,50	PHG Z24.5	1200	1181	46,50	PHG Z46.5	
650		635	25,00	PHG Z25	1205	1194	47,00	PHG Z47	
660		648	25,50	PHG Z25.5	1230	1207	47,50	PHG Z47.5	
675		654	25,75	PHG Z25.75	1240	1219	48,00	PHG Z48	
680		660	26,00	PHG Z26	1255	1232	48,50	PHG Z48.5	
685		667	26,25	PHG Z26.25	1270	1245	49,00	PHG Z49	
690		673	26,50	PHG Z26.5	1290	1270	50,00	PHG Z50	
700		686	27,00	PHG Z27	1330	1295	51,00	PHG Z51	
710		692	27,25	PHG Z27.25	1335	1314	51,75	PHG Z51.75	
715		699	27,50	PHG Z27.5	1340	1321	52,00	PHG Z52	
725		711	28,00	PHG Z28	1380	1346	53,00	PHG Z53	
740		724	28,50	PHG Z28.5	1390	1372	54,00	PHG Z54	
750		737	29,00	PHG Z29	1420	1397	55,00	PHG Z55	
770		749	29,50	PHG Z29.5	1440	1422	56,00	PHG Z56	
775		756	29,75	PHG Z29.75	1465	1448	57,00	PHG Z57	
780		762	30,00	PHG Z30	1515	1499	59,00	PHG Z59	
795		775	30,50	PHG Z30.5	1540	1524	60,00	PHG Z60	
800		787	31,00	PHG Z31	1570	1549	61,00	PHG Z61	
820		800	31,50	PHG Z31.5	1595	1575	62,00	PHG Z62	
840		813	32,00	PHG Z32	1620	1600	63,00	PHG Z63	
845		826	32,50	PHG Z32.5	1645	1626	64,00	PHG Z64	
850		838	33,00	PHG Z33	1670	1651	65,00	PHG Z65	
860		851	33,50	PHG Z33.5	1695	1676	66,00	PHG Z66	
875		864	34,00	PHG Z34	1720	1702	67,00	PHG Z67	
890		876	34,50	PHG Z34.5	1750	1727	68,00	PHG Z68	
900		889	35,00	PHG Z35	1770	1753	69,00	PHG Z69	
915		895	35,25	PHG Z35.25	1820	1803	71,00	PHG Z71	
920		902	35,50	PHG Z35.5	1930	1905	75,00	PHG Z75	
925		908	35,75	PHG Z35.75	2000	1981	78,00	PHG Z78	
930		914	36,00	PHG Z36	2025	2007	79,00	PHG Z79	

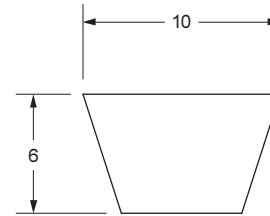

Non-standard lengths are also available.



Wrapped classical belts

13/A

- ▶ Belts
- ▶ Chains
- ▶ Couplings
- ▶ Bushings and Hubs
- ▶ Sprockets
- ▶ Pulleys
- ▶ Smart tools

13/A Section

Pitch length			Inside length			Designation	Pitch length			Inside length			Designation
mm	mm	inches	mm	mm	inches		mm	mm	inches	mm	mm	inches	
436	406	16,0	PHG A16	1580	1549	61,0	PHG A61						
487	457	18,0	PHG A18	1610	1575	62,0	PHG A62						
510	483	19,0	PHG A19	1640	1600	63,0	PHG A63						
540	508	20,0	PHG A20	1660	1626	64,0	PHG A64						
570	533	21,0	PHG A21	1690	1651	65,0	PHG A65						
590	559	22,0	PHG A22	1710	1676	66,0	PHG A66						
620	584	23,0	PHG A23	1740	1702	67,0	PHG A67						
630	597	23,5	PHG A23.5	1750	1715	67,5	PHG A67.5						
640	610	24,0	PHG A24	1760	1727	68,0	PHG A68						
670	635	25,0	PHG A25	1790	1753	69,0	PHG A69						
700	660	26,0	PHG A26	1810	1778	70,0	PHG A70						
710	673	26,5	PHG A26.5	1840	1803	71,0	PHG A71						
720	686	27,0	PHG A27	1860	1829	72,0	PHG A72						
730	699	27,5	PHG A27.5	1890	1854	73,0	PHG A73						
740	711	28,0	PHG A28	1920	1880	74,0	PHG A74						
770	737	29,0	PHG A29	1940	1905	75,0	PHG A75						
780	749	29,5	PHG A29.5	1960	1930	76,0	PHG A76						
790	762	30,0	PHG A30	1990	1956	77,0	PHG A77						
800	775	30,5	PHG A30.5	2020	1981	78,0	PHG A78						
810	781	30,8	PHG A30.75	2050	2007	79,0	PHG A79						
817	787	31,0	PHG A31	2070	2032	80,0	PHG A80						
830	800	31,5	PHG A31.5	2090	2057	81,0	PHG A81						
850	813	32,0	PHG A32	2120	2083	82,0	PHG A82						
860	826	32,5	PHG A32.5	2140	2108	83,0	PHG A83						
870	838	33,0	PHG A33	2150	2121	83,5	PHG A83.5						
880	851	33,5	PHG A33.5	2170	2134	84,0	PHG A84						
890	864	34,0	PHG A34	2185	2146	84,5	PHG A84.5						
900	876	34,5	PHG A34.5	2200	2159	85,0	PHG A85						
920	889	35,0	PHG A35	2220	2184	86,0	PHG A86						
930	902	35,5	PHG A35.5	2230	2197	86,5	PHG A86.5						
950	914	36,0	PHG A36	2240	2210	87,0	PHG A87						
955	921	36,3	PHG A36.25	2270	2235	88,0	PHG A88						
970	940	37,0	PHG A37	2300	2261	89,0	PHG A89						
980	953	37,5	PHG A37.5	2320	2286	90,0	PHG A90						
990	965	38,0	PHG A38	2350	2311	91,0	PHG A91						
1010	978	38,5	PHG A38.5	2370	2337	92,0	PHG A92						
1020	991	39,0	PHG A39	2400	2362	93,0	PHG A93						
1050	1016	40,0	PHG A40	2420	2388	94,0	PHG A94						
1060	1029	40,5	PHG A40.5	2450	2413	95,0	PHG A95						
1070	1041	41,0	PHG A41	2480	2438	96,0	PHG A96						
1085	1054	41,5	PHG A41.5	2500	2464	97,0	PHG A97						
1100	1067	42,0	PHG A42	2520	2489	98,0	PHG A98						
1110	1080	42,5	PHG A42.5	2550	2515	99,0	PHG A99						
1130	1092	43,0	PHG A43	2570	2540	100,0	PHG A100						
1150	1118	44,0	PHG A44	2630	2591	102,0	PHG A102						
1180	1143	45,0	PHG A45	2680	2642	104,0	PHG A104						
1185	1149	45,3	PHG A45.25	2700	2667	105,0	PHG A105						
1200	1168	46,0	PHG A46	2750	2718	107,0	PHG A107						
1215	1181	46,5	PHG A46.5	2780	2743	108,0	PHG A108						
1230	1194	47,0	PHG A47	2830	2794	110,0	PHG A110						
1240	1207	47,5	PHG A47.5	2880	2845	112,0	PHG A112						
1250	1219	48,0	PHG A48	2930	2896	114,0	PHG A114						
1265	1232	48,5	PHG A48.5	2980	2946	116,0	PHG A116						
1280	1245	49,0	PHG A49	3030	2997	118,0	PHG A118						
1300	1270	50,0	PHG A50	3080	3048	120,0	PHG A120						
1315	1283	50,5	PHG A50.5	3190	3150	124,0	PHG A124						
1330	1295	51,0	PHG A51	3290	3251	128,0	PHG A128						
1360	1321	52,0	PHG A52	3340	3302	130,0	PHG A130						
1380	1346	53,0	PHG A53	3390	3353	132,0	PHG A132						
1410	1372	54,0	PHG A54	3490	3454	136,0	PHG A136						
1430	1397	55,0	PHG A55	3590	3556	140,0	PHG A140						
1460	1422	56,0	PHG A56	3690	3658	144,0	PHG A144						
1480	1448	57,0	PHG A57	3800	3759	148,0	PHG A148						
1510	1473	58,0	PHG A58	3840	3810	150,0	PHG A150						
1530	1499	59,0	PHG A59	4043	4013	158,0	PHG A158						
1550	1524	60,0	PHG A60	4424	4394	173,0	PHG A173						
-	-	-	-	4780	4750	187,0	PHG A187						

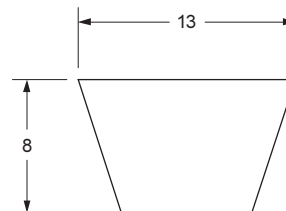

Non-standard lengths are also available.



Wrapped classical belts

17/B



17/B Section

Pitch length			Inside length			Designation	Pitch length			Inside length			Designation	Pitch length			Inside length			Designation
mm	mm	inches	mm	mm	inches		mm	mm	inches	mm	mm	inches		mm	mm	inches	mm	mm	inches	
624	584	23,00	PHG B23	1490	1448	57,00	PHG B57	2872	2832	111,50	PHG B111.5									
650	610	24,00	PHG B24	1510	1473	58,00	PHG B58	2890	2845	112,00	PHG B112									
675	635	25,00	PHG B25	1540	1499	59,00	PHG B59	2940	2896	114,00	PHG B114									
700	660	26,00	PHG B26	1560	1524	60,00	PHG B60	2960	2921	115,00	PHG B115									
715	673	26,50	PHG B26.5	1590	1549	61,00	PHG B61	2990	2946	116,00	PHG B116									
730	686	27,00	PHG B27	1620	1575	62,00	PHG B62	3040	2997	118,00	PHG B118									
750	711	28,00	PHG B28	1640	1600	63,00	PHG B63	3090	3048	120,00	PHG B120									
760	724	28,50	PHG B28.5	1655	1613	63,50	PHG B63.5	3140	3099	122,00	PHG B122									
770	737	29,00	PHG B29	1670	1626	64,00	PHG B64	3200	3150	124,00	PHG B124									
785	749	29,50	PHG B29.5	1690	1651	65,00	PHG B65	3240	3200	126,00	PHG B126									
800	762	30,00	PHG B30	1720	1676	66,00	PHG B66	3290	3251	128,00	PHG B128									
830	787	31,00	PHG B31	1740	1702	67,00	PHG B67	3350	3302	130,00	PHG B130									
845	800	31,50	PHG B31.5	1760	1727	68,00	PHG B68	3400	3353	132,00	PHG B132									
860	813	32,00	PHG B32	1800	1753	69,00	PHG B69	3450	3404	134,00	PHG B134									
863	819	32,25	PHG B32.25	1810	1765	69,50	PHG B69.5	3500	3454	136,00	PHG B136									
866	826	32,50	PHG B32.5	1820	1778	70,00	PHG B70	3550	3505	138,00	PHG B138									
880	838	33,00	PHG B33	1850	1803	71,00	PHG B71	3600	3556	140,00	PHG B140									
895	851	33,50	PHG B33.5	1870	1829	72,00	PHG B72	3650	3607	142,00	PHG B142									
900	857	33,75	PHG B33.75	1900	1854	73,00	PHG B73	3700	3658	144,00	PHG B144									
910	864	34,00	PHG B34	1920	1880	74,00	PHG B74	3750	3708	146,00	PHG B146									
920	876	34,50	PHG B34.5	1950	1905	75,00	PHG B75	3800	3759	148,00	PHG B148									
930	889	35,00	PHG B35	1970	1930	76,00	PHG B76	3850	3810	150,00	PHG B150									
945	902	35,50	PHG B35.5	2000	1956	77,00	PHG B77	3870	3835	151,00	PHG B151									
950	908	35,75	PHG B35.75	2020	1981	78,00	PHG B78	3900	3861	152,00	PHG B152									
960	914	36,00	PHG B36	2050	2007	79,00	PHG B79	3950	3912	154,00	PHG B154									
965	921	36,25	PHG B36.25	2070	2032	80,00	PHG B80	4010	3962	156,00	PHG B156									
970	927	36,50	PHG B36.5	2100	2057	81,00	PHG B81	4060	4013	158,00	PHG B158									
980	940	37,00	PHG B37	2130	2083	82,00	PHG B82	4110	4064	160,00	PHG B160									
990	953	37,50	PHG B37.5	2150	2108	83,00	PHG B83	4160	4115	162,00	PHG B162									
1000	965	38,00	PHG B38	2165	2121	83,50	PHG B83.5	4200	4166	164,00	PHG B164									
1020	978	38,50	PHG B38.5	2180	2134	84,00	PHG B84	4230	4191	165,00	PHG B165									
1030	991	39,00	PHG B39	2200	2159	85,00	PHG B85	4280	4242	167,00	PHG B167									
1045	1003	39,50	PHG B39.5	2230	2184	86,00	PHG B86	4360	4318	170,00	PHG B170									
1060	1016	40,00	PHG B40	2250	2210	87,00	PHG B87	4430	4394	173,00	PHG B173									
1070	1029	40,50	PHG B40.5	2280	2235	88,00	PHG B88	4490	4445	175,00	PHG B175									
1080	1041	41,00	PHG B41	2300	2261	89,00	PHG B89	4540	4496	177,00	PHG B177									
1090	1054	41,50	PHG B41.5	2330	2286	90,00	PHG B90	4610	4572	180,00	PHG B180									
1100	1067	42,00	PHG B42	2350	2311	91,00	PHG B91	4740	4699	185,00	PHG B185									
1115	1080	42,50	PHG B42.5	2380	2337	92,00	PHG B92	4800	4750	187,00	PHG B187									
1130	1092	43,00	PHG B43	2400	2362	93,00	PHG B93	5000	4953	195,00	PHG B195									
1140	1099	43,25	PHG B43.25	2420	2388	94,00	PHG B94	5044	5004	197,00	PHG B197									
1160	1118	44,00	PHG B44	2435	2400	94,50	PHG B94.5	5220	5182	204,00	PHG B204									
1180	1143	45,00	PHG B45	2450	2413	95,00	PHG B95	5340	5283	208,00	PHG B208									
1195	1156	45,50	PHG B45.5	2480	2438	96,00	PHG B96	5370	5334	210,00	PHG B210									
1210	1168	46,00	PHG B46	2490	2451	96,50	PHG B96.5	5630	5588	220,00	PHG B220									
1225	1181	46,50	PHG B46.5	2500	2464	97,00	PHG B97	5760	5715	225,00	PHG B225									
1240	1194	47,00	PHG B47	2530	2489	98,00	PHG B98	6040	5994	236,00	PHG B236									
1260	1219	48,00	PHG B48	2560	2515	99,00	PHG B99	6140	6096	240,00	PHG B240									
1290	1245	49,00	PHG B49	2580	2540	100,00	PHG B100	6340	6299	248,00	PHG B248									
1310	1270	50,00	PHG B50	2610	2565	101,00	PHG B101	6750	6706	264,00	PHG B264									
1340	1295	51,00	PHG B51	2630	2591	102,00	PHG B102	6900	6858	270,00	PHG B270									
1370	1321	52,00	PHG B52	2660	2616	103,00	PHG B103	7025	6985	275,00	PHG B275									
1380	1334	52,50	PHG B52.5	2680	2642	104,00	PHG B104	7050	7010	276,00	PHG B276									
1390	1346	53,00	PHG B53	2700	2667	105,00	PHG B105	7150	7112	280,00	PHG B280									
1400	1359	53,50	PHG B53.5	2740	2692	106,00	PHG B106	7660	7620	300,00	PHG B300									
1410	1372	54,00	PHG B54	2760	2718	107,00	PHG B107	8040	8001	315,00	PHG B315									
1440	1397	55,00	PHG B55	2790	2743	108,00	PHG B108	-	-	-	-									
1460	1422	56,00	PHG B56	2840	2794	110,00	PHG B110	-	-	-	-									

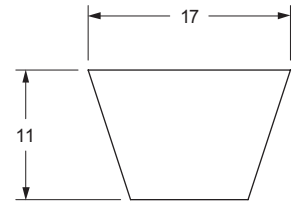

Non-standard lengths are also available.



Wrapped classical belts

22/C

- ▶ Belts
- ▶ Chains
- ▶ Couplings
- ▶ Bushings and Hubs
- ▶ Sprockets
- ▶ Pulleys
- ▶ Smart tools

22/C Section

Pitch length			Designation	Pitch length			Designation
mm	mm	inches		mm	mm	inches	
1126	1067	42,00	PHG C42	2700	2642	104,00	PHG C104
1150	1092	43,00	PHG C43	2720	2667	105,00	PHG C105
1250	1194	47,00	PHG C47	2740	2692	106,00	PHG C106
1280	1219	48,00	PHG C48	2800	2743	108,00	PHG C108
1300	1245	49,00	PHG C49	2850	2794	110,00	PHG C110
1325	1270	50,00	PHG C50	2900	2845	112,00	PHG C112
1349	1289	50,75	PHG C50.75	2950	2896	114,00	PHG C114
1350	1295	51,00	PHG C51	2980	2921	115,00	PHG C115
1370	1321	52,00	PHG C52	2990	2934	115,50	PHG C115.5
1400	1346	53,00	PHG C53	3000	2946	116,00	PHG C116
1430	1372	54,00	PHG C54	3050	2997	118,00	PHG C118
1450	1397	55,00	PHG C55	3100	3048	120,00	PHG C120
1480	1422	56,00	PHG C56	3160	3099	122,00	PHG C122
1500	1448	57,00	PHG C57	3210	3150	124,00	PHG C124
1530	1473	58,00	PHG C58	3270	3200	126,00	PHG C126
1560	1499	59,00	PHG C59	3310	3251	128,00	PHG C128
1580	1524	60,00	PHG C60	3360	3302	130,00	PHG C130
1610	1549	61,00	PHG C61	3410	3353	132,00	PHG C132
1630	1575	62,00	PHG C62	3460	3404	134,00	PHG C134
1650	1600	63,00	PHG C63	3520	3454	136,00	PHG C136
1700	1651	65,00	PHG C65	3560	3505	138,00	PHG C138
1730	1676	66,00	PHG C66	3610	3556	140,00	PHG C140
1760	1702	67,00	PHG C67	3660	3607	142,00	PHG C142
1780	1727	68,00	PHG C68	3710	3658	144,00	PHG C144
1810	1753	69,00	PHG C69	3760	3708	146,00	PHG C146
1830	1778	70,00	PHG C70	3820	3759	148,00	PHG C148
1860	1803	71,00	PHG C71	3870	3810	150,00	PHG C150
1880	1829	72,00	PHG C72	3920	3861	152,00	PHG C152
1910	1854	73,00	PHG C73	4060	4013	158,00	PHG C158
1930	1880	74,00	PHG C74	4170	4115	162,00	PHG C162
1940	1892	74,50	PHG C74.5	4280	4216	166,00	PHG C166
1950	1905	75,00	PHG C75	4300	4242	167,00	PHG C167
1990	1930	76,00	PHG C76	4320	4267	168,00	PHG C168
2000	1943	76,50	PHG C76.5	4450	4394	173,00	PHG C173
2010	1956	77,00	PHG C77	4500	4445	175,00	PHG C175
2040	1981	78,00	PHG C78	4560	4496	177,00	PHG C177
2060	2007	79,00	PHG C79	4630	4572	180,00	PHG C180
2090	2032	80,00	PHG C80	4810	4750	187,00	PHG C187
2110	2057	81,00	PHG C81	4880	4826	190,00	PHG C190
2140	2083	82,00	PHG C82	5010	4953	195,00	PHG C195
2160	2108	83,00	PHG C83	5060	5004	197,00	PHG C197
2175	2121	83,50	PHG C83.5	5240	5182	204,00	PHG C204
2190	2134	84,00	PHG C84	5340	5283	208,00	PHG C208
2205	2146	84,50	PHG C84.5	5380	5334	210,00	PHG C210
2220	2159	85,00	PHG C85	5640	5588	220,00	PHG C220
2240	2184	86,00	PHG C86	5770	5715	225,00	PHG C225
2270	2210	87,00	PHG C87	6050	5994	236,00	PHG C236
2290	2235	88,00	PHG C88	6100	6045	238,00	PHG C238
2320	2261	89,00	PHG C89	6150	6096	240,00	PHG C240
2340	2286	90,00	PHG C90	6360	6299	248,00	PHG C248
2390	2337	92,00	PHG C92	6535	6477	255,00	PHG C255
2420	2362	93,00	PHG C93	6760	6706	264,00	PHG C264
2440	2388	94,00	PHG C94	6910	6858	270,00	PHG C270
2470	2413	95,00	PHG C95	7170	7112	280,00	PHG C280
2490	2438	96,00	PHG C96	7550	7493	295,00	PHG C295
2505	2451	96,50	PHG C96.5	7680	7620	300,00	PHG C300
2520	2464	97,00	PHG C97	8060	8001	315,00	PHG C315
2550	2489	98,00	PHG C98	8390	8331	328,00	PHG C328
2570	2515	99,00	PHG C99	8440	8382	330,00	PHG C330
2600	2540	100,00	PHG C100	9200	9144	360,00	PHG C360
2620	2565	101,00	PHG C101	9970	9906	390,00	PHG C390
2650	2591	102,00	PHG C102	10670	10617	418,00	PHG C418

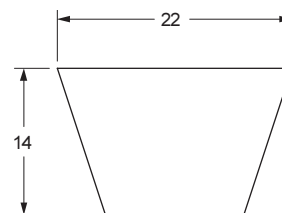

Non-standard lengths are also available.



Wrapped classical belts

32/D, 38/E



32/D Section

Pitch length			Inside length			Designation	Pitch length			Inside length			Designation
mm	mm	inches	mm	mm	inches		mm	mm	inches	mm	mm	inches	
2560	2489	98	PHG D98	5400	5334	210	PHG D210						
2720	2642	104	PHG D104	5670	5588	220	PHG D220						
2740	2667	105	PHG D105	5790	5715	225	PHG D225						
2870	2794	110	PHG D110	6070	5994	236	PHG D236						
3080	2997	118	PHG D118	6170	6096	240	PHG D240						
3130	3048	120	PHG D120	6380	6299	248	PHG D248						
3225	3150	124	PHG D124	6425	6350	250	PHG D250						
3330	3251	128	PHG D128	6560	6477	255	PHG D255						
3430	3353	132	PHG D132	6780	6706	264	PHG D264						
3530	3454	136	PHG D136	6910	6833	269	PHG D269						
3555	3480	137	PHG D137	6940	6858	270	PHG D270						
3640	3556	140	PHG D140	7190	7112	280	PHG D280						
3730	3658	144	PHG D144	7320	7239	285	PHG D285						
3830	3759	148	PHG D148	7650	7569	298	PHG D298						
4080	4013	158	PHG D158	7700	7620	300	PHG D300						
4190	4115	162	PHG D162	8080	8001	315	PHG D315						
4320	4242	167	PHG D167	8410	8331	328	PHG D328						
4395	4318	170	PHG D170	8460	8382	330	PHG D330						
4470	4394	173	PHG D173	9070	8992	354	PHG D354						
4580	4496	177	PHG D177	9220	9144	360	PHG D360						
4650	4572	180	PHG D180	9580	9500	374	PHG D374						
4830	4750	187	PHG D187	9980	9906	390	PHG D390						
5030	4953	195	PHG D195	10085	10008	394	PHG D394						
5080	5004	197	PHG D197	10700	10617	418	PHG D418						
5360	5283	208	PHG D208	12190	12116	477	PHG D477						

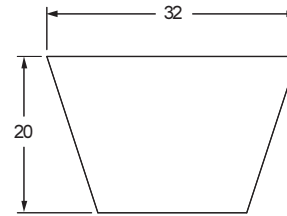

Non-standard lengths are also available.

38/E Section

Pitch length			Inside length			Designation	Pitch length			Inside length			Designation
mm	mm	inches	mm	mm	inches		mm	mm	inches	mm	mm	inches	
3076	2997	118	PHG E118	8075	8001	315	PHG E315						
4091	4013	158	PHG E158	8405	8331	328	PHG E328						
4979	4902	193	PHG E193	8430	8357	329	PHG E329						
5030	4953	195	PHG E195	8455	8382	330	PHG E330						
5081	5004	197	PHG E197	8709	8636	340	PHG E340						
5537	5461	215	PHG E215	9065	8992	354	PHG E354						
5664	5588	220	PHG E220	9166	9093	358	PHG E358						
6070	5994	236	PHG E236	9217	9144	360	PHG E360						
6121	6045	238	PHG E238	10080	10008	394	PHG E394						
6172	6096	240	PHG E240	10689	10617	418	PHG E418						
6375	6299	248	PHG E248	10739	10668	420	PHG E420						
6654	6579	259	PHG E259	11247	11176	440	PHG E440						
6806	6731	265	PHG E265	11272	11201	441	PHG E441						
6933	6858	270	PHG E270	11983	11913	469	PHG E469						
7187	7112	280	PHG E280	12262	12192	480	PHG E480						
7567	7493	295	PHG E295	12566	12497	492	PHG E492						
7643	7569	298	PHG E298	13784	13716	540	PHG E540						
7694	7620	300	PHG E300	-	-	-	-						

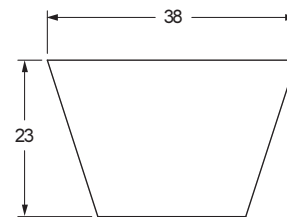

Non-standard lengths are also available.



Wrapped narrow wedge belts

3V, 5V, 8V

- ▶ Belts
- ▶ Chains
- ▶ Couplings
- ▶ Bushings and Hubs
- ▶ Sprockets
- ▶ Pulleys
- ▶ Smart tools

3V/9N Section

Outside length		Designation	Outside length		Designation
mm	inches		mm	inches	
635	25,0	PHG 3V250	1600	63,0	PHG 3V630
673	26,5	PHG 3V265	1702	67,0	PHG 3V670
711	28,0	PHG 3V280	1803	71,0	PHG 3V710
762	30,0	PHG 3V300	1905	75,0	PHG 3V750
800	31,5	PHG 3V315	2032	80,0	PHG 3V800
851	33,5	PHG 3V335	2159	85,0	PHG 3V850
902	35,5	PHG 3V355	2286	90,0	PHG 3V900
953	37,5	PHG 3V375	2413	95,0	PHG 3V950
1016	40,0	PHG 3V400	2540	100,0	PHG 3V1000
1080	42,5	PHG 3V425	2692	106,0	PHG 3V1060
1143	45,0	PHG 3V450	2845	112,0	PHG 3V1120
1207	47,5	PHG 3V475	2997	118,0	PHG 3V1180
1270	50,0	PHG 3V500	3175	125,0	PHG 3V1250
1346	53,0	PHG 3V530	3353	132,0	PHG 3V1320
1422	56,0	PHG 3V560	3556	140,0	PHG 3V1400
1524	60,0	PHG 3V600	-	-	-

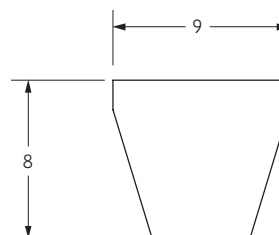

5V/15N Section

Outside length		Designation	Outside length		Designation
mm	inches		mm	inches	
1346	53,0	PHG 5V530	3556	140,0	PHG 5V1400
1422	56,0	PHG 5V560	3810	150,0	PHG 5V1500
1524	60,0	PHG 5V600	4064	160,0	PHG 5V1600
1600	63,0	PHG 5V630	4318	170,0	PHG 5V1700
1702	67,0	PHG 5V670	4572	180,0	PHG 5V1800
1803	71,0	PHG 5V710	4826	190,0	PHG 5V1900
1905	75,0	PHG 5V750	5080	200,0	PHG 5V2000
2032	80,0	PHG 5V800	5385	212,0	PHG 5V2120
2159	85,0	PHG 5V850	5690	224,0	PHG 5V2240
2286	90,0	PHG 5V900	5994	236,0	PHG 5V2360
2413	95,0	PHG 5V950	6350	250,0	PHG 5V2500
2540	100,0	PHG 5V1000	6731	265,0	PHG 5V2650
2692	106,0	PHG 5V1060	7112	280,0	PHG 5V2800
2845	112,0	PHG 5V1120	7620	300,0	PHG 5V3000
2997	118,0	PHG 5V1180	8001	315,0	PHG 5V3150
3175	125,0	PHG 5V1250	8509	335,0	PHG 5V3350
3353	132,0	PHG 5V1320	9017	355,0	PHG 5V3550

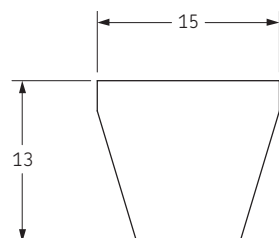

8V/25N Section

Outside length		Designation	Outside length		Designation
mm	inches		mm	inches	
2540	100,0	PHG 8V1000	5994	236,0	PHG 8V2360
2692	106,0	PHG 8V1060	6350	250,0	PHG 8V2500
2845	112,0	PHG 8V1120	6731	265,0	PHG 8V2650
2997	118,0	PHG 8V1180	7112	280,0	PHG 8V2800
3175	125,0	PHG 8V1250	7620	300,0	PHG 8V3000
3353	132,0	PHG 8V1320	8001	315,0	PHG 8V3150
3556	140,0	PHG 8V1400	8509	335,0	PHG 8V3350
3810	150,0	PHG 8V1500	9017	355,0	PHG 8V3550
4064	160,0	PHG 8V1600	9525	375,0	PHG 8V3750
4318	170,0	PHG 8V1700	10160	400,0	PHG 8V4000
4572	180,0	PHG 8V1800	10795	425,0	PHG 8V4250
4826	190,0	PHG 8V1900	11430	450,0	PHG 8V4500
5080	200,0	PHG 8V2000	12065	475,0	PHG 8V4750
5385	212,0	PHG 8V2120	12700	500,0	PHG 8V5000
5690	224,0	PHG 8V2240	-	-	-

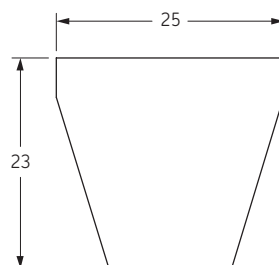

Non-standard lengths are also available.



Cogged raw edge wedge belts

XPZ



XPZ Section Cogged Raw Edge

Belt marking	Pitch length	Designation	Belt marking	Pitch length	Designation
	mm			mm	
XPZ630	630	PHG XPZ630	XPZ1202	1202	PHG XPZ1202
XPZ637	637	PHG XPZ637	XPZ1212	1212	PHG XPZ1212
XPZ662	662	PHG XPZ662	XPZ1237	1237	PHG XPZ1237
XPZ670	670	PHG XPZ670	XPZ1250	1250	PHG XPZ1250
XPZ687	687	PHG XPZ687	XPZ1262	1262	PHG XPZ1262
XPZ710	710	PHG XPZ710	XPZ1270	1270	PHG XPZ1270
XPZ737	737	PHG XPZ737	XPZ1287	1287	PHG XPZ1287
XPZ750	750	PHG XPZ750	XPZ1312	1312	PHG XPZ1312
XPZ760	760	PHG XPZ760	XPZ1320	1320	PHG XPZ1320
XPZ762	762	PHG XPZ762	XPZ1337	1337	PHG XPZ1337
XPZ772	772	PHG XPZ772	XPZ1340	1340	PHG XPZ1340
XPZ787	787	PHG XPZ787	XPZ1362	1362	PHG XPZ1362
XPZ800	800	PHG XPZ800	XPZ1400	1400	PHG XPZ1400
XPZ812	812	PHG XPZ812	XPZ1412	1412	PHG XPZ1412
XPZ837	837	PHG XPZ837	XPZ1420	1420	PHG XPZ1420
XPZ850	850	PHG XPZ850	XPZ1487	1487	PHG XPZ1487
XPZ862	862	PHG XPZ862	XPZ1500	1500	PHG XPZ1500
XPZ875	875	PHG XPZ875	XPZ1512	1512	PHG XPZ1512
XPZ887	887	PHG XPZ887	XPZ1520	1520	PHG XPZ1520
XPZ900	900	PHG XPZ900	XPZ1537	1537	PHG XPZ1537
XPZ912	912	PHG XPZ912	XPZ1587	1587	PHG XPZ1587
XPZ925	925	PHG XPZ925	XPZ1600	1600	PHG XPZ1600
XPZ937	937	PHG XPZ937	XPZ1700	1700	PHG XPZ1700
XPZ950	950	PHG XPZ950	XPZ1800	1800	PHG XPZ1800
XPZ962	962	PHG XPZ962	XPZ1850	1850	PHG XPZ1850
XPZ987	987	PHG XPZ987	XPZ1900	1900	PHG XPZ1900
XPZ1000	1000	PHG XPZ1000	XPZ2000	2000	PHG XPZ2000
XPZ1010	1010	PHG XPZ1010	XPZ2030	2030	PHG XPZ2030
XPZ1012	1012	PHG XPZ1012	XPZ2120	2120	PHG XPZ2120
XPZ1037	1037	PHG XPZ1037	XPZ2240	2240	PHG XPZ2240
XPZ1060	1060	PHG XPZ1060	XPZ2280	2280	PHG XPZ2280
XPZ1077	1077	PHG XPZ1077	XPZ2360	2360	PHG XPZ2360
XPZ1080	1080	PHG XPZ1080	XPZ2410	2410	PHG XPZ2410
XPZ1087	1087	PHG XPZ1087	XPZ2500	2500	PHG XPZ2500
XPZ1112	1112	PHG XPZ1112	XPZ2540	2540	PHG XPZ2540
XPZ1120	1120	PHG XPZ1120	XPZ2650	2650	PHG XPZ2650
XPZ1137	1137	PHG XPZ1137	XPZ2800	2800	PHG XPZ2800
XPZ1140	1140	PHG XPZ1140	XPZ3000	3000	PHG XPZ3000
XPZ1162	1162	PHG XPZ1162	XPZ3150	3150	PHG XPZ3150
XPZ1180	1180	PHG XPZ1180	XPZ3350	3350	PHG XPZ3350
XPZ1187	1187	PHG XPZ1187	XPZ3550	3550	PHG XPZ3550
XPZ1200	1200	PHG XPZ1200	-	-	-

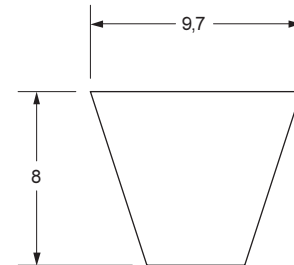

Non-standard lengths are also available.



Cogged raw edge wedge belts

XPA, XPB, XPC

- ▶ Belts
- ▶ Chains
- ▶ Couplings
- ▶ Bushings and Hubs
- ▶ Sprockets
- ▶ Pulleys
- ▶ Smart tools

XPA Section Cogged Raw Edge

Belt marking	Pitch length	Designation	Belt marking	Pitch length	Designation
	mm			mm	
XPA757	757	PHG XPA757	XPA1282	1282	PHG XPA1282
XPA782	782	PHG XPA782	XPA1307	1307	PHG XPA1307
XPA800	800	PHG XPA800	XPA1320	1320	PHG XPA1320
XPA832	832	PHG XPA832	XPA1332	1332	PHG XPA1332
XPA850	850	PHG XPA850	XPA1357	1357	PHG XPA1357
XPA857	857	PHG XPA857	XPA1400	1400	PHG XPA1400
XPA882	882	PHG XPA882	XPA1482	1482	PHG XPA1482
XPA900	900	PHG XPA900	XPA1500	1500	PHG XPA1500
XPA907	907	PHG XPA907	XPA1507	1507	PHG XPA1507
XPA932	932	PHG XPA932	XPA1532	1532	PHG XPA1532
XPA950	950	PHG XPA950	XPA1582	1582	PHG XPA1582
XPA957	957	PHG XPA957	XPA1600	1600	PHG XPA1600
XPA982	982	PHG XPA982	XPA1700	1700	PHG XPA1700
XPA1000	1000	PHG XPA1000	XPA1800	1800	PHG XPA1800
XPA1007	1007	PHG XPA1007	XPA1900	1900	PHG XPA1900
XPA1030	1030	PHG XPA1030	XPA2000	2000	PHG XPA2000
XPA1060	1060	PHG XPA1060	XPA2120	2120	PHG XPA2120
XPA1082	1082	PHG XPA1082	XPA2240	2240	PHG XPA2240
XPA1107	1107	PHG XPA1107	XPA2360	2360	PHG XPA2360
XPA1120	1120	PHG XPA1120	XPA2500	2500	PHG XPA2500
XPA1157	1157	PHG XPA1157	XPA2650	2650	PHG XPA2650
XPA1180	1180	PHG XPA1180	XPA2800	2800	PHG XPA2800
XPA1207	1207	PHG XPA1207	XPA3000	3000	PHG XPA3000
XPA1232	1232	PHG XPA1232	XPA3150	3150	PHG XPA3150
XPA1250	1250	PHG XPA1250	XPA3350	3350	PHG XPA3350
XPA1257	1257	PHG XPA1257	XPA3550	3550	PHG XPA3550

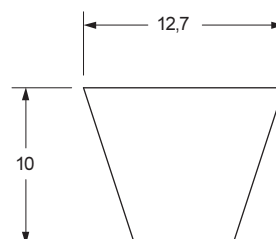

XPB Section Cogged Raw Edge

Belt marking	Pitch length	Designation	Belt marking	Pitch length	Designation
	mm			mm	
XPB1250	1250	PHG XPB1250	XPB2120	2120	PHG XPB2120
XPB1260	1260	PHG XPB1260	XPB2150	2150	PHG XPB2150
XPB1320	1320	PHG XPB1320	XPB2240	2240	PHG XPB2240
XPB1340	1340	PHG XPB1340	XPB2280	2280	PHG XPB2280
XPB1400	1400	PHG XPB1400	XPB2360	2360	PHG XPB2360
XPB1410	1410	PHG XPB1410	XPB2500	2500	PHG XPB2500
XPB1500	1500	PHG XPB1500	XPB2530	2530	PHG XPB2530
XPB1590	1590	PHG XPB1590	XPB2650	2650	PHG XPB2650
XPB1600	1600	PHG XPB1600	XPB2680	2680	PHG XPB2680
XPB1690	1690	PHG XPB1690	XPB2800	2800	PHG XPB2800
XPB1700	1700	PHG XPB1700	XPB3000	3000	PHG XPB3000
XPB1800	1800	PHG XPB1800	XPB3150	3150	PHG XPB3150
XPB1900	1900	PHG XPB1900	XPB3350	3350	PHG XPB3350
XPB2000	2000	PHG XPB2000	XPB3550	3550	PHG XPB3550
XPB2020	2020	PHG XPB2020	-	-	-

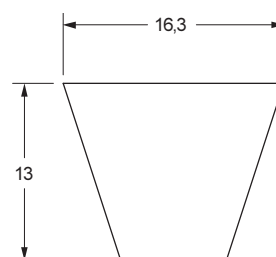

XPC Section Cogged Raw Edge

Belt marking	Pitch length	Designation	Belt marking	Pitch length	Designation
	mm			mm	
XPC2000	2000	PHG XPC2000	XPC2800	2800	PHG XPC2800
XPC2120	2120	PHG XPC2120	XPC3000	3000	PHG XPC3000
XPC2240	2240	PHG XPC2240	XPC3150	3150	PHG XPC3150
XPC2360	2360	PHG XPC2360	XPC3350	3350	PHG XPC3350
XPC2500	2500	PHG XPC2500	XPC3550	3550	PHG XPC3550
XPC2650	2650	PHG XPC2650	-	-	-

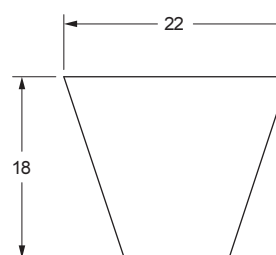

Non-standard lengths are also available.



Cogged raw edge classical belts



X10/ZX, X13/AX

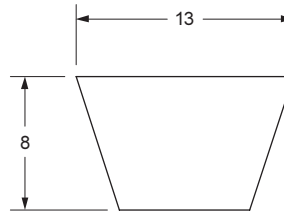
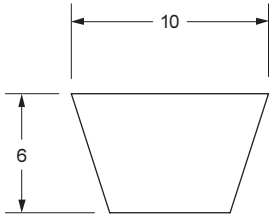

X10/ZX Section Cogged Raw Edge

Pitch length	Inside length		Designation	Pitch length	Inside length		Designation
	mm	inches			mm	inches	
405	387	15,25	PHG ZX15.25	950	940	37,00	PHG ZX37
420	406	16,00	PHG ZX16	965	953	37,50	PHG ZX37.5
465	445	17,50	PHG ZX17.5	975	959	37,75	PHG ZX37.75
470	457	18,00	PHG ZX18	980	965	38,00	PHG ZX38
495	483	19,00	PHG ZX19	1005	984	38,75	PHG ZX38.75
555	540	21,25	PHG ZX21.25	1025	1003	39,50	PHG ZX39.5
585	565	22,25	PHG ZX22.25	1035	1016	40,00	PHG ZX40
590	572	22,50	PHG ZX22.5	1050	1035	40,75	PHG ZX40.75
600	584	23,00	PHG ZX23	1055	1041	41,00	PHG ZX41
620	610	24,00	PHG ZX24	1075	1054	41,50	PHG ZX41.5
650	635	25,00	PHG ZX25	1080	1067	42,00	PHG ZX42
675	654	25,75	PHG ZX25.75	1105	1092	43,00	PHG ZX43
680	660	26,00	PHG ZX26	1125	1105	43,50	PHG ZX43.5
685	667	26,25	PHG ZX26.25	1130	1118	44,00	PHG ZX44
690	673	26,50	PHG ZX26.5	1155	1143	45,00	PHG ZX45
700	686	27,00	PHG ZX27	1170	1149	45,25	PHG ZX45.25
710	692	27,25	PHG ZX27.25	1200	1181	46,50	PHG ZX46.5
725	711	28,00	PHG ZX28	1230	1207	47,50	PHG ZX47.5
740	724	28,50	PHG ZX28.5	1255	1232	48,50	PHG ZX48.5
750	737	29,00	PHG ZX29	1290	1270	50,00	PHG ZX50
770	749	29,50	PHG ZX29.5	1340	1321	52,00	PHG ZX52
775	756	29,75	PHG ZX29.75	1380	1346	53,00	PHG ZX53
780	762	30,00	PHG ZX30	1390	1372	54,00	PHG ZX54
800	787	31,00	PHG ZX31	1420	1397	55,00	PHG ZX55
820	800	31,50	PHG ZX31.5	1465	1448	57,00	PHG ZX57
840	813	32,00	PHG ZX32	1515	1499	59,00	PHG ZX59
845	826	32,50	PHG ZX32.5	1570	1549	61,00	PHG ZX61
850	838	33,00	PHG ZX33	1620	1600	63,00	PHG ZX63
860	851	33,50	PHG ZX33.5	1670	1651	65,00	PHG ZX65
875	864	34,00	PHG ZX34	1695	1676	66,00	PHG ZX66
890	876	34,50	PHG ZX34.5	1720	1702	67,00	PHG ZX67
900	889	35,00	PHG ZX35	1750	1727	68,00	PHG ZX68
915	895	35,25	PHG ZX35.25	1770	1753	69,00	PHG ZX69
920	902	35,50	PHG ZX35.5	1820	1803	71,00	PHG ZX71
930	914	36,00	PHG ZX36	2000	1981	78,00	PHG ZX78
940	927	36,50	PHG ZX36.5	-	-	-	-

X13/AX Section Cogged Raw Edge

Pitch length	Inside length		Designation	Pitch length	Inside length		Designation
	mm	inches			mm	inches	
570	533	21,00	PHG AX21	1580	1549	61,00	PHG AX61
590	559	22,00	PHG AX22	1610	1575	62,00	PHG AX62
620	584	23,00	PHG AX23	1640	1600	63,00	PHG AX63
630	597	23,50	PHG AX23.5	1660	1626	64,00	PHG AX64
640	610	24,00	PHG AX24	1690	1651	65,00	PHG AX65
670	635	25,00	PHG AX25	1710	1676	66,00	PHG AX66
700	660	26,00	PHG AX26	1740	1702	67,00	PHG AX67
710	673	26,50	PHG AX26.5	1760	1727	68,00	PHG AX68
720	686	27,00	PHG AX27	1790	1753	69,00	PHG AX69
740	711	28,00	PHG AX28	1810	1778	70,00	PHG AX70
770	737	29,00	PHG AX29	1840	1803	71,00	PHG AX71
790	762	30,00	PHG AX30	1860	1829	72,00	PHG AX72
820	787	31,00	PHG AX31	1890	1854	73,00	PHG AX73
850	813	32,00	PHG AX32	1920	1880	74,00	PHG AX74
870	838	33,00	PHG AX33	1940	1905	75,00	PHG AX75
890	864	34,00	PHG AX34	1960	1930	76,00	PHG AX76
920	889	35,00	PHG AX35	1990	1956	77,00	PHG AX77
930	902	35,50	PHG AX35.5	2020	1981	78,00	PHG AX78
950	914	36,00	PHG AX36	2050	2007	79,00	PHG AX79
970	940	37,00	PHG AX37	2070	2032	80,00	PHG AX80
980	953	37,50	PHG AX37.5	2090	2057	81,00	PHG AX81
990	965	38,00	PHG AX38	2120	2083	82,00	PHG AX82
1020	991	39,00	PHG AX39	2140	2108	83,00	PHG AX83
1050	1016	40,00	PHG AX40	2170	2134	84,00	PHG AX84
1070	1041	41,00	PHG AX41	2200	2159	85,00	PHG AX85
1085	1054	41,50	PHG AX41.5	2220	2184	86,00	PHG AX86
1100	1067	42,00	PHG AX42	2240	2210	87,00	PHG AX87
1130	1092	43,00	PHG AX43	2270	2235	88,00	PHG AX88
1150	1118	44,00	PHG AX44	2300	2261	89,00	PHG AX89
1180	1143	45,00	PHG AX45	2320	2286	90,00	PHG AX90
1190	1156	45,50	PHG AX45.5	2350	2311	91,00	PHG AX91
1200	1168	46,00	PHG AX46	2400	2362	93,00	PHG AX93
1230	1194	47,00	PHG AX47	2420	2388	94,00	PHG AX94
1250	1219	48,00	PHG AX48	2450	2413	95,00	PHG AX95
1280	1245	49,00	PHG AX49	2480	2438	96,00	PHG AX96
1300	1270	50,00	PHG AX50	2500	2464	97,00	PHG AX97
1330	1295	51,00	PHG AX51	2520	2489	98,00	PHG AX98
1360	1321	52,00	PHG AX52	2570	2540	100,00	PHG AX100
1380	1346	53,00	PHG AX53	2650	2616	103,00	PHG AX103
1410	1372	54,00	PHG AX54	2680	2642	104,00	PHG AX104
1430	1397	55,00	PHG AX55	2700	2667	105,00	PHG AX105
1460	1422	56,00	PHG AX56	2830	2794	110,00	PHG AX110
1480	1448	57,00	PHG AX57	2880	2845	112,00	PHG AX112
1510	1473	58,00	PHG AX58	3030	2997	118,00	PHG AX118
1530	1499	59,00	PHG AX59	3190	3150	124,00	PHG AX124
1550	1524	60,00	PHG AX60	3390	3353	132,00	PHG AX132

Non-standard lengths are also available.



Cogged raw edge classical belts

X17/BX, X22/CX

- ▶ Belts
- ▶ Chains
- ▶ Couplings
- ▶ Bushings and Hubs
- ▶ Sprockets
- ▶ Pulleys
- ▶ Smart tools

X17/BX Section Cogged Raw Edge

Pitch length			Designation	Pitch length			Designation
mm	mm	inches		mm	mm	inches	
624	584	23,0	PHG BX23	1820	1778	70,0	PHG BX70
675	635	25,0	PHG BX25	1850	1803	71,0	PHG BX71
700	660	26,0	PHG BX26	1870	1829	72,0	PHG BX72
750	711	28,0	PHG BX28	1900	1854	73,0	PHG BX73
770	737	29,0	PHG BX29	1920	1880	74,0	PHG BX74
800	762	30,0	PHG BX30	1950	1905	75,0	PHG BX75
830	787	31,0	PHG BX31	1970	1930	76,0	PHG BX76
860	813	32,0	PHG BX32	2000	1956	77,0	PHG BX77
880	838	33,0	PHG BX33	2020	1981	78,0	PHG BX78
910	864	34,0	PHG BX34	2050	2007	79,0	PHG BX79
920	876	34,5	PHG BX34.5	2070	2032	80,0	PHG BX80
930	889	35,0	PHG BX35	2100	2057	81,0	PHG BX81
960	914	36,0	PHG BX36	2130	2083	82,0	PHG BX82
980	940	37,0	PHG BX37	2150	2108	83,0	PHG BX83
1000	965	38,0	PHG BX38	2180	2134	84,0	PHG BX84
1030	991	39,0	PHG BX39	2200	2159	85,0	PHG BX85
1060	1016	40,0	PHG BX40	2230	2184	86,0	PHG BX86
1080	1041	41,0	PHG BX41	2250	2210	87,0	PHG BX87
1100	1067	42,0	PHG BX42	2280	2235	88,0	PHG BX88
1130	1092	43,0	PHG BX43	2300	2261	89,0	PHG BX89
1160	1118	44,0	PHG BX44	2330	2286	90,0	PHG BX90
1180	1143	45,0	PHG BX45	2350	2311	91,0	PHG BX91
1195	1156	45,5	PHG BX45.5	2380	2337	92,0	PHG BX92
1210	1168	46,0	PHG BX46	2400	2362	93,0	PHG BX93
1225	1181	46,5	PHG BX46.5	2420	2388	94,0	PHG BX94
1240	1194	47,0	PHG BX47	2450	2413	95,0	PHG BX95
1260	1219	48,0	PHG BX48	2480	2438	96,0	PHG BX96
1290	1245	49,0	PHG BX49	2500	2464	97,0	PHG BX97
1310	1270	50,0	PHG BX50	2530	2489	98,0	PHG BX98
1340	1295	51,0	PHG BX51	2560	2515	99,0	PHG BX99
1370	1321	52,0	PHG BX52	2580	2540	100,0	PHG BX100
1390	1346	53,0	PHG BX53	2660	2616	103,0	PHG BX103
1410	1372	54,0	PHG BX54	2680	2642	104,0	PHG BX104
1440	1397	55,0	PHG BX55	2700	2667	105,0	PHG BX105
1460	1422	56,0	PHG BX56	2740	2692	106,0	PHG BX106
1490	1448	57,0	PHG BX57	2790	2743	108,0	PHG BX108
1510	1473	58,0	PHG BX58	2840	2794	110,0	PHG BX110
1540	1499	59,0	PHG BX59	2890	2845	112,0	PHG BX112
1560	1524	60,0	PHG BX60	2910	2870	113,0	PHG BX113
1590	1549	61,0	PHG BX61	2960	2921	115,0	PHG BX115
1620	1575	62,0	PHG BX62	2990	2946	116,0	PHG BX116
1640	1600	63,0	PHG BX63	3040	2997	118,0	PHG BX118
1670	1626	64,0	PHG BX64	3090	3048	120,0	PHG BX120
1690	1651	65,0	PHG BX65	3165	3124	123,0	PHG BX123
1720	1676	66,0	PHG BX66	3200	3150	124,0	PHG BX124
1740	1702	67,0	PHG BX67	3240	3200	126,0	PHG BX126
1760	1727	68,0	PHG BX68	3290	3251	128,0	PHG BX128
1800	1753	69,0	PHG BX69	3400	3353	132,0	PHG BX132

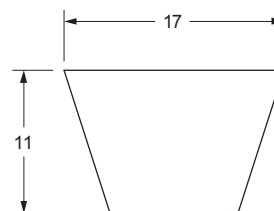

X22/CX Section Cogged Raw Edge

Pitch length			Designation	Pitch length			Designation
mm	mm	inches		mm	mm	inches	
1050	991	39,0	PHG CX39	2290	2235	88,0	PHG CX88
1150	1092	43,0	PHG CX43	2340	2286	90,0	PHG CX90
1300	1245	49,0	PHG CX49	2420	2362	93,0	PHG CX93
1350	1295	51,0	PHG CX51	2490	2438	96,0	PHG CX96
1370	1321	52,0	PHG CX52	2550	2489	98,0	PHG CX98
1450	1397	55,0	PHG CX55	2600	2540	100,0	PHG CX100
1560	1499	59,0	PHG CX59	2620	2565	101,0	PHG CX101
1580	1524	60,0	PHG CX60	2720	2667	105,0	PHG CX105
1630	1575	62,0	PHG CX62	2825	2769	109,0	PHG CX109
1760	1702	67,0	PHG CX67	2850	2794	110,0	PHG CX110
1780	1727	68,0	PHG CX68	2880	2819	111,0	PHG CX111
1860	1803	71,0	PHG CX71	2900	2845	112,0	PHG CX112
1880	1829	72,0	PHG CX72	2980	2921	115,0	PHG CX115
1950	1905	75,0	PHG CX75	3050	2997	118,0	PHG CX118
2040	1981	78,0	PHG CX78	3100	3048	120,0	PHG CX120
2060	2007	79,0	PHG CX79	3210	3150	124,0	PHG CX124
2110	2057	81,0	PHG CX81	3310	3251	128,0	PHG CX128
2220	2159	85,0	PHG CX85	3410	3353	132,0	PHG CX132

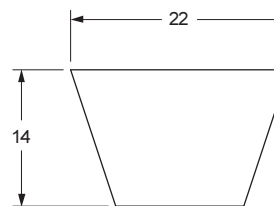

Non-standard lengths are also available.



Cogged raw edge narrow wedge belts

3VX, 5VX



3VX/9NX Section Cogged Raw Edge

Outside length		Designation	Outside length		Designation
mm	inches		mm	inches	
635	25,0	PHG 3VX250	1600	63,0	PHG 3VX630
673	26,5	PHG 3VX265	1702	67,0	PHG 3VX670
711	28,0	PHG 3VX280	1803	71,0	PHG 3VX710
762	30,0	PHG 3VX300	1905	75,0	PHG 3VX750
800	31,5	PHG 3VX315	2032	80,0	PHG 3VX800
851	33,5	PHG 3VX335	2159	85,0	PHG 3VX850
902	35,5	PHG 3VX355	2286	90,0	PHG 3VX900
953	37,5	PHG 3VX375	2413	95,0	PHG 3VX950
1016	40,0	PHG 3VX400	2540	100,0	PHG 3VX1000
1080	42,5	PHG 3VX425	2692	106,0	PHG 3VX1060
1143	45,0	PHG 3VX450	2845	112,0	PHG 3VX1120
1207	47,5	PHG 3VX475	2997	118,0	PHG 3VX1180
1270	50,0	PHG 3VX500	3175	125,0	PHG 3VX1250
1346	53,0	PHG 3VX530	3353	132,0	PHG 3VX1320
1422	56,0	PHG 3VX560	3556	140,0	PHG 3VX1400
1524	60,0	PHG 3VX600	3810	150,0	PHG 3VX1500

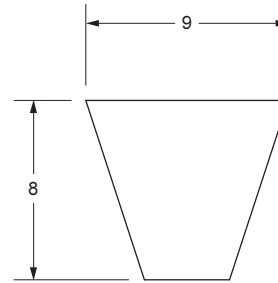

5VX/15NX Section Cogged Raw Edge

Outside length		Designation	Outside length		Designation
mm	inches		mm	inches	
1270	50,0	PHG 5VX500	2692	106,0	PHG 5VX1060
1346	53,0	PHG 5VX530	2845	112,0	PHG 5VX1120
1422	56,0	PHG 5VX560	2997	118,0	PHG 5VX1180
1524	60,0	PHG 5VX600	3175	125,0	PHG 5VX1250
1600	63,0	PHG 5VX630	3353	132,0	PHG 5VX1320
1702	67,0	PHG 5VX670	3556	140,0	PHG 5VX1400
1803	71,0	PHG 5VX710	3810	150,0	PHG 5VX1500
1905	75,0	PHG 5VX750	4064	160,0	PHG 5VX1600
2032	80,0	PHG 5VX800	4318	170,0	PHG 5VX1700
2159	85,0	PHG 5VX850	4572	180,0	PHG 5VX1800
2286	90,0	PHG 5VX900	4826	190,0	PHG 5VX1900
2413	95,0	PHG 5VX950	5080	200,0	PHG 5VX2000
2540	100,0	PHG 5VX1000	-	-	-

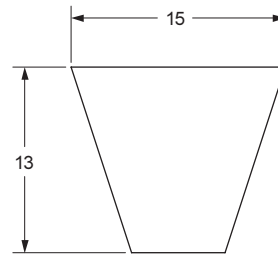

Non-standard lengths are also available.



Banded wedge belts

SPB, SPC

- ▶ Belts
- ▶ Chains
- ▶ Couplings
- ▶ Bushings and Hubs
- ▶ Sprockets
- ▶ Pulleys
- ▶ Smart tools

SPB Section Banded

Belt type	Pitch length	Designation	Belt type	Pitch length	Designation
	mm			mm	
SPB2000	2000	PHG SPB2000X...	SPB4250	4250	PHG SPB4250X...
SPB2120	2120	PHG SPB2120X...	SPB4500	4500	PHG SPB4500X...
SPB2240	2240	PHG SPB2240X...	SPB4750	4750	PHG SPB4750X...
SPB2360	2360	PHG SPB2360X...	SPB5000	5000	PHG SPB5000X...
SPB2500	2500	PHG SPB2500X...	SPB5300	5300	PHG SPB5300X...
SPB2650	2650	PHG SPB2650X...	SPB5600	5600	PHG SPB5600X...
SPB2800	2800	PHG SPB2800X...	SPB6000	6000	PHG SPB6000X...
SPB3000	3000	PHG SPB3000X...	SPB6300	6300	PHG SPB6300X...
SPB3150	3150	PHG SPB3150X...	SPB6700	6700	PHG SPB6700X...
SPB3350	3350	PHG SPB3350X...	SPB7100	7100	PHG SPB7100X...
SPB3550	3550	PHG SPB3550X...	SPB7500	7500	PHG SPB7500X...
SPB3750	3750	PHG SPB3750X...	SPB8000	8000	PHG SPB8000X...
SPB4000	4000	PHG SPB4000X...	-	-	-

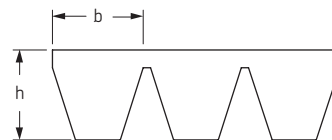

	SPB	SPC
b (mm)	16,5	22,0
h (mm)	15,6	22,6

Non-standard lengths are also available.

SPC Section Banded

Belt type	Pitch length	Designation	Belt type	Pitch length	Designation
	mm			mm	
SPC3000	3000	PHG SPC3000X...	SPC6300	6300	PHG SPC6300X...
SPC3150	3150	PHG SPC3150X...	SPC6700	6700	PHG SPC6700X...
SPC3350	3350	PHG SPC3350X...	SPC7100	7100	PHG SPC7100X...
SPC3550	3550	PHG SPC3550X...	SPC7500	7500	PHG SPC7500X...
SPC3750	3750	PHG SPC3750X...	SPC8000	8000	PHG SPC8000X...
SPC4000	4000	PHG SPC4000X...	SPC8500	8500	PHG SPC8500X...
SPC4250	4250	PHG SPC4250X...	SPC9000	9000	PHG SPC9000X...
SPC4500	4500	PHG SPC4500X...	SPC9500	9500	PHG SPC9500X...
SPC4750	4750	PHG SPC4750X...	SPC10000	10000	PHG SPC10000X...
SPC5000	5000	PHG SPC5000X...	SPC10600	10600	PHG SPC10600X...
SPC5300	5300	PHG SPC5300X...	SPC11200	11200	PHG SPC11200X...
SPC5600	5600	PHG SPC5600X...	SPC11800	11800	PHG SPC11800X...
SPC6000	6000	PHG SPC6000X...	SPC12500	12500	PHG SPC12500X...

To complete designation add number of bands. For example PHG SPC8000X4.



Banded classical belts

A, B, C, D



13/A Section Banded

Belt type	Pitch length		Designation	Belt type	Pitch length		Designation
	mm	inches			mm	inches	
A47	1230	47,0	PHG A47X...	A98	2520	98,0	PHG A98X...
A51	1330	51,0	PHG A51X...	A100	2570	100,0	PHG A100X...
A56	1460	56,0	PHG A56X...	A104	2680	104,0	PHG A104X...
A57	1480	57,0	PHG A57X...	A112	2880	112,0	PHG A112X...
A59	1530	59,0	PHG A59X...	A120	3080	120,0	PHG A120X...
A64	1660	64,0	PHG A64X...	A128	3290	128,0	PHG A128X...
A67	1740	67,0	PHG A67X...	A144	3690	144,0	PHG A144X...
A71	1840	71,0	PHG A71X...	A158	4043	158,0	PHG A158X...
A75	1940	75,0	PHG A75X...	A167	4270	167,0	PHG A167X...
A79	2050	79,0	PHG A79X...	A187	4780	187,0	PHG A187X...
A88	2270	88,0	PHG A88X...	-	-	-	-

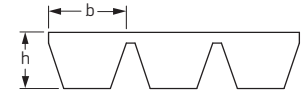

	A	B	C	D
b (mm)	13,0	17,0	22,0	32,0
h (mm)	9,9	13,0	16,2	22,4

Non-standard lengths are also available.

17/B Section Banded

Belt type	Pitch length		Designation	Belt type	Pitch length		Designation
	mm	inches			mm	inches	
B47	1240	47,0	PHG B47X...	B102	2630	102,0	PHG B102X...
B51	1340	51,0	PHG B51X...	B106	2740	106,0	PHG B106X...
B55	1440	55,0	PHG B55X...	B112	2890	112,0	PHG B112X...
B59	1540	59,0	PHG B59X...	B118	3040	118,0	PHG B118X...
B61	1590	61,0	PHG B61X...	B120	3090	120,0	PHG B120X...
B63	1640	63,0	PHG B63X...	B128	3290	128,0	PHG B128X...
B64	1670	64,0	PHG B64X...	B132	3400	132,0	PHG B132X...
B67	1740	67,0	PHG B67X...	B140	3600	140,0	PHG B140X...
B71	1850	71,0	PHG B71X...	B146	3750	146,0	PHG B146X...
B73	1900	73,0	PHG B73X...	B148	3800	148,0	PHG B148X...
B75	1950	75,0	PHG B75X...	B158	4060	158,0	PHG B158X...
B79	2050	79,0	PHG B79X...	B167	4280	167,0	PHG B167X...
B83	2150	83,0	PHG B83X...	B177	4540	177,0	PHG B177X...
B88	2280	88,0	PHG B88X...	B187	4800	187,0	PHG B187X...
B91	2350	91,0	PHG B91X...	B197	5044	197,0	PHG B197X...
B94,5	2435	94,5	PHG B94.5X...	B208	5340	208,0	PHG B208X...
B98	2530	98,0	PHG B98X...	B220	5630	220,0	PHG B220X...

22/C Section Banded

Belt type	Pitch length		Designation	Belt type	Pitch length		Designation
	mm	inches			mm	inches	
C90	2340	90,0	PHG C90X...	C167	4300	167,0	PHG C167X...
C98	2550	98,0	PHG C98X...	C177	4560	177,0	PHG C177X...
C108	2800	108,0	PHG C108X...	C187	4810	187,0	PHG C187X...
C120	3100	120,0	PHG C120X...	C197	5060	197,0	PHG C197X...
C128	3310	128,0	PHG C128X...	C208	5340	208,0	PHG C208X...
C140	3610	140,0	PHG C140X...	C220	5640	220,0	PHG C220X...
C146	3760	146,0	PHG C146X...	C236	6050	236,0	PHG C236X...
C151	3895	151,0	PHG C151X...	C248	6360	248,0	PHG C248X...

32/D Section Banded

Belt type	Pitch length		Designation	Belt type	Pitch length		Designation
	mm	inches			mm	inches	
D98	2560	98,0	PHG D98X...	D255	6560	255,0	PHG D255X...
D110	2870	110,0	PHG D110X...	D270	6940	270,0	PHG D270X...
D120	3130	120,0	PHG D120X...	D285	7320	285,0	PHG D285X...
D128	3330	128,0	PHG D128X...	D300	7700	300,0	PHG D300X...
D144	3730	144,0	PHG D144X...	D315	8080	315,0	PHG D315X...
D158	4080	158,0	PHG D158X...	D330	8460	330,0	PHG D330X...
D162	4190	162,0	PHG D162X...	D345	8840	345,0	PHG D345X...
D173	4470	173,0	PHG D173X...	D360	9220	360,0	PHG D360X...
D180	4650	180,0	PHG D180X...	D390	9980	390,0	PHG D390X...
D195	5030	195,0	PHG D195X...	D420	10740	420,0	PHG D420X...
D210	5400	210,0	PHG D210X...	D450	11505	450,0	PHG D450X...
D225	5790	225,0	PHG D225X...	D480	12270	480,0	PHG D480X...
D240	6170	240,0	PHG D240X...	D540	13790	540,0	PHG D540X...

To complete designation add number of bands. For example PHG D360X6.



Banded narrow wedge belts

3V, 5V, 8V

- ▶ Belts
- ▶ Chains
- ▶ Couplings
- ▶ Bushings and Hubs
- ▶ Sprockets
- ▶ Pulleys
- ▶ Smart tools

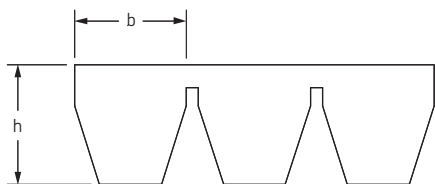

	3V	5V	8V
b(mm)	9,0	15,0	25,0
h(mm)	9,9	15,1	25,5

Non-standard lengths are also available

3V/9J Section Banded

Belt type	Outside length		Designation	Belt type	Outside length		Designation
	mm	inches			mm	inches	
3V500	1270	50	PHG 3V500X...	3V900	2286	90	PHG 3V900X...
3V530	1346	53	PHG 3V530X...	3V950	2413	95	PHG 3V950X...
3V560	1422	56	PHG 3V560X...	3V1000	2540	100	PHG 3V1000X...
3V600	1524	60	PHG 3V600X...	3V1060	2692	106	PHG 3V1060X...
3V630	1600	63	PHG 3V630X...	3V1120	2845	112	PHG 3V1120X...
3V670	1702	67	PHG 3V670X...	3V1180	2997	118	PHG 3V1180X...
3V710	1803	71	PHG 3V710X...	3V1250	3175	125	PHG 3V1250X...
3V750	1905	75	PHG 3V750X...	3V1320	3353	132	PHG 3V1320X...
3V800	2032	80	PHG 3V800X...	3V1400	3556	140	PHG 3V1400X...
3V850	2159	85	PHG 3V850X...	-	-	-	-

5V/15J Section Banded

Belt type	Outside length		Designation	Belt type	Outside length		Designation
	mm	inches			mm	inches	
5V560	1422	56	PHG 5V560X...	5V1400	3556	140	PHG 5V1400X...
5V600	1524	60	PHG 5V600X...	5V1500	3810	150	PHG 5V1500X...
5V630	1600	63	PHG 5V630X...	5V1600	4064	160	PHG 5V1600X...
5V670	1702	67	PHG 5V670X...	5V1700	4318	170	PHG 5V1700X...
5V710	1803	71	PHG 5V710X...	5V1800	4572	180	PHG 5V1800X...
5V750	1905	75	PHG 5V750X...	5V1900	4826	190	PHG 5V1900X...
5V800	2032	80	PHG 5V800X...	5V2000	5080	200	PHG 5V2000X...
5V850	2159	85	PHG 5V850X...	5V2120	5385	212	PHG 5V2120X...
5V900	2286	90	PHG 5V900X...	5V2240	5690	224	PHG 5V2240X...
5V950	2413	95	PHG 5V950X...	5V2360	5994	236	PHG 5V2360X...
5V1000	2540	100	PHG 5V1000X...	5V2500	6350	250	PHG 5V2500X...
5V1060	2692	106	PHG 5V1060X...	5V2650	6731	265	PHG 5V2650X...
5V1120	2845	112	PHG 5V1120X...	5V2800	7112	280	PHG 5V2800X...
5V1180	2997	118	PHG 5V1180X...	5V3000	7620	300	PHG 5V3000X...
5V1250	3175	125	PHG 5V1250X...	5V3150	8001	315	PHG 5V3150X...
5V1320	3353	132	PHG 5V1320X...	5V3350	8509	335	PHG 5V3350X...

8V/25J Section Banded

Belt type	Outside length		Designation	Belt type	Outside length		Designation
	mm	inches			mm	inches	
8V1000	2540	100	PHG 8V1000X...	8V2240	5690	224	PHG 8V2240X...
8V1060	2692	106	PHG 8V1060X...	8V2360	5994	236	PHG 8V2360X...
8V1120	2845	112	PHG 8V1120X...	8V2500	6350	250	PHG 8V2500X...
8V1180	2997	118	PHG 8V1180X...	8V2650	6731	265	PHG 8V2650X...
8V1250	3175	125	PHG 8V1250X...	8V2800	7112	280	PHG 8V2800X...
8V1320	3353	132	PHG 8V1320X...	8V3000	7620	300	PHG 8V3000X...
8V1400	3556	140	PHG 8V1400X...	8V3150	8001	315	PHG 8V3150X...
8V1500	3810	150	PHG 8V1500X...	8V3350	8509	335	PHG 8V3350X...
8V1600	4064	160	PHG 8V1600X...	8V3550	9017	355	PHG 8V3550X...
8V1700	4318	170	PHG 8V1700X...	8V3750	9525	375	PHG 8V3750X...
8V1800	4572	180	PHG 8V1800X...	8V4000	10160	400	PHG 8V4000X...
8V1900	4826	190	PHG 8V1900X...	8V4250	10795	425	PHG 8V4250X...
8V2000	5080	200	PHG 8V2000X...	8V4500	11430	450	PHG 8V4500X...
8V2120	5385	212	PHG 8V2120X...	8V4750	12065	475	PHG 8V4750X...

To complete designation add number of bands. For example PHG 8V3350X3.



Double classical (Hex) belts

AA, BB, CC



AA/HAA Section Double V-Belt

Pitch length	Inside length	Designation	Pitch length	Inside length	Designation
mm	inches		mm	inches	
2000	77	PHG AA77	2667	103	PHG AA103
2032	78	PHG AA78	2800	108	PHG AA108
2370	91	PHG AA91	3300	128	PHG AA128
2500	96	PHG AA96	3920	152	PHG AA152
2650	102	PHG AA102	-	-	-

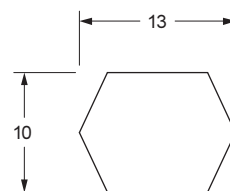

BB/HBB Section Double V-Belt

Pitch length	Inside length	Designation	Pitch length	Inside length	Designation
mm	inches		mm	inches	
1980	75	PHG BB75	3250	125	PHG BB125
2180	83	PHG BB83	3280	126	PHG BB126
2300	88	PHG BB88	3325	128	PHG BB128
2370	90	PHG BB90	3390	131	PHG BB131
2500	95	PHG BB95	3450	133	PHG BB133
2540	97	PHG BB97	3500	135	PHG BB135
2600	99	PHG BB99	3550	137	PHG BB137
2650	101	PHG BB101	3730	144	PHG BB144
2740	105	PHG BB105	3750	145	PHG BB145
2800	107	PHG BB107	4010	155	PHG BB155
2850	109	PHG BB109	4040	156	PHG BB156
2920	112	PHG BB112	4200	162	PHG BB162
3000	115	PHG BB115	4470	173	PHG BB173
3030	116	PHG BB116	4500	174	PHG BB174
3150	121	PHG BB121	4750	184	PHG BB184

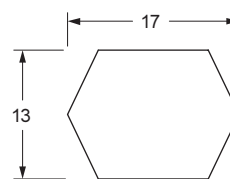

CC/HCC Section Double V-Belt

Pitch length	Inside length	Designation	Pitch length	Inside length	Designation
mm	inches		mm	inches	
2280	86	PHG CC86	4216	162	PHG CC162
2500	94	PHG CC94	4300	165	PHG CC165
2800	106	PHG CC106	4500	173	PHG CC173
3200	122	PHG CC122	5000	193	PHG CC193
3310	126	PHG CC126	5300	204	PHG CC204
3765	144	PHG CC144	5340	206	PHG CC206
4000	153	PHG CC153	5750	224	PHG CC224

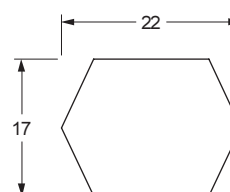

Non-standard lengths are also available.



Ribbed belts

PH, PJ

- ▶ Belts
- ▶ Chains
- ▶ Couplings
- ▶ Bushings and Hubs
- ▶ Sprockets
- ▶ Pulleys
- ▶ Smart tools

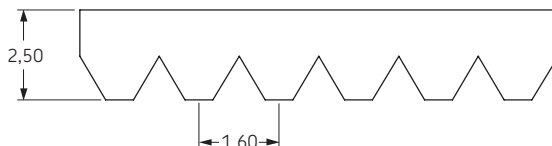

PH Section

Effective length		Designation	Effective length		Designation
mm	inches		mm	inches	
560	22,0	PHG ...PH560	1095	43,1	PHG ...PH1095
690	27,2	PHG ...PH690	1160	45,7	PHG ...PH1160
760	29,9	PHG ...PH760	1200	47,2	PHG ...PH1200
810	31,9	PHG ...PH810	1220	48,0	PHG ...PH1220
850	33,5	PHG ...PH850	1230	48,4	PHG ...PH1230
865	34,1	PHG ...PH865	1240	48,8	PHG ...PH1240
880	34,6	PHG ...PH880	1260	49,6	PHG ...PH1260
955	37,6	PHG ...PH955	1270	50,0	PHG ...PH1270
965	38,0	PHG ...PH965	1285	50,6	PHG ...PH1285
975	38,4	PHG ...PH975	1300	51,2	PHG ...PH1300
990	39,0	PHG ...PH990	1305	51,4	PHG ...PH1305
1010	39,8	PHG ...PH1010	1320	52,0	PHG ...PH1320
1080	42,5	PHG ...PH1080	1475	58,1	PHG ...PH1475
1090	42,9	PHG ...PH1090	1600	63,0	PHG ...PH1600

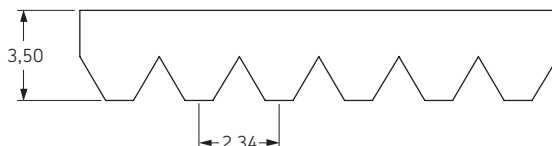

PJ Section

Effective length		Designation	Effective length		Designation
mm	inches		mm	inches	
540	21,3	PHG ...PJ540	1310	51,6	PHG ...PJ1310
550	21,7	PHG ...PJ550	1320	52,0	PHG ...PJ1320
580	22,8	PHG ...PJ580	1330	52,4	PHG ...PJ1330
610	24,0	PHG ...PJ610	1355	53,4	PHG ...PJ1355
660	26,0	PHG ...PJ660	1370	53,9	PHG ...PJ1370
710	28,0	PHG ...PJ710	1390	54,7	PHG ...PJ1390
720	28,3	PHG ...PJ720	1420	55,9	PHG ...PJ1420
760	29,9	PHG ...PJ760	1430	56,3	PHG ...PJ1430
810	31,9	PHG ...PJ810	1475	58,1	PHG ...PJ1475
830	32,7	PHG ...PJ830	1540	60,6	PHG ...PJ1540
860	33,9	PHG ...PJ860	1600	63,0	PHG ...PJ1600
910	35,8	PHG ...PJ910	1650	65,0	PHG ...PJ1650
955	37,6	PHG ...PJ955	1660	65,4	PHG ...PJ1660
965	38,0	PHG ...PJ965	1750	68,9	PHG ...PJ1750
1010	39,8	PHG ...PJ1010	1780	70,0	PHG ...PJ1780
1090	42,9	PHG ...PJ1090	1850	72,8	PHG ...PJ1850
1105	43,5	PHG ...PJ1105	1895	74,6	PHG ...PJ1895
1110	43,7	PHG ...PJ1110	1910	75,2	PHG ...PJ1910
1120	44,1	PHG ...PJ1120	1915	75,4	PHG ...PJ1915
1130	44,5	PHG ...PJ1130	1930	76,0	PHG ...PJ1930
1150	45,3	PHG ...PJ1150	1950	76,8	PHG ...PJ1950
1160	45,7	PHG ...PJ1160	1965	77,4	PHG ...PJ1965
1190	46,9	PHG ...PJ1190	1980	78,0	PHG ...PJ1980
1200	47,3	PHG ...PJ1200	1990	78,3	PHG ...PJ1990
1220	48,0	PHG ...PJ1220	2080	81,9	PHG ...PJ2080
1240	48,8	PHG ...PJ1240	2100	82,7	PHG ...PJ2100
1270	50,0	PHG ...PJ1270	2155	84,8	PHG ...PJ2155
1285	50,6	PHG ...PJ1285	2210	87,0	PHG ...PJ2210
1300	51,2	PHG ...PJ1300	2330	91,7	PHG ...PJ2330
1305	51,4	PHG ...PJ1305	2480	97,6	PHG ...PJ2480

Non-standard lengths are also available.

To complete designation add number of ribs. For example PHG 4PJ1320



Ribbed belts

PK

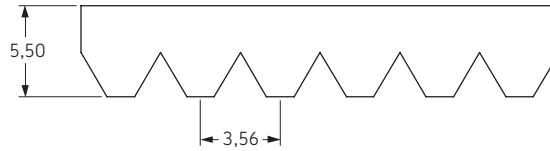

PK Section

Effective length		Designation	Effective length		Designation
mm	inches		mm	inches	
540	21,3	PHG ...PK540	1200	47,3	PHG ...PK1200
575	22,6	PHG ...PK575	1220	48,0	PHG ...PK1220
600	23,6	PHG ...PK600	1240	48,8	PHG ...PK1240
635	25,0	PHG ...PK635	1260	49,6	PHG ...PK1260
650	25,6	PHG ...PK650	1280	50,4	PHG ...PK1280
665	26,2	PHG ...PK665	1300	51,2	PHG ...PK1300
690	27,2	PHG ...PK690	1320	52,0	PHG ...PK1320
710	28,0	PHG ...PK710	1340	52,8	PHG ...PK1340
740	29,1	PHG ...PK740	1360	53,5	PHG ...PK1360
760	29,9	PHG ...PK760	1380	54,3	PHG ...PK1380
785	30,9	PHG ...PK785	1400	55,1	PHG ...PK1400
790	31,1	PHG ...PK790	1420	55,9	PHG ...PK1420
800	31,5	PHG ...PK800	1440	56,7	PHG ...PK1440
820	32,3	PHG ...PK820	1460	57,5	PHG ...PK1460
840	33,1	PHG ...PK840	1480	58,3	PHG ...PK1480
850	33,5	PHG ...PK850	1500	59,1	PHG ...PK1500
865	34,1	PHG ...PK865	1520	59,8	PHG ...PK1520
870	34,3	PHG ...PK870	1540	60,6	PHG ...PK1540
885	34,8	PHG ...PK885	1560	61,4	PHG ...PK1560
890	35,0	PHG ...PK890	1580	62,2	PHG ...PK1580
900	35,4	PHG ...PK900	1600	63,0	PHG ...PK1600
910	35,8	PHG ...PK910	1620	63,8	PHG ...PK1620
925	36,4	PHG ...PK925	1640	64,6	PHG ...PK1640
940	37,0	PHG ...PK940	1660	65,4	PHG ...PK1660
945	37,2	PHG ...PK945	1680	66,1	PHG ...PK1680
950	37,4	PHG ...PK950	1690	66,5	PHG ...PK1690
960	37,8	PHG ...PK960	1710	67,3	PHG ...PK1710
970	38,2	PHG ...PK970	1720	67,7	PHG ...PK1720
980	38,6	PHG ...PK980	1770	69,7	PHG ...PK1770
990	39,0	PHG ...PK990	1780	70,1	PHG ...PK1780
1000	39,4	PHG ...PK1000	1800	70,9	PHG ...PK1800
1010	39,8	PHG ...PK1010	1830	72,0	PHG ...PK1830
1015	40,0	PHG ...PK1015	1865	73,4	PHG ...PK1865
1020	40,2	PHG ...PK1020	1880	74,0	PHG ...PK1880
1040	40,9	PHG ...PK1040	1900	74,8	PHG ...PK1900
1050	41,3	PHG ...PK1050	1950	76,8	PHG ...PK1950
1060	41,7	PHG ...PK1060	1980	78,0	PHG ...PK1980
1075	42,3	PHG ...PK1075	2020	79,5	PHG ...PK2020
1080	42,5	PHG ...PK1080	2080	81,9	PHG ...PK2080
1090	42,9	PHG ...PK1090	2100	82,7	PHG ...PK2100
1100	43,3	PHG ...PK1100	2110	83,1	PHG ...PK2110
1120	44,1	PHG ...PK1120	2130	83,9	PHG ...PK2130
1130	44,5	PHG ...PK1130	2210	87,0	PHG ...PK2210
1140	44,9	PHG ...PK1140	2230	87,8	PHG ...PK2230
1150	45,3	PHG ...PK1150	2250	88,6	PHG ...PK2250
1160	45,7	PHG ...PK1160	2300	90,6	PHG ...PK2300
1170	46,1	PHG ...PK1170	2330	91,7	PHG ...PK2330
1180	46,5	PHG ...PK1180	2420	95,3	PHG ...PK2420
1190	46,9	PHG ...PK1190	-	-	-

Non-standard lengths are also available.

To complete designation add number of ribs. For example PHG 4PK1600

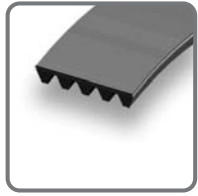

Ribbed belts

PL, PM

- ▶ Belts
- ▶ Chains
- ▶ Couplings
- ▶ Bushings and Hubs
- ▶ Sprockets
- ▶ Pulleys
- ▶ Smart tools

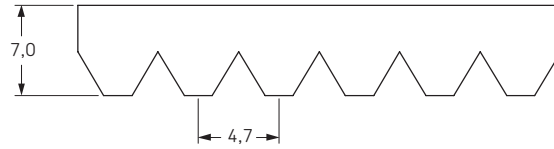

PL Section

Effective length		Designation	Effective length		Designation
mm	inches		mm	inches	
1075	42,5	PHG ...PL1075	2197	86,5	PHG ...PL2197
1270	50,0	PHG ...PL1270	2235	88,0	PHG ...PL2235
1333	52,5	PHG ...PL1333	2324	91,5	PHG ...PL2324
1371	54,0	PHG ...PL1371	2362	93,0	PHG ...PL2362
1397	55,0	PHG ...PL1397	2476	97,5	PHG ...PL2476
1422	56,0	PHG ...PL1422	2515	99,0	PHG ...PL2515
1562	61,5	PHG ...PL1562	2705	106,5	PHG ...PL2705
1613	63,5	PHG ...PL1613	2743	108,0	PHG ...PL2743
1664	65,5	PHG ...PL1664	2845	112,0	PHG ...PL2845
1715	67,5	PHG ...PL1715	2895	114,0	PHG ...PL2895
1764	69,5	PHG ...PL1764	2921	115,0	PHG ...PL2921
1803	71,0	PHG ...PL1803	2997	116,0	PHG ...PL2997
1841	72,5	PHG ...PL1841	3086	121,5	PHG ...PL3086
1943	76,5	PHG ...PL1943	3124	123,0	PHG ...PL3124
1981	78,0	PHG ...PL1981	3289	129,5	PHG ...PL3289
2020	79,5	PHG ...PL2020	3327	131,0	PHG ...PL3327
2070	81,5	PHG ...PL2070	3492	137,5	PHG ...PL3492
2096	82,5	PHG ...PL2096	3696	145,5	PHG ...PL3696
2134	84,0	PHG ...PL2134	4051	159,5	PHG ...PL4051

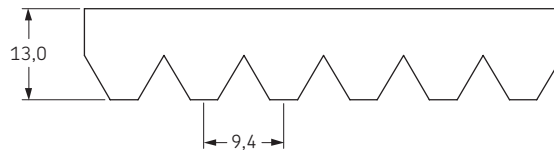

PM Section

Effective length		Designation	Effective length		Designation
mm	inches		mm	inches	
2693	106,0	PHG ...PM2693	3531	139,0	PHG ...PM3531
2832	111,5	PHG ...PM2832	3734	147,0	PHG ...PM3734
2921	115,0	PHG ...PM2921	4089	161,0	PHG ...PM4089
3010	118,5	PHG ...PM3010	4191	165,0	PHG ...PM4191
3124	123,0	PHG ...PM3124	4470	176,0	PHG ...PM4470
3327	131,0	PHG ...PM3327	4648	183,0	PHG ...PM4648

Non-standard lengths are also available.

To complete designation add number of ribs. For example PHG 6PM5410



Classical timing belts

MXL

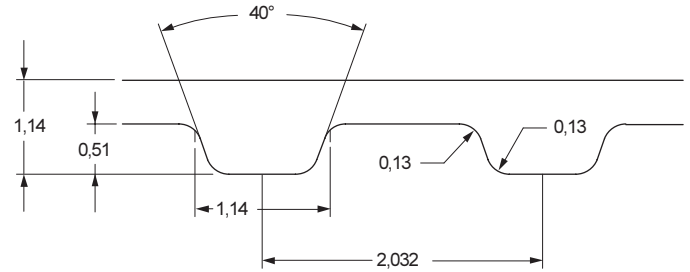

Belt marking	Number of teeth	Pitch length		Designation	Belt marking	Number of teeth	Pitch length		Designation	Belt marking	Number of teeth	Pitch length		Designation
		inches	mm				inches	mm				inches	mm	
21-MXL	26	2,08	52,83	PHG 21-MXL-...	85-MXL	106	8,48	215,39	PHG 85-MXL-...	180-MXL	225	18,00	457,20	PHG 180-MXL-...
22-MXL	27	2,16	54,86	PHG 22-MXL-...	86-MXL	108	8,64	219,46	PHG 86-MXL-...	182-MXL	228	18,20	462,28	PHG 182-MXL-...
26-MXL	33	2,64	67,06	PHG 26-MXL-...	87-MXL	109	8,72	221,49	PHG 87-MXL-...	185-MXL	232	18,56	471,42	PHG 185-MXL-...
28-MXL	35	2,80	71,12	PHG 28-MXL-...	88-MXL	110	8,80	223,52	PHG 88-MXL-...	189-MXL	236	18,88	479,55	PHG 189-MXL-...
32-MXL	40	3,20	81,28	PHG 32-MXL-...	89-MXL	112	8,96	227,58	PHG 89-MXL-...	191-MXL	239	19,12	485,65	PHG 191-MXL-...
34-MXL	43	3,44	87,38	PHG 34-MXL-...	90-MXL	113	9,04	229,62	PHG 90-MXL-...	192-MXL	240	19,20	487,68	PHG 192-MXL-...
36-MXL	45	3,60	91,44	PHG 36-MXL-...	91-MXL	114	9,12	231,65	PHG 91-MXL-...	199-MXL	249	19,92	505,97	PHG 199-MXL-...
39-MXL	49	3,92	99,57	PHG 39-MXL-...	92-MXL	115	9,20	233,68	PHG 92-MXL-...	200-MXL	250	20,00	508,00	PHG 200-MXL-...
40-MXL	50	4,00	101,60	PHG 40-MXL-...	93-MXL	116	9,28	235,71	PHG 93-MXL-...	205-MXL	256	20,48	520,19	PHG 205-MXL-...
41-MXL	51	4,08	103,63	PHG 41-MXL-...	94-MXL	118	9,44	239,78	PHG 94-MXL-...	212-MXL	265	21,20	538,48	PHG 212-MXL-...
41,6-MXL	52	4,16	105,66	PHG 41,6-MXL-...	96-MXL	120	9,60	243,84	PHG 96-MXL-...	218-MXL	273	21,84	554,74	PHG 218-MXL-...
42-MXL	53	4,24	107,70	PHG 42-MXL-...	97,6-MXL	122	9,76	247,90	PHG 97,6-MXL-...	221-MXL	276	22,08	560,83	PHG 221-MXL-...
43-MXL	54	4,32	109,73	PHG 43-MXL-...	98-MXL	123	9,84	249,94	PHG 98-MXL-...	224-MXL	280	22,40	568,96	PHG 224-MXL-...
44-MXL	55	4,40	111,76	PHG 44-MXL-...	100-MXL	125	10,00	254,00	PHG 100-MXL-...	232-MXL	290	23,20	589,28	PHG 232-MXL-...
45-MXL	56	4,48	113,79	PHG 45-MXL-...	101-MXL	126	10,08	256,03	PHG 101-MXL-...	236-MXL	295	23,60	599,44	PHG 236-MXL-...
46-MXL	58	4,64	117,86	PHG 46-MXL-...	106-MXL	132	10,56	268,22	PHG 106-MXL-...	238-MXL	298	23,84	605,54	PHG 238-MXL-...
47-MXL	59	4,72	119,89	PHG 47-MXL-...	106,4-MXL	133	10,64	270,26	PHG 106,4-MXL-...	240-MXL	300	24,00	609,60	PHG 240-MXL-...
48-MXL	60	4,80	121,92	PHG 48-MXL-...	108-MXL	135	10,80	274,32	PHG 108-MXL-...	244-MXL	305	24,40	619,76	PHG 244-MXL-...
49-MXL	61	4,88	123,95	PHG 49-MXL-...	109-MXL	136	10,88	276,35	PHG 109-MXL-...	250-MXL	312	24,96	633,98	PHG 250-MXL-...
49,6-MXL	62	4,96	125,98	PHG 49,6-MXL-...	109,6-MXL	137	10,96	278,38	PHG 109,6-MXL-...	254-MXL	318	25,44	646,18	PHG 254-MXL-...
50-MXL	63	5,04	128,02	PHG 50-MXL-...	110-MXL	138	11,04	280,42	PHG 110-MXL-...	256-MXL	320	25,60	650,24	PHG 256-MXL-...
51-MXL	64	5,12	130,05	PHG 51-MXL-...	111-MXL	139	11,12	282,45	PHG 111-MXL-...	262-MXL	328	26,24	666,50	PHG 262-MXL-...
52-MXL	65	5,20	132,08	PHG 52-MXL-...	112-MXL	140	11,20	284,48	PHG 112-MXL-...	269-MXL	336	26,88	682,75	PHG 269-MXL-...
53-MXL	66	5,28	134,11	PHG 53-MXL-...	113-MXL	142	11,36	288,54	PHG 113-MXL-...	278-MXL	347	27,76	705,10	PHG 278-MXL-...
53,6-MXL	67	5,36	136,14	PHG 53,6-MXL-...	115-MXL	144	11,52	292,61	PHG 115-MXL-...	290-MXL	362	28,96	735,58	PHG 290-MXL-...
54-MXL	68	5,44	138,18	PHG 54-MXL-...	116-MXL	145	11,60	294,64	PHG 116-MXL-...	302-MXL	378	30,24	768,10	PHG 302-MXL-...
56-MXL	70	5,60	142,24	PHG 56-MXL-...	118-MXL	148	11,84	300,74	PHG 118-MXL-...	320-MXL	400	32,00	812,80	PHG 320-MXL-...
57-MXL	71	5,68	144,27	PHG 57-MXL-...	119-MXL	149	11,92	302,77	PHG 119-MXL-...	326-MXL	408	32,64	829,06	PHG 326-MXL-...
58-MXL	72	5,76	146,30	PHG 58-MXL-...	120-MXL	150	12,00	304,80	PHG 120-MXL-...	358-MXL	448	35,84	910,34	PHG 358-MXL-...
58,4-MXL	73	5,84	148,34	PHG 58,4-MXL-...	121-MXL	152	12,16	308,86	PHG 121-MXL-...	370-MXL	463	37,04	940,82	PHG 370-MXL-...
60-MXL	75	6,00	152,40	PHG 60-MXL-...	122-MXL	153	12,24	310,90	PHG 122-MXL-...	378-MXL	472	37,76	959,10	PHG 378-MXL-...
61-MXL	76	6,08	154,43	PHG 61-MXL-...	123-MXL	154	12,32	312,93	PHG 123-MXL-...	403-MXL	504	40,32	1024,13	PHG 403-MXL-...
61,6-MXL	77	6,16	156,46	PHG 61,6-MXL-...	124-MXL	155	12,40	314,96	PHG 124-MXL-...	418-MXL	522	41,76	1060,70	PHG 418-MXL-...
62-MXL	78	6,24	158,50	PHG 62-MXL-...	125-MXL	156	12,48	316,99	PHG 125-MXL-...	425-MXL	531	42,48	1078,99	PHG 425-MXL-...
63-MXL	79	6,32	160,53	PHG 63-MXL-...	126-MXL	158	12,64	321,06	PHG 126-MXL-...	437-MXL	546	43,68	1109,47	PHG 437-MXL-...
64-MXL	80	6,40	162,56	PHG 64-MXL-...	128-MXL	160	12,80	325,12	PHG 128-MXL-...	438-MXL	548	43,84	1113,54	PHG 438-MXL-...
65-MXL	82	6,56	166,62	PHG 65-MXL-...	130-MXL	162	12,96	329,18	PHG 130-MXL-...	456-MXL	570	45,60	1158,24	PHG 456-MXL-...
66-MXL	83	6,64	168,66	PHG 66-MXL-...	132-MXL	165	13,20	335,28	PHG 132-MXL-...	466-MXL	583	46,64	1184,66	PHG 466-MXL-...
68-MXL	85	6,80	172,72	PHG 68-MXL-...	134-MXL	168	13,44	341,38	PHG 134-MXL-...	480-MXL	600	48,00	1219,20	PHG 480-MXL-...
69-MXL	87	6,96	176,78	PHG 69-MXL-...	136-MXL	170	13,60	345,44	PHG 136-MXL-...	518-MXL	648	51,84	1316,74	PHG 518-MXL-...
70-MXL	88	7,04	178,82	PHG 70-MXL-...	140-MXL	175	14,00	355,60	PHG 140-MXL-...	544-MXL	680	54,40	1381,76	PHG 544-MXL-...
71-MXL	89	7,12	180,85	PHG 71-MXL-...	144-MXL	180	14,40	365,76	PHG 144-MXL-...	600-MXL	750	60,00	1524,00	PHG 600-MXL-...
72-MXL	90	7,20	182,88	PHG 72-MXL-...	147-MXL	184	14,72	373,89	PHG 147-MXL-...	608-MXL	760	60,80	1544,32	PHG 608-MXL-...
73-MXL	92	7,36	186,94	PHG 73-MXL-...	152-MXL	190	15,20	386,08	PHG 152-MXL-...	640-MXL	800	64,00	1625,60	PHG 640-MXL-...
75-MXL	94	7,52	191,01	PHG 75-MXL-...	154-MXL	192	15,36	390,14	PHG 154-MXL-...	764-MXL	955	76,40	1940,56	PHG 764-MXL-...
76-MXL	95	7,60	193,04	PHG 76-MXL-...	155-MXL	194	15,52	394,21	PHG 155-MXL-...	765-MXL	957	76,56	1944,62	PHG 765-MXL-...
77-MXL	97	7,76	197,10	PHG 77-MXL-...	156-MXL	195	15,60	396,24	PHG 156-MXL-...	810-MXL	1012	80,96	2056,38	PHG 810-MXL-...
78-MXL	98	7,84	199,14	PHG 78-MXL-...	160-MXL	200	16,00	406,40	PHG 160-MXL-...	824-MXL	1030	82,40	2092,96	PHG 824-MXL-...
80-MXL	100	8,00	203,20	PHG 80-MXL-...	165-MXL	206	16,48	418,59	PHG 165-MXL-...	848-MXL	1060	84,80	2153,92	PHG 848-MXL-...
81-MXL	102	8,16	207,26	PHG 81-MXL-...	168-MXL	210	16,80	426,72	PHG 168-MXL-...	910-MXL	1137	90,96	2310,38	PHG 910-MXL-...
82-MXL	103	8,24	209,30	PHG 82-MXL-...	169-MXL	212	16,96	430,78	PHG 169-MXL-...	1000-MXL	1250	100,00	2540,00	PHG 1000-MXL-...
84-MXL	105	8,40	213,36	PHG 84-MXL-...	177-MXL	221	17,68	449,07	PHG 177-MXL-...	-	-	-	-	-

To complete designation add three digits for belt width in 1/100ths of an inch; e.g. for a 1/4" width add 025 or for a 3/8" width add 037.

Non-standard lengths may also be available.

Full sleeves are available in various widths. Please contact your SKF Authorized Distributor.



Classical timing belts

XL

- ▶ Belts
- ▶ Chains
- ▶ Couplings
- ▶ Bushings and Hubs
- ▶ Sprockets
- ▶ Pulleys
- ▶ Smart tools

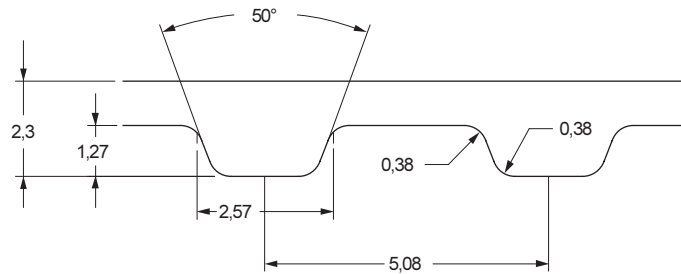

Belt marking	Number of teeth	Pitch length		Designation	Belt marking	Number of teeth	Pitch length		Designation
		inches	mm				inches	mm	
44-XL	22	4,4	111,76	PHG 44-XL-...	206-XL	103	20,6	523,24	PHG 206-XL-...
60-XL	30	6,0	152,40	PHG 60-XL-...	208-XL	104	20,8	528,32	PHG 208-XL-...
70-XL	35	7,0	177,80	PHG 70-XL-...	210-XL	105	21,0	533,40	PHG 210-XL-...
76-XL	38	7,6	193,04	PHG 76-XL-...	212-XL	106	21,2	538,48	PHG 212-XL-...
80-XL	40	8,0	203,20	PHG 80-XL-...	214-XL	107	21,4	543,56	PHG 214-XL-...
82-XL	41	8,2	208,28	PHG 82-XL-...	220-XL	110	22,0	558,80	PHG 220-XL-...
84-XL	42	8,4	213,36	PHG 84-XL-...	228-XL	114	22,8	579,12	PHG 228-XL-...
88-XL	44	8,8	223,52	PHG 88-XL-...	230-XL	115	23,0	584,20	PHG 230-XL-...
90-XL	45	9,0	228,60	PHG 90-XL-...	234-XL	117	23,4	594,36	PHG 234-XL-...
92-XL	46	9,2	233,68	PHG 92-XL-...	236-XL	118	23,6	599,44	PHG 236-XL-...
94-XL	47	9,4	238,76	PHG 94-XL-...	240-XL	120	24,0	609,60	PHG 240-XL-...
96-XL	48	9,6	243,84	PHG 96-XL-...	248-XL	124	24,8	629,92	PHG 248-XL-...
98-XL	49	9,8	248,92	PHG 98-XL-...	250-XL	125	25,0	635,00	PHG 250-XL-...
100-XL	50	10,0	254,00	PHG 100-XL-...	256-XL	128	25,6	650,24	PHG 256-XL-...
102-XL	51	10,2	259,08	PHG 102-XL-...	260-XL	130	26,0	660,40	PHG 260-XL-...
104-XL	52	10,4	264,16	PHG 104-XL-...	270-XL	135	27,0	685,80	PHG 270-XL-...
106-XL	53	10,6	269,24	PHG 106-XL-...	276-XL	138	27,6	701,04	PHG 276-XL-...
108-XL	54	10,8	274,32	PHG 108-XL-...	280-XL	140	28,0	711,20	PHG 280-XL-...
110-XL	55	11,0	279,40	PHG 110-XL-...	282-XL	141	28,2	716,28	PHG 282-XL-...
112-XL	56	11,2	284,48	PHG 112-XL-...	286-XL	143	28,6	726,44	PHG 286-XL-...
114-XL	57	11,4	289,56	PHG 114-XL-...	290-XL	145	29,0	736,60	PHG 290-XL-...
116-XL	58	11,6	294,64	PHG 116-XL-...	300-XL	150	30,0	762,00	PHG 300-XL-...
118-XL	59	11,8	299,72	PHG 118-XL-...	304-XL	152	30,4	772,16	PHG 304-XL-...
120-XL	60	12,0	304,80	PHG 120-XL-...	310-XL	155	31,0	787,40	PHG 310-XL-...
122-XL	61	12,2	309,88	PHG 122-XL-...	316-XL	158	31,6	802,64	PHG 316-XL-...
124-XL	62	12,4	314,96	PHG 124-XL-...	320-XL	160	32,0	812,80	PHG 320-XL-...
126-XL	63	12,6	320,04	PHG 126-XL-...	326-XL	163	32,6	828,04	PHG 326-XL-...
128-XL	64	12,8	325,12	PHG 128-XL-...	330-XL	165	33,0	838,20	PHG 330-XL-...
130-XL	65	13,0	330,20	PHG 130-XL-...	340-XL	170	34,0	863,60	PHG 340-XL-...
132-XL	66	13,2	335,28	PHG 132-XL-...	344-XL	172	34,4	873,76	PHG 344-XL-...
134-XL	67	13,4	340,36	PHG 134-XL-...	348-XL	174	34,8	883,92	PHG 348-XL-...
136-XL	68	13,6	345,44	PHG 136-XL-...	352-XL	176	35,2	894,08	PHG 352-XL-...
140-XL	70	14,0	355,60	PHG 140-XL-...	360-XL	180	36,0	914,40	PHG 360-XL-...
142-XL	71	14,2	360,68	PHG 142-XL-...	364-XL	182	36,4	924,56	PHG 364-XL-...
144-XL	72	14,4	365,76	PHG 144-XL-...	372-XL	186	37,2	944,88	PHG 372-XL-...
146-XL	73	14,6	370,84	PHG 146-XL-...	376-XL	188	37,6	955,04	PHG 376-XL-...
150-XL	75	15,0	381,00	PHG 150-XL-...	380-XL	190	38,0	965,20	PHG 380-XL-...
152-XL	76	15,2	386,08	PHG 152-XL-...	384-XL	192	38,4	975,36	PHG 384-XL-...
154-XL	77	15,4	391,16	PHG 154-XL-...	390-XL	195	39,0	990,60	PHG 390-XL-...
156-XL	78	15,6	396,24	PHG 156-XL-...	400-XL	200	40,0	1016,00	PHG 400-XL-...
160-XL	80	16,0	406,40	PHG 160-XL-...	412-XL	206	41,2	1046,48	PHG 412-XL-...
162-XL	81	16,2	411,48	PHG 162-XL-...	414-XL	207	41,4	1051,56	PHG 414-XL-...
164-XL	82	16,4	416,56	PHG 164-XL-...	424-XL	212	42,4	1076,96	PHG 424-XL-...
166-XL	83	16,6	421,64	PHG 166-XL-...	432-XL	216	43,2	1097,28	PHG 432-XL-...
170-XL	85	17,0	431,80	PHG 170-XL-...	450-XL	225	45,0	1143,00	PHG 450-XL-...
172-XL	86	17,2	436,88	PHG 172-XL-...	460-XL	230	46,0	1168,40	PHG 460-XL-...
176-XL	88	17,6	447,04	PHG 176-XL-...	490-XL	245	49,0	1244,60	PHG 490-XL-...
180-XL	90	18,0	457,20	PHG 180-XL-...	564-XL	282	56,4	1432,56	PHG 564-XL-...
182-XL	91	18,2	462,28	PHG 182-XL-...	580-XL	290	58,0	1473,20	PHG 580-XL-...
184-XL	92	18,4	467,36	PHG 184-XL-...	612-XL	306	61,2	1554,48	PHG 612-XL-...
188-XL	94	18,8	477,52	PHG 188-XL-...	630-XL	315	63,0	1600,20	PHG 630-XL-...
190-XL	95	19,0	482,60	PHG 190-XL-...	670-XL	335	67,0	1701,80	PHG 670-XL-...
194-XL	97	19,4	492,76	PHG 194-XL-...	710-XL	355	71,0	1803,40	PHG 710-XL-...
196-XL	98	19,6	497,84	PHG 196-XL-...	720-XL	360	72,0	1828,80	PHG 720-XL-...
198-XL	99	19,8	502,92	PHG 198-XL-...	788-XL	394	78,8	2001,52	PHG 788-XL-...
200-XL	100	20,0	508,00	PHG 200-XL-...	860-XL	430	86,0	2184,40	PHG 860-XL-...
202-XL	101	20,2	513,08	PHG 202-XL-...	1032-XL	516	103,2	2621,28	PHG 1032-XL-...

To complete designation add three digits for belt width in 1/100ths of an inch; e.g. for a 1/4" width add 025 or for a 3/8" width add 037.

Non-standard lengths may also be available.

Full sleeves are available in various widths. Please contact your SKF Authorized Distributor.



Classical timing belts

L

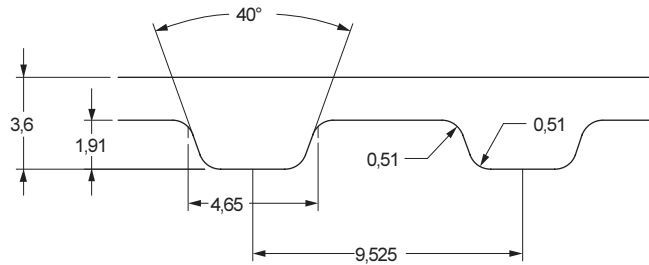

Belt marking	Number of teeth	Pitch length		Designation	Belt marking	Number of teeth	Pitch length		Designation
		inches	mm				inches	mm	
67-L	18	6,75	171,45	PHG 67-L-...	371-L	99	37,13	942,98	PHG 371-L-...
98-L	26	9,75	247,65	PHG 98-L-...	375-L	100	37,50	952,50	PHG 375-L-...
109-L	29	10,88	276,23	PHG 109-L-...	382-L	102	38,25	971,55	PHG 382-L-...
113-L	30	11,25	285,75	PHG 113-L-...	387-L	103	38,63	981,08	PHG 387-L-...
124-L	33	12,38	314,33	PHG 124-L-...	390-L	104	39,00	990,60	PHG 390-L-...
130-L	35	13,13	333,38	PHG 130-L-...	394-L	105	39,38	1000,13	PHG 394-L-...
135-L	36	13,50	342,90	PHG 135-L-...	397-L	106	39,75	1009,65	PHG 397-L-...
143-L	38	14,25	361,95	PHG 143-L-...	405-L	108	40,50	1028,70	PHG 405-L-...
150-L	40	15,00	381,00	PHG 150-L-...	408-L	109	40,88	1038,23	PHG 408-L-...
154-L	41	15,38	390,53	PHG 154-L-...	412-L	110	41,25	1047,75	PHG 412-L-...
158-L	42	15,75	400,05	PHG 158-L-...	420-L	112	42,00	1066,80	PHG 420-L-...
160-L	43	16,13	409,58	PHG 160-L-...	427-L	114	42,75	1085,85	PHG 427-L-...
165-L	44	16,50	419,10	PHG 165-L-...	435-L	116	43,50	1104,90	PHG 435-L-...
169-L	45	16,88	428,63	PHG 169-L-...	439-L	117	43,88	1114,43	PHG 439-L-...
173-L	46	17,25	438,15	PHG 173-L-...	442-L	119	44,20	1122,68	PHG 442-L-...
177-L	47	17,63	447,68	PHG 177-L-...	450-L	120	45,00	1143,00	PHG 450-L-...
180-L	48	18,00	457,20	PHG 180-L-...	453-L	121	45,38	1152,53	PHG 453-L-...
185-L	49	18,38	466,73	PHG 185-L-...	465-L	124	46,50	1181,10	PHG 465-L-...
187-L	50	18,75	476,25	PHG 187-L-...	480-L	128	48,00	1219,20	PHG 480-L-...
191-L	51	19,13	485,78	PHG 191-L-...	495-L	132	49,50	1257,30	PHG 495-L-...
195-L	52	19,50	495,30	PHG 195-L-...	510-L	136	51,00	1295,40	PHG 510-L-...
203-L	54	20,25	514,35	PHG 203-L-...	525-L	140	52,50	1333,50	PHG 525-L-...
210-L	56	21,00	533,40	PHG 210-L-...	540-L	144	54,00	1371,60	PHG 540-L-...
214-L	57	21,38	542,93	PHG 214-L-...	555-L	148	55,50	1409,70	PHG 555-L-...
217-L	58	21,75	552,45	PHG 217-L-...	548-L	148	54,80	1391,92	PHG 548-L-...
225-L	60	22,50	571,50	PHG 225-L-...	570-L	152	57,00	1447,80	PHG 570-L-...
232-L	62	23,25	590,55	PHG 232-L-...	574-L	153	57,38	1457,33	PHG 574-L-...
240-L	64	24,00	609,60	PHG 240-L-...	581-L	155	58,13	1476,38	PHG 581-L-...
244-L	65	24,38	619,13	PHG 244-L-...	585-L	156	58,50	1485,90	PHG 585-L-...
255-L	68	25,50	647,70	PHG 255-L-...	600-L	160	60,00	1524,00	PHG 600-L-...
263-L	70	26,25	666,75	PHG 263-L-...	619-L	165	61,88	1571,63	PHG 619-L-...
265-L	71	26,63	676,28	PHG 265-L-...	630-L	168	63,00	1600,20	PHG 630-L-...
270-L	72	27,00	685,80	PHG 270-L-...	634-L	169	63,38	1609,73	PHG 634-L-...
275-L	73	27,38	695,33	PHG 275-L-...	660-L	176	66,00	1676,40	PHG 660-L-...
277-L	74	27,75	704,85	PHG 277-L-...	694-L	185	69,38	1762,13	PHG 694-L-...
280-L	75	28,13	714,38	PHG 280-L-...	697-L	186	69,75	1771,65	PHG 697-L-...
285-L	76	28,50	723,90	PHG 285-L-...	720-L	192	72,00	1828,80	PHG 720-L-...
300-L	80	30,00	762,00	PHG 300-L-...	728-L	194	72,75	1847,85	PHG 728-L-...
304-L	81	30,38	771,53	PHG 304-L-...	731-L	195	73,13	1857,38	PHG 731-L-...
315-L	84	31,50	800,10	PHG 315-L-...	765-L	204	76,50	1943,10	PHG 765-L-...
320-L	85	31,88	809,63	PHG 320-L-...	863-L	230	86,25	2190,75	PHG 863-L-...
322-L	86	32,25	819,15	PHG 322-L-...	881-L	235	88,13	2238,38	PHG 881-L-...
328-L	87	32,63	828,68	PHG 328-L-...	915-L	244	91,50	2324,10	PHG 915-L-...
330-L	88	33,00	838,20	PHG 330-L-...	934-L	249	93,38	2371,73	PHG 934-L-...
334-L	89	33,38	847,73	PHG 334-L-...	1028-L	274	102,75	2609,85	PHG 1028-L-...
337-L	90	33,75	857,25	PHG 337-L-...	1148-L	306	114,75	2914,65	PHG 1148-L-...
341-L	91	34,13	866,78	PHG 341-L-...	1192-L	318	119,25	3028,95	PHG 1192-L-...
345-L	92	34,50	876,30	PHG 345-L-...	1406-L	375	140,63	3571,88	PHG 1406-L-...
352-L	94	35,25	895,35	PHG 352-L-...	1418-L	378	141,75	3600,45	PHG 1418-L-...
360-L	96	36,00	914,40	PHG 360-L-...	1675-L	447	167,63	4257,68	PHG 1675-L-...
367-L	98	36,75	933,45	PHG 367-L-...	1998-L	530	198,75	5048,25	PHG 1998-L-...

To complete designation add three digits for belt width in 1/100ths of an inch; e.g. for a 1/2" width add 050 or for a 3/4" width add 075.

Non-standard lengths may also be available.

Full sleeves are available in various widths. Please contact your SKF Authorized Distributor.



Classical timing belts

H

- ▶ Belts
- ▶ Chains
- ▶ Couplings
- ▶ Bushings and Hubs
- ▶ Sprockets
- ▶ Pulleys
- ▶ Smart tools

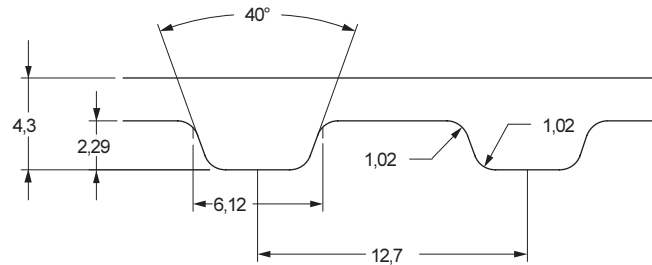

Belt marking	Number of teeth	Pitch length		Designation	Belt marking	Number of teeth	Pitch length		Designation
		inches	mm				inches	mm	
185-H	37	18,5	469,9	PHG 185-H-...	605-H	121	60,5	1536,7	PHG 605-H-...
200-H	40	20,0	508,0	PHG 200-H-...	630-H	126	63,0	1600,2	PHG 630-H-...
210-H	42	21,0	533,4	PHG 210-H-...	640-H	128	64,0	1625,6	PHG 640-H-...
220-H	44	22,0	558,8	PHG 220-H-...	650-H	130	65,0	1651,0	PHG 650-H-...
225-H	45	22,5	571,5	PHG 225-H-...	660-H	132	66,0	1676,4	PHG 660-H-...
230-H	46	23,0	584,2	PHG 230-H-...	670-H	134	67,0	1701,8	PHG 670-H-...
240-H	48	24,0	609,6	PHG 240-H-...	680-H	136	68,0	1727,2	PHG 680-H-...
250-H	50	25,0	635,0	PHG 250-H-...	700-H	140	70,0	1778,0	PHG 700-H-...
255-H	51	25,5	647,7	PHG 255-H-...	710-H	142	71,0	1803,4	PHG 710-H-...
260-H	52	26,0	660,4	PHG 260-H-...	720-H	144	72,0	1828,8	PHG 720-H-...
270-H	54	27,0	685,8	PHG 270-H-...	725-H	145	72,5	1841,5	PHG 725-H-...
280-H	56	28,0	711,2	PHG 280-H-...	730-H	146	73,0	1854,2	PHG 730-H-...
285-H	57	28,5	723,9	PHG 285-H-...	740-H	148	74,0	1879,6	PHG 740-H-...
290-H	58	29,0	736,6	PHG 290-H-...	750-H	150	75,0	1905,0	PHG 750-H-...
300-H	60	30,0	762,0	PHG 300-H-...	770-H	154	77,0	1955,8	PHG 770-H-...
310-H	62	31,0	787,4	PHG 310-H-...	785-H	157	78,5	1993,9	PHG 785-H-...
315-H	63	31,5	800,1	PHG 315-H-...	800-H	160	80,0	2032,0	PHG 800-H-...
320-H	64	32,0	812,8	PHG 320-H-...	810-H	162	81,0	2057,4	PHG 810-H-...
325-H	65	32,5	825,5	PHG 325-H-...	820-H	164	82,0	2082,8	PHG 820-H-...
330-H	66	33,0	838,2	PHG 330-H-...	840-H	168	84,0	2133,6	PHG 840-H-...
335-H	67	33,5	850,9	PHG 335-H-...	850-H	170	85,0	2159,0	PHG 850-H-...
340-H	68	34,0	863,6	PHG 340-H-...	860-H	172	86,0	2184,4	PHG 860-H-...
345-H	69	34,5	876,3	PHG 345-H-...	880-H	176	88,0	2235,2	PHG 880-H-...
350-H	70	35,0	889,0	PHG 350-H-...	900-H	180	90,0	2286,0	PHG 900-H-...
355-H	71	35,5	901,7	PHG 355-H-...	930-H	186	93,0	2362,2	PHG 930-H-...
360-H	72	36,0	914,4	PHG 360-H-...	950-H	190	95,0	2413,0	PHG 950-H-...
365-H	73	36,5	927,1	PHG 365-H-...	960-H	192	96,0	2438,4	PHG 960-H-...
370-H	74	37,0	939,8	PHG 370-H-...	980-H	196	98,0	2489,2	PHG 980-H-...
375-H	75	37,5	952,5	PHG 375-H-...	985-H	197	98,5	2501,9	PHG 985-H-...
380-H	76	38,0	965,2	PHG 380-H-...	1000-H	200	100,0	2540,0	PHG 1000-H-...
390-H	78	39,0	990,6	PHG 390-H-...	1020-H	204	102,0	2590,8	PHG 1020-H-...
395-H	79	39,5	1003,3	PHG 395-H-...	1050-H	210	105,0	2667,0	PHG 1050-H-...
400-H	80	40,0	1016,0	PHG 400-H-...	1085-H	217	108,5	2755,9	PHG 1085-H-...
405-H	81	40,5	1028,7	PHG 405-H-...	1100-H	220	110,0	2794,0	PHG 1100-H-...
410-H	82	41,0	1041,4	PHG 410-H-...	1120-H	224	112,0	2844,8	PHG 1120-H-...
420-H	84	42,0	1066,8	PHG 420-H-...	1140-H	228	114,0	2895,6	PHG 1140-H-...
430-H	86	43,0	1092,2	PHG 430-H-...	1150-H	230	115,0	2921,0	PHG 1150-H-...
445-H	89	44,5	1130,3	PHG 445-H-...	1175-H	235	117,5	2984,5	PHG 1175-H-...
450-H	90	45,0	1143,0	PHG 450-H-...	1200-H	240	120,0	3048,0	PHG 1200-H-...
460-H	92	46,0	1168,4	PHG 460-H-...	1250-H	250	125,0	3175,0	PHG 1250-H-...
465-H	93	46,5	1181,1	PHG 465-H-...	1260-H	252	126,0	3200,4	PHG 1260-H-...
480-H	96	48,0	1219,2	PHG 480-H-...	1270-H	254	127,0	3225,8	PHG 1270-H-...
485-H	97	48,5	1231,9	PHG 485-H-...	1325-H	265	132,5	3365,5	PHG 1325-H-...
490-H	98	49,0	1244,6	PHG 490-H-...	1350-H	270	135,0	3429,0	PHG 1350-H-...
500-H	100	50,0	1270,0	PHG 500-H-...	1400-H	280	140,0	3556,0	PHG 1400-H-...
510-H	102	51,0	1295,4	PHG 510-H-...	1440-H	288	144,0	3657,6	PHG 1440-H-...
515-H	103	51,5	1308,1	PHG 515-H-...	1450-H	290	145,0	3683,0	PHG 1450-H-...
520-H	104	52,0	1320,8	PHG 520-H-...	1510-H	302	151,0	3835,4	PHG 1510-H-...
525-H	105	52,5	1333,5	PHG 525-H-...	1535-H	307	153,5	3898,9	PHG 1535-H-...
530-H	106	53,0	1346,2	PHG 530-H-...	1550-H	310	155,0	3937,0	PHG 1550-H-...
540-H	108	54,0	1371,6	PHG 540-H-...	1560-H	312	156,0	3962,4	PHG 1560-H-...
550-H	110	55,0	1397,0	PHG 550-H-...	1600-H	320	160,0	4064,0	PHG 1600-H-...
560-H	112	56,0	1422,4	PHG 560-H-...	1630-H	326	163,0	4140,2	PHG 1630-H-...
565-H	113	56,5	1435,1	PHG 565-H-...	1660-H	332	166,0	4216,4	PHG 1660-H-...
570-H	114	57,0	1447,8	PHG 570-H-...	1700-H	340	170,0	4318,0	PHG 1700-H-...
580-H	116	58,0	1473,2	PHG 580-H-...	1855-H	371	185,5	4711,7	PHG 1855-H-...
585-H	117	58,5	1485,9	PHG 585-H-...	2200-H	440	220,0	5588,0	PHG 2200-H-...
590-H	118	59,0	1498,6	PHG 590-H-...	2360-H	472	236,0	5994,4	PHG 2360-H-...
600-H	120	60,0	1524,0	PHG 600-H-...	2500-H	500	250,0	6350,0	PHG 2500-H-...

To complete designation add three digits for belt width in 1/100ths of an inch; e.g. for a 1/2" width add 050 or for a 3/4" width add 075.

Non-standard lengths may also be available.

Full sleeves are available in various widths. Please contact your SKF Authorized Distributor.



Classical timing belts

XH, XXH



Belt marking	Number of teeth	Pitch length		Designation
		inches	mm	
463-XH	53	46,38	1117,93	PHG 463-XH-...
507-XH	58	50,75	1289,05	PHG 507-XH-...
560-XH	64	56,00	1422,40	PHG 560-XH-...
570-XH	65	56,88	1444,63	PHG 570-XH-...
580-XH	66	57,55	1466,85	PHG 580-XH-...
604-XH	69	60,38	1533,53	PHG 604-XH-...
630-XH	72	63,00	1600,20	PHG 630-XH-...
700-XH	80	70,00	1778,00	PHG 700-XH-...
735-XH	84	73,50	1866,90	PHG 735-XH-...
752-XH	86	75,25	1911,35	PHG 752-XH-...
770-XH	88	77,00	1955,80	PHG 770-XH-...
800-XH	91	79,63	2022,48	PHG 800-XH-...
805-XH	92	80,50	2044,70	PHG 805-XH-...
840-XH	96	84,00	2133,60	PHG 840-XH-...
901-XH	103	90,13	2289,18	PHG 901-XH-...
919-XH	105	91,88	2333,63	PHG 919-XH-...
927-XH	106	92,75	2355,85	PHG 927-XH-...
980-XH	112	98,00	2489,20	PHG 980-XH-...
1000-XH	114	99,75	2533,65	PHG 1000-XH-...
1120-XH	128	112,00	2844,80	PHG 1120-XH-...
1260-XH	144	126,00	3200,40	PHG 1260-XH-...
1400-XH	160	140,00	3556,00	PHG 1400-XH-...
1540-XH	176	154,00	3911,60	PHG 1540-XH-...
1575-XH	180	157,50	4000,50	PHG 1575-XH-...
1750-XH	200	175,00	4445,00	PHG 1750-XH-...
1873-XH	214	187,25	4756,15	PHG 1873-XH-...
2275-XH	260	227,50	5778,50	PHG 2275-XH-...

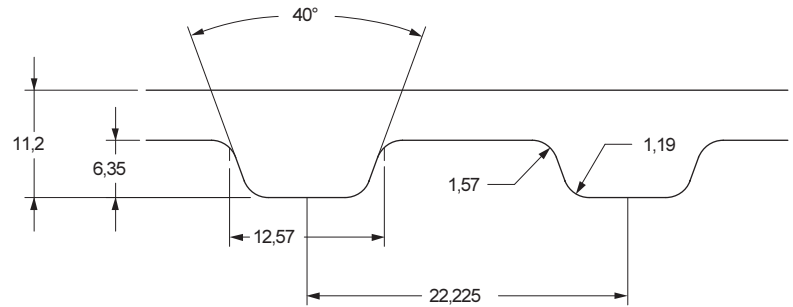

Belt marking	Number of teeth	Pitch length		Designation
		inches	mm	
625-XXH	50	62,50	1587,50	PHG 625-XXH-...
650-XXH	52	65,00	1651,00	PHG 650-XXH-...
700-XXH	56	70,00	1778,00	PHG 700-XXH-...
800-XXH	64	80,00	2032,00	PHG 800-XXH-...
900-XXH	72	90,00	2286,00	PHG 900-XXH-...
950-XXH	76	95,00	2413,00	PHG 950-XXH-...
1000-XXH	80	100,00	2540,00	PHG 1000-XXH-...
1050-XXH	84	105,00	2667,00	PHG 1050-XXH-...
1200-XXH	96	120,00	3048,00	PHG 1200-XXH-...
1250-XXH	100	125,00	3175,00	PHG 1250-XXH-...
1400-XXH	112	140,00	3556,00	PHG 1400-XXH-...
1563-XXH	125	156,25	3968,75	PHG 1563-XXH-...
1600-XXH	128	160,00	4064,00	PHG 1600-XXH-...
1700-XXH	136	170,00	4318,00	PHG 1700-XXH-...
1800-XXH	144	180,00	4572,00	PHG 1800-XXH-...
1925-XXH	154	192,50	4889,50	PHG 1925-XXH-...

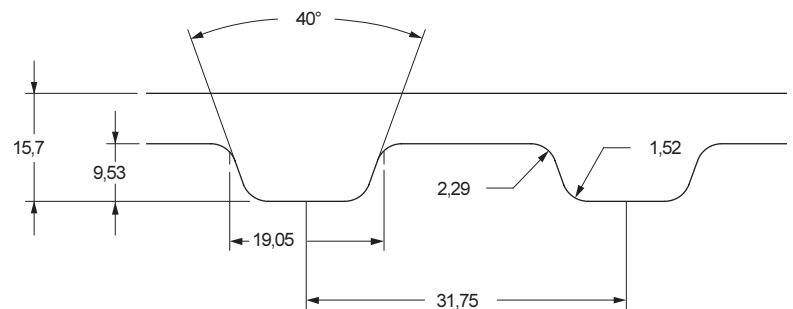

To complete designation add three digits for belt width in 1/100ths of an inch; e.g. for a 1" width add 100 or for a 2" width add 200.

Non-standard lengths may also be available.

Full sleeves are available in various widths. Please contact your SKF Authorized Distributor.



Double-sided classical timing belts

D-XL

- ▶ Belts
- ▶ Chains
- ▶ Couplings
- ▶ Bushings and Hubs
- ▶ Sprockets
- ▶ Pulleys
- ▶ Smart tools

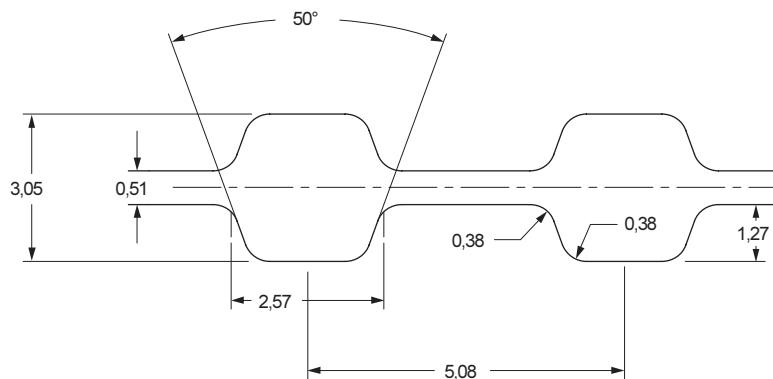

Belt marking	Number of teeth per side	Pitch length		Designation	Belt marking	Number of teeth per side	Pitch length		Designation
		inches	mm				inches	mm	
D-198-XL	99	19,8	502,92	PHG D-198-XL-...	D-310-XL	155	31,0	787,40	PHG D-310-XL-...
D-200-XL	100	20,0	508,00	PHG D-200-XL-...	D-316-XL	158	31,6	802,64	PHG D-316-XL-...
D-202-XL	101	20,2	513,08	PHG D-202-XL-...	D-320-XL	160	32,0	812,80	PHG D-320-XL-...
D-206-XL	103	20,6	523,24	PHG D-206-XL-...	D-326-XL	163	32,6	828,04	PHG D-326-XL-...
D-208-XL	104	20,8	528,32	PHG D-208-XL-...	D-330-XL	165	33,0	838,20	PHG D-330-XL-...
D-210-XL	105	21,0	533,40	PHG D-210-XL-...	D-340-XL	170	34,0	863,60	PHG D-340-XL-...
D-212-XL	106	21,2	538,48	PHG D-212-XL-...	D-344-XL	172	34,4	873,76	PHG D-344-XL-...
D-214-XL	107	21,4	543,56	PHG D-214-XL-...	D-348-XL	174	34,8	883,92	PHG D-348-XL-...
D-220-XL	110	22,0	558,80	PHG D-220-XL-...	D-352-XL	176	35,2	894,08	PHG D-352-XL-...
D-228-XL	114	22,8	579,12	PHG D-228-XL-...	D-360-XL	180	36,0	914,40	PHG D-360-XL-...
D-230-XL	115	23,0	584,20	PHG D-230-XL-...	D-364-XL	182	36,4	924,56	PHG D-364-XL-...
D-234-XL	117	23,4	594,36	PHG D-234-XL-...	D-372-XL	186	37,2	944,88	PHG D-372-XL-...
D-236-XL	118	23,6	599,44	PHG D-236-XL-...	D-376-XL	188	37,6	955,04	PHG D-376-XL-...
D-240-XL	120	24,0	609,60	PHG D-240-XL-...	D-380-XL	190	38,0	965,20	PHG D-380-XL-...
D-248-XL	124	24,8	629,92	PHG D-248-XL-...	D-384-XL	192	38,4	975,36	PHG D-384-XL-...
D-250-XL	125	25,0	635,00	PHG D-250-XL-...	D-390-XL	195	39,0	990,60	PHG D-390-XL-...
D-256-XL	128	25,6	650,24	PHG D-256-XL-...	D-400-XL	200	40,0	10160	PHG D-400-XL-...
D-260-XL	130	26,0	660,40	PHG D-260-XL-...	D-412-XL	206	41,2	1046,48	PHG D-412-XL-...
D-270-XL	135	27,0	685,80	PHG D-270-XL-...	D-414-XL	207	41,4	1051,56	PHG D-414-XL-...
D-276-XL	138	27,6	701,04	PHG D-276-XL-...	D-424-XL	212	42,4	1076,96	PHG D-424-XL-...
D-280-XL	140	28,0	711,20	PHG D-280-XL-...	D-432-XL	216	43,2	1097,28	PHG D-432-XL-...
D-282-XL	141	28,2	716,28	PHG D-282-XL-...	D-450-XL	225	45,0	1143,00	PHG D-450-XL-...
D-286-XL	143	28,6	726,44	PHG D-286-XL-...	D-460-XL	230	46,0	1168,40	PHG D-460-XL-...
D-290-XL	145	29,0	736,60	PHG D-290-XL-...	D-490-XL	245	49,0	1244,60	PHG D-490-XL-...
D-300-XL	150	30,0	762,00	PHG D-300-XL-...	D-564-XL	282	56,4	1432,56	PHG D-564-XL-...
D-304-XL	152	30,4	772,16	PHG D-304-XL-...	D-580-XL	290	58,0	1473,20	PHG D-580-XL-...

To complete designation add three digits for belt width in 1/100ths of an inch; e.g. for a 1/4" width add 025 or for a 3/8" width add 037.

Non-standard lengths may also be available.

Full sleeves are available in various widths. Please contact your SKF Authorized Distributor.



Double-sided classical timing belts

D-L

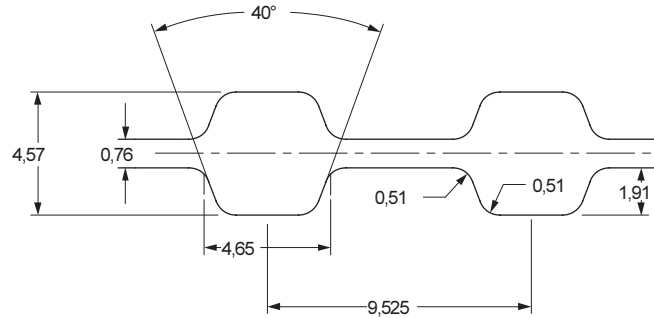

Belt marking	Number of teeth per side	Pitch length		Designation	Belt marking	Number of teeth per side	Pitch length		Designation
		inches	mm				inches	mm	
D-203-L	54	20,25	514,35	PHG D-203-L-...	D-371-L	99	37,13	942,98	PHG D-371-L-...
D-210-L	56	21,00	533,40	PHG D-210-L-...	D-375-L	100	37,50	952,50	PHG D-375-L-...
D-214-L	57	21,38	542,93	PHG D-214-L-...	D-382-L	102	38,25	971,55	PHG D-382-L-...
D-217-L	58	21,75	552,45	PHG D-217-L-...	D-387-L	103	38,63	981,08	PHG D-387-L-...
D-225-L	60	22,50	571,50	PHG D-225-L-...	D-390-L	104	39,00	990,60	PHG D-390-L-...
D-232-L	62	23,25	590,55	PHG D-232-L-...	D-394-L	105	39,38	1000,13	PHG D-394-L-...
D-240-L	64	24,00	609,60	PHG D-240-L-...	D-397-L	106	39,75	1009,65	PHG D-397-L-...
D-244-L	65	24,38	619,13	PHG D-244-L-...	D-405-L	108	40,50	1028,70	PHG D-405-L-...
D-255-L	68	25,50	647,70	PHG D-255-L-...	D-408-L	109	40,88	1038,23	PHG D-408-L-...
D-263-L	70	26,25	666,75	PHG D-263-L-...	D-412-L	110	41,25	1047,75	PHG D-412-L-...
D-265-L	71	26,63	676,28	PHG D-265-L-...	D-420-L	112	42,00	1066,80	PHG D-420-L-...
D-270-L	72	27,00	685,80	PHG D-270-L-...	D-427-L	114	42,75	1085,85	PHG D-427-L-...
D-275-L	73	27,38	695,33	PHG D-275-L-...	D-435-L	116	43,50	1104,90	PHG D-435-L-...
D-277-L	74	27,75	704,85	PHG D-277-L-...	D-439-L	117	43,88	1114,43	PHG D-439-L-...
D-280-L	75	28,13	714,38	PHG D-280-L-...	D-442-L	118	44,25	1123,95	PHG D-442-L-...
D-285-L	76	28,50	723,90	PHG D-285-L-...	D-450-L	120	45,00	1143,00	PHG D-450-L-...
D-300-L	80	30,00	762,00	PHG D-300-L-...	D-453-L	121	45,38	1152,53	PHG D-453-L-...
D-304-L	81	30,38	771,53	PHG D-304-L-...	D-465-L	124	46,50	1181,10	PHG D-465-L-...
D-315-L	84	31,50	800,10	PHG D-315-L-...	D-480-L	128	48,00	1219,20	PHG D-480-L-...
D-320-L	85	31,88	809,63	PHG D-320-L-...	D-495-L	132	49,50	1257,30	PHG D-495-L-...
D-322-L	86	32,25	819,15	PHG D-322-L-...	D-510-L	136	51,00	1295,40	PHG D-510-L-...
D-328-L	87	32,63	828,68	PHG D-328-L-...	D-525-L	140	52,50	1333,50	PHG D-525-L-...
D-330-L	88	33,00	838,20	PHG D-330-L-...	D-540-L	144	54,00	1371,60	PHG D-540-L-...
D-334-L	89	33,38	847,73	PHG D-334-L-...	D-548-L	146	54,75	1390,65	PHG D-548-L-...
D-337-L	90	33,75	857,25	PHG D-337-L-...	D-555-L	148	55,50	1409,70	PHG D-555-L-...
D-341-L	91	34,13	866,78	PHG D-341-L-...	D-570-L	152	57,00	1447,80	PHG D-570-L-...
D-345-L	92	34,50	876,30	PHG D-345-L-...	D-574-L	153	57,38	1457,33	PHG D-574-L-...
D-352-L	94	35,25	895,35	PHG D-352-L-...	D-581-L	155	58,13	1476,38	PHG D-581-L-...
D-360-L	96	36,00	914,40	PHG D-360-L-...	D-585-L	156	58,50	1485,90	PHG D-585-L-...
D-367-L	98	36,75	933,45	PHG D-367-L-...	-	-	-	-	-

To complete designation add three digits for belt width in 1/100ths of an inch; e.g. for a 1/2" width add 050 or for a 3/4" width add 075.

Non-standard lengths may also be available.

Full sleeves are available in various widths. Please contact your SKF Authorized Distributor.



Double-sided classical timing belts

D-H

- ▶ Belts
- ▶ Chains
- ▶ Couplings
- ▶ Bushings and Hubs
- ▶ Sprockets
- ▶ Pulleys
- ▶ Smart tools

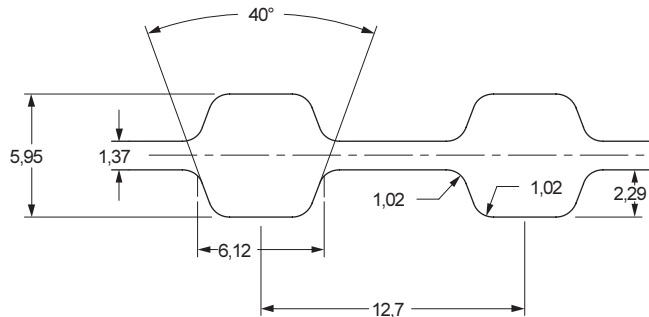

Belt marking	Number of teeth per side	Pitch length		Designation	Belt marking	Number of teeth per side	Pitch length		Designation
		inches	mm				inches	mm	
D-200-H	40	20,0	508,0	PHG D-200-H-...	D-605-H	121	60,5	1536,7	PHG D-605-H-...
D-210-H	42	21,0	533,4	PHG D-210-H-...	D-630-H	126	63,0	1600,2	PHG D-630-H-...
D-220-H	44	22,0	558,8	PHG D-220-H-...	D-640-H	128	64,0	1625,6	PHG D-640-H-...
D-225-H	45	22,5	571,5	PHG D-225-H-...	D-650-H	130	65,0	1651,0	PHG D-650-H-...
D-230-H	46	23,0	584,2	PHG D-230-H-...	D-660-H	132	66,0	1676,4	PHG D-660-H-...
D-240-H	48	24,0	609,6	PHG D-240-H-...	D-670-H	134	67,0	1701,8	PHG D-670-H-...
D-245-H	49	24,5	622,3	PHG D-245-H-...	D-680-H	136	68,0	1727,2	PHG D-680-H-...
D-250-H	50	25,0	635,0	PHG D-250-H-...	D-700-H	140	70,0	1778,0	PHG D-700-H-...
D-255-H	51	25,5	647,7	PHG D-255-H-...	D-710-H	142	71,0	1803,4	PHG D-710-H-...
D-260-H	52	26,0	660,4	PHG D-260-H-...	D-720-H	144	72,0	1828,8	PHG D-720-H-...
D-270-H	54	27,0	685,8	PHG D-270-H-...	D-725-H	145	72,5	1841,5	PHG D-725-H-...
D-280-H	56	28,0	711,2	PHG D-280-H-...	D-730-H	146	73,0	1854,2	PHG D-730-H-...
D-285-H	57	28,5	723,9	PHG D-285-H-...	D-740-H	148	74,0	1879,6	PHG D-740-H-...
D-290-H	58	29,0	736,6	PHG D-290-H-...	D-750-H	150	75,0	1905,0	PHG D-750-H-...
D-300-H	60	30,0	762,0	PHG D-300-H-...	D-770-H	154	77,0	1955,8	PHG D-770-H-...
D-310-H	62	31,0	787,4	PHG D-310-H-...	D-785-H	157	78,5	1993,9	PHG D-785-H-...
D-315-H	63	31,5	800,1	PHG D-315-H-...	D-800-H	160	80,0	2032,0	PHG D-800-H-...
D-320-H	64	32,0	812,8	PHG D-320-H-...	D-810-H	162	81,0	2057,4	PHG D-810-H-...
D-325-H	65	32,5	825,5	PHG D-325-H-...	D-820-H	164	82,0	2082,8	PHG D-820-H-...
D-330-H	66	33,0	838,2	PHG D-330-H-...	D-840-H	168	84,0	2133,6	PHG D-840-H-...
D-335-H	67	33,5	850,9	PHG D-335-H-...	D-850-H	170	85,0	2159,0	PHG D-850-H-...
D-340-H	68	34,0	863,6	PHG D-340-H-...	D-860-H	172	86,0	2184,4	PHG D-860-H-...
D-345-H	69	34,5	876,3	PHG D-345-H-...	D-880-H	176	88,0	2235,2	PHG D-880-H-...
D-350-H	70	35,0	889,0	PHG D-350-H-...	D-900-H	180	90,0	2286,0	PHG D-900-H-...
D-355-H	71	35,5	901,7	PHG D-355-H-...	D-930-H	186	93,0	2362,2	PHG D-930-H-...
D-360-H	72	36,0	914,4	PHG D-360-H-...	D-950-H	190	95,0	2413,0	PHG D-950-H-...
D-365-H	73	36,5	927,1	PHG D-365-H-...	D-960-H	192	96,0	2438,4	PHG D-960-H-...
D-370-H	74	37,0	939,8	PHG D-370-H-...	D-980-H	196	98,0	2489,2	PHG D-980-H-...
D-375-H	75	37,5	952,5	PHG D-375-H-...	D-985-H	197	98,5	2501,9	PHG D-985-H-...
D-380-H	76	38,0	965,2	PHG D-380-H-...	D-1000-H	200	100,0	2540,0	PHG D-1000-H-...
D-390-H	78	39,0	990,6	PHG D-390-H-...	D-1020-H	204	102,0	2590,8	PHG D-1020-H-...
D-395-H	79	39,5	1003,3	PHG D-395-H-...	D-1050-H	210	105,0	2667,0	PHG D-1050-H-...
D-400-H	80	40,0	1016,0	PHG D-400-H-...	D-1085-H	217	108,5	2755,9	PHG D-1085-H-...
D-405-H	81	40,5	1028,7	PHG D-405-H-...	D-1100-H	220	110,0	2794,0	PHG D-1100-H-...
D-410-H	82	41,0	1041,4	PHG D-410-H-...	D-1120-H	224	112,0	2844,8	PHG D-1120-H-...
D-420-H	84	42,0	1066,8	PHG D-420-H-...	D-1130-H	226	113,0	2870,2	PHG D-1130-H-...
D-430-H	86	43,0	1092,2	PHG D-430-H-...	D-1140-H	228	114,0	2895,6	PHG D-1140-H-...
D-445-H	89	44,5	1130,3	PHG D-445-H-...	D-1150-H	230	115,0	2921,0	PHG D-1150-H-...
D-450-H	90	45,0	1143,0	PHG D-450-H-...	D-1175-H	235	117,5	2984,5	PHG D-1175-H-...
D-460-H	92	46,0	1168,4	PHG D-460-H-...	D-1200-H	240	120,0	3048,0	PHG D-1200-H-...
D-465-H	93	46,5	1181,1	PHG D-465-H-...	D-1250-H	250	125,0	3175,0	PHG D-1250-H-...
D-470-H	94	47,0	1193,8	PHG D-470-H-...	D-1260-H	252	126,0	3200,4	PHG D-1260-H-...
D-480-H	96	48,0	1219,2	PHG D-480-H-...	D-1270-H	254	127,0	3225,8	PHG D-1270-H-...
D-485-H	97	48,5	1231,9	PHG D-485-H-...	D-1325-H	265	132,5	3365,5	PHG D-1325-H-...
D-490-H	98	49,0	1244,6	PHG D-490-H-...	D-1350-H	270	135,0	3429,0	PHG D-1350-H-...
D-500-H	100	50,0	1270,0	PHG D-500-H-...	D-1400-H	280	140,0	3556,0	PHG D-1400-H-...
D-510-H	102	51,0	1295,4	PHG D-510-H-...	D-1440-H	288	144,0	3657,6	PHG D-1440-H-...
D-515-H	103	51,5	1308,1	PHG D-515-H-...	D-1450-H	290	145,0	3683,0	PHG D-1450-H-...
D-520-H	104	52,0	1320,8	PHG D-520-H-...	D-1510-H	302	151,0	3835,4	PHG D-1510-H-...
D-525-H	105	52,5	1333,5	PHG D-525-H-...	D-1535-H	307	153,5	3898,9	PHG D-1535-H-...
D-530-H	106	53,0	1346,2	PHG D-530-H-...	D-1550-H	310	155,0	3937,0	PHG D-1550-H-...
D-540-H	108	54,0	1371,6	PHG D-540-H-...	D-1560-H	312	156,0	3962,4	PHG D-1560-H-...
D-550-H	110	55,0	1397,0	PHG D-550-H-...	D-1600-H	320	160,0	4064,0	PHG D-1600-H-...
D-560-H	112	56,0	1422,4	PHG D-560-H-...	D-1630-H	326	163,0	4140,2	PHG D-1630-H-...
D-565-H	113	56,5	1435,1	PHG D-565-H-...	D-1660-H	332	166,0	4216,4	PHG D-1660-H-...
D-570-H	114	57,0	1447,8	PHG D-570-H-...	D-1700-H	340	170,0	4318,0	PHG D-1700-H-...
D-580-H	116	58,0	1473,2	PHG D-580-H-...	D-1855-H	371	185,5	4711,7	PHG D-1855-H-...
D-585-H	117	58,5	1485,9	PHG D-585-H-...	D-2200-H	440	220,0	5588,0	PHG D-2200-H-...
D-590-H	118	59,0	1498,6	PHG D-590-H-...	D-2360-H	472	236,0	5994,4	PHG D-2360-H-...
D-600-H	120	60,0	1524,0	PHG D-600-H-...	D-2500-H	500	250,0	6350,0	PHG D-2500-H-...

To complete designation add three digits for belt width in 1/100ths of an inch; e.g. for a 1/2" width add 050 or for a 1" width add 100.

Non-standard lengths may also be available.

Full sleeves are available in various widths. Please contact your SKF Authorized Distributor.



HiTD belts

3M

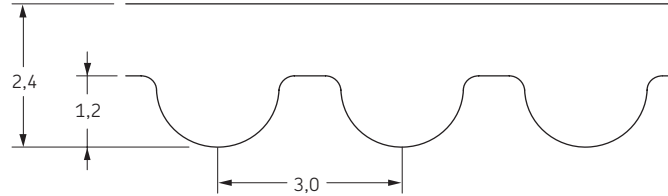

Belt marking	Number of teeth	Pitch length	Designation	Belt marking	Number of teeth	Pitch length	Designation	Belt marking	Number of teeth	Pitch length	Designation
		mm				mm				mm	
60-3M	20	60	PHG 60-3M-...	288-3M	96	288	PHG 288-3M-...	564-3M	188	564	PHG 564-3M-...
81-3M	27	81	PHG 81-3M-...	291-3M	97	291	PHG 291-3M-...	576-3M	192	576	PHG 576-3M-...
87-3M	29	87	PHG 87-3M-...	300-3M	100	300	PHG 300-3M-...	579-3M	193	579	PHG 579-3M-...
111-3M	37	111	PHG 111-3M-...	306-3M	102	306	PHG 306-3M-...	582-3M	194	582	PHG 582-3M-...
117-3M	39	117	PHG 117-3M-...	309-3M	103	309	PHG 309-3M-...	597-3M	199	597	PHG 597-3M-...
120-3M	40	120	PHG 120-3M-...	312-3M	104	312	PHG 312-3M-...	606-3M	202	606	PHG 606-3M-...
129-3M	43	129	PHG 129-3M-...	318-3M	106	318	PHG 318-3M-...	609-3M	203	609	PHG 609-3M-...
141-3M	47	141	PHG 141-3M-...	324-3M	108	324	PHG 324-3M-...	612-3M	204	612	PHG 612-3M-...
144-3M	48	144	PHG 144-3M-...	327-3M	109	327	PHG 327-3M-...	633-3M	211	633	PHG 633-3M-...
150-3M	50	150	PHG 150-3M-...	333-3M	111	333	PHG 333-3M-...	639-3M	213	639	PHG 639-3M-...
153-3M	51	153	PHG 153-3M-...	336-3M	112	336	PHG 336-3M-...	648-3M	216	648	PHG 648-3M-...
156-3M	52	156	PHG 156-3M-...	339-3M	113	339	PHG 339-3M-...	654-3M	218	654	PHG 654-3M-...
159-3M	53	159	PHG 159-3M-...	342-3M	114	342	PHG 342-3M-...	669-3M	223	669	PHG 669-3M-...
162-3M	54	162	PHG 162-3M-...	345-3M	115	345	PHG 345-3M-...	675-3M	225	675	PHG 675-3M-...
165-3M	55	165	PHG 165-3M-...	348-3M	116	348	PHG 348-3M-...	684-3M	228	684	PHG 684-3M-...
168-3M	56	168	PHG 168-3M-...	357-3M	119	357	PHG 357-3M-...	699-3M	233	699	PHG 699-3M-...
171-3M	57	171	PHG 171-3M-...	360-3M	120	360	PHG 360-3M-...	708-3M	236	708	PHG 708-3M-...
174-3M	58	174	PHG 174-3M-...	363-3M	121	363	PHG 363-3M-...	711-3M	237	711	PHG 711-3M-...
177-3M	59	177	PHG 177-3M-...	366-3M	122	366	PHG 366-3M-...	720-3M	240	720	PHG 720-3M-...
180-3M	60	180	PHG 180-3M-...	375-3M	125	375	PHG 375-3M-...	750-3M	250	750	PHG 750-3M-...
186-3M	62	186	PHG 186-3M-...	384-3M	128	384	PHG 384-3M-...	753-3M	251	753	PHG 753-3M-...
189-3M	63	189	PHG 189-3M-...	390-3M	130	390	PHG 390-3M-...	801-3M	267	801	PHG 801-3M-...
192-3M	64	192	PHG 192-3M-...	396-3M	132	396	PHG 396-3M-...	804-3M	268	804	PHG 804-3M-...
195-3M	65	195	PHG 195-3M-...	399-3M	133	399	PHG 399-3M-...	813-3M	271	813	PHG 813-3M-...
201-3M	67	201	PHG 201-3M-...	420-3M	140	420	PHG 420-3M-...	843-3M	281	843	PHG 843-3M-...
204-3M	68	204	PHG 204-3M-...	423-3M	141	423	PHG 423-3M-...	885-3M	295	885	PHG 885-3M-...
207-3M	69	207	PHG 207-3M-...	426-3M	142	426	PHG 426-3M-...	939-3M	313	939	PHG 939-3M-...
210-3M	70	210	PHG 210-3M-...	447-3M	149	447	PHG 447-3M-...	1125-3M	375	1125	PHG 1125-3M-...
213-3M	71	213	PHG 213-3M-...	459-3M	153	459	PHG 459-3M-...	1209-3M	403	1209	PHG 1209-3M-...
222-3M	74	222	PHG 222-3M-...	471-3M	157	471	PHG 471-3M-...	1245-3M	415	1245	PHG 1245-3M-...
225-3M	75	225	PHG 225-3M-...	474-3M	158	474	PHG 474-3M-...	1263-3M	421	1263	PHG 1263-3M-...
228-3M	76	228	PHG 228-3M-...	477-3M	159	477	PHG 477-3M-...	1344-3M	448	1344	PHG 1344-3M-...
234-3M	78	234	PHG 234-3M-...	480-3M	160	480	PHG 480-3M-...	1401-3M	467	1401	PHG 1401-3M-...
237-3M	79	237	PHG 237-3M-...	483-3M	161	483	PHG 483-3M-...	1569-3M	523	1569	PHG 1569-3M-...
240-3M	80	240	PHG 240-3M-...	486-3M	162	486	PHG 486-3M-...	1800-3M	600	1800	PHG 1800-3M-...
246-3M	82	246	PHG 246-3M-...	492-3M	164	492	PHG 492-3M-...	1950-3M	650	1950	PHG 1950-3M-...
252-3M	84	252	PHG 252-3M-...	495-3M	165	495	PHG 495-3M-...	2160-3M	720	2160	PHG 2160-3M-...
255-3M	85	255	PHG 255-3M-...	501-3M	167	501	PHG 501-3M-...	2388-3M	796	2388	PHG 2388-3M-...
264-3M	88	264	PHG 264-3M-...	510-3M	170	510	PHG 510-3M-...	2640-3M	880	2640	PHG 2640-3M-...
267-3M	89	267	PHG 267-3M-...	513-3M	171	513	PHG 513-3M-...	3000-3M	1000	3000	PHG 3000-3M-...
270-3M	90	270	PHG 270-3M-...	522-3M	174	522	PHG 522-3M-...	3210-3M	1070	3210	PHG 3210-3M-...
276-3M	92	276	PHG 276-3M-...	531-3M	177	531	PHG 531-3M-...	3390-3M	1130	3390	PHG 3390-3M-...
282-3M	94	282	PHG 282-3M-...	537-3M	179	537	PHG 537-3M-...	-	-	-	-
285-3M	95	285	PHG 285-3M-...	558-3M	186	558	PHG 558-3M-...	-	-	-	-

To complete designation add belt width in mm.

Non-standard lengths may also be available.

Full sleeves are available in various widths. Please contact your SKF Authorized Distributor.



HiTD belts

5M

- ▶ Belts
- ▶ Chains
- ▶ Couplings
- ▶ Bushings and Hubs
- ▶ Sprockets
- ▶ Pulleys
- ▶ Smart tools

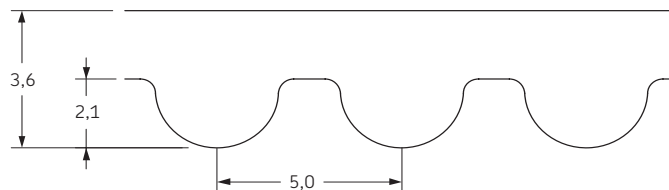

Belt marking	Number of teeth	Pitch length	Designation	Belt marking	Number of teeth	Pitch length	Designation	Belt marking	Number of teeth	Pitch length	Designation
		mm				mm				mm	
180-5M	36	180	PHG 180-5M-...	550-5M	110	550	PHG 550-5M-...	960-5M	192	960	PHG 960-5M-...
200-5M	40	200	PHG 200-5M-...	560-5M	112	560	PHG 560-5M-...	975-5M	195	975	PHG 975-5M-...
210-5M	42	210	PHG 210-5M-...	565-5M	113	565	PHG 565-5M-...	980-5M	196	980	PHG 980-5M-...
215-5M	43	215	PHG 215-5M-...	570-5M	114	570	PHG 570-5M-...	1000-5M	200	1000	PHG 1000-5M-...
225-5M	45	225	PHG 225-5M-...	575-5M	115	575	PHG 575-5M-...	1025-5M	205	1025	PHG 1025-5M-...
235-5M	47	235	PHG 235-5M-...	585-5M	117	585	PHG 585-5M-...	1050-5M	210	1050	PHG 1050-5M-...
250-5M	50	250	PHG 250-5M-...	590-5M	118	590	PHG 590-5M-...	1100-5M	220	1100	PHG 1100-5M-...
255-5M	51	255	PHG 255-5M-...	600-5M	120	600	PHG 600-5M-...	1125-5M	225	1125	PHG 1125-5M-...
265-5M	53	265	PHG 265-5M-...	610-5M	122	610	PHG 610-5M-...	1145-5M	229	1145	PHG 1145-5M-...
280-5M	56	280	PHG 280-5M-...	615-5M	123	615	PHG 615-5M-...	1175-5M	235	1175	PHG 1175-5M-...
285-5M	57	285	PHG 285-5M-...	620-5M	124	620	PHG 620-5M-...	1180-5M	236	1180	PHG 1180-5M-...
295-5M	59	295	PHG 295-5M-...	625-5M	125	625	PHG 625-5M-...	1210-5M	242	1210	PHG 1210-5M-...
300-5M	60	300	PHG 300-5M-...	630-5M	126	630	PHG 630-5M-...	1225-5M	245	1225	PHG 1225-5M-...
305-5M	61	305	PHG 305-5M-...	635-5M	127	635	PHG 635-5M-...	1270-5M	254	1270	PHG 1270-5M-...
310-5M	62	310	PHG 310-5M-...	640-5M	128	640	PHG 640-5M-...	1290-5M	258	1290	PHG 1290-5M-...
320-5M	64	320	PHG 320-5M-...	645-5M	129	645	PHG 645-5M-...	1350-5M	270	1350	PHG 1350-5M-...
325-5M	65	325	PHG 325-5M-...	650-5M	130	650	PHG 650-5M-...	1375-5M	275	1375	PHG 1375-5M-...
330-5M	66	330	PHG 330-5M-...	655-5M	131	655	PHG 655-5M-...	1400-5M	280	1400	PHG 1400-5M-...
340-5M	68	340	PHG 340-5M-...	670-5M	134	670	PHG 670-5M-...	1420-5M	284	1420	PHG 1420-5M-...
350-5M	70	350	PHG 350-5M-...	675-5M	135	675	PHG 675-5M-...	1455-5M	291	1455	PHG 1455-5M-...
365-5M	73	365	PHG 365-5M-...	690-5M	138	690	PHG 690-5M-...	1500-5M	300	1500	PHG 1500-5M-...
370-5M	74	370	PHG 370-5M-...	695-5M	139	695	PHG 695-5M-...	1595-5M	319	1595	PHG 1595-5M-...
375-5M	75	375	PHG 375-5M-...	700-5M	140	700	PHG 700-5M-...	1690-5M	338	1690	PHG 1690-5M-...
385-5M	77	385	PHG 385-5M-...	710-5M	142	710	PHG 710-5M-...	1700-5M	340	1700	PHG 1700-5M-...
395-5M	79	395	PHG 395-5M-...	715-5M	142	710	PHG 715-5M-...	1730-5M	346	1730	PHG 1730-5M-...
400-5M	80	400	PHG 400-5M-...	725-5M	145	725	PHG 725-5M-...	1790-5M	358	1790	PHG 1790-5M-...
405-5M	80	400	PHG 405-5M-...	740-5M	148	740	PHG 740-5M-...	1800-5M	360	1800	PHG 1800-5M-...
410-5M	82	410	PHG 410-5M-...	745-5M	149	745	PHG 745-5M-...	1870-5M	374	1870	PHG 1870-5M-...
420-5M	84	420	PHG 420-5M-...	750-5M	150	750	PHG 750-5M-...	1945-5M	389	1945	PHG 1945-5M-...
425-5M	85	425	PHG 425-5M-...	755-5M	151	755	PHG 755-5M-...	2000-5M	400	2000	PHG 2000-5M-...
430-5M	86	430	PHG 430-5M-...	770-5M	154	770	PHG 770-5M-...	2050-5M	410	2050	PHG 2050-5M-...
440-5M	88	440	PHG 440-5M-...	775-5M	155	775	PHG 775-5M-...	2100-5M	420	2100	PHG 2100-5M-...
445-5M	89	445	PHG 445-5M-...	790-5M	158	790	PHG 790-5M-...	2160-5M	432	2160	PHG 2160-5M-...
450-5M	90	450	PHG 450-5M-...	800-5M	160	800	PHG 800-5M-...	2250-5M	450	2250	PHG 2250-5M-...
460-5M	92	460	PHG 460-5M-...	810-5M	162	810	PHG 810-5M-...	2350-5M	470	2350	PHG 2350-5M-...
470-5M	94	470	PHG 470-5M-...	825-5M	165	825	PHG 825-5M-...	2460-5M	492	2460	PHG 2460-5M-...
475-5M	95	475	PHG 475-5M-...	830-5M	166	830	PHG 830-5M-...	2525-5M	505	2525	PHG 2525-5M-...
480-5M	96	480	PHG 480-5M-...	835-5M	167	835	PHG 835-5M-...	3060-5M	612	3060	PHG 3060-5M-...
490-5M	98	490	PHG 490-5M-...	850-5M	170	850	PHG 850-5M-...	3255-5M	651	3255	PHG 3255-5M-...
500-5M	100	500	PHG 500-5M-...	860-5M	172	860	PHG 860-5M-...	3430-5M	686	3430	PHG 3430-5M-...
505-5M	101	505	PHG 505-5M-...	890-5M	178	890	PHG 890-5M-...	3660-5M	732	3660	PHG 3660-5M-...
520-5M	104	520	PHG 520-5M-...	900-5M	180	900	PHG 900-5M-...	3750-5M	750	3750	PHG 3750-5M-...
525-5M	105	525	PHG 525-5M-...	920-5M	184	920	PHG 920-5M-...	3770-5M	754	3770	PHG 3770-5M-...
530-5M	106	530	PHG 530-5M-...	925-5M	185	925	PHG 925-5M-...	4260-5M	852	4260	PHG 4260-5M-...
535-5M	107	535	PHG 535-5M-...	935-5M	187	935	PHG 935-5M-...	5300-5M	1060	5300	PHG 5300-5M-...
540-5M	108	540	PHG 540-5M-...	950-5M	190	950	PHG 950-5M-...	7000-5M	1400	7000	PHG 7000-5M-...

To complete designation add belt width in mm.

Non-standard lengths may also be available.

Full sleeves are available in various widths. Please contact your SKF Authorized Distributor.



HiTD belts

8M

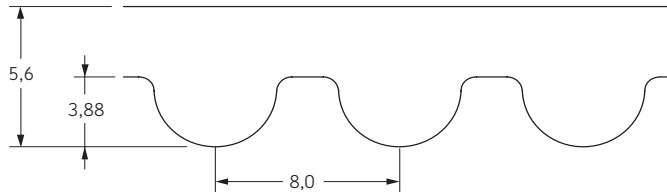

Belt marking	Number of teeth	Pitch length	Designation	Belt marking	Number of teeth	Pitch length	Designation
		mm				mm	
184-8M	23	184	PHG 184-8M-...	1248-8M	156	1248	PHG 1248-8M-...
288-8M	36	288	PHG 288-8M-...	1256-8M	157	1256	PHG 1256-8M-...
328-8M	41	328	PHG 328-8M-...	1264-8M	158	1264	PHG 1264-8M-...
336-8M	42	336	PHG 336-8M-...	1272-8M	159	1272	PHG 1272-8M-...
368-8M	46	368	PHG 368-8M-...	1280-8M	160	1280	PHG 1280-8M-...
376-8M	47	376	PHG 376-8M-...	1304-8M	163	1304	PHG 1304-8M-...
384-8M	48	384	PHG 384-8M-...	1312-8M	164	1312	PHG 1312-8M-...
400-8M	50	400	PHG 400-8M-...	1328-8M	166	1328	PHG 1328-8M-...
408-8M	51	408	PHG 408-8M-...	1344-8M	168	1344	PHG 1344-8M-...
416-8M	52	416	PHG 416-8M-...	1360-8M	170	1360	PHG 1360-8M-...
424-8M	53	424	PHG 424-8M-...	1392-8M	174	1392	PHG 1392-8M-...
440-8M	55	440	PHG 440-8M-...	1400-8M	175	1400	PHG 1400-8M-...
472-8M	59	472	PHG 472-8M-...	1424-8M	178	1424	PHG 1424-8M-...
480-8M	60	480	PHG 480-8M-...	1440-8M	180	1440	PHG 1440-8M-...
512-8M	64	512	PHG 512-8M-...	1456-8M	182	1456	PHG 1456-8M-...
520-8M	65	520	PHG 520-8M-...	1480-8M	185	1480	PHG 1480-8M-...
536-8M	67	536	PHG 536-8M-...	1512-8M	189	1512	PHG 1512-8M-...
560-8M	70	560	PHG 560-8M-...	1520-8M	190	1520	PHG 1520-8M-...
568-8M	71	568	PHG 568-8M-...	1536-8M	192	1536	PHG 1536-8M-...
576-8M	72	576	PHG 576-8M-...	1552-8M	194	1552	PHG 1552-8M-...
584-8M	73	584	PHG 584-8M-...	1576-8M	197	1576	PHG 1576-8M-...
600-8M	75	600	PHG 600-8M-...	1600-8M	200	1600	PHG 1600-8M-...
624-8M	78	624	PHG 624-8M-...	1648-8M	206	1648	PHG 1648-8M-...
632-8M	79	632	PHG 632-8M-...	1680-8M	210	1680	PHG 1680-8M-...
640-8M	80	640	PHG 640-8M-...	1696-8M	212	1696	PHG 1696-8M-...
656-8M	82	656	PHG 656-8M-...	1728-8M	216	1728	PHG 1728-8M-...
680-8M	85	680	PHG 680-8M-...	1760-8M	220	1760	PHG 1760-8M-...
688-8M	86	688	PHG 688-8M-...	1784-8M	223	1784	PHG 1784-8M-...
696-8M	87	696	PHG 696-8M-...	1792-8M	224	1792	PHG 1792-8M-...
712-8M	89	712	PHG 712-8M-...	1800-8M	225	1800	PHG 1800-8M-...
720-8M	90	720	PHG 720-8M-...	1856-8M	232	1856	PHG 1856-8M-...
728-8M	91	728	PHG 728-8M-...	1896-8M	237	1896	PHG 1896-8M-...
760-8M	95	760	PHG 760-8M-...	1904-8M	238	1904	PHG 1904-8M-...
776-8M	97	776	PHG 776-8M-...	1936-8M	242	1936	PHG 1936-8M-...
792-8M	99	792	PHG 792-8M-...	2000-8M	250	2000	PHG 2000-8M-...
800-8M	100	800	PHG 800-8M-...	2080-8M	260	2080	PHG 2080-8M-...
816-8M	102	816	PHG 816-8M-...	2096-8M	262	2096	PHG 2096-8M-...
824-8M	103	824	PHG 824-8M-...	2104-8M	263	2104	PHG 2104-8M-...
840-8M	105	840	PHG 840-8M-...	2136-8M	267	2136	PHG 2136-8M-...
856-8M	107	856	PHG 856-8M-...	2208-8M	276	2208	PHG 2208-8M-...
864-8M	108	864	PHG 864-8M-...	2240-8M	280	2240	PHG 2240-8M-...
872-8M	109	872	PHG 872-8M-...	2304-8M	288	2304	PHG 2304-8M-...
880-8M	110	880	PHG 880-8M-...	2328-8M	291	2328	PHG 2328-8M-...
896-8M	112	896	PHG 896-8M-...	2392-8M	299	2392	PHG 2392-8M-...
920-8M	115	920	PHG 920-8M-...	2400-8M	300	2400	PHG 2400-8M-...
928-8M	116	928	PHG 928-8M-...	2504-8M	313	2504	PHG 2504-8M-...
952-8M	119	952	PHG 952-8M-...	2600-8M	325	2600	PHG 2600-8M-...
960-8M	120	960	PHG 960-8M-...	2736-8M	342	2736	PHG 2736-8M-...
968-8M	121	968	PHG 968-8M-...	2800-8M	350	2800	PHG 2800-8M-...
976-8M	122	976	PHG 976-8M-...	3048-8M	381	3048	PHG 3048-8M-...
1000-8M	125	1000	PHG 1000-8M-...	3120-8M	390	3120	PHG 3120-8M-...
1016-8M	127	1016	PHG 1016-8M-...	3168-8M	396	3168	PHG 3168-8M-...
1040-8M	130	1040	PHG 1040-8M-...	3200-8M	400	3200	PHG 3200-8M-...
1056-8M	132	1056	PHG 1056-8M-...	3280-8M	410	3280	PHG 3280-8M-...
1080-8M	135	1080	PHG 1080-8M-...	3400-8M	425	3400	PHG 3400-8M-...
1104-8M	138	1104	PHG 1104-8M-...	3600-8M	450	3600	PHG 3600-8M-...
1120-8M	140	1120	PHG 1120-8M-...	4000-8M	500	4000	PHG 4000-8M-...
1128-8M	141	1128	PHG 1128-8M-...	4200-8M	525	4200	PHG 4200-8M-...
1136-8M	142	1136	PHG 1136-8M-...	4400-8M	550	4400	PHG 4400-8M-...
1152-8M	144	1152	PHG 1152-8M-...	5120-8M	640	5120	PHG 5120-8M-...
1168-8M	146	1168	PHG 1168-8M-...	5600-8M	700	5600	PHG 5600-8M-...
1184-8M	148	1184	PHG 1184-8M-...	5960-8M	745	5960	PHG 5960-8M-...
1200-8M	150	1200	PHG 1200-8M-...	6600-8M	825	6600	PHG 6600-8M-...
1216-8M	152	1216	PHG 1216-8M-...	6880-8M	860	6880	PHG 6880-8M-...

To complete designation add belt width in mm.
 Non-standard lengths may also be available.
 Full sleeves are available in various widths.
 Please contact your SKF Authorized Distributor.



HiTD belts

14M

- ▶ Belts
- ▶ Chains
- ▶ Couplings
- ▶ Bushings and Hubs
- ▶ Sprockets
- ▶ Pulleys
- ▶ Smart tools

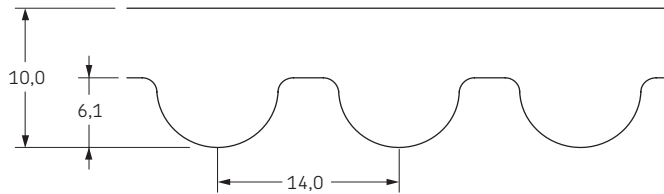

Belt marking	Number of teeth	Pitch length	Designation	Belt marking	Number of teeth	Pitch length	Designation
		mm				mm	
966-14M	69	966	PHG 966-14M-...	1820-14M	130	1820	PHG 1820-14M-...
1036-14M	74	1036	PHG 1036-14M-...	1890-14M	135	1890	PHG 1890-14M-...
1064-14M	76	1064	PHG 1064-14M-...	1932-14M	138	1932	PHG 1932-14M-...
1092-14M	78	1092	PHG 1092-14M-...	1960-14M	140	1960	PHG 1960-14M-...
1120-14M	80	1120	PHG 1120-14M-...	2002-14M	143	2002	PHG 2002-14M-...
1190-14M	85	1190	PHG 1190-14M-...	2100-14M	150	2100	PHG 2100-14M-...
1246-14M	89	1246	PHG 1246-14M-...	2240-14M	160	2240	PHG 2240-14M-...
1260-14M	90	1260	PHG 1260-14M-...	2310-14M	165	2310	PHG 2310-14M-...
1288-14M	92	1288	PHG 1288-14M-...	2450-14M	175	2450	PHG 2450-14M-...
1316-14M	94	1316	PHG 1316-14M-...	2590-14M	185	2590	PHG 2590-14M-...
1344-14M	96	1344	PHG 1344-14M-...	2800-14M	200	2800	PHG 2800-14M-...
1400-14M	100	1400	PHG 1400-14M-...	3108-14M	222	3108	PHG 3108-14M-...
1414-14M	101	1414	PHG 1414-14M-...	3150-14M	225	3150	PHG 3150-14M-...
1442-14M	103	1442	PHG 1442-14M-...	3304-14M	236	3304	PHG 3304-14M-...
1456-14M	104	1456	PHG 1456-14M-...	3360-14M	240	3360	PHG 3360-14M-...
1470-14M	105	1470	PHG 1470-14M-...	3500-14M	250	3500	PHG 3500-14M-...
1512-14M	108	1512	PHG 1512-14M-...	3850-14M	275	3850	PHG 3850-14M-...
1540-14M	110	1540	PHG 1540-14M-...	4326-14M	309	4326	PHG 4326-14M-...
1568-14M	112	1568	PHG 1568-14M-...	4578-14M	327	4578	PHG 4578-14M-...
1610-14M	115	1610	PHG 1610-14M-...	4760-14M	340	4760	PHG 4760-14M-...
1652-14M	118	1652	PHG 1652-14M-...	4956-14M	354	4956	PHG 4956-14M-...
1750-14M	125	1750	PHG 1750-14M-...	5040-14M	360	5040	PHG 5040-14M-...
1764-14M	126	1764	PHG 1764-14M-...	6160-14M	440	6160	PHG 6160-14M-...
1778-14M	127	1778	PHG 1778-14M-...	6860-14M	490	6860	PHG 6860-14M-...
1806-14M	129	1806	PHG 1806-14M-...	-	-	-	-

To complete designation add belt width in mm.

Non-standard lengths may also be available.

20M belts are also available in certain lengths

Full sleeves are available in various widths. Please contact your SKF Authorized Distributor.



Double-sided HiTD belts

D-5M

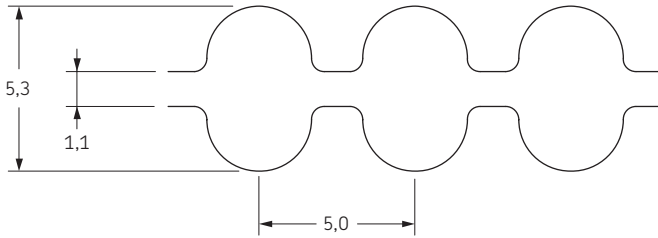

Belt marking	Number of teeth per side	Pitch length	Designation	Belt marking	Number of teeth per side	Pitch length	Designation
		mm				mm	
DA-500-5M	100	500	PHG DA-500-5M-...	DA-775-5M	155	775	PHG DA-775-5M-...
DA-505-5M	101	505	PHG DA-505-5M-...	DA-790-5M	158	790	PHG DA-790-5M-...
DA-520-5M	104	520	PHG DA-520-5M-...	DA-800-5M	160	800	PHG DA-800-5M-...
DA-525-5M	105	525	PHG DA-525-5M-...	DA-810-5M	162	810	PHG DA-810-5M-...
DA-530-5M	106	530	PHG DA-530-5M-...	DA-825-5M	165	825	PHG DA-825-5M-...
DA-535-5M	107	535	PHG DA-535-5M-...	DA-830-5M	166	830	PHG DA-830-5M-...
DA-540-5M	108	540	PHG DA-540-5M-...	DA-835-5M	167	835	PHG DA-835-5M-...
DA-550-5M	110	550	PHG DA-550-5M-...	DA-850-5M	170	850	PHG DA-850-5M-...
DA-560-5M	112	560	PHG DA-560-5M-...	DA-860-5M	172	860	PHG DA-860-5M-...
DA-565-5M	113	565	PHG DA-565-5M-...	DA-890-5M	178	890	PHG DA-890-5M-...
DA-570-5M	114	570	PHG DA-570-5M-...	DA-900-5M	180	900	PHG DA-900-5M-...
DA-575-5M	115	575	PHG DA-575-5M-...	DA-920-5M	184	920	PHG DA-920-5M-...
DA-585-5M	117	585	PHG DA-585-5M-...	DA-925-5M	185	925	PHG DA-925-5M-...
DA-590-5M	118	590	PHG DA-590-5M-...	DA-935-5M	187	935	PHG DA-935-5M-...
DA-600-5M	120	600	PHG DA-600-5M-...	DA-950-5M	190	950	PHG DA-950-5M-...
DA-610-5M	122	610	PHG DA-610-5M-...	DA-960-5M	192	960	PHG DA-960-5M-...
DA-615-5M	123	615	PHG DA-615-5M-...	DA-975-5M	195	975	PHG DA-975-5M-...
DA-620-5M	124	620	PHG DA-620-5M-...	DA-980-5M	195	975	PHG DA-980-5M-...
DA-625-5M	125	625	PHG DA-625-5M-...	DA-1000-5M	200	1000	PHG DA-1000-5M-...
DA-630-5M	126	630	PHG DA-630-5M-...	DA-1025-5M	205	1025	PHG DA-1025-5M-...
DA-635-5M	127	635	PHG DA-635-5M-...	DA-1050-5M	210	1050	PHG DA-1050-5M-...
DA-640-5M	128	640	PHG DA-640-5M-...	DA-1100-5M	220	1100	PHG DA-1100-5M-...
DA-645-5M	129	645	PHG DA-645-5M-...	DA-1125-5M	225	1125	PHG DA-1125-5M-...
DA-650-5M	130	650	PHG DA-650-5M-...	DA-1145-5M	229	1145	PHG DA-1145-5M-...
DA-655-5M	131	655	PHG DA-655-5M-...	DA-1175-5M	235	1175	PHG DA-1175-5M-...
DA-670-5M	134	670	PHG DA-670-5M-...	DA-1180-5M	236	1180	PHG DA-1180-5M-...
DA-675-5M	135	675	PHG DA-675-5M-...	DA-1210-5M	242	1210	PHG DA-1210-5M-...
DA-690-5M	138	690	PHG DA-690-5M-...	DA-1225-5M	245	1225	PHG DA-1225-5M-...
DA-695-5M	139	695	PHG DA-695-5M-...	DA-1270-5M	254	1270	PHG DA-1270-5M-...
DA-700-5M	140	700	PHG DA-700-5M-...	DA-1290-5M	258	1290	PHG DA-1290-5M-...
DA-715-5M	142	710	PHG DA-715-5M-...	DA-1350-5M	270	1350	PHG DA-1350-5M-...
DA-710-5M	142	710	PHG DA-710-5M-...	DA-1375-5M	275	1375	PHG DA-1375-5M-...
DA-725-5M	145	725	PHG DA-725-5M-...	DA-1400-5M	280	1400	PHG DA-1400-5M-...
DA-740-5M	148	740	PHG DA-740-5M-...	DA-1420-5M	284	1420	PHG DA-1420-5M-...
DA-745-5M	149	745	PHG DA-745-5M-...	DA-1455-5M	291	1455	PHG DA-1455-5M-...
DA-750-5M	150	750	PHG DA-750-5M-...	DA-1500-5M	300	1500	PHG DA-1500-5M-...
DA-755-5M	151	755	PHG DA-755-5M-...	DA-1595-5M	319	1595	PHG DA-1595-5M-...
DA-770-5M	154	770	PHG DA-770-5M-...	DA-1690-5M	338	1690	PHG DA-1690-5M-...

To complete designation add belt width in mm.

Non-standard lengths may also be available.

Double-sided HiTD belts are available in symmetric (DA) only.

Full sleeves are available in various widths. Please contact your SKF Authorized Distributor.



Double-sided HiTD belts

D-8M

- ▶ Belts
- ▶ Chains
- ▶ Couplings
- ▶ Bushings and Hubs
- ▶ Sprockets
- ▶ Pulleys
- ▶ Smart tools

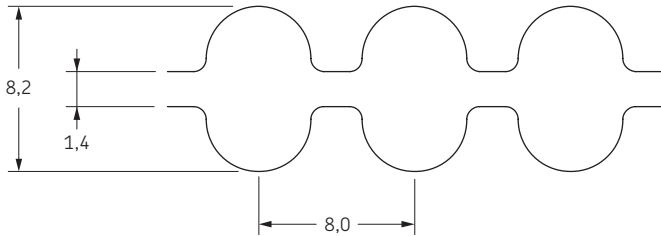

Belt marking	Number of teeth per side	Pitch length	Designation	Belt marking	Number of teeth per side	Pitch length	Designation
		mm				mm	
DA-512-8M	64	512	PHG DA-512-8M-...	DA-1328-8M	166	1328	PHG DA-1328-8M-...
DA-520-8M	65	520	PHG DA-520-8M-...	DA-1344-8M	168	1344	PHG DA-1344-8M-...
DA-536-8M	67	536	PHG DA-536-8M-...	DA-1360-8M	170	1360	PHG DA-1360-8M-...
DA-560-8M	70	560	PHG DA-560-8M-...	DA-1392-8M	174	1392	PHG DA-1392-8M-...
DA-568-8M	71	568	PHG DA-568-8M-...	DA-1400-8M	175	1400	PHG DA-1400-8M-...
DA-576-8M	72	576	PHG DA-576-8M-...	DA-1424-8M	178	1424	PHG DA-1424-8M-...
DA-584-8M	73	584	PHG DA-584-8M-...	DA-1440-8M	180	1440	PHG DA-1440-8M-...
DA-600-8M	75	600	PHG DA-600-8M-...	DA-1456-8M	182	1456	PHG DA-1456-8M-...
DA-624-8M	78	624	PHG DA-624-8M-...	DA-1480-8M	185	1480	PHG DA-1480-8M-...
DA-632-8M	79	632	PHG DA-632-8M-...	DA-1512-8M	189	1512	PHG DA-1512-8M-...
DA-640-8M	80	640	PHG DA-640-8M-...	DA-1520-8M	190	1520	PHG DA-1520-8M-...
DA-656-8M	82	656	PHG DA-656-8M-...	DA-1536-8M	192	1536	PHG DA-1536-8M-...
DA-680-8M	85	680	PHG DA-680-8M-...	DA-1552-8M	194	1552	PHG DA-1552-8M-...
DA-688-8M	86	688	PHG DA-688-8M-...	DA-1576-8M	197	1576	PHG DA-1576-8M-...
DA-696-8M	87	696	PHG DA-696-8M-...	DA-1600-8M	200	1600	PHG DA-1600-8M-...
DA-712-8M	89	712	PHG DA-712-8M-...	DA-1648-8M	206	1648	PHG DA-1648-8M-...
DA-720-8M	90	720	PHG DA-720-8M-...	DA-1680-8M	210	1680	PHG DA-1680-8M-...
DA-728-8M	91	728	PHG DA-728-8M-...	DA-1696-8M	212	1696	PHG DA-1696-8M-...
DA-760-8M	95	760	PHG DA-760-8M-...	DA-1728-8M	216	1728	PHG DA-1728-8M-...
DA-776-8M	97	776	PHG DA-776-8M-...	DA-1760-8M	220	1760	PHG DA-1760-8M-...
DA-792-8M	99	792	PHG DA-792-8M-...	DA-1784-8M	223	1784	PHG DA-1784-8M-...
DA-800-8M	100	800	PHG DA-800-8M-...	DA-1792-8M	224	1792	PHG DA-1792-8M-...
DA-816-8M	102	816	PHG DA-816-8M-...	DA-1800-8M	225	1800	PHG DA-1800-8M-...
DA-824-8M	103	824	PHG DA-824-8M-...	DA-1856-8M	232	1856	PHG DA-1856-8M-...
DA-840-8M	105	840	PHG DA-840-8M-...	DA-1896-8M	237	1896	PHG DA-1896-8M-...
DA-856-8M	107	856	PHG DA-856-8M-...	DA-1904-8M	238	1904	PHG DA-1904-8M-...
DA-864-8M	108	864	PHG DA-864-8M-...	DA-1936-8M	242	1936	PHG DA-1936-8M-...
DA-872-8M	109	872	PHG DA-872-8M-...	DA-2000-8M	250	2000	PHG DA-2000-8M-...
DA-880-8M	110	880	PHG DA-880-8M-...	DA-2080-8M	260	2080	PHG DA-2080-8M-...
DA-896-8M	112	896	PHG DA-896-8M-...	DA-2096-8M	262	2096	PHG DA-2096-8M-...
DA-920-8M	115	920	PHG DA-920-8M-...	DA-2104-8M	263	2104	PHG DA-2104-8M-...
DA-928-8M	116	928	PHG DA-928-8M-...	DA-2136-8M	267	2136	PHG DA-2136-8M-...
DA-952-8M	119	952	PHG DA-952-8M-...	DA-2208-8M	276	2208	PHG DA-2208-8M-...
DA-960-8M	120	960	PHG DA-960-8M-...	DA-2240-8M	280	2240	PHG DA-2240-8M-...
DA-968-8M	121	968	PHG DA-968-8M-...	DA-2304-8M	288	2304	PHG DA-2304-8M-...
DA-976-8M	122	976	PHG DA-976-8M-...	DA-2328-8M	291	2328	PHG DA-2328-8M-...
DA-1000-8M	125	1000	PHG DA-1000-8M-...	DA-2392-8M	299	2392	PHG DA-2392-8M-...
DA-1016-8M	127	1016	PHG DA-1016-8M-...	DA-2400-8M	300	2400	PHG DA-2400-8M-...
DA-1040-8M	130	1040	PHG DA-1040-8M-...	DA-2504-8M	313	2504	PHG DA-2504-8M-...
DA-1056-8M	132	1056	PHG DA-1056-8M-...	DA-2600-8M	325	2600	PHG DA-2600-8M-...
DA-1080-8M	135	1080	PHG DA-1080-8M-...	DA-2736-8M	342	2736	PHG DA-2736-8M-...
DA-1104-8M	138	1104	PHG DA-1104-8M-...	DA-2800-8M	350	2800	PHG DA-2800-8M-...
DA-1120-8M	140	1120	PHG DA-1120-8M-...	DA-3048-8M	381	3048	PHG DA-3048-8M-...
DA-1128-8M	141	1128	PHG DA-1128-8M-...	DA-3120-8M	390	3120	PHG DA-3120-8M-...
DA-1136-8M	142	1136	PHG DA-1136-8M-...	DA-3168-8M	396	3168	PHG DA-3168-8M-...
DA-1152-8M	144	1152	PHG DA-1152-8M-...	DA-3200-8M	400	3200	PHG DA-3200-8M-...
DA-1168-8M	146	1168	PHG DA-1168-8M-...	DA-3280-8M	410	3280	PHG DA-3280-8M-...
DA-1184-8M	148	1184	PHG DA-1184-8M-...	DA-3400-8M	425	3400	PHG DA-3400-8M-...
DA-1200-8M	150	1200	PHG DA-1200-8M-...	DA-3600-8M	450	3600	PHG DA-3600-8M-...
DA-1216-8M	152	1216	PHG DA-1216-8M-...	DA-4000-8M	500	4000	PHG DA-4000-8M-...
DA-1248-8M	156	1248	PHG DA-1248-8M-...	DA-4200-8M	525	4200	PHG DA-4200-8M-...
DA-1256-8M	157	1256	PHG DA-1256-8M-...	DA-4400-8M	550	4400	PHG DA-4400-8M-...
DA-1264-8M	158	1264	PHG DA-1264-8M-...	DA-5120-8M	640	5120	PHG DA-5120-8M-...
DA-1272-8M	159	1272	PHG DA-1272-8M-...	DA-5600-8M	700	5600	PHG DA-5600-8M-...
DA-1280-8M	160	1280	PHG DA-1280-8M-...	DA-5960-8M	745	5960	PHG DA-5960-8M-...
DA-1304-8M	163	1304	PHG DA-1304-8M-...	DA-6600-8M	825	6600	PHG DA-6600-8M-...
DA-1312-8M	164	1312	PHG DA-1312-8M-...	DA-6880-8M	860	6880	PHG DA-6880-8M-...

To complete designation add belt width in mm.

Non-standard lengths may also be available.

Double-sided HiTD belts are available in symmetric (DA) only.

Full sleeves are available in various widths. Please contact your SKF Authorized Distributor.



Double-sided HiTD belts

D-14M

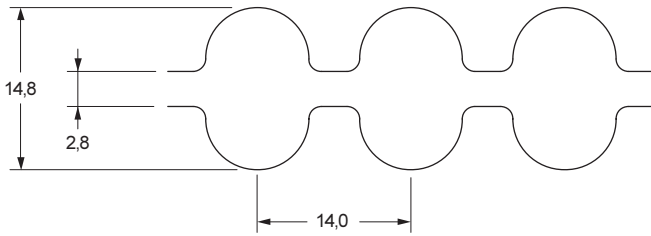

Belt marking	Number of teeth per side	Pitch length	Designation	Belt marking	Number of teeth per side	Pitch length	Designation
		mm				mm	
DA-1750-14M	125	1750	PHG DA-1750-14M-...	DA-2800-14M	200	2800	PHG DA-2800-14M-...
DA-1764-14M	126	1764	PHG DA-1764-14M-...	DA-3108-14M	222	3108	PHG DA-3108-14M-...
DA-1778-14M	127	1778	PHG DA-1778-14M-...	DA-3150-14M	225	3150	PHG DA-3150-14M-...
DA-1806-14M	129	1806	PHG DA-1806-14M-...	DA-3304-14M	236	3304	PHG DA-3304-14M-...
DA-1820-14M	130	1820	PHG DA-1820-14M-...	DA-3360-14M	240	3360	PHG DA-3360-14M-...
DA-1890-14M	135	1890	PHG DA-1890-14M-...	DA-3500-14M	250	3500	PHG DA-3500-14M-...
DA-1932-14M	138	1932	PHG DA-1932-14M-...	DA-3850-14M	275	3850	PHG DA-3850-14M-...
DA-1960-14M	140	1960	PHG DA-1960-14M-...	DA-4326-14M	309	4326	PHG DA-4326-14M-...
DA-2002-14M	143	2002	PHG DA-2002-14M-...	DA-4578-14M	327	4578	PHG DA-4578-14M-...
DA-2100-14M	150	2100	PHG DA-2100-14M-...	DA-4760-14M	340	4760	PHG DA-4760-14M-...
DA-2240-14M	160	2240	PHG DA-2240-14M-...	DA-4956-14M	354	4956	PHG DA-4956-14M-...
DA-2310-14M	165	2310	PHG DA-2310-14M-...	DA-5040-14M	360	5040	PHG DA-5040-14M-...
DA-2450-14M	175	2450	PHG DA-2450-14M-...	DA-6160-14M	440	6160	PHG DA-6160-14M-...
DA-2590-14M	185	2590	PHG DA-2590-14M-...	DA-6860-14M	490	6860	PHG DA-6860-14M-...

To complete designation add belt width in mm.

Non-standard lengths may also be available.

Double-sided HiTD belts are available in symmetric (DA) only.

Full sleeves are available in various widths. Please contact your SKF Authorized Distributor.

For polyurethane version, add "PU" to the profile type. For example: PHG T5PU-1000...

Metric timing belts

T2.5

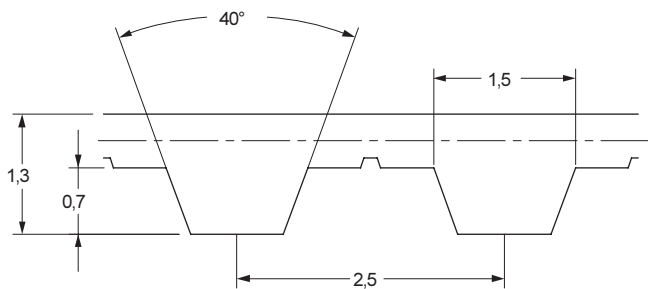
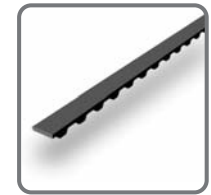

Belt marking	Number of teeth	Pitch length	Designation	Belt marking	Number of teeth	Pitch length	Designation
		mm				mm	
T2,5-102,5	41	102,5	PHG T2,5-102,5-...	T2,5-420	168	420,0	PHG T2,5-420-...
T2,5-120	48	120,0	PHG T2,5-120-...	T2,5-470	188	470,0	PHG T2,5-470-...
T2,5-145	58	145,0	PHG T2,5-145-...	T2,5-480	192	480,0	PHG T2,5-480-...
T2,5-150	60	150,0	PHG T2,5-150-...	T2,5-500	200	500,0	PHG T2,5-500-...
T2,5-160	64	160,0	PHG T2,5-160-...	T2,5-540	216	540,0	PHG T2,5-540-...
T2,5-165	66	165,0	PHG T2,5-165-...	T2,5-620	248	620,0	PHG T2,5-620-...
T2,5-177,5	71	177,5	PHG T2,5-177,5-...	T2,5-635	254	635,0	PHG T2,5-635-...
T2,5-187,5	75	187,5	PHG T2,5-187,5-...	T2,5-690	276	690,0	PHG T2,5-690-...
T2,5-200	80	200,0	PHG T2,5-200-...	T2,5-705	282	705,0	PHG T2,5-705-...
T2,5-230	92	230,0	PHG T2,5-230-...	T2,5-787,5	315	787,5	PHG T2,5-787,5-...
T2,5-245	98	245,0	PHG T2,5-245-...	T2,5-905	362	905,0	PHG T2,5-905-...
T2,5-265	106	265,0	PHG T2,5-265-...	T2,5-975	390	975,0	PHG T2,5-975-...
T2,5-285	114	285,0	PHG T2,5-285-...	T2,5-1040	416	1040,0	PHG T2,5-1040-...
T2,5-300	120	300,0	PHG T2,5-300-...	T2,5-1090	436	1090,0	PHG T2,5-1090-...
T2,5-317,5	127	317,5	PHG T2,5-317,5-...	T2,5-1095	438	1095,0	PHG T2,5-1095-...
T2,5-330	132	330,0	PHG T2,5-330-...	T2,5-1127,5	451	1127,5	PHG T2,5-1127,5-...
T2,5-335	134	335,0	PHG T2,5-335-...	T2,5-1295	518	1295,0	PHG T2,5-1295-...
T2,5-380	152	380,0	PHG T2,5-380-...	T2,5-1345	538	1345,0	PHG T2,5-1345-...
T2,5-410	164	410,0	PHG T2,5-410-...	-	-	-	-

To complete designation add belt width in mm.

Non-standard lengths may also be available.

Full sleeves are available in various widths. Please contact your SKF Authorized Distributor.

For polyurethane version, add "PU" to the profile type. For example: PHG T5PU-1000...



Metric timing belts

T5

- ▶ Belts
- ▶ Chains
- ▶ Couplings
- ▶ Bushings and Hubs
- ▶ Sprockets
- ▶ Pulleys
- ▶ Smart tools

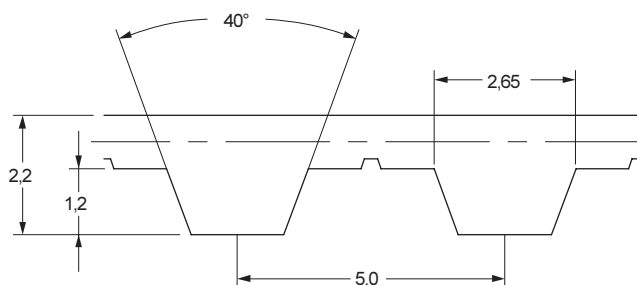

Belt marking	Number of teeth	Pitch length	Designation	Belt marking	Number of teeth	Pitch length	Designation
		mm				mm	
T5-115	23	115	PHG T5-115-...	T5-690	138	690	PHG T5-690-...
T5-150	30	150	PHG T5-150-...	T5-700	140	700	PHG T5-700-...
T5-165	33	165	PHG T5-165-...	T5-710	142	710	PHG T5-710-...
T5-185	37	185	PHG T5-185-...	T5-720	144	720	PHG T5-720-...
T5-200	40	200	PHG T5-200-...	T5-725	145	725	PHG T5-725-...
T5-210	42	210	PHG T5-210-...	T5-740	148	740	PHG T5-740-...
T5-215	43	215	PHG T5-215-...	T5-750	150	750	PHG T5-750-...
T5-220	44	220	PHG T5-220-...	T5-780	156	780	PHG T5-780-...
T5-225	45	225	PHG T5-225-...	T5-800	160	800	PHG T5-800-...
T5-240	48	240	PHG T5-240-...	T5-805	161	805	PHG T5-805-...
T5-250	50	250	PHG T5-250-...	T5-810	162	810	PHG T5-810-...
T5-255	51	255	PHG T5-255-...	T5-815	163	815	PHG T5-815-...
T5-260	52	260	PHG T5-260-...	T5-850	170	850	PHG T5-850-...
T5-275	55	275	PHG T5-275-...	T5-860	172	860	PHG T5-860-...
T5-280	56	280	PHG T5-280-...	T5-900	180	900	PHG T5-900-...
T5-295	59	295	PHG T5-295-...	T5-940	188	940	PHG T5-940-...
T5-300	60	300	PHG T5-300-...	T5-990	198	990	PHG T5-990-...
T5-305	61	305	PHG T5-305-...	T5-995	199	995	PHG T5-995-...
T5-310	62	310	PHG T5-310-...	T5-1000	200	1000	PHG T5-1000-...
T5-325	65	325	PHG T5-325-...	T5-1020	204	1020	PHG T5-1020-...
T5-330	66	330	PHG T5-330-...	T5-1030	206	1030	PHG T5-1030-...
T5-340	68	340	PHG T5-340-...	T5-1045	209	1045	PHG T5-1045-...
T5-350	70	350	PHG T5-350-...	T5-1050	210	1050	PHG T5-1050-...
T5-355	71	355	PHG T5-355-...	T5-1060	212	1060	PHG T5-1060-...
T5-365	73	365	PHG T5-365-...	T5-1075	215	1075	PHG T5-1075-...
T5-375	75	375	PHG T5-375-...	T5-1100	220	1100	PHG T5-1100-...
T5-390	78	390	PHG T5-390-...	T5-1120	224	1120	PHG T5-1120-...
T5-400	80	400	PHG T5-400-...	T5-1140	228	1140	PHG T5-1140-...
T5-410	82	410	PHG T5-410-...	T5-1200	240	1200	PHG T5-1200-...
T5-420	84	420	PHG T5-420-...	T5-1215	243	1215	PHG T5-1215-...
T5-450	90	450	PHG T5-450-...	T5-1260	252	1260	PHG T5-1260-...
T5-455	91	455	PHG T5-455-...	T5-1300	260	1300	PHG T5-1300-...
T5-475	95	475	PHG T5-475-...	T5-1380	276	1380	PHG T5-1380-...
T5-480	96	480	PHG T5-480-...	T5-1390	278	1390	PHG T5-1390-...
T5-500	100	500	PHG T5-500-...	T5-1415	283	1415	PHG T5-1415-...
T5-505	101	505	PHG T5-505-...	T5-1520	304	1520	PHG T5-1520-...
T5-510	102	510	PHG T5-510-...	T5-1760	352	1760	PHG T5-1760-...
T5-525	105	525	PHG T5-525-...	T5-1800	360	1800	PHG T5-1800-...
T5-545	109	545	PHG T5-545-...	T5-1880	376	1880	PHG T5-1880-...
T5-550	110	550	PHG T5-550-...	T5-1900	380	1900	PHG T5-1900-...
T5-560	112	560	PHG T5-560-...	T5-1940	388	1940	PHG T5-1940-...
T5-570	114	570	PHG T5-570-...	T5-1960	392	1960	PHG T5-1960-...
T5-575	115	575	PHG T5-575-...	T5-2120	424	2120	PHG T5-2120-...
T5-600	120	600	PHG T5-600-...	T5-2160	432	2160	PHG T5-2160-...
T5-610	122	610	PHG T5-610-...	T5-2220	444	2220	PHG T5-2220-...
T5-620	124	620	PHG T5-620-...	T5-2260	452	2260	PHG T5-2260-...
T5-630	126	630	PHG T5-630-...	T5-2280	456	2280	PHG T5-2280-...
T5-635	127	635	PHG T5-635-...	T5-3060	612	3060	PHG T5-3060-...
T5-650	130	650	PHG T5-650-...	T5-3255	651	3255	PHG T5-3255-...
T5-665	133	665	PHG T5-665-...	T5-3540	708	3540	PHG T5-3540-...
T5-675	135	675	PHG T5-675-...	T5-3750	750	3750	PHG T5-3750-...
T5-685	137	685	PHG T5-685-...	T5-4075	815	4075	PHG T5-4075-...

To complete designation add belt width in mm.

Non-standard lengths may also be available.

Full sleeves are available in various widths. Please contact your SKF Authorized Distributor.

For polyurethane version, add "PU" to the profile type. For example: PHG T5PU-1000...



Metric timing belts

T10

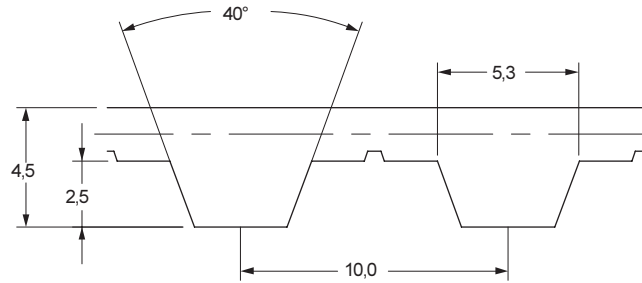

Belt marking	Number of teeth	Pitch length	Designation	Belt marking	Number of teeth	Pitch length	Designation
		mm				mm	
T10-260	26	260	PHG T10-260-...	T10-1420	142	1420	PHG T10-1420-...
T10-320	32	320	PHG T10-320-...	T10-1440	144	1440	PHG T10-1440-...
T10-340	34	340	PHG T10-340-...	T10-1450	145	1450	PHG T10-1450-...
T10-370	37	370	PHG T10-370-...	T10-1460	146	1460	PHG T10-1460-...
T10-400	40	400	PHG T10-400-...	T10-1480	148	1480	PHG T10-1480-...
T10-410	41	410	PHG T10-410-...	T10-1500	150	1500	PHG T10-1500-...
T10-440	44	440	PHG T10-440-...	T10-1520	152	1520	PHG T10-1520-...
T10-450	45	450	PHG T10-450-...	T10-1560	156	1560	PHG T10-1560-...
T10-460	46	460	PHG T10-460-...	T10-1600	160	1600	PHG T10-1600-...
T10-480	48	480	PHG T10-480-...	T10-1610	161	1610	PHG T10-1610-...
T10-500	50	500	PHG T10-500-...	T10-1640	164	1640	PHG T10-1640-...
T10-530	53	530	PHG T10-530-...	T10-1690	169	1690	PHG T10-1690-...
T10-540	54	540	PHG T10-540-...	T10-1700	170	1700	PHG T10-1700-...
T10-550	55	550	PHG T10-550-...	T10-1750	175	1750	PHG T10-1750-...
T10-560	56	560	PHG T10-560-...	T10-1780	178	1780	PHG T10-1780-...
T10-580	58	580	PHG T10-580-...	T10-1800	180	1800	PHG T10-1800-...
T10-600	60	600	PHG T10-600-...	T10-1860	186	1860	PHG T10-1860-...
T10-610	61	610	PHG T10-610-...	T10-1880	188	1880	PHG T10-1880-...
T10-630	63	630	PHG T10-630-...	T10-1960	196	1960	PHG T10-1960-...
T10-650	65	650	PHG T10-650-...	T10-1980	198	1980	PHG T10-1980-...
T10-660	66	660	PHG T10-660-...	T10-2020	202	2020	PHG T10-2020-...
T10-700	70	700	PHG T10-700-...	T10-2080	208	2080	PHG T10-2080-...
T10-720	72	720	PHG T10-720-...	T10-2090	209	2090	PHG T10-2090-...
T10-730	73	730	PHG T10-730-...	T10-2100	210	2100	PHG T10-2100-...
T10-750	75	750	PHG T10-750-...	T10-2200	220	2200	PHG T10-2200-...
T10-770	77	770	PHG T10-770-...	T10-2250	225	2250	PHG T10-2250-...
T10-780	78	780	PHG T10-780-...	T10-2270	227	2270	PHG T10-2270-...
T10-800	80	800	PHG T10-800-...	T10-2300	230	2300	PHG T10-2300-...
T10-810	81	810	PHG T10-810-...	T10-2340	234	2340	PHG T10-2340-...
T10-840	84	840	PHG T10-840-...	T10-2360	236	2360	PHG T10-2360-...
T10-850	85	850	PHG T10-850-...	T10-2380	238	2380	PHG T10-2380-...
T10-880	88	880	PHG T10-880-...	T10-2430	243	2430	PHG T10-2430-...
T10-890	89	890	PHG T10-890-...	T10-2480	248	2480	PHG T10-2480-...
T10-900	90	900	PHG T10-900-...	T10-2500	250	2500	PHG T10-2500-...
T10-910	91	910	PHG T10-910-...	T10-2540	254	2540	PHG T10-2540-...
T10-920	92	920	PHG T10-920-...	T10-2590	259	2590	PHG T10-2590-...
T10-950	95	950	PHG T10-950-...	T10-2610	261	2610	PHG T10-2610-...
T10-960	96	960	PHG T10-960-...	T10-2650	265	2650	PHG T10-2650-...
T10-970	97	970	PHG T10-970-...	T10-2800	280	2800	PHG T10-2800-...
T10-980	98	980	PHG T10-980-...	T10-2880	288	2880	PHG T10-2880-...
T10-1000	100	1000	PHG T10-1000-...	T10-3000	300	3000	PHG T10-3000-...
T10-1010	101	1010	PHG T10-1010-...	T10-3040	304	3040	PHG T10-3040-...
T10-1040	104	1040	PHG T10-1040-...	T10-3100	310	3100	PHG T10-3100-...
T10-1050	105	1050	PHG T10-1050-...	T10-3230	323	3230	PHG T10-3230-...
T10-1080	108	1080	PHG T10-1080-...	T10-3300	330	3300	PHG T10-3300-...
T10-1100	110	1100	PHG T10-1100-...	T10-3340	334	3340	PHG T10-3340-...
T10-1110	111	1110	PHG T10-1110-...	T10-3500	350	3500	PHG T10-3500-...
T10-1140	114	1140	PHG T10-1140-...	T10-3600	360	3600	PHG T10-3600-...
T10-1150	115	1150	PHG T10-1150-...	T10-3680	368	3680	PHG T10-3680-...
T10-1200	120	1200	PHG T10-1200-...	T10-3870	387	3870	PHG T10-3870-...
T10-1210	121	1210	PHG T10-1210-...	T10-4040	404	4040	PHG T10-4040-...
T10-1240	124	1240	PHG T10-1240-...	T10-4280	428	4280	PHG T10-4280-...
T10-1250	125	1250	PHG T10-1250-...	T10-4680	468	4680	PHG T10-4680-...
T10-1260	126	1260	PHG T10-1260-...	T10-5060	506	5060	PHG T10-5060-...
T10-1280	128	1280	PHG T10-1280-...	T10-5360	536	5360	PHG T10-5360-...
T10-1300	130	1300	PHG T10-1300-...	T10-5670	567	5670	PHG T10-5670-...
T10-1320	132	1320	PHG T10-1320-...	T10-6000	600	6000	PHG T10-6000-...
T10-1350	135	1350	PHG T10-1350-...	T10-6290	629	6290	PHG T10-6290-...
T10-1390	139	1390	PHG T10-1390-...	T10-7000	700	7000	PHG T10-7000-...
T10-1400	140	1400	PHG T10-1400-...	T10-7050	705	7050	PHG T10-7050-...

To complete designation add belt width in mm.

Non-standard lengths may also be available.

Full sleeves are available in various widths. Please contact your SKF Authorized Distributor.

For polyurethane version, add "PU" to the profile type.

For example: PHG T5PU-1000...



Metric timing belts

T20

- ▶ Belts
- ▶ Chains
- ▶ Couplings
- ▶ Bushings and Hubs
- ▶ Sprockets
- ▶ Pulleys
- ▶ Smart tools

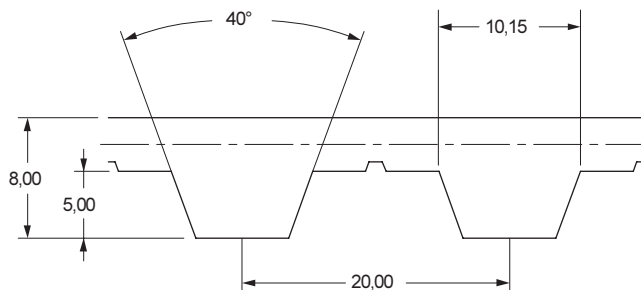

Belt marking	Number of teeth	Pitch length	Designation
		mm	
T20-1180	59	1180	PHG T20-1180-...
T20-1220	61	1220	PHG T20-1220-...
T20-1240	62	1240	PHG T20-1240-...
T20-1260	63	1260	PHG T20-1260-...
T20-1280	64	1280	PHG T20-1280-...
T20-1460	73	1460	PHG T20-1460-...
T20-1700	85	1700	PHG T20-1700-...
T20-1780	89	1780	PHG T20-1780-...
T20-1880	94	1880	PHG T20-1880-...
T20-1680	94	1880	PHG T20-1680-...
T20-2040	102	2040	PHG T20-2040-...
T20-2200	110	2200	PHG T20-2200-...
T20-2240	112	2240	PHG T20-2240-...
T20-2600	130	2600	PHG T20-2600-...
T20-2720	136	2720	PHG T20-2720-...
T20-2740	137	2740	PHG T20-2740-...
T20-2760	138	2760	PHG T20-2760-...
T20-3100	155	3100	PHG T20-3100-...
T20-3620	181	3620	PHG T20-3620-...
T20-4760	238	4760	PHG T20-4760-...
T20-5000	250	5000	PHG T20-5000-...

To complete designation add belt width in mm.

Non-standard lengths may also be available.

Full sleeves are available in various widths. Please contact your SKF Authorized Distributor.

For polyurethane version, add "PU" to the profile type. For example: PHG T5PU-1000...



Double-sided metric timing belts

D-T5

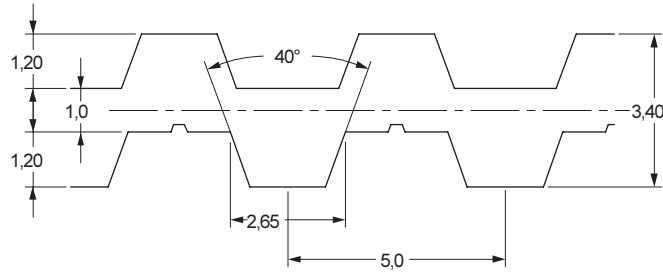
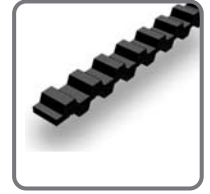

Belt marking	Number of teeth per side	Pitch length	Designation	Belt marking	Number of teeth per side	Pitch length	Designation
		mm				mm	
D...-T5-500	100	500	PHG D...-T5-500-...	D...-T5-805	161	805	PHG D...-T5-805-...
D...-T5-505	101	505	PHG D...-T5-505-...	D...-T5-810	162	810	PHG D...-T5-810-...
D...-T5-510	102	510	PHG D...-T5-510-...	D...-T5-815	163	815	PHG D...-T5-815-...
D...-T5-525	105	525	PHG D...-T5-525-...	D...-T5-840	168	840	PHG D...-T5-840-...
D...-T5-545	109	545	PHG D...-T5-545-...	D...-T5-850	170	850	PHG D...-T5-850-...
D...-T5-550	110	550	PHG D...-T5-550-...	D...-T5-860	172	860	PHG D...-T5-860-...
D...-T5-560	112	560	PHG D...-T5-560-...	D...-T5-900	180	900	PHG D...-T5-900-...
D...-T5-570	114	570	PHG D...-T5-570-...	D...-T5-940	188	940	PHG D...-T5-940-...
D...-T5-575	115	575	PHG D...-T5-575-...	D...-T5-990	198	990	PHG D...-T5-990-...
D...-T5-600	120	600	PHG D...-T5-600-...	D...-T5-995	199	995	PHG D...-T5-995-...
D...-T5-610	122	610	PHG D...-T5-610-...	D...-T5-1000	200	1000	PHG D...-T5-1000-...
D...-T5-620	124	620	PHG D...-T5-620-...	D...-T5-1020	204	1020	PHG D...-T5-1020-...
D...-T5-630	126	630	PHG D...-T5-630-...	D...-T5-1030	206	1030	PHG D...-T5-1030-...
D...-T5-635	127	635	PHG D...-T5-635-...	D...-T5-1045	209	1045	PHG D...-T5-1045-...
D...-T5-650	130	650	PHG D...-T5-650-...	D...-T5-1050	210	1050	PHG D...-T5-1050-...
D...-T5-665	133	665	PHG D...-T5-665-...	D...-T5-1060	212	1060	PHG D...-T5-1060-...
D...-T5-675	135	675	PHG D...-T5-675-...	D...-T5-1075	215	1075	PHG D...-T5-1075-...
D...-T5-685	137	685	PHG D...-T5-685-...	D...-T5-1100	220	1100	PHG D...-T5-1100-...
D...-T5-690	138	690	PHG D...-T5-690-...	D...-T5-1120	224	1120	PHG D...-T5-1120-...
D...-T5-700	140	700	PHG D...-T5-700-...	D...-T5-1140	228	1140	PHG D...-T5-1140-...
D...-T5-710	142	710	PHG D...-T5-710-...	D...-T5-1200	240	1200	PHG D...-T5-1200-...
D...-T5-720	144	720	PHG D...-T5-720-...	D...-T5-1215	243	1215	PHG D...-T5-1215-...
D...-T5-725	145	725	PHG D...-T5-725-...	D...-T5-1260	252	1260	PHG D...-T5-1260-...
D...-T5-740	148	740	PHG D...-T5-740-...	D...-T5-1300	260	1300	PHG D...-T5-1300-...
D...-T5-750	150	750	PHG D...-T5-750-...	D...-T5-1380	276	1380	PHG D...-T5-1380-...
D...-T5-780	156	780	PHG D...-T5-780-...	D...-T5-1390	278	1390	PHG D...-T5-1390-...
D...-T5-800	160	800	PHG D...-T5-800-...	D...-T5-1415	283	1415	PHG D...-T5-1415-...

To complete designation add belt width in mm.

Non-standard lengths may also be available.

Double sided Metric belts are available in symmetric (DA) and asymmetric (DB) tooth profiles.

Symmetric will supplied unless otherwise specified

Full sleeves are available in various widths. Please contact your SKF Authorized Distributor.

For polyurethane version, add "PU" to the profile type. For example: PHG T5PU-1000...



Double-sided metric timing belts

D-T10

- ▶ Belts
- ▶ Chains
- ▶ Couplings
- ▶ Bushings and Hubs
- ▶ Sprockets
- ▶ Pulleys
- ▶ Smart tools

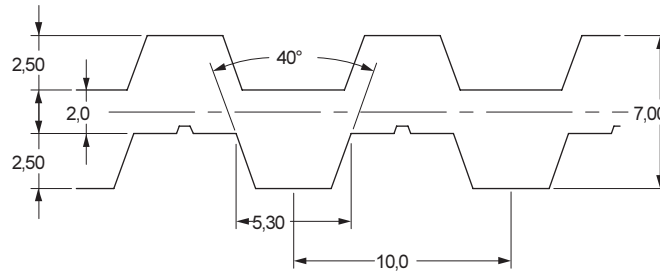

Belt marking	Number of teeth per side	Pitch length	Designation	Belt marking	Number of teeth per side	Pitch length	Designation
		mm				mm	
D...-T10-900	90	900	PHG D...-T10-900-...	D...-T10-1560	156	1560	PHG D...-T10-1560-...
D...-T10-910	91	910	PHG D...-T10-910-...	D...-T10-1600	160	1600	PHG D...-T10-1600-...
D...-T10-920	92	920	PHG D...-T10-920-...	D...-T10-1610	161	1610	PHG D...-T10-1610-...
D...-T10-950	95	950	PHG D...-T10-950-...	D...-T10-1640	164	1640	PHG D...-T10-1640-...
D...-T10-950	95	950	PHG D...-T10-950-...	D...-T10-1640	164	1640	PHG D...-T10-1640-...
D...-T10-960	96	960	PHG D...-T10-960-...	D...-T10-1690	169	1690	PHG D...-T10-1690-...
D...-T10-970	97	970	PHG D...-T10-970-...	D...-T10-1700	170	1700	PHG D...-T10-1700-...
D...-T10-980	98	980	PHG D...-T10-980-...	D...-T10-1750	175	1750	PHG D...-T10-1750-...
D...-T10-1000	100	1000	PHG D...-T10-1000-...	D...-T10-1780	178	1780	PHG D...-T10-1780-...
D...-T10-1010	101	1010	PHG D...-T10-1010-...	D...-T10-1800	180	1800	PHG D...-T10-1800-...
D...-T10-1040	104	1040	PHG D...-T10-1040-...	D...-T10-1860	186	1860	PHG D...-T10-1860-...
D...-T10-1050	105	1050	PHG D...-T10-1050-...	D...-T10-1880	188	1880	PHG D...-T10-1880-...
D...-T10-1080	108	1080	PHG D...-T10-1080-...	D...-T10-1960	196	1960	PHG D...-T10-1960-...
D...-T10-1100	110	1100	PHG D...-T10-1100-...	D...-T10-1980	198	1980	PHG D...-T10-1980-...
D...-T10-1110	111	1110	PHG D...-T10-1110-...	D...-T10-2020	202	2020	PHG D...-T10-2020-...
D...-T10-1140	114	1140	PHG D...-T10-1140-...	D...-T10-2080	208	2080	PHG D...-T10-2080-...
D...-T10-1150	115	1150	PHG D...-T10-1150-...	D...-T10-2090	209	2090	PHG D...-T10-2090-...
D...-T10-1200	120	1200	PHG D...-T10-1200-...	D...-T10-2100	210	2100	PHG D...-T10-2100-...
D...-T10-1210	121	1210	PHG D...-T10-1210-...	D...-T10-2200	220	2200	PHG D...-T10-2200-...
D...-T10-1240	124	1240	PHG D...-T10-1240-...	D...-T10-2250	225	2250	PHG D...-T10-2250-...
D...-T10-1250	125	1250	PHG D...-T10-1250-...	D...-T10-2270	227	2270	PHG D...-T10-2270-...
D...-T10-1260	126	1260	PHG D...-T10-1260-...	D...-T10-2300	230	2300	PHG D...-T10-2300-...
D...-T10-1280	128	1280	PHG D...-T10-1280-...	D...-T10-2340	234	2340	PHG D...-T10-2340-...
D...-T10-1300	130	1300	PHG D...-T10-1300-...	D...-T10-2360	236	2360	PHG D...-T10-2360-...
D...-T10-1320	132	1320	PHG D...-T10-1320-...	D...-T10-2380	238	2380	PHG D...-T10-2380-...
D...-T10-1350	135	1350	PHG D...-T10-1350-...	D...-T10-2430	243	2430	PHG D...-T10-2430-...
D...-T10-1390	139	1390	PHG D...-T10-1390-...	D...-T10-2480	248	2480	PHG D...-T10-2480-...
D...-T10-1400	140	1400	PHG D...-T10-1400-...	D...-T10-2500	250	2500	PHG D...-T10-2500-...
D...-T10-1420	142	1420	PHG D...-T10-1420-...	D...-T10-2540	254	2540	PHG D...-T10-2540-...
D...-T10-1440	144	1440	PHG D...-T10-1440-...	D...-T10-2590	259	2590	PHG D...-T10-2590-...
D...-T10-1450	145	1450	PHG D...-T10-1450-...	D...-T10-2610	261	2610	PHG D...-T10-2610-...
D...-T10-1460	146	1460	PHG D...-T10-1460-...	D...-T10-2650	265	2650	PHG D...-T10-2650-...
D...-T10-1480	148	1480	PHG D...-T10-1480-...	D...-T10-2800	280	2800	PHG D...-T10-2800-...
D...-T10-1500	150	1500	PHG D...-T10-1500-...	D...-T10-2880	288	2880	PHG D...-T10-2880-...
D...-T10-1520	152	1520	PHG D...-T10-1520-...	D...-T10-3000	300	3000	PHG D...-T10-3000-...

To complete designation add belt width in mm.

Non-standard lengths may also be available.

Double sided Metric belts are available in symmetric (DA) and asymmetric (DB) tooth profiles.

Symmetric will supplied unless otherwise specified

Full sleeves are available in various widths.

Please contact your SKF Authorized Distributor.

For polyurethane version, add "PU" to the profile type. For example: PHG T5PU-1000...

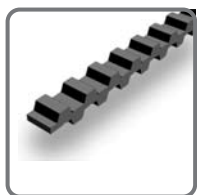

Double-sided metric timing belts

D-T20

Belt marking	Number of teeth per side	Pitch length	Designation
		mm	
D...-T20-1700	85	1700	PHG D...-T20-1700-...
D...-T20-1780	89	1780	PHG D...-T20-1780-...
D...-T20-1880	94	1880	PHG D...-T20-1880-...
D...-T20-2040	102	2040	PHG D...-T20-2040-...
D...-T20-2200	110	2200	PHG D...-T20-2200-...
D...-T20-2240	112	2240	PHG D...-T20-2240-...
D...-T20-2600	130	2600	PHG D...-T20-2600-...
D...-T20-2720	136	2720	PHG D...-T20-2720-...
D...-T20-2740	137	2740	PHG D...-T20-2740-...
D...-T20-2760	138	2760	PHG D...-T20-2760-...
D...-T20-3100	155	3100	PHG D...-T20-3100-...
D...-T20-3620	181	3620	PHG D...-T20-3620-...
D...-T20-4760	238	4760	PHG D...-T20-4760-...
D...-T20-5000	250	5000	PHG D...-T20-5000-...

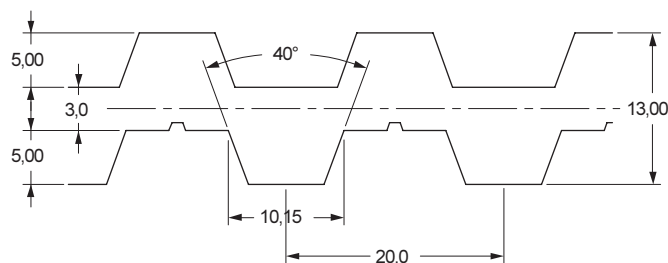

To complete designation add belt width in mm.

Non-standard lengths may also be available.

Double sided Metric belts are available in symmetric (DA) and asymmetric (DB) tooth profiles. Symmetric will supplied unless otherwise specified

Full sleeves are available in various widths. Please contact your SKF Authorized Distributor.

For polyurethane version, add "PU" to the profile type. For example: PHG T5PU-1000...

Chains





Roller chains

ANSI

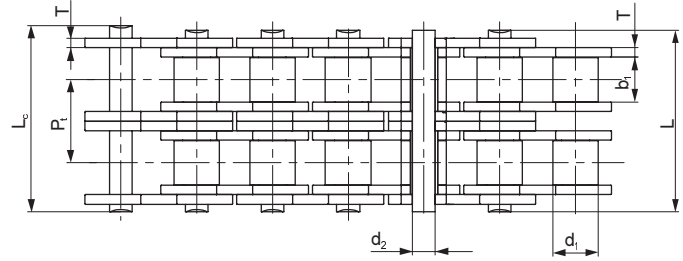
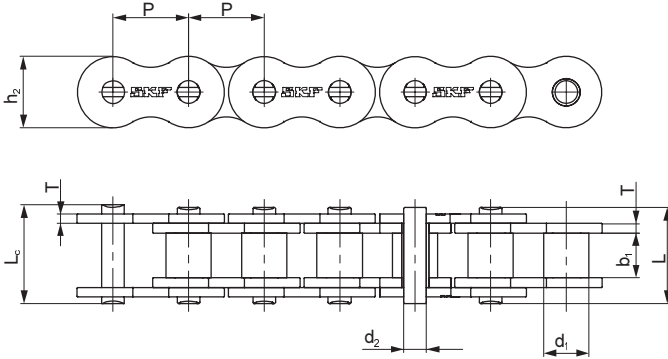

ANSI Chain No.	BS/ISO Chain No.	Pitch P	Roller diameter d ₂ max	Width between inner plates b ₁ max	Pin diameter d ₁ max	Pin length		Pin length cotted L _c max	Inner plate height h ₂ max	Plate thickness T max	Transverse pitch Pt	Ultimate tensile strength Q min	Average tensile strength Q ₀	Weight per meter q	Designation
						L max	L _c max								
15-1*	03C*	4,76	2,48	2,38	1,62	6,10	6,90	-	4,30	0,60	-	1,8	2,0	0,08	PHC 15-1...
25-1*	04C-1*	6,35	3,30	3,18	2,31	7,90	8,40	-	6,00	0,80	-	3,5	4,6	0,15	PHC 25-1...
35-1*	06C-1*	9,53	5,08	4,77	3,58	12,40	13,17	-	9,00	1,30	-	7,9	10,8	0,33	PHC 35-1...
41-1	085-1	12,70	7,77	6,25	3,58	13,75	15,00	-	9,91	1,30	-	6,7	12,6	0,41	PHC 41-1...
40-1	08A-1	12,70	7,95	7,85	3,96	16,60	17,80	-	12,00	1,50	-	14,1	17,5	0,62	PHC 40-1...
50-1	10A-1	15,88	10,16	9,40	5,08	20,70	22,20	23,3	15,09	2,03	-	22,2	29,4	1,02	PHC 50-1...
60-1	12A-1	19,05	11,91	12,57	5,94	25,90	27,70	28,3	18,00	2,42	-	31,8	41,5	1,50	PHC 60-1...
80-1	16A-1	25,40	15,88	15,75	7,92	32,70	35,00	36,5	24,00	3,25	-	56,7	69,4	2,60	PHC 80-1...
100-1	20A-1	31,75	19,05	18,90	9,53	40,40	44,70	44,7	30,00	4,00	-	88,5	109,2	3,91	PHC 100-1...
120-1	24A-1	38,10	22,23	25,22	11,10	50,30	54,30	54,3	35,70	4,80	-	127,0	156,3	5,62	PHC 120-1...
140-1	28A-1	44,45	25,40	25,22	12,70	54,40	59,00	59,0	41,00	5,60	-	172,4	212,0	7,50	PHC 140-1...
160-1	32A-1	50,80	28,58	31,55	14,27	64,80	69,60	69,6	47,80	6,40	-	226,8	278,9	10,10	PHC 160-1...
180-1	36A-1	57,15	35,71	35,48	17,46	72,80	78,60	78,6	53,60	7,20	-	280,2	341,8	13,45	PHC 180-1...
200-1	40A-1	63,50	39,68	37,85	19,85	80,30	87,20	87,2	60,00	8,00	-	353,8	431,6	16,15	PHC 200-1...
240-1	48A-1	76,20	47,63	47,35	23,81	95,50	103,00	103,0	72,39	9,50	-	510,3	622,5	23,20	PHC 240-1...
25-2*	04C-2*	6,35	3,30	3,18	2,31	14,50	15,00	-	6,00	0,80	6,40	7,0	8,6	0,28	PHC 25-2...
35-2*	06C-2*	9,53	5,08	4,77	3,58	22,50	23,30	-	9,00	1,30	10,13	15,8	19,7	0,63	PHC 35-2...
41-2	085-2	12,70	7,77	6,25	3,58	25,70	26,90	-	9,91	1,30	11,95	13,3	16,9	0,81	PHC 41-2...
40-2	08A-2	12,70	7,95	7,85	3,96	31,00	32,20	-	12,00	1,50	14,38	28,2	35,9	1,12	PHC 40-2...
50-2	10A-2	15,88	10,16	9,40	5,08	38,90	40,40	41,2	15,09	2,03	18,11	44,4	58,1	2,00	PHC 50-2...
60-2	12A-2	19,05	11,91	12,57	5,94	48,80	50,50	51,1	18,00	2,42	22,78	63,6	82,1	2,92	PHC 60-2...
80-2	16A-2	25,40	15,88	15,75	7,92	62,70	64,30	65,8	24,00	3,25	29,29	113,4	141,8	5,15	PHC 80-2...
100-2	20A-2	31,75	19,05	18,90	9,53	76,40	80,50	80,5	30,00	4,00	35,76	177,0	219,4	7,80	PHC 100-2...
120-2	24A-2	38,10	22,23	25,22	11,10	95,80	99,70	99,7	35,70	4,80	45,44	254,0	314,9	11,70	PHC 120-2...
140-2	28A-2	44,45	25,40	25,22	12,70	103,30	107,90	107,9	41,00	5,60	48,87	344,8	427,5	15,14	PHC 140-2...
160-2	32A-2	50,80	28,58	31,55	14,27	123,30	128,10	128,1	47,80	6,40	58,55	453,6	562,4	20,14	PHC 160-2...
180-2	36A-2	57,15	35,71	35,48	17,46	138,60	144,40	144,4	53,60	7,20	65,84	560,5	695,0	29,22	PHC 180-2...
200-2	40A-2	63,50	39,68	37,85	19,85	151,90	158,80	158,8	60,00	8,00	71,55	707,6	877,4	32,24	PHC 200-2...
240-2	48A-2	76,20	47,63	47,35	23,81	183,40	190,80	190,8	72,39	9,50	87,83	1020,6	1255,3	45,23	PHC 240-2...
25-3*	04C-3*	6,35	3,30	3,18	2,31	21,00	21,50	-	6,00	0,80	6,40	10,5	12,6	0,44	PHC 25-3...
35-3*	06C-3*	9,53	5,08	4,77	3,58	32,70	33,50	-	9,00	1,30	10,13	23,7	28,6	1,05	PHC 35-3...
40-3	08A-3	12,70	7,95	7,85	3,96	45,40	46,60	-	12,00	1,50	14,38	42,3	50,0	1,90	PHC 40-3...
50-3	10A-3	15,88	10,16	9,40	5,08	57,00	58,50	59,3	15,09	2,03	18,11	66,6	77,8	3,09	PHC 50-3...
60-3	12A-3	19,05	11,91	12,57	5,94	71,50	73,30	73,9	18,00	2,42	22,78	95,4	111,1	4,54	PHC 60-3...
80-3	16A-3	25,40	15,88	15,75	7,92	91,70	93,60	95,1	24,00	3,25	29,29	170,1	198,4	7,89	PHC 80-3...
100-3	20A-3	31,75	19,05	18,90	9,53	112,20	116,30	116,3	30,00	4,00	35,76	265,5	309,6	11,77	PHC 100-3...
120-3	24A-3	38,10	22,23	25,22	11,10	141,40	145,20	145,2	35,70	4,80	45,44	381,0	437,2	17,53	PHC 120-3...
140-3	28A-3	44,45	25,40	25,22	12,70	152,20	156,80	156,8	41,00	5,60	48,87	517,2	593,3	22,20	PHC 140-3...
160-3	32A-3	50,80	28,58	31,55	14,27	181,80	186,60	186,6	47,80	6,40	58,55	680,4	780,6	30,02	PHC 160-3...
180-3	36A-3	57,15	35,71	35,48	17,46	204,40	210,20	210,2	53,60	7,20	65,84	840,7	983,6	38,22	PHC 180-3...
200-3	40A-3	63,50	39,68	37,85	19,85	223,50	230,40	230,4	60,00	8,00	71,55	1061,4	1217,8	49,03	PHC 200-3...
240-3	48A-3	76,20	47,63	47,35	23,81	271,30	278,60	278,6	72,39	9,50	87,83	1530,9	1756,5	71,60	PHC 240-3...

* Bushing chain: d₁ indicates external diameter of bushing

For cotted add a "C" after the number of strands. For example 140-1 with a cotted pin is designated PHC 140-1C...

Standard lengths are 10 ft and 5 m. To complete designation add chain length. For example, a 10 ft box of 140-1 is PHC 140-1X10FT

For links add "C/L" for "connecting" and "O/L" for "offset" to the designation in the table



Roller chains

BS/ISO

- ▶ Belts
- ▶ Chains
- ▶ Couplings
- ▶ Bushings and Hubs
- ▶ Sprockets
- ▶ Pulleys
- ▶ Smart tools

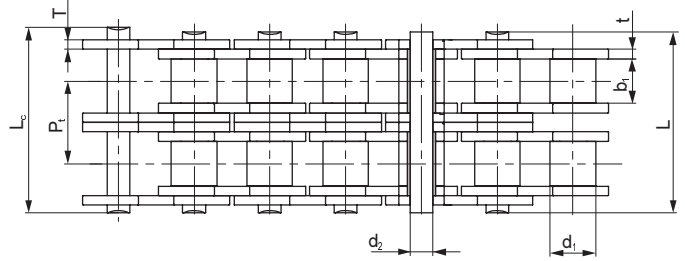
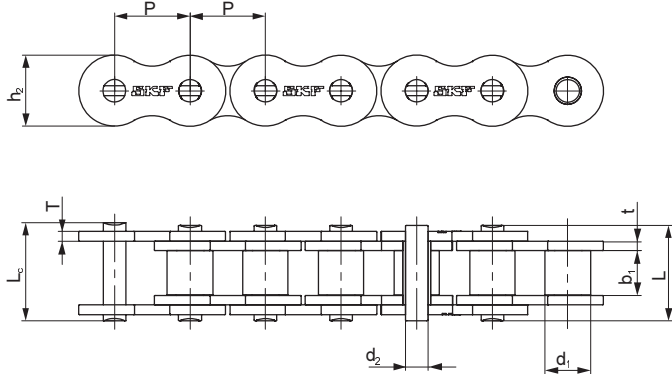

BS/ISO Chain No.	Pitch	Roller diameter	Width between inner plates	Pin diameter	Pin length		Inner plate height	Plate thickness		Transverse pitch	Ultimate tensile strength	Average tensile strength	Weight per meter	Designation
	P	d ₁ max	b ₁ max	d ₂ max	L max	L _i max	h ₂ max	t max	T max	Pt	Q min	Q _a	q	
	mm	mm	mm	mm	mm	mm	mm	mm	mm	mm	kN	kN	kg/m	
04B-1	6,00	4,00	2,80	1,85	6,80	7,8	5,00	0,60	0,60	-	3,0	3,2	0,11	PHC 04B-1...
05B-1	8,00	5,00	3,00	2,31	8,20	8,9	7,10	0,80	0,80	-	5,0	5,9	0,20	PHC 05B-1...
06B-1 [^]	9,53	6,35	5,72	3,28	13,15	14,1	8,20	1,30	1,30	-	9,0	10,4	0,41	PHC 06B-1...
08B-1	12,70	8,51	7,75	4,45	16,70	18,2	11,80	1,60	1,60	-	18,0	19,4	0,69	PHC 08B-1...
10B-1	15,88	10,16	9,65	5,08	19,50	20,9	14,70	1,70	1,70	-	22,4	27,5	0,93	PHC 10B-1...
12B-1	19,05	12,07	11,68	5,72	22,50	24,2	16,00	1,85	1,85	-	29,0	32,2	1,15	PHC 12B-1...
16B-1	25,40	15,88	17,02	8,28	36,10	37,4	21,00	4,15	3,10	-	60,0	72,8	2,71	PHC 16B-1...
20B-1	31,75	19,05	19,56	10,19	41,30	45,0	26,40	4,50	3,50	-	95,0	106,7	3,70	PHC 20B-1...
24B-1	38,10	25,40	25,40	14,63	53,40	57,8	33,20	6,00	4,80	-	160,0	178,0	7,10	PHC 24B-1...
28B-1	44,45	27,94	30,99	15,90	65,10	69,5	36,70	7,50	6,00	-	200,0	222,0	8,50	PHC 28B-1...
32B-1	50,80	29,21	30,99	17,81	66,00	71,0	42,00	7,00	6,00	-	250,0	277,5	10,25	PHC 32B-1...
40B-1	63,50	39,37	38,10	22,89	82,20	89,2	52,96	8,50	8,00	-	355,0	394,0	16,35	PHC 40B-1...
48B-1	76,20	48,26	45,72	29,24	99,10	107,0	63,80	12,00	10,00	-	560,0	621,6	25,00	PHC 48B-1...
56B-1	88,90	53,98	53,34	34,32	114,60	123,0	77,80	13,50	12,00	-	850,0	940,0	35,78	PHC 56B-1...
64B-1	101,60	63,50	60,96	39,40	130,00	138,5	90,17	15,00	13,00	-	1120,0	1240,0	46,00	PHC 64B-1...
72B-1	114,30	72,39	68,58	44,48	147,40	156,4	103,60	17,00	15,00	-	1400,0	1550,0	60,80	PHC 72B-1...
05B-2	8,00	5,00	3,00	2,31	13,90	14,5	7,10	0,80	0,80	5,64	7,8	10,2	0,33	PHC 05B-2...
06B-2 [^]	9,53	6,35	5,72	3,28	23,40	24,4	8,20	1,30	1,30	10,24	16,9	18,7	0,77	PHC 06B-2...
08B-2	12,70	8,51	7,75	4,45	31,20	32,2	11,80	1,60	1,60	13,92	32,0	38,7	1,34	PHC 08B-2...
10B-2	15,88	10,16	9,65	5,08	36,10	37,5	14,70	1,70	1,70	16,59	44,5	56,2	1,84	PHC 10B-2...
12B-2	19,05	12,07	11,68	5,72	42,00	43,6	16,00	1,85	1,85	19,46	57,8	66,1	2,31	PHC 12B-2...
16B-2	25,40	15,88	17,02	8,28	68,00	69,3	21,00	4,15	3,10	31,88	106,0	133,0	5,42	PHC 16B-2...
20B-2	31,75	19,05	19,56	10,19	77,80	81,5	26,40	4,50	3,50	36,45	170,0	211,2	7,20	PHC 20B-2...
24B-2	38,10	25,40	25,40	14,63	101,70	106,2	33,20	6,00	4,80	48,36	280,0	319,2	13,40	PHC 24B-2...
28B-2	44,45	27,94	30,99	15,90	124,60	129,1	36,70	7,50	6,00	59,56	360,0	406,8	16,60	PHC 28B-2...
32B-2	50,80	29,21	30,99	17,81	124,60	129,6	42,00	7,00	6,00	58,55	450,0	508,5	21,00	PHC 32B-2...
40B-2	63,50	39,37	38,10	22,89	154,50	161,5	52,96	8,50	8,00	72,29	630,0	711,9	32,00	PHC 40B-2...
48B-2	76,20	48,26	45,72	29,24	190,40	198,2	63,80	12,00	10,00	91,21	1000,0	1130,0	50,00	PHC 48B-2...
56B-2	88,90	53,98	53,34	34,32	221,20	229,6	77,80	13,50	12,00	106,60	1600,0	1760,0	71,48	PHC 56B-2...
64B-2	101,60	63,50	60,96	39,40	249,90	258,4	90,17	15,00	13,00	119,89	2000,0	2200,0	91,00	PHC 64B-2...
72B-2	114,30	72,39	68,58	44,48	283,70	292,7	103,60	17,00	15,00	136,27	2500,0	2750,0	120,40	PHC 72B-2...
05B-3	8,00	5,00	3,00	2,31	19,50	20,2	7,10	0,80	0,80	5,64	11,1	13,8	0,48	PHC 05B-3...
06B-3 [^]	9,53	6,35	5,72	3,28	33,50	34,6	8,20	1,30	1,30	10,24	24,9	30,1	1,16	PHC 06B-3...
08B-3	12,70	8,51	7,75	4,45	45,10	46,1	11,80	1,60	1,60	13,92	47,5	57,8	2,03	PHC 08B-3...
10B-3	15,88	10,16	9,65	5,08	52,70	54,1	14,70	1,70	1,70	16,59	66,7	84,5	2,77	PHC 10B-3...
12B-3	19,05	12,07	11,68	5,72	61,50	63,1	16,00	1,85	1,85	19,46	86,7	101,8	3,46	PHC 12B-3...
16B-3	25,40	15,88	17,02	8,28	99,80	101,2	21,00	4,15	3,10	31,88	160,0	203,7	8,13	PHC 16B-3...
20B-3	31,75	19,05	19,56	10,19	114,20	117,9	26,40	4,50	3,50	36,45	250,0	290,0	10,82	PHC 20B-3...
24B-3	38,10	25,40	25,40	14,63	150,10	154,6	33,20	6,00	4,80	48,36	425,0	493,0	20,10	PHC 24B-3...
28B-3	44,45	27,94	30,99	15,90	184,20	188,7	36,70	7,50	6,00	59,56	530,0	609,5	24,92	PHC 28B-3...
32B-3	50,80	29,21	30,99	17,81	183,20	188,2	42,00	7,00	6,00	58,55	670,0	770,5	31,56	PHC 32B-3...
40B-3	63,50	39,37	38,10	22,89	226,80	233,8	52,96	8,50	8,00	72,29	950,0	1092,5	48,10	PHC 40B-3...
48B-3	76,20	48,26	45,72	29,24	281,60	289,4	63,80	12,00	10,00	91,21	1500,0	1710,0	75,00	PHC 48B-3...
56B-3	88,90	53,98	53,34	34,32	327,80	336,2	77,80	13,50	12,00	106,60	2240,0	2240,0	107,18	PHC 56B-3...
64B-3	101,60	63,50	60,96	39,40	369,80	378,3	90,17	15,00	13,00	119,89	3000,0	3300,0	136,00	PHC 64B-3...
72B-3	114,30	72,39	68,58	44,48	420,00	429,0	103,60	17,00	15,00	136,27	3750,0	4125,0	180,00	PHC 72B-3...

[^] Straight side plates

Standard lengths are 10 ft and 5 m. To complete designation add chain length. For example, a 5 m box of 08B-1 is PHC 08B-1X5MTR

For links add "C/L" for "connecting" and "O/L" for "offset" to the designation in the table



Roller chains

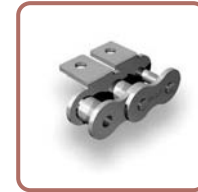

Attachments

A-1, K-1

A-1

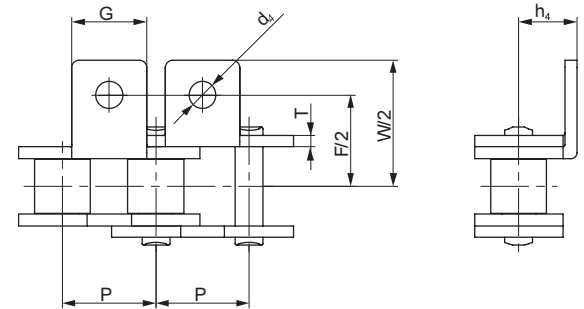

K-1

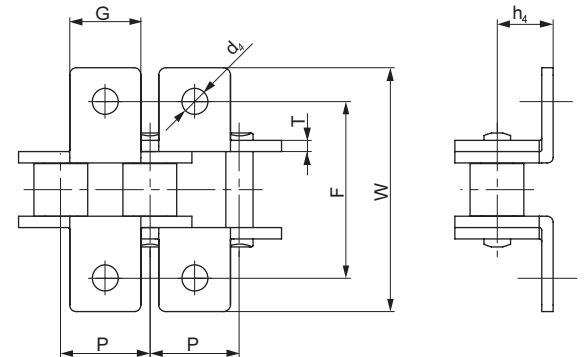

ANSI Chain No.	BS/ISO Chain No.	P mm	G mm	F mm	W mm	T mm	h ₄ mm	d _s mm	Designation
35-1	06C-1	9,53	7,9	19,00	28,6	1,30	6,35	3,4	PHC 35-1...
40-1	08A-1	12,70	9,5	25,40	35,2	1,50	7,90	3,4	PHC 40-1...
41-1	085-1	12,70	9,5	24,00	33,4	1,30	6,90	3,6	PHC 41-1...
50-1	10A-1	15,88	12,7	31,75	46,2	2,03	10,30	5,5	PHC 50-1...
60-1	12A-1	19,05	15,9	38,10	55,6	2,42	11,90	5,5	PHC 60-1...
80-1	16A-1	25,40	19,1	50,80	64,8	3,25	15,90	6,8	PHC 80-1...
100-1	20A-1	31,75	25,4	63,50	87,3	4,00	19,80	9,2	PHC 100-1...
120-1	24A-1	38,10	28,6	76,20	108,5	4,80	23,00	9,8	PHC 120-1...
140-1	28A-1	44,45	34,9	88,90	123,0	5,60	28,60	11,4	PHC 140-1...
160-1	32A-1	50,80	38,1	101,60	142,8	6,40	31,75	13,1	PHC 160-1...
200-1	40A-1	63,50	50,8	127,00	179,0	8,00	42,88	16,3	PHC 200-1...
-	06B-1 [^]	9,53	8,0	19,04	27,0	1,30	6,50	3,5	PHC 06B-1...
-	08B-1	12,70	9,5	25,40	36,4	1,60	8,90	4,5	PHC 08B-1...
-	10B-1	15,88	14,3	31,75	44,6	1,70	10,31	5,3	PHC 10B-1...
-	12B-1	19,05	16,0	38,10	52,4	1,85	13,46	6,4	PHC 12B-1...
-	16B-1	25,40	19,1	50,80	72,6	3,10	15,88	6,4	PHC 16B-1...
-	20B-1	31,75	35,0	63,50	100,5	3,50	19,80	9,0	PHC 20B-1...
-	24B-1	38,10	30,0	76,20	108,4	4,80	26,67	10,5	PHC 24B-1...
-	28B-1	44,45	35,0	88,90	123,0	6,00	28,58	13,1	PHC 28B-1...
-	32B-1	50,80	38,1	101,60	142,8	6,00	31,75	13,1	PHC 32B-1...

[^] Straight side plates

To complete designation add attachment spacing and type followed by chain length.

For example : PHC 40-1-L2A1X10FT (ANSI 40-1 with A-1 attachment on every second link, 10 ft length)

Note: Also available in stainless steel.

When ordering suffix with SS, for example: PHC 40-1SS-L1A1X10FT

Roller chains



Attachments

SA-1/M1, SK-1/M1

SA-1/M1

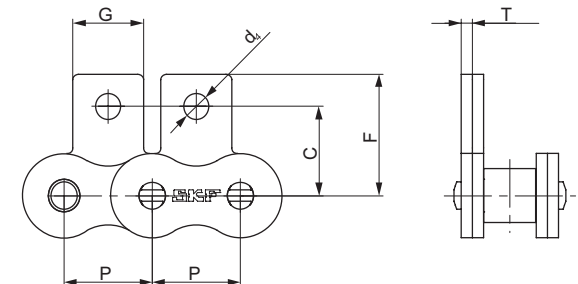

SK-1/M1

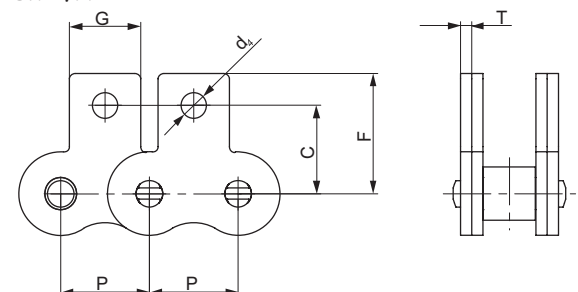

ANSI Chain No.	BS/ISO Chain No.	P mm	G mm	C mm	F mm	T mm	d _s mm	Designation
35-1	06C-1	9,53	7,9	9,50	14,55	1,30	3,4	PHC 35-1...
40-1	08A-1	12,70	9,5	12,70	19,05	1,50	3,4	PHC 40-1...
41-1	085-1	12,70	9,5	11,85	16,55	1,30	3,6	PHC 41-1...
50-1	10A-1	15,88	12,7	15,90	25,25	2,03	5,5	PHC 50-1...
60-1	12A-1	19,05	15,9	18,30	29,33	2,42	5,5	PHC 60-1...
80-1	16A-1	25,40	19,1	24,60	34,70	3,25	6,8	PHC 80-1...
100-1	20A-1	31,75	25,4	31,80	43,30	4,00	9,2	PHC 100-1...
120-1	24A-1	38,10	28,6	36,50	51,60	4,80	9,8	PHC 120-1...
140-1	28A-1	44,45	34,9	44,50	62,00	5,60	11,4	PHC 140-1...
160-1	32A-1	50,80	38,1	50,80	69,85	6,40	13,1	PHC 160-1...
200-1	40A-1	63,50	50,8	63,50	88,90	8,00	16,3	PHC 200-1...
-	06B-1 [^]	9,53	8,0	9,52	13,50	1,30	3,5	PHC 06B-1...
-	08B-1	12,70	9,5	13,35	18,90	1,60	4,3	PHC 08B-1...
-	10B-1	15,88	14,3	16,50	22,95	1,70	5,3	PHC 10B-1...
-	12B-1	19,05	16,0	21,45	28,60	1,85	6,4	PHC 12B-1...
-	16B-1	25,40	19,1	23,15	34,00	3,10	6,4	PHC 16B-1...
-	20B-1	31,75	35,0	30,50	45,70	3,50	9,0	PHC 20B-1...

[^] Straight side plates

To complete designation add attachment spacing and type followed by chain length.

For example: PHC 80-1-L1SK1X10FT (ANSI 80-1 with SK-1 attachment on every link, 10 ft length)

Note: Also available in stainless steel. When ordering suffix with SS, for example:

PHC 80-1SS-L1SK1X10FT

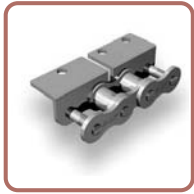

Roller chains

Attachments

WA-1, WA-2, WK-1, WK-2

- ▶ Belts
- ▶ Chains
- ▶ Couplings
- ▶ Bushings and Hubs
- ▶ Sprockets
- ▶ Pulleys
- ▶ Smart tools

ANSI Chain No.	BS/ISO Chain No.	P	G	L	F	W	T	h _t	d _t	Designation
		mm	mm	mm	mm	mm	mm	mm	mm	
35-1	06C-1	9,53	17,32	9,53	19,00	28,6	1,30	6,35	2,80	PHC 35-1...
40-1	08A-1	12,70	23,00	12,70	25,40	35,6	1,50	7,90	3,40	PHC 40-1...
41-1	085-1	12,70	22,30	12,70	24,00	35,0	1,30	7,20	4,85	PHC 41-1...
50-1	10A-1	15,88	28,80	15,88	31,75	46,8	2,03	10,30	5,50	PHC 50-1...
60-1	12A-1	19,05	34,65	19,05	38,10	56,4	2,42	11,90	5,50	PHC 60-1...
80-1	16A-1	25,40	45,90	25,40	50,80	73,2	3,25	15,90	6,80	PHC 80-1...
100-1	20A-1	31,75	57,65	31,75	63,50	89,8	4,00	19,80	9,20	PHC 100-1...
120-1	24A-1	38,10	69,30	38,10	76,20	108,8	4,80	23,00	9,80	PHC 120-1...
140-1	28A-1	44,45	80,45	44,45	88,90	123,0	5,60	28,60	11,40	PHC 140-1...
160-1	32A-1	50,80	92,00	50,80	101,60	142,8	6,40	31,75	13,10	PHC 160-1...
200-1	40A-1	63,50	115,50	63,50	127,00	179,0	8,00	42,88	16,30	PHC 200-1...
-	08B-1	12,70	24,00	12,70	25,40	36,4	1,60	8,90	4,30	PHC 08B-1...
-	10B-1	15,88	29,58	15,88	31,80	44,6	1,70	10,31	5,30	PHC 10B-1...
-	12B-1	19,05	34,05	19,05	38,10	52,0	1,85	13,46	6,40	PHC 12B-1...
-	16B-1	25,40	46,40	25,40	50,80	72,6	3,10	15,88	6,40	PHC 16B-1...
-	20B-1	31,75	58,10	31,75	63,00	100,5	3,50	19,80	9,00	PHC 20B-1...
-	24B-1	38,10	71,30	38,10	76,20	108,4	4,80	26,67	10,50	PHC 24B-1...
-	28B-1	44,45	81,10	44,45	88,90	123,0	6,00	28,58	13,10	PHC 28B-1...
-	32B-1	50,80	92,80	50,80	101,60	142,8	6,00	31,75	13,10	PHC 32B-1...

WA-1,WA-2

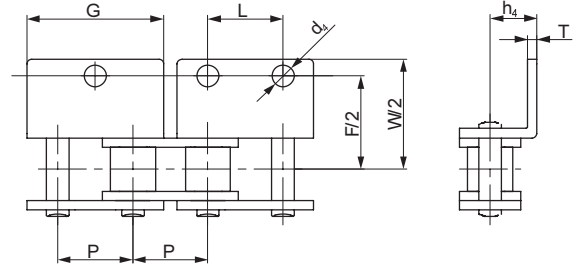

WK-1,WK-2

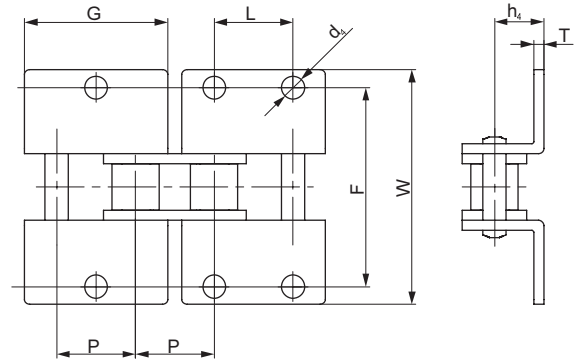

To complete designation add attachment spacing and type followed by chain length.
For example: PHC 80-1-L2WA2X10FT (ANSI 80-1 with WA-2 attachment on every second link, 10 ft length)

Note: Also available in stainless steel. When ordering suffix with SS, for example: PHC 80-1SS-L2WA2X10FT

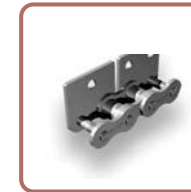

Roller chains

Attachments

WSA-1, WSA-2, WSK-1, WSK-2

ANSI Chain No.	BS/ISO Chain No.	P	G	L	C	F	T	d _t	Designation
		mm	mm	mm	mm	mm	mm	mm	
35-1	06C-1	9,53	17,32	9,53	9,50	14,55	1,30	2,8	PHC 35-1...
40-1	08A-1	12,70	23,00	12,70	17,40	17,40	1,50	3,4	PHC 40-1...
41-1	085-1	12,70	21,20	12,70	11,85	16,55	1,30	3,6	PHC 41-1...
50-1	10A-1	15,88	28,80	15,88	15,90	23,05	2,03	5,5	PHC 50-1...
60-1	12A-1	19,05	34,65	19,05	18,30	26,86	2,42	5,5	PHC 60-1...
80-1	16A-1	25,40	45,90	25,40	24,60	35,45	3,25	6,8	PHC 80-1...
100-1	20A-1	31,75	57,65	31,75	31,80	44,00	4,00	9,2	PHC 100-1...
120-1	24A-1	38,10	69,30	38,10	36,50	51,60	4,80	9,8	PHC 120-1...
140-1	28A-1	44,45	80,45	44,45	44,50	62,00	5,60	11,4	PHC 140-1...
160-1	32A-1	50,80	92,00	50,80	50,80	69,85	6,40	13,1	PHC 160-1...
200-1	40A-1	63,50	115,50	63,50	63,50	88,90	8,00	16,3	PHC 200-1...
-	08B-1	12,70	23,30	12,70	13,35	18,90	1,60	4,3	PHC 08B-1...
-	10B-1	15,88	29,58	15,88	16,50	22,95	1,70	5,3	PHC 10B-1...
-	12B-1	19,05	34,05	19,05	21,45	28,60	1,85	6,4	PHC 12B-1...
-	16B-1	25,40	46,40	25,40	23,15	34,00	3,10	6,4	PHC 16B-1...
-	20B-1	31,75	58,10	31,75	30,50	45,70	3,50	9,0	PHC 20B-1...

WSA-1,WSA-2

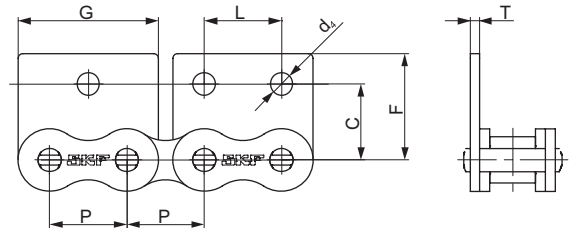

WSK-1,WSK-2

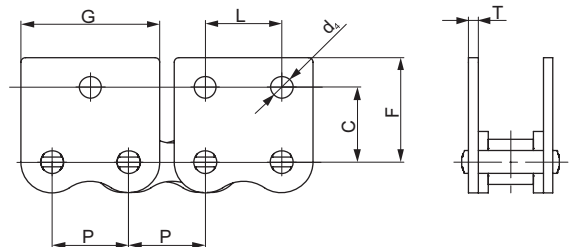

To complete designation add attachment spacing and type followed by chain length.
For example: PHC 80-1-L4WSA1X10FT (ANSI 80-1 with WSA-1 attachment on every fourth link, 10 ft length)

Note: Also available in stainless steel. When ordering suffix with SS, for example: PHC 80-1SS L4WSA1X10FT



Roller chains

ANSI heavy duty

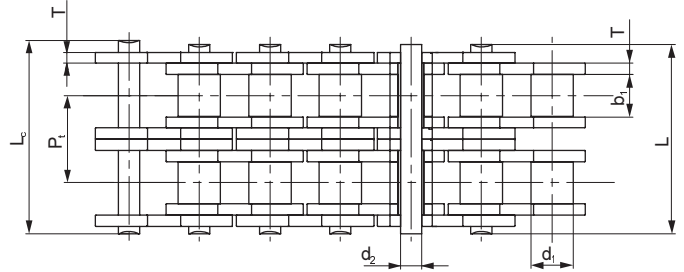
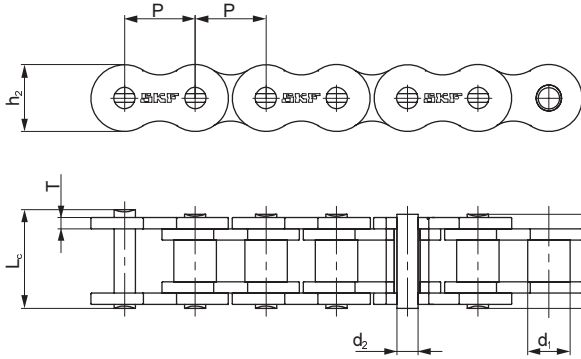

ANSI Chain No.	BS/ISO Chain No.	Pitch	Roller diameter	Width between inner plates		Pin diameter		Pin length		Pin length cottored	Inner plate height	Plate thickness	Transverse pitch	Ultimate tensile strength	Average tensile strength	Weight per meter	Designation
		P	d ₁ max	b ₁ max	d ₂ max	L max	L _c max	L _c max	h ₂ max					T max	Pt		
		mm	mm	mm	mm	mm	mm	mm	mm	mm	mm	mm	mm	kN	kN	kg/m	
35H-1*	-	9,53	5,08	4,77	3,58	13,3	14,3	-	9,00	1,50	-	7,9	10,8	0,41	PHC 35H-1...		
40H-1	08AH-1	12,70	7,95	7,85	3,96	18,8	19,9	-	12,00	2,03	-	14,1	19,1	0,82	PHC 40H-1...		
50H-1	10AH-1	15,88	10,16	9,40	5,08	22,1	23,4	24,4	15,09	2,42	-	22,2	30,2	1,25	PHC 50H-1...		
60H-1	12AH-1	19,05	11,91	12,57	5,94	29,2	31,0	31,6	18,00	3,25	-	31,8	42,7	1,87	PHC 60H-1...		
80H-1	16AH-1	25,40	15,88	15,75	7,92	36,2	37,7	39,4	24,00	4,00	-	56,7	71,4	3,10	PHC 80H-1...		
100H-1	20AH-1	31,75	19,05	18,90	9,53	43,6	46,9	46,9	30,00	4,80	-	88,5	112,4	4,52	PHC 100H-1...		
120H-1	24AH-1	38,10	22,23	25,22	11,10	53,5	57,5	57,5	35,70	5,60	-	127,0	160,9	6,60	PHC 120H-1...		
140H-1	28AH-1	44,45	25,40	25,22	12,70	57,6	62,2	62,2	41,00	6,40	-	172,4	217,3	8,30	PHC 140H-1...		
160H-1	32AH-1	50,80	28,58	31,55	14,27	68,2	73,0	73,0	47,80	7,20	-	226,8	285,8	10,30	PHC 160H-1...		
180H-1	36AH-1	57,15	35,71	35,48	17,46	75,9	81,6	-	53,60	8,00	-	281,0	341,8	14,83	PHC 180H-1...		
200H-1	40AH-1	63,50	39,68	37,85	19,85	86,6	93,5	93,5	60,00	9,50	-	353,8	444,5	19,16	PHC 200H-1...		
240H-1	48AH-1	76,20	47,63	47,35	23,81	109,6	115,9	-	72,30	12,70	-	510,3	622,5	30,40	PHC 240H-1...		
60H-2	12AH-2	19,05	11,91	12,57	5,94	55,3	57,1	57,7	18,00	3,25	26,11	63,6	84,5	3,71	PHC 60H-2...		
80H-2	16AH-2	25,40	15,88	15,75	7,92	68,8	70,3	72,0	24,00	4,00	32,59	113,4	145,3	6,15	PHC 80H-2...		
100H-2	20AH-2	31,75	19,05	18,90	9,53	82,7	86,0	86,0	30,00	4,80	39,09	177,0	225,9	9,03	PHC 100H-2...		
120H-2	24AH-2	38,10	22,23	25,22	11,10	102,4	106,4	106,4	35,70	5,60	48,87	254,0	322,7	13,13	PHC 120H-2...		
140H-2	28AH-2	44,45	25,40	25,22	12,70	109,8	114,4	114,4	41,00	6,40	52,20	344,8	437,7	16,60	PHC 140H-2...		
160H-2	32AH-2	50,80	28,58	31,55	14,27	130,1	134,9	134,9	47,80	7,20	61,90	453,6	571,6	20,20	PHC 160H-2...		
200H-2	40AH-2	63,50	39,68	37,85	19,85	164,9	171,8	171,8	60,00	9,50	78,31	707,6	894,9	38,11	PHC 200H-2...		
60H-3	12AH-3	19,05	11,91	12,57	5,94	81,4	83,2	83,8	18,00	3,25	26,11	95,4	113,9	5,54	PHC 60H-3...		
80H-3	16AH-3	25,40	15,88	15,75	7,92	101,4	102,9	104,6	24,00	4,00	32,59	170,1	203,5	9,42	PHC 80H-3...		
100H-3	20AH-3	31,75	19,05	18,90	9,53	121,8	125,1	125,1	30,00	4,80	39,09	265,5	314,8	12,96	PHC 100H-3...		
120H-3	24AH-3	38,10	22,23	25,22	11,10	151,2	155,2	155,2	35,70	5,60	48,87	381,0	444,7	19,64	PHC 120H-3...		
140H-3	28AH-3	44,45	25,40	25,22	12,70	162,0	166,6	166,6	41,00	6,40	52,20	517,2	598,4	24,90	PHC 140H-3...		
160H-3	32AH-3	50,80	28,58	31,55	14,27	192,0	196,8	196,8	47,80	7,20	61,90	680,4	787,3	30,10	PHC 160H-3...		
200H-3	40AH-3	63,50	39,68	37,85	19,85	243,2	250,1	250,1	60,00	9,50	78,31	1061,4	1228,2	57,06	PHC 200H-3...		

* Bushing chain: d₁ indicates external diameter of bushing

For cottored add a "C" after the number of strands. For example 160H-1 with a cottored pin is designated PHC 160H-1C...

Standard lengths are 10 ft and 5 m. To complete designation add chain length. For example, a 5 m box of 160H-1 is PHC 160H-1X5MTR

For links add "C/L" for "connecting" and "O/L" for "offset" to the designation in the table



Roller chains

SH Super Heavy

- ▶ Belts
- ▶ Chains
- ▶ Couplings
- ▶ Bushings and Hubs
- ▶ Sprockets
- ▶ Pulleys
- ▶ Smart tools

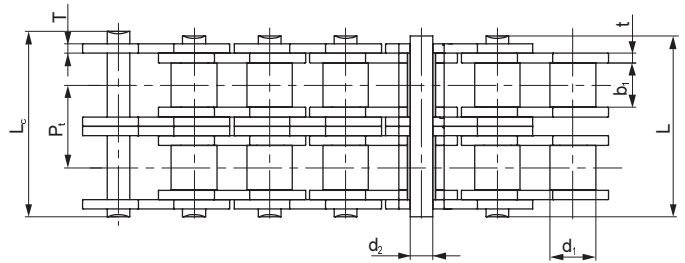
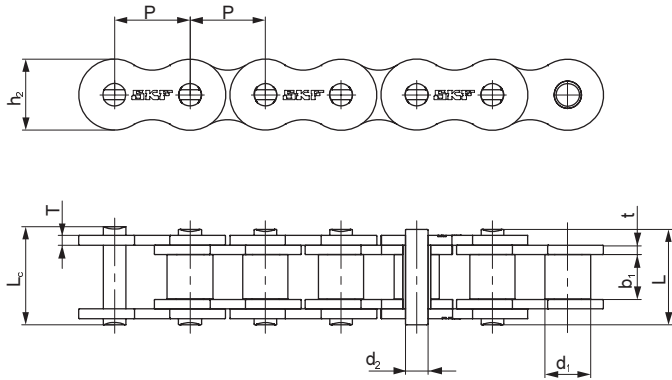

High strength Super Heavy (SH) series roller chains have a 25-35 % greater ultimate tensile strength over ANSI heavy duty roller chains due to their through hardened pins. These chains provide greater shock load resistance and improved service life whilst retaining the same dimensions as ANSI heavy duty series roller chains.

Chain No.	Pitch	Roller diameter	Width between inner plates	Pin diameter	Pin length		Inner plate height	Plate thickness	Ultimate tensile strength	Average tensile strength	Weight per meter	Designation
	P	d ₁ max	b ₁ max	d ₂ max	L max	L _c max	h ₂ max	T max	Q min	Q ₀	q	
	mm	mm	mm	mm	mm	mm	mm	mm	kN	kN	kg/m	
25SH-1*	6,35	3,30	3,18	2,01	9,0	-	6,00	2,01	5,09	5,6	2,17	PHC 25SH-1X...
35SH-1*	9,53	5,08	4,77	3,58	13,3	14,3	9,00	1,50	11,00	13,6	0,41	PHC 35SH-1X...
40SH-1	12,70	7,95	7,85	3,96	18,8	19,9	12,00	2,03	22,40	24,8	0,82	PHC 40SH-1X...
50SH-1	15,88	10,16	9,40	5,08	22,1	23,4	15,09	2,42	30,40	36,2	1,25	PHC 50SH-1X...
60SH-1	19,05	11,91	12,57	5,94	29,2	31,6	18,00	3,25	44,10	50,4	1,87	PHC 60SH-1X...
80SH-1	25,40	15,88	15,75	7,92	36,2	37,7	24,00	4,00	88,20	93,0	3,10	PHC 80SH-1X...
100SH-1	31,75	19,05	18,90	9,53	43,6	46,9	30,00	4,80	116,60	129,1	4,52	PHC 100SH-1X...
120SH-1	38,10	22,23	25,22	11,10	53,5	57,5	35,70	5,60	158,20	175,3	6,60	PHC 120SH-1X...
140SH-1	44,45	25,40	25,22	12,70	57,6	62,2	41,00	6,40	206,00	266,5	8,30	PHC 140SH-1X...
160SH-1	50,80	28,58	31,55	14,27	68,2	73,0	47,80	7,20	274,00	293,0	10,30	PHC 160SH-1X...
200SH-1	63,50	39,68	37,85	19,85	86,6	93,5	60,00	9,50	506,10	562,3	19,16	PHC 200SH-1X...

* Bushing chain: d₁ indicates external diameter of bushing

Standard lengths are 10 ft and 5 m. To complete designation add chain length. For example, a 5 m box of 100SH-1 is PHC 100SH-1X5MTR
For "connecting" links add "C/L" to the designation in the table.



Roller chains

SPH Super Heavy

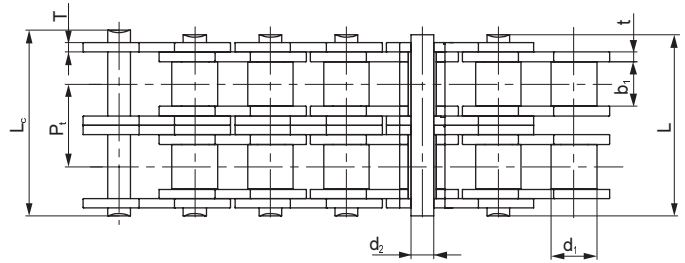
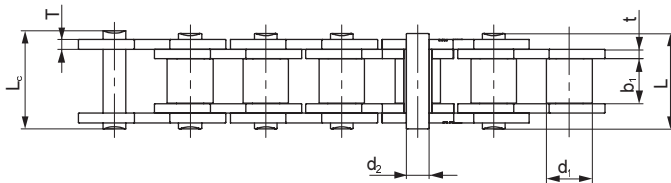
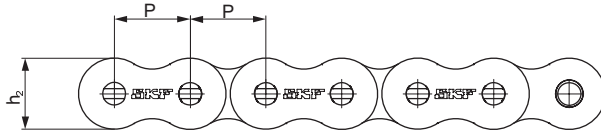

The link plates and pins of this series chains come with a special design and the pins are through hardened for greater shock load resistance. The ultimate tensile strength is up to 18% higher than normal chains. The dimensions of these chains are the same as ANSI standard chains.

Chain No.	Pitch	Roller diameter	Width between inner plates	Pin diameter	Pin length		Inner plate height	Plate thickness	Transverse pitch	Ultimate tensile strength	Average tensile strength	Weight per meter	Designation
	P	d ₁ max	b ₁ max	d ₂ max	L max	L _r max	h ₂ max	T max	Pt	Q min	Q ₀	q	
	mm	mm	mm	mm	mm	mm	mm	mm	mm	kN	kN	kg/m	
80SPH-1	25,40	15,88	15,75	7,94	32,7	36,5	24,1	3,2	-	77,5	85,3	2,86	PHC80SPH-1X...
100SPH-1	31,75	19,05	18,95	9,54	40,4	44,7	30,1	4,0	-	115,5	127,0	4,21	PHC100SPH-1X...
120SPH-1	38,10	22,23	25,22	11,11	50,3	54,3	36,2	4,8	-	165,0	186,0	6,36	PHC120SPH-1X...
140SPH-1	44,45	25,40	25,22	12,71	54,4	59,0	42,2	5,6	-	222,7	245,0	8,04	PHC140SPH-1X...
160SPH-1	50,80	28,58	31,55	14,29	64,8	69,6	48,2	6,4	-	285,5	314,0	10,80	PHC160SPH-1X...
200SPH-1	63,50	39,68	37,85	19,85	80,3	87,2	60,3	8,0	-	445,5	490,0	18,00	PHC200SPH-1X...
80SPH-2	25,40	15,88	15,75	7,94	62,7	65,8	24,1	3,2	29,29	155,0	170,6	5,68	PHC80SPH-2X...
100SPH-2	31,75	19,05	18,95	9,54	76,4	80,5	30,1	4,0	35,76	231,0	255,0	8,34	PHC100SPH-2X...
120SPH-2	38,10	22,23	25,22	11,11	95,8	99,7	36,2	4,8	45,44	339,0	373,0	12,63	PHC120SPH-2X...
140SPH-2	44,45	25,40	25,22	12,71	103,3	107,9	42,2	5,6	48,87	445,5	490,0	15,92	PHC140SPH-2X...
160SPH-2	50,80	28,58	31,55	14,29	123,3	128,1	48,2	6,4	58,55	571,0	628,0	21,43	PHC160SPH-2X...
200SPH-2	63,50	39,68	37,85	19,85	151,9	158,8	60,3	8,0	71,55	892,0	981,0	35,00	PHC200SPH-2X...
80SPH-3	25,40	15,88	15,75	7,94	91,7	95,1	24,1	3,2	29,29	232,5	255,9	8,18	PHC80SPH-3X...
100SPH-3	31,75	19,05	18,95	9,54	112,2	116,3	30,1	4,0	35,76	347,3	382,0	12,47	PHC100SPH-3X...
120SPH-3	38,10	22,23	25,22	11,11	141,4	145,2	36,2	4,8	45,44	508,0	559,0	18,90	PHC120SPH-3X...
140SPH-3	44,45	25,40	25,22	12,71	152,2	156,8	42,2	5,6	48,87	668,0	735,0	23,84	PHC140SPH-3X...
160SPH-3	50,80	28,58	31,55	14,29	181,8	186,6	48,2	6,4	58,55	855,5	941,0	32,10	PHC160SPH-3X...
200SPH-3	63,50	39,68	37,85	19,85	223,5	230,4	60,3	8,0	71,55	1336,4	1470,0	52,50	PHC200SPH-3X...

Standard lengths are 10 ft and 5 m. To complete designation add chain length. For example, a 5 m box of 100SH-1 is PHC 100SH-1X5MTR
For "connecting" links add "C/L" to the designation in the table.



Roller chains

SHH Super Heavy

- ▶ Belts
- ▶ Chains
- ▶ Couplings
- ▶ Bushings and Hubs
- ▶ Sprockets
- ▶ Pulleys
- ▶ Smart tools

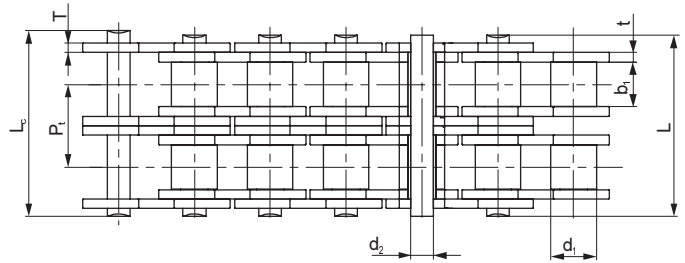
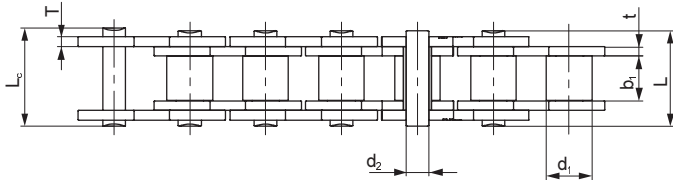
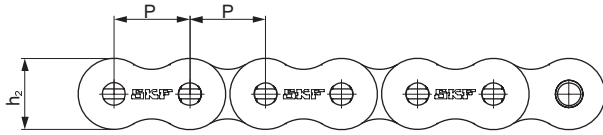

The thickness of SHH series link plates is the same as the next larger size of SPH chains. The pins are also through hardened. As a consequence greater allowable tension and ultimate tensile strength is achieved compared to SPH and SH chains. The ultimate tensile strength is up to 11% higher than the SPH chains.

Chain No.	Pitch	Roller diameter	Width between inner plates		Pin diameter		Pin length		Inner plate height	Plate thickness	Transverse pitch	Ultimate tensile strength	Average tensile strength	Weight per meter	Designation
	P	d ₁ max	b ₁ max	d ₂ max	L max	L ₁ max	h ₂ max	T max							
	mm	mm	mm	mm	mm	mm	mm	mm	mm	mm	mm	kN	kN	kg/m	
80SHH-1	25,40	15,88	15,75	7,94	36,2	38,9	24,1	4,0	-	-	89,2	98,1	3,36	PHC 80SHH-1X...	
100SHH-1	31,75	19,05	18,90	9,54	43,6	46,9	30,1	4,8	-	-	131,8	145,0	4,90	PHC 100SHH-1X...	
120SHH-1	38,10	22,23	25,22	11,11	53,5	57,5	36,2	5,6	-	-	176,0	196,0	7,12	PHC 120SHH-1X...	
140SHH-1	44,45	25,40	25,22	12,71	57,6	62,2	42,2	6,4	-	-	231,9	255,0	8,88	PHC 140SHH-1X...	
160SHH-1	50,80	28,58	31,55	14,29	68,2	73,0	48,2	7,2	-	-	294,5	324,0	11,72	PHC 160SHH-1X...	
200SHH-1	63,50	39,68	37,85	19,85	86,6	93,5	60,3	9,5	-	-	543,6	598,0	19,80	PHC 200SHH-1X...	
80SHH-2	25,40	15,88	15,75	7,94	68,8	72,0	24,1	4,0	32,59	-	178,4	196,2	6,65	PHC 80SHH-2X...	
100SHH-2	31,75	19,05	18,90	9,54	82,7	86,0	30,1	4,8	39,09	-	263,6	290,0	9,71	PHC 100SHH-2X...	
120SHH-2	38,10	22,23	25,22	11,11	102,4	106,4	36,2	5,6	48,87	-	356,4	392,0	14,12	PHC 120SHH-2X...	
140SHH-2	44,45	25,40	25,22	12,71	109,8	114,4	42,2	6,4	52,20	-	463,6	510,0	17,38	PHC 140SHH-2X...	
160SHH-2	50,80	28,58	31,55	14,29	130,1	134,9	48,2	7,2	61,90	-	588,0	647,0	23,00	PHC 160SHH-2X...	
200SHH-2	63,50	39,68	37,85	19,85	164,9	171,8	60,3	9,5	78,31	-	1091,0	1200,0	38,50	PHC 200SHH-2X...	
80SHH-3	25,40	15,88	15,75	7,94	101,4	104,6	24,1	4,0	32,59	-	267,6	294,3	9,95	PHC 80SHH-3X...	
100SHH-3	31,75	19,05	18,90	9,54	121,8	125,1	30,1	4,8	39,09	-	395,4	435,0	14,53	PHC 100SHH-3X...	
120SHH-3	38,10	22,23	25,22	11,11	151,2	155,2	36,2	5,6	48,87	-	534,5	588,0	21,12	PHC 120SHH-3X...	
140SHH-3	44,45	25,40	25,22	12,71	162,0	166,6	42,2	6,4	52,20	-	695,5	765,0	25,88	PHC 140SHH-3X...	
160SHH-3	50,80	28,58	31,55	14,29	192,0	196,8	48,2	7,2	61,90	-	882,7	971,0	34,22	PHC 160SHH-3X...	
200SHH-3	63,50	39,68	37,85	19,85	243,2	250,1	60,3	9,5	78,31	-	1627,3	1790,0	57,29	PHC 200SHH-3X...	

Standard lengths are 10 ft and 5 m. To complete designation add chain length. For example, a 5 m box of 100SHH-1 is PHC 100SHH-1X5MTR
For "connecting" links add "C/L" to the designation in the table.



Roller chains

Stainless steel

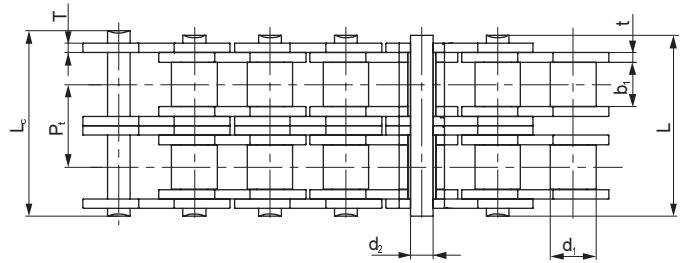
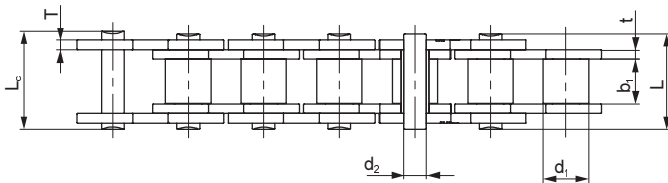
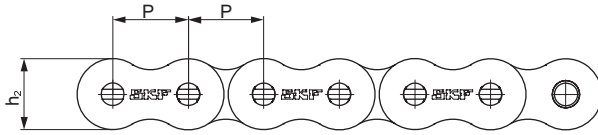

Chain No.	Pitch	Roller diameter	Width between inner plates	Pin diameter	Pin length		Inner plate height	Plate thickness		Ultimate tensile strength	Weight per meter	Designation
	P	d ₁ max	b ₁ max	d ₂ max	L max	L max	h ₂ max	t max	T max	Q min	q	
	mm	mm	mm	mm	mm	mm	mm	mm	mm	kN	kg/m	
25-1SS*	6,35	3,30	3,18	2,31	7,90	8,40	6,00	0,80	0,80	2,5	0,15	PHC 25-1SS...
35-1SS*	9,53	5,08	4,77	3,58	12,40	13,17	9,00	1,30	1,30	5,5	0,33	PHC 35-1SS...
40-1SS	12,70	7,95	7,85	3,96	16,60	17,80	12,00	1,50	1,50	9,6	0,63	PHC 40-1SS...
41-1SS	12,70	7,77	6,25	3,58	13,75	15,00	9,91	1,30	1,30	6,0	0,46	PHC 41-1SS...
50-1SS	15,88	10,16	9,40	5,08	20,70	22,20	15,09	2,03	2,03	15,2	1,03	PHC 50-1SS...
60-1SS	19,05	11,91	12,57	5,94	25,90	27,70	18,00	2,42	2,42	21,7	1,51	PHC 60-1SS...
80-1SS	25,40	15,88	15,75	7,92	32,70	35,00	24,00	3,25	3,25	38,9	2,62	PHC 80-1SS...
100-1SS	31,75	19,05	18,90	9,53	40,40	44,70	30,00	4,00	4,00	60,0	3,94	PHC 100-1SS...
120-1SS	38,10	22,23	25,22	11,10	50,30	54,30	35,70	4,80	4,80	72,5	5,72	PHC 120-1SS...
140-1SS	44,45	25,40	25,22	12,70	54,40	59,00	41,00	5,60	5,60	94,0	7,70	PHC 140-1SS...
04B-1SS	6,00	4,00	2,80	1,85	6,80	7,80	5,00	0,60	0,60	2,0	0,11	PHC 04B-1SS...
05B-1SS	8,00	5,00	3,00	2,31	8,20	8,90	7,10	0,80	0,80	3,5	0,20	PHC 05B-1SS...
06B-1SS^	9,53	6,35	5,72	3,28	13,15	14,10	8,20	1,30	1,30	6,2	0,41	PHC 06B-1SS...
08B-1SS	12,70	8,51	7,75	4,45	16,70	18,20	11,80	1,60	1,60	12,0	0,70	PHC 08B-1SS...
10B-1SS	15,88	10,16	9,65	5,08	19,50	20,90	14,70	1,70	1,70	14,5	0,94	PHC 10B-1SS...
12B-1SS	19,05	12,07	11,68	5,72	22,50	24,20	16,00	1,85	1,85	18,5	1,16	PHC 12B-1SS...
16B-1SS	25,40	15,88	17,02	8,28	36,10	37,40	21,00	4,15	3,10	40,0	2,73	PHC 16B-1SS...
20B-1SS	31,75	19,05	19,56	10,19	41,30	45,00	26,40	4,50	3,50	59,0	3,73	PHC 20B-1SS...
24B-1SS	38,10	25,40	25,40	14,63	53,40	57,80	33,20	6,00	4,80	104,0	7,20	PHC 24B-1SS...
32B-1SS	50,80	29,21	30,99	17,81	66,00	71,00	42,00	7,00	6,00	150,0	10,22	PHC 32B-1SS...

* Bushing chain: d₁ indicates external diameter of bushing

^ Straight side plates

Standard lengths are 10 ft and 5 m. To complete designation add chain length. For example, a 5 m box of 80-1SS is PHC 80-1SSX5MTR.

For links add "C/L" for "connecting" and "O/L" for "offset" to the designation in the table



Roller chains

Plated

Dacrotised, Nickel, Zinc

- ▶ Belts
- ▶ Chains
- ▶ Couplings
- ▶ Bushings and Hubs
- ▶ Sprockets
- ▶ Pulleys
- ▶ Smart tools

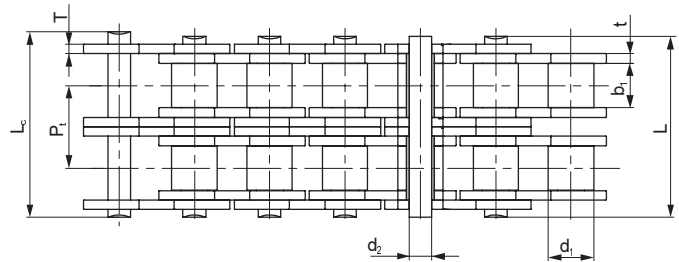
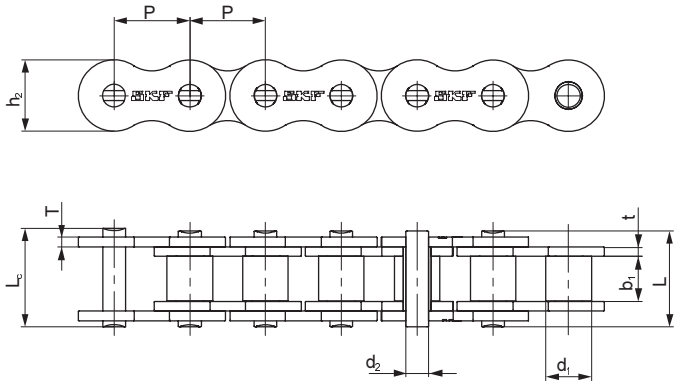

Plated chains are available Dacrotised, or with Nickel or Zinc plating.

Dacrotised	Suitable for corrosive conditions
Nickel-plated	Improved wear resistance Recommended for outdoor conditions such as exposure to rain
Zinc-plated	An economical way to increase corrosion resistance

Stainless steel should be used in food processing applications, (-20 to 400°C) and in highly corrosive environments.

Chain No.	Pitch	Roller diameter	Width between inner plates	Pin diameter	Pin length		Inner plate height	Plate thickness		Ultimate tensile strength	Weight per meter	Designation
	P	d ₁ max	b ₁ max	d ₂ max	L max	L ₁ max	h ₂ max	t max	T max	Q min	q	
	mm	mm	mm	mm	mm	mm	mm	mm	mm	kN	kg/m	
25-1*	6,35	3,30	3,18	2,31	7,90	8,40	6,00	0,80	0,80	3,5	0,15	PHC 25-1...
35-1*	9,53	5,08	4,77	3,58	12,40	13,17	9,00	1,30	1,30	7,9	0,33	PHC 35-1...
40-1	12,70	7,95	7,85	3,96	16,60	17,80	12,00	1,50	1,50	14,1	0,62	PHC 40-1...
41-1	12,70	7,77	6,25	3,58	13,75	15,00	9,91	1,30	1,30	6,7	0,41	PHC 41-1...
50-1	15,88	10,16	9,40	5,08	20,70	22,20	15,09	2,03	2,03	22,2	1,02	PHC 50-1...
60-1	19,05	11,91	12,57	5,94	25,90	27,70	18,00	2,42	2,42	31,8	1,50	PHC 60-1...
80-1	25,40	15,88	15,75	7,92	32,70	35,00	24,00	3,25	3,25	56,7	2,60	PHC 80-1...
100-1	31,75	19,05	18,90	9,53	40,40	44,70	30,00	4,00	4,00	88,5	3,91	PHC 100-1...
120-1	38,10	22,23	25,22	11,10	50,30	54,30	35,70	4,80	4,80	127,0	5,62	PHC 120-1...
140-1	44,45	25,40	25,22	12,70	54,40	59,00	41,00	5,60	5,60	172,4	7,50	PHC 140-1...
160-1	50,80	28,58	31,55	14,27	64,80	69,60	47,80	6,40	6,40	226,8	10,10	PHC 160-1...
04B-1	6,00	4,00	2,80	1,85	6,80	7,80	5,00	0,60	0,60	3,0	0,11	PHC 04B-1...
05B-1	8,00	5,00	3,00	2,31	8,20	8,90	7,10	0,80	0,80	5,0	0,20	PHC 05B-1...
06B-1^	9,53	6,35	5,72	3,28	13,15	14,10	8,20	1,30	1,30	9,0	0,41	PHC 06B-1...
08B-1	12,70	8,51	7,75	4,45	16,70	18,20	11,80	1,60	1,60	18,0	0,69	PHC 08B-1...
10B-1	15,88	10,16	9,65	5,08	19,50	20,90	14,70	1,70	1,70	22,4	0,93	PHC 10B-1...
12B-1	19,05	12,07	11,68	5,72	22,50	24,20	16,00	1,85	1,85	60,0	1,15	PHC 12B-1...
16B-1	25,40	15,88	17,02	8,28	36,10	37,40	21,00	4,15	3,10	95,0	2,71	PHC 16B-1...
20B-1	31,75	19,05	19,56	10,19	41,30	45,00	26,40	4,50	3,50	95,0	3,70	PHC 20B-1...
24B-1	38,10	25,40	25,40	14,63	53,40	57,80	33,20	6,00	4,80	160,0	7,10	PHC 24B-1...
28B-1	44,45	27,94	30,99	15,90	65,10	69,50	36,70	7,50	6,00	200,0	8,50	PHC 28B-1...
32B-1	50,80	29,21	30,99	17,81	66,00	71,00	42,00	7,00	6,00	250,0	10,25	PHC 32B-1 ...

* Bushing chain: d₁ indicates external diameter of bushing

^ Straight side plates

Note: Duplex and double pitch plated chains are available in all sizes

When ordering plated chains suffix the Chain No. according to material selection:

- DR = Dacrotised**
- NP = Nickel-plated**
- ZP = Zinc-plated**

For example: PHC 50-1DR... 50-1 ANSI Simplex **Dacrotised** chain
 PHC 60-2NP... 60-2 ANSI Duplex **Nickel-plated** chain
 PHC 10B-1ZP... 10B-1 BS/ISO Simplex **Zinc-plated** chain

Standard lengths are 10 ft and 5 m. To complete designation add chain length.

For example, a 10 ft box of 12B-1DR is PHC 12B-1DRX10FT

For links add "C/L" for "connecting" and "O/L" for "offset" to the designation in the table



Roller chains

Side bow

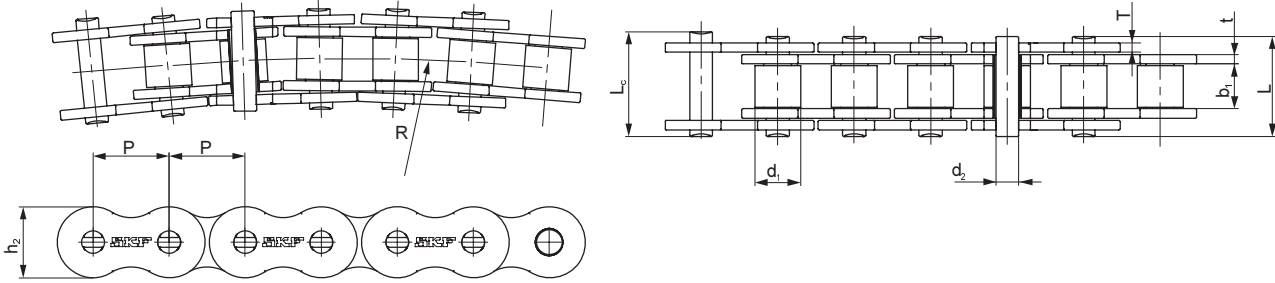

Chain No.	Pitch	Roller diameter	Width between inner plates	Pin diameter	Pin length		Inner plate height	Plate thickness		Side bow radius	Ultimate tensile strength	Average tensile strength	Weight per meter	Designation
	P	d ₁ max	b ₁ min	d ₂ max	L max	L _c max	h ₂ max	t max	T max	R min	Q min	Q ₀	q	
	mm	mm	mm	mm	mm	mm	mm	mm	mm	mm	kN	kN	kg/m	
40-1SB	12,70	7,95	7,85	3,96	16,9	18,1	11,7	1,50	1,50	350	13,8	15,2	0,80	PHC 40-1SB...
43-1SB	12,70	7,95	7,85	3,45	18,3	19,5	11,7	1,50	1,50	305	12,0	13,2	0,64	PHC 43-1SB...
50-1SB	15,88	10,16	9,40	4,37	20,7	22,7	14,9	2,03	2,03	400	20,6	22,7	1,09	PHC 50-1SB...
60-1SB	19,05	11,91	12,57	5,34	26,6	28,4	18,0	2,42	2,42	500	15,7	17,3	1,54	PHC 60-1SB...
63-1SB	19,05	11,91	12,68	5,08	28,8	30,6	17,2	2,42	2,03	350	12,5	20,0	1,40	PHC 63-1SB...
80-1SB	25,40	15,88	15,75	7,19	34,0	37,3	24,0	3,25	3,25	711	40,9	42,0	2,60	PHC 80-1SB...
08B-1SB	12,70	8,51	7,75	3,97	17,4	18,7	11,8	1,60	1,60	400	14,0	15,4	0,70	PHC 08B-1SB...
10B-1SB	15,88	10,16	9,65	4,50	20,1	21,5	14,7	1,70	1,70	400	15,6	17,2	0,93	PHC 10B-1SB...
12B-1SB	19,05	12,07	11,68	5,12	23,1	24,8	16,0	1,85	1,85	500	20,5	22,6	1,16	PHC 12B-1SB...
C2050-1SB	31,75	10,16	9,40	5,08	21,3	22,6	15,0	2,03	2,03	800	21,8	24,1	0,84	PHC C2050-1SB...

Standard lengths are 10 ft and 5 m. To complete designation add chain length. For example, a 5 m box of 60-1SB is PHC 60-1SBX5MTR. For links add "C/L" for "connecting" and "O/L" for "offset" to the designation in the table

Roller chains

Self-lubricating

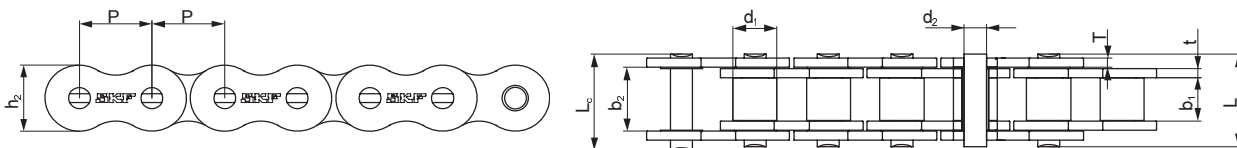

Chain No.	Pitch	Roller diameter	Width between inner plates	Width between outer plates	Pin diameter	Pin length		Inner plate height	Plate thickness		Ultimate tensile strength	Weight per meter	Designation
	P	d ₁ max	b ₁ min	b ₂ min	d ₂ max	L max	L _c max	h ₂ max	t max	T max	Q min	q	
	mm	mm	mm	mm	mm	mm	mm	mm	mm	mm	kN	kg/m	
08B-1SLR	12,70	8,51	7,75	13,03	4,45	16,7	18,2	11,8	1,60	1,60	18,0	0,69	PHC 08B-1SLR...
10B-1SLR	15,88	10,16	9,65	13,75	5,08	19,5	20,9	14,7	1,70	1,70	22,4	0,93	PHC 10B-1SLR...
12B-1SLR	19,05	12,07	11,68	15,75	5,72	22,5	24,2	16,0	1,85	1,85	29,0	1,15	PHC 12B-1SLR...
16B-1SLR	25,40	15,88	17,02	27,50	8,28	36,1	37,4	21,0	4,15	3,10	60,0	2,71	PHC 16B-1SLR...
12B-2SLR	19,05	12,07	11,68	35,21	5,72	42,0	43,6	16,0	1,85	1,85	58,0	2,31	PHC 12B-2SLR...
16B-2SLR	25,40	15,88	17,02	57,46	8,28	68,0	69,3	21,0	4,15	3,10	106,0	5,42	PHC 16B-2SLR...
50-1SLR	15,88	10,16	9,40	13,84	5,08	20,7	22,2	15,1	2,03	2,03	21,8	1,02	PHC 50-1SLR...
60-1SLR	19,05	11,91	12,57	19,35	5,94	27,5	29,3	18,0	2,42	2,42	34,2	1,65	PHC 60-1SLR...
80-1SLR	25,40	15,88	15,75	22,66	7,92	32,7	35,0	24,0	3,25	3,25	56,7	2,60	PHC 80-1SLR...
100-1SLR	31,75	19,05	18,90	27,51	9,53	40,4	44,7	30,0	4,00	4,00	86,7	3,94	PHC 100-1SLR...
60-2SLR	19,05	11,91	12,57	42,13	5,94	50,3	52,1	18,0	3,25	2,42	68,4	3,21	PHC 60-2SLR...

Standard lengths are 10 ft and 5 m. To complete designation add chain length. For example, a 10 ft box of 10B-1SLR is PHC 10B-1SLRX10FT. For links add "C/L" for "connecting" and "O/L" for "offset" to the designation in the table

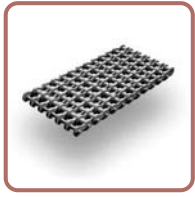

Oil field chains

- ▶ Belts
- ▶ Chains
- ▶ Couplings
- ▶ Bushings and Hubs
- ▶ Sprockets
- ▶ Pulleys
- ▶ Smart tools

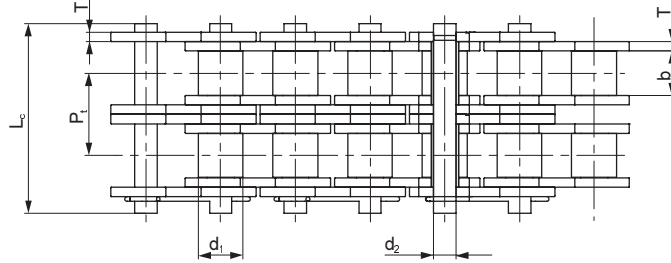
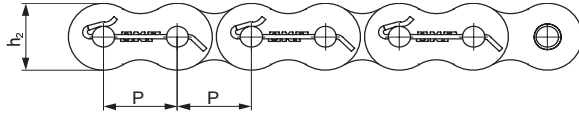

Chain No.	ANSI Chain No.	Pitch	Roller diameter	Width between inner plates	Pin diameter	Pin length	Inner plate height	Plate thickness	Transverse pitch	Ultimate tensile strength	Weight per meter	Designation
		P	d ₁ max	b ₁ min	d ₂ max	L ₁ max	h ₂ max	T max	Pt	Q min	q	
		mm	mm	mm	mm	mm	mm	mm	mm	mm	kg/m	
165-1	80-1	25,40	15,88	15,75	7,92	37,55	24,1	3,25	-	55,6	2,60	PHC 165-1...
205-1	100-1	31,75	19,05	18,90	9,53	44,30	30,0	4,00	-	86,9	3,91	PHC 205-1...
245-1	120-1	38,10	22,23	25,22	11,10	54,40	36,2	4,80	-	125,1	5,62	PHC 245-1...
285-1	140-1	44,45	25,40	25,22	12,70	59,00	42,2	5,60	-	170,3	7,50	PHC 285-1...
325-1	160-1	50,80	28,58	31,55	14,27	69,60	48,2	6,40	-	222,4	10,10	PHC 325-1...
365-1	180-1	57,15	35,71	35,48	17,46	78,60	54,3	7,20	-	281,5	13,45	PHC 365-1...
405-1	200-1	63,50	39,68	37,85	19,85	87,20	60,3	8,00	-	347,5	16,15	PHC 405-1...
165-2	80-2	25,40	15,88	15,75	7,92	66,80	24,1	3,25	29,29	111,2	5,15	PHC 165-2...
205-2	100-2	31,75	19,05	18,90	9,53	80,50	30,1	4,00	35,76	173,7	7,80	PHC 205-2...
245-2	120-2	38,10	22,23	25,22	11,10	99,70	36,2	4,80	45,44	250,2	11,70	PHC 245-2...
285-2	140-2	44,45	25,40	25,22	12,70	107,80	42,2	5,60	48,87	340,5	15,14	PHC 285-2...
325-2	160-2	50,80	28,58	31,55	14,27	127,50	48,2	6,40	58,55	444,8	20,14	PHC 325-2...
365-2	180-2	57,15	35,71	35,48	17,46	144,40	54,3	7,20	65,84	562,9	29,22	PHC 365-2...
405-2	200-2	63,50	39,68	37,85	19,85	158,80	60,3	8,00	71,55	695,0	32,24	PHC 405-2...
165-3	80-3	25,40	15,88	15,75	7,92	96,10	24,1	3,25	29,29	166,8	7,89	PHC 165-3...
205-3	100-3	31,75	19,05	18,90	9,53	116,30	30,1	4,00	35,76	260,6	11,77	PHC 205-3...
245-3	120-3	38,10	22,23	25,22	11,10	145,20	36,2	4,80	45,44	375,3	17,53	PHC 245-3...
285-3	140-3	44,45	25,40	25,22	12,70	156,80	42,2	5,60	48,87	510,8	22,20	PHC 285-3...
325-3	160-3	50,80	28,58	31,55	14,27	186,60	48,2	6,40	58,55	667,2	30,02	PHC 325-3...
365-3	180-3	57,15	35,71	35,48	17,46	210,20	54,3	7,20	65,84	844,4	38,22	PHC 365-3...
405-3	200-3	63,50	39,68	37,85	19,85	230,40	60,3	8,00	71,55	1042,5	49,03	PHC 405-3...
165-4	80-4	25,40	-	15,75	7,92	122,90	24,1	3,25	29,29	222,4	10,24	PHC 165-4...
205-4	100-4	31,75	19,05	18,90	9,53	151,50	30,1	4,00	35,76	347,5	15,39	PHC 205-4...
245-4	120-4	38,10	22,23	25,22	11,10	190,60	36,2	4,80	45,44	500,4	22,19	PHC 245-4...
285-4	140-4	44,45	25,40	25,22	12,70	205,70	42,2	5,60	48,87	681,1	29,63	PHC 285-4...
325-4	160-4	50,80	28,58	31,55	14,27	245,20	48,2	6,40	58,55	889,6	39,94	PHC 325-4...
405-4	200-4	63,50	39,68	37,85	19,85	302,00	60,3	8,00	71,55	1390,0	63,60	PHC 405-4...
165-5	80-5	25,40	-	15,75	7,92	152,20	24,1	3,25	29,29	278,0	12,79	PHC 165-5...
205-5	100-5	31,75	19,05	18,90	9,53	187,80	30,1	4,00	35,76	434,4	19,22	PHC 205-5...
245-5	120-5	38,10	22,23	25,22	11,10	236,10	36,2	4,80	45,44	625,5	27,71	PHC 245-5...
165-6	80-6	25,40	15,88	15,75	7,92	181,50	24,1	3,25	29,29	333,6	15,34	PHC 165-6...
205-6	100-6	31,75	19,05	18,90	9,53	223,60	30,1	4,00	35,76	521,2	23,05	PHC 205-6...
245-6	120-6	38,10	22,23	25,22	11,10	281,60	36,2	4,80	45,44	750,6	33,24	PHC 245-6...
285-6	140-6	44,45	25,40	25,22	12,70	303,40	42,2	5,60	48,87	1021,6	44,38	PHC 285-6...
325-6	160-6	50,80	28,58	31,55	14,27	362,30	48,2	6,40	58,55	1334,4	59,83	PHC 325-6...
405-6	200-6	63,50	39,68	37,85	19,85	445,00	60,3	8,00	71,55	2085,0	95,23	PHC 405-6...
165-8	80-8	25,40	15,88	15,75	7,92	240,10	24,1	3,25	29,29	444,8	20,44	PHC 165-8...
205-8	100-8	31,75	19,05	18,90	9,53	295,10	30,1	4,00	35,76	695,0	30,71	PHC 205-8...
245-8	120-8	38,10	22,23	25,22	11,10	372,40	36,2	4,80	45,44	1000,8	44,28	PHC 245-8...

Standard lengths are 10 ft. To complete designation add chain length. For example, a 10 ft box of 405-6 is PHC 405-6X10FT
 For links add "C/L" for "connecting" and "O/L" for "offset" to the designation in the table



Double pitch chains

Transmission

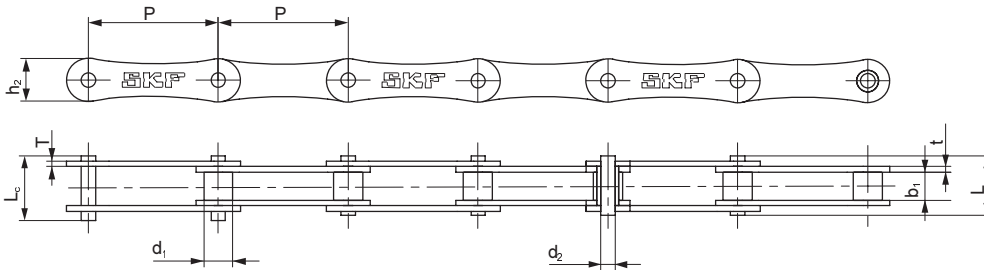

ANSI Chain No.	BS/ISO Chain No.	Pitch	Roller diameter	Width between inner plates	Pin diameter	Pin length		Inner plate height	Plate thickness		Ultimate tensile strength	Average tensile strength	Weight per meter	Designation	
		P	d ₁ max	b ₁ min	d ₂ max	L max	L _c max	h ₂ max	t max	T max	Q min	Q ₀	q		
		mm	mm	mm	mm	mm	mm	mm	mm	mm	kN	kN	kg/m		
2040	208A	25,40	7,95	7,85	3,96	16,6	17,8	12,0	1,50	1,50	14,1	16,7	0,42	PHC 2040...	
2050	210A	31,75	10,16	9,40	5,08	20,7	22,2	15,0	2,03	2,03	22,2	28,1	0,73	PHC 2050...	
2060	212A	38,10	11,91	12,57	5,94	25,9	27,7	18,0	2,42	2,42	31,8	36,8	1,02	PHC 2060...	
2080	216A	50,80	15,88	15,75	7,92	32,7	36,5	24,0	3,25	3,25	56,7	65,7	1,70	PHC 2080...	
2100	220A	63,50	19,05	18,90	9,53	40,4	44,7	30,0	4,00	4,00	88,5	102,6	2,55	PHC 2100...	
2120	224A	76,20	22,23	25,22	11,10	50,3	54,3	35,7	4,80	4,80	127,0	147,3	4,06	PHC 2120...	
-	208B	25,40	8,51	7,75	4,45	16,7	18,2	11,8	1,60	1,60	18,0	19,4	0,45	PHC 208B...	
-	210B	31,75	10,16	9,65	5,08	19,5	20,9	14,7	1,70	1,70	22,4	27,5	0,65	PHC 210B...	
-	212B	38,10	12,07	11,68	5,72	22,5	25,2	16,0	1,85	1,85	29,0	32,2	0,76	PHC 212B...	
-	216B	50,80	15,88	17,02	8,28	36,1	39,1	21,0	4,15	3,10	60,0	72,8	1,75	PHC 216B...	
-	220B	63,50	19,05	19,56	10,19	41,3	45,0	26,4	4,50	3,50	95,0	106,7	2,62	PHC 220B...	
-	224B	76,20	25,40	25,40	14,63	53,4	57,8	33,2	6,00	4,80	160,0	178,0	4,70	PHC 224B...	
-	228B	88,90	27,94	30,99	15,90	65,1	69,5	36,7	7,50	6,00	200,0	222,0	6,23	PHC 228B...	
-	232B	101,60	29,21	30,99	17,81	66,0	71,0	42,0	7,00	6,00	250,0	277,5	6,72	PHC 232B...	

Standard lengths are 10 ft and 5 m. To complete designation add chain length. For example, a 5 m box of 2060 is PHC 2060X5MTR. For links add "C/L" for "connecting" and "O/L" for "offset" to the designation in the table

Double pitch chains

Transmission attachments



ANSI Chain No.	BS/ISO Chain No.	P	G	F ₁	W	h ₄	d ₄	C	F ₂	d ₅	Designation
		mm	mm	mm	mm	mm	mm	mm	mm	mm	
2040	208A	25,40	19,1	25,4	39,6	9,1	3,4	11,1	20,5	5,5	PHC 2040...
2050	210A	31,75	23,8	31,8	49,0	11,1	5,5	14,3	25,0	6,6	PHC 2050...
2060	212A	38,10	28,6	42,9	67,8	14,7	5,5	17,5	32,9	9,2	PHC 2060...
2080	216A	50,80	38,1	55,6	87,8	19,1	6,8	22,2	43,5	11,0	PHC 2080...
2100	220A	63,50	47,6	66,6	107,5	23,4	9,2	28,6	50,4	13,0	PHC 2100...
2120	224A	76,20	57,2	79,3	121,4	27,8	10,5	33,3	55,5	15,0	PHC 2120...
-	208B	25,40	23,2	25,4	39,6	9,1	4,5	11,1	20,5	5,5	PHC 208B...
-	210B	31,75	23,8	31,8	49,0	11,1	5,5	-	-	-	PHC 210B...
-	212B	38,10	35,0	38,1	57,0	14,7	6,6	-	-	-	PHC 212B...
-	216B	50,80	44,0	50,8	84,0	19,1	6,6	-	-	-	PHC 216B...
-	220B	63,50	52,0	63,5	104,0	23,4	8,4	-	-	-	PHC 220B...
-	224B	76,20	60,0	76,2	120,0	27,8	10,5	-	-	-	PHC 224B...

To complete designation add attachment spacing and type followed by chain length. For example: PHC 2060-L1K1X10FT (2060 chain with K-1 attachment on every link, 10 ft length)

Note: Also available in stainless steel. When ordering suffix with SS, for example: PHC 2060SS-L1K1X10FT
For links add "C/L" for "connecting" and "O/L" for "offset" to the designation in the table

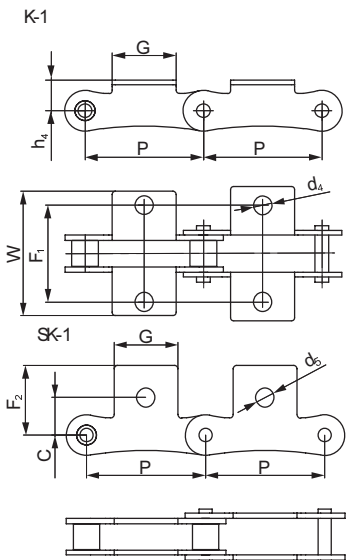



Double pitch chains

Conveyor

- ▶ Belts
- ▶ Chains
- ▶ Couplings
- ▶ Bushings and Hubs
- ▶ Sprockets
- ▶ Pulleys
- ▶ Smart tools

Small roller type

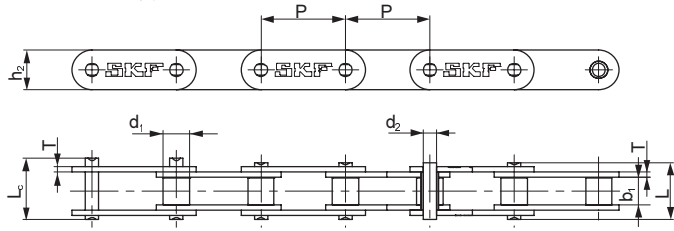

Large roller type

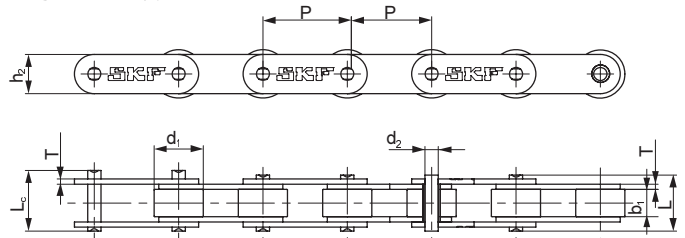

ANSI Chain No.	BS/ISO Chain No.	Pitch	Roller diameter	Width between inner plates	Pin diameter	Pin length		Inner plate height	Plate thickness	Ultimate tensile strength	Average tensile strength	Weight per meter	Designation	
						L max	Lc max							
		P	d1 max	b1 min	d2 max	L max	Lc max	h2 max	T max	Q min	Q0	q		
		mm	mm	mm	mm	mm	mm	mm	mm	kN	kN	kg/m		
C2040	C208A	25,40	7,95	7,85	3,96	16,6	17,8	12,0	1,50	14,1	16,7	0,50	PHC C2040...	
C2042	C208AL	25,40	15,88	7,85	3,96	16,6	17,8	12,0	1,50	14,1	16,7	0,84	PHC C2042...	
C2040H	C208AH	25,40	7,95	7,85	3,96	18,8	19,9	12,0	2,03	14,1	17,2	0,65	PHC C2040H...	
C2050	C210A	31,75	10,16	9,40	5,08	20,7	22,2	15,0	2,03	22,2	28,1	0,78	PHC C2050...	
C2052	C210AL	31,75	19,05	9,40	5,08	20,7	22,2	15,0	2,03	22,2	28,1	1,27	PHC C2052...	
C2060	C212A	38,10	11,91	12,57	5,94	25,9	27,7	18,0	2,42	31,8	36,8	1,12	PHC C2060...	
C2062	C212AL	38,10	22,23	12,57	5,94	25,9	27,7	18,0	2,42	31,8	36,8	1,61	PHC C2062...	
C2060H	C212AH	38,10	11,91	12,57	5,94	29,2	31,6	18,0	3,25	31,8	41,6	1,44	PHC C2060H...	
C2062H	C212AHL	38,10	22,23	12,57	5,94	29,2	31,6	18,0	3,25	31,8	41,6	2,07	PHC C2062H...	
C2080	C216A	50,80	15,88	15,75	7,92	32,7	36,5	24,0	3,25	56,7	65,7	2,08	PHC C2080...	
C2082	C216AL	50,80	28,58	15,75	7,92	32,7	36,5	24,0	3,25	56,7	65,7	3,12	PHC C2082...	
C2080H	C216AH	50,80	15,88	15,75	7,92	36,2	39,4	24,0	4,00	56,7	70,0	2,54	PHC C2080H...	
C2082H	C216AHL	50,80	28,58	15,75	7,92	36,2	39,4	24,0	4,00	56,7	70,0	3,58	PHC C2082H...	
C2100	C220A	63,50	19,05	18,90	9,53	40,4	44,7	30,0	4,00	88,5	102,6	3,01	PHC C2100...	
C2102	C220AL	63,50	39,67	18,90	9,53	40,4	44,7	30,0	4,00	88,5	102,6	4,83	PHC C2102...	
C2100H	C220AH	63,50	19,05	18,90	9,53	43,6	46,9	30,0	4,80	88,5	112,4	3,56	PHC C2100H...	
C2102H	C220AHL	63,50	39,67	18,90	9,53	43,6	46,9	30,0	4,80	88,5	112,4	5,38	PHC C2102H...	
C2120	C224A	76,20	22,23	25,22	11,10	50,3	54,3	35,7	4,80	127,0	147,3	4,66	PHC C2120...	
C2122	C224AL	76,20	44,45	25,22	11,10	50,3	54,3	35,7	4,80	127,0	147,3	7,66	PHC C2122...	
C2120H	C224AH	76,20	22,23	25,22	11,10	53,5	57,5	35,7	5,60	127,0	160,9	5,26	PHC C2120H...	
C2122H	C224AHL	76,20	44,45	25,22	11,10	53,5	57,5	35,7	5,60	127,0	160,9	8,26	PHC C2122H...	
C2160	C232A	101,60	28,58	31,75	14,27	64,8	69,6	47,8	6,40	226,8	278,9	8,15	PHC C2160...	
C2162	C232AL	101,60	57,15	31,75	14,27	64,8	69,6	47,8	6,40	226,8	278,9	13,00	PHC C2162...	
C2160H	C232AH	101,60	28,58	31,75	14,27	68,2	73,0	47,8	7,20	226,8	285,8	9,06	PHC C2160H...	
C2162H	C232AHL	101,60	57,15	31,75	14,27	68,2	73,0	47,8	7,20	226,8	285,8	12,77	PHC C2162H...	

Standard lengths are 10 ft and 5 m. To complete designation add chain length. For example, a 5 m box of 2060-1 is PHC C2060X5MTR. For links add "C/L" for "connecting" and "O/L" for "offset" to the designation in the table



Double pitch chains



Conveyor attachments

A-1, A-2, K-1, K-2, AA-1, AA-2, KK-1, KK-2, SA-1, SA-2, SK-1, SK-2

A-1, A-2, K-1, K-2

ANSI Chain No.	BS/ISO Chain No.	P	G	L	F	W	h_4	d_4	Designation
		mm	mm	mm	mm	mm	mm	mm	
C2040	C208A	25,4	19,1	9,5	25,4	39,6	9,1	3,4	PHC C2040...
C2042	C208AL	25,4	19,1	9,5	25,4	39,6	9,1	3,4	PHC C2042...
C2050	C210A	31,8	23,8	11,9	31,8	49,0	11,1	5,5	PHC C2050...
C2052	C210AL	31,8	23,8	11,9	31,8	49,0	11,1	5,5	PHC C2052...
C2060	C212A	38,1	28,6	14,3	42,9	67,8	14,7	5,5	PHC C2060...
C2062	C212AL	38,1	28,6	14,3	42,9	67,8	14,7	5,5	PHC C2062...
C2060H	C212AH	38,1	28,6	14,3	42,9	67,8	14,7	5,5	PHC C2060H...
C2062H	C212AHL	38,1	28,6	14,3	42,9	67,8	14,7	5,5	PHC C2062H...
C2080	C216A	50,8	38,1	19,1	55,6	87,8	19,1	6,8	PHC C2080...
C2082	C216AL	50,8	38,1	19,1	55,6	87,8	19,1	6,8	PHC C2082...
C2080H	C216AH	50,8	38,1	19,1	55,6	87,8	19,1	6,8	PHC C2080H...
C2082H	C216AHL	50,8	47,6	19,1	55,6	87,8	19,1	6,8	PHC C2082H...
C2100	C220A	63,5	47,6	23,8	66,6	107,5	23,4	9,2	PHC C2100...
C2102	C220AL	63,5	47,6	23,8	66,6	107,5	23,4	9,2	PHC C2102...
C2100H	C220AH	63,5	47,6	23,8	66,6	107,5	23,4	9,2	PHC C2100H...
C2102H	C220AHL	63,5	47,6	23,8	66,6	107,5	23,4	9,2	PHC C2102H...
C2120	C224A	76,2	57,2	28,6	79,3	121,4	27,8	11,0	PHC C2120...
C2122	C224AL	76,2	57,2	28,6	79,3	121,4	27,8	11,0	PHC C2122...
C2120H	C224AH	76,2	57,2	28,6	79,3	121,4	27,8	11,0	PHC C2120H...
C2122H	C224AHL	76,2	57,2	28,6	79,3	121,4	27,8	11,0	PHC C2122H...
C2160	C232A	101,6	76,2	38,1	104,7	151,6	36,5	13,1	PHC C2160...
C2162	C232AL	101,6	76,2	38,1	104,7	151,6	36,5	13,1	PHC C2162...
C2160H	C232AH	101,6	76,2	38,1	104,7	151,6	36,5	13,1	PHC C2160H...
C2162H	C232AHL	101,6	76,2	38,1	104,7	151,6	36,5	13,1	PHC C2162H...

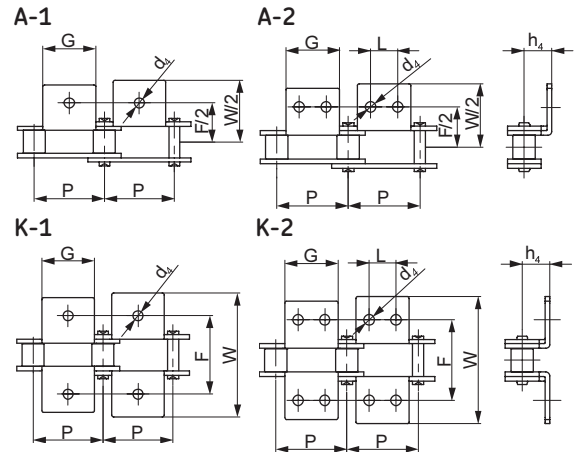

To complete designation add attachment spacing and type followed by chain length.

For example: PHC C2060-L2A1X10FT (C2060 with A-1 attachment on every second link, 10 ft length)

Note: Also available in stainless steel. When ordering suffix with SS, for example: PHC C2060SS-L2A1X10FT

AA-1, AA-2, KK-1, KK-2

ANSI Chain No.	BS/ISO Chain No.	P	G	L	F	W	h_4	d_4	Designation
		mm	mm	mm	mm	mm	mm	mm	
C2040	C208A	25,4	19,1	9,5	25,4	39,6	9,1	3,4	PHC C2040...
C2042	C208AL	25,4	19,1	9,5	25,4	39,6	9,1	3,4	PHC C2042...
C2050	C210A	31,8	23,8	11,9	31,8	49,0	11,1	5,5	PHC C2050...
C2052	C210AL	31,8	23,8	11,9	31,8	49,0	11,1	5,5	PHC C2052...
C2060	C212A	38,1	28,6	14,3	42,9	67,8	14,7	5,5	PHC C2060...
C2062	C212AL	38,1	28,6	14,3	42,9	67,8	14,7	5,5	PHC C2062...
C2060H	C212AH	38,1	28,6	14,3	42,9	67,8	14,7	5,5	PHC C2060H...
C2062H	C212AHL	38,1	28,6	14,3	42,9	67,8	14,7	5,5	PHC C2062H...
C2080	C216A	50,8	38,1	19,1	55,6	87,8	19,1	6,8	PHC C2080...
C2082	C216AL	50,8	38,1	19,1	55,6	87,8	19,1	6,8	PHC C2082...
C2080H	C216AH	50,8	38,1	19,1	55,6	87,8	19,1	6,8	PHC C2080H...
C2082H	C216AHL	50,8	38,1	19,1	55,6	87,8	19,1	6,8	PHC C2082H...

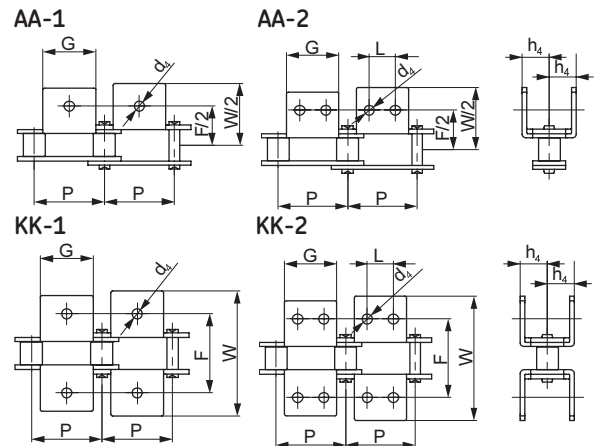

To complete designation add attachment spacing and type followed by chain length.

For example: PHC C2060-L4KK1X10FT (C2060 with KK-1 attachment on every fourth link, 10 ft length)

Note: Also available in stainless steel. When ordering suffix with SS, for example: PHC C2060SS-L4KK1X10FT

SA-1, SA-2, SK-1, SK-2

ANSI Chain No.	BS/ISO Chain No.	P	G	L	C_1	C_2	F	d_4	d_5	Designation
		mm	mm	mm	mm	mm	mm	mm	mm	
C2040	C208A	25,40	19,1	9,5	11,1	13,5	20,5	3,4	5,5	PHC C2040...
C2042	C208AL	25,40	19,1	9,5	11,1	13,5	20,5	3,4	5,5	PHC C2042...
C2050	C210A	31,75	23,8	11,9	14,3	15,9	25,0	5,5	6,6	PHC C2050...
C2052	C210AL	31,75	23,8	11,9	14,3	15,9	25,0	5,5	6,6	PHC C2052...
C2060	C212A	38,10	28,6	14,3	17,5	19,1	32,9	5,5	9,2	PHC C2060...
C2062	C212AL	38,10	28,6	14,3	17,5	19,1	32,9	5,5	9,2	PHC C2062...
C2060H	C212AH	38,10	28,6	14,3	17,5	19,1	32,9	5,5	9,2	PHC C2060H...
C2062H	C212AHL	38,10	28,6	14,3	17,5	19,1	32,9	5,5	9,2	PHC C2062H...
C2080	C216A	50,80	38,1	19,1	22,2	25,4	43,5	6,6	11,0	PHC C2080...
C2082	C216AL	50,80	38,1	19,1	22,2	25,4	43,5	6,6	11,0	PHC C2082...
C2080H	C216AH	50,80	38,1	19,1	22,2	25,4	43,5	6,6	11,0	PHC C2080H...
C2082H	C216AHL	50,80	38,1	19,1	22,2	25,4	43,5	6,6	11,0	PHC C2082H...
C2100	C220A	63,50	47,6	23,8	28,6	31,8	50,4	8,4	13,0	PHC C2100...
C2102	C220AL	63,50	47,6	23,8	28,6	31,8	50,4	8,4	13,0	PHC C2102...
C2100H	C220AH	63,50	47,6	23,8	28,6	31,8	50,4	8,4	13,0	PHC C2100H...
C2102H	C220AHL	63,50	47,6	23,8	28,6	31,8	50,4	8,4	13,0	PHC C2102H...

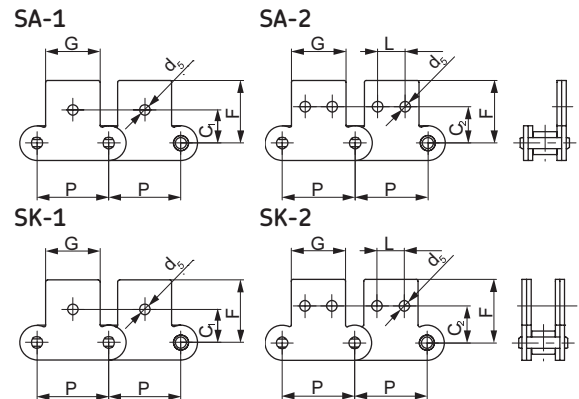

To complete designation add attachment spacing and type followed by chain length.

For example: PHC C2060-1-L5SK2X10FT (C2060-1 with SK-2 attachment on every fifth link, 10 ft length)

Note: Also available in stainless steel. When ordering suffix with SS, for example: PHC C2060-1SS-L5SK2X10FT



Conveyor chains

M Series

- ▶ Belts
- ▶ Chains
- ▶ Couplings
- ▶ Bushings and Hubs
- ▶ Sprockets
- ▶ Pulleys
- ▶ Smart tools

without roller

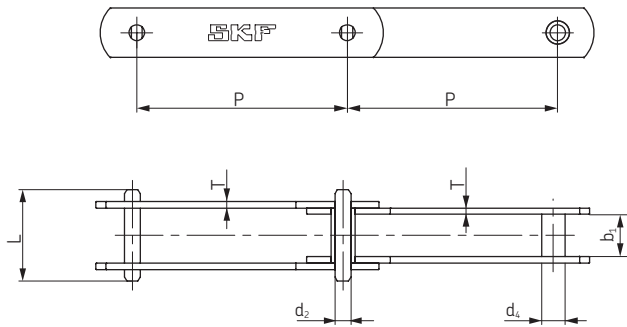

with P large roller

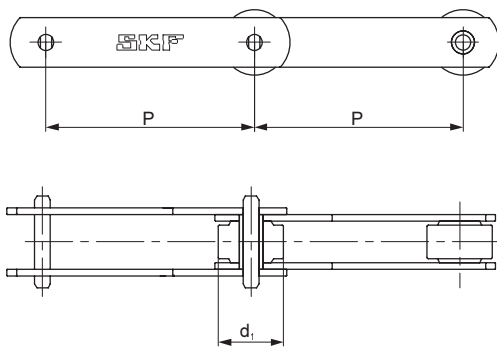

with S small roller

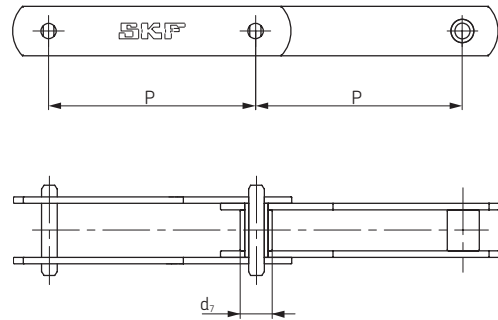

with F flanged roller

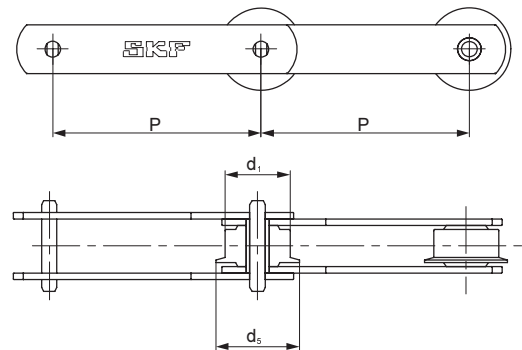

BS/ISO Chain No.	Pitch sizes available													
	P (mm)													
M20	40*	50	63	80	100	125	160	-	-	-	-	-	-	
M28	-	50*	63	80	100	125	160	200	-	-	-	-	-	
M40	-	-	63	80	100	125	160	200	250	-	-	-	-	
M56	-	-	63*	80	100	125	160	200	250	-	-	-	-	
M80	-	-	-	80	100	125	160	200	250	315	-	-	-	
M112	-	-	-	80*	100	125	160	200	250	315	400	-	-	
M160	-	-	-	-	100*	125	160	200	250	315	400	500	-	
M224	-	-	-	-	-	125*	160	200	250	315	400	500	630	
M315	-	-	-	-	-	-	160*	200	250	315	400	500	630	
M450	-	-	-	-	-	-	-	200	250	315	400	500	630	800

BS/ISO Chain No.	Roller diameter			Bush diameter	Width between inner plates	Pin diameter	Pin length	Plate height	Plate thickness	Ultimate tensile strength	Average tensile strength	Designation
	d ₁ max	d ₂ max	d ₃ max									
	mm	mm	mm									
M20A	25	12,5	32	9,0	16	6,0	35	19	2,5	20	25,0	PHC M20A...
M28A	30	15,0	36	10,0	18	7,0	40	21	3,0	28	35,0	PHC M28A...
M40A	36	18,0	42	12,5	20	8,5	45	26	3,5	40	50,0	PHC M40A...
M56A	42	21,0	50	15,0	24	10,0	52	31	4,0	56	70,0	PHC M56A...
M80A	50	25,0	60	18,0	28	12,0	62	36	5,0	80	100,0	PHC M80A...
M112A	60	30,0	70	21,0	32	15,0	73	41	6,0	112	140,0	PHC M112A...
M160A	70	36,0	85	25,0	37	18,0	85	51	7,0	160	200,0	PHC M160A...
M224A	85	42,0	100	30,0	43	21,0	98	62	8,0	224	280,0	PHC M224A...
M315A	100	50,0	120	36,0	48	25,0	112	72	10,0	315	393,7	PHC M315A...
M450A	120	60,0	140	42,0	56	30,0	135	82	12,0	450	562,5	PHC M450A...

* Only available with small roller or without roller

To complete designation add pitch and chain length. For example, to order M20A with a 50 mm pitch in a 5 m length, use designation PHC M20A50X5MTR



Engineering chains

Lumber and 3939 series

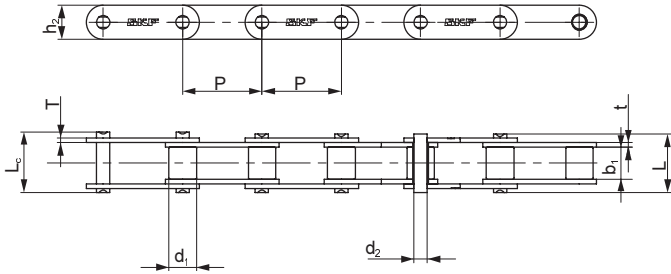

Chain No.	Pitch	Roller diameter	Width between inner plates	Pin diameter	Pin length		Inner plate height	Plate thickness		Ultimate tensile strength	Average tensile strength	Weight per meter	Designation
	P	d ₁ max	b ₁ max	d ₂ max	L max	L max	h ₂ max	t max	T max	Q min	Q ₀	q	
	mm	mm	mm	mm	mm	mm	mm	mm	mm	kN	kN	kg/m	
81X	66,27	23,0	27,00	11,10	49,0	53,5	28,50	4,00	4,00	106,7	128,9	3,78	PHC 81X...
81XH	66,27	23,0	27,78	11,10	60,7	65,1	31,35	7,94	5,55	151,9	175,7	5,88	PHC 81XH...
81XHH	66,27	23,0	27,78	11,10	65,6	70,0	31,35	7,94	7,94	191,1	212,6	6,70	PHC 81XHH...
81XHS	66,27	23,0	27,00	11,10	63,6	68,0	31,80	7,60	7,60	152,0	177,2	6,55	PHC 81XHS...
500R	50,00	25,4	25,40	14,63	52,0	56,4	40,00	5,00	5,00	100,0	114,5	7,13	PHC 500R...
441,100R	100,00	25,4	25,40	14,63	52,0	56,4	40,00	5,00	5,00	100,0	114,5	5,15	PHC 441.100R...

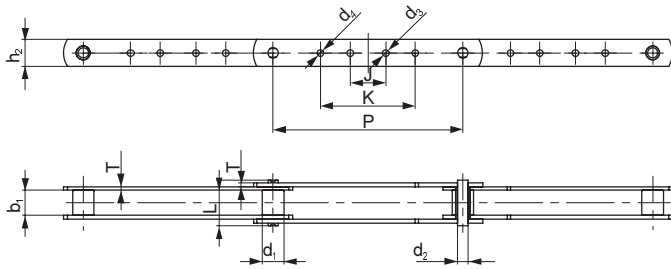

Chain No.	Pitch	Roller diameter	Width between inner plates	Pin dimensions		Plate dimensions					Plate thickness	Ultimate tensile strength	Average tensile strength	Weight per meter	Designation
	P	d ₁ max	b ₁ max	d ₂ max	L max	h ₂ max	d ₂ max	d ₄ max	J max	K max	T max	Q min	Q ₀	q	
	mm	mm	mm	mm	mm	mm	mm	mm	mm	mm	mm	kN	kN	kg/m	
3939-B4	203,2	23	27	11,1	49	28,58	7,2	7,2	38,1	101,6	4	115,58	136,5	2,45	PHC 3939-B4...
3939-B21	203,2	23	27	11,1	49	28,58	7,2	-	38,1	-	4	115,58	136,5	2,45	PHC 3939-B21...
3939-B23	203,2	23	27	11,1	49	28,58	-	10,3	-	92,1	4	115,58	136,5	2,45	PHC 3939-B23...
3939-B24	203,2	23	27	11,1	49	28,58	-	7,2	-	101,6	4	115,58	136,5	2,45	PHC 3939-B24...
3939-B40	203,2	23	27	11,1	49	28,58	-	10,3	-	101,6	4	115,58	136,5	2,45	PHC 3939-B40...
3939-B43	203,2	23	27	11,1	49	28,58	7,2	10,3	38,1	92,1	4	115,58	136,5	2,42	PHC 3939-B43...
3939-B44	203,2	23	27	11,1	49	28,58	7,2	10,3	38,1	101,6	4	115,58	136,5	2,45	PHC 3939-B44...



Silent chains

Flank contact

- ▶ Belts
- ▶ Chains
- ▶ Couplings
- ▶ Bushings and Hubs
- ▶ Sprockets
- ▶ Pulleys
- ▶ Smart tools

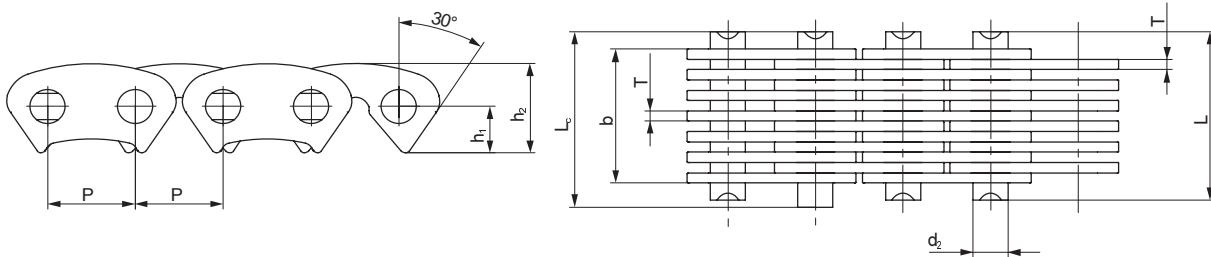

Chain No.	Pitch	Chain width	Pin diameter	Pin length		Distance from hole center to tooth	Plate height	Plate thickness	Guide form	Number of plates	Ultimate tensile strength	Average tensile strength	Weight per meter	Designation
	P			b min	d ₂ max						L max	L ₁ max		
	mm	mm	mm	mm	mm	mm	mm	mm	mm	n	kN	kN	kg/m	
CL06-13,5	9,53	13,5	3,95	18,5	20,0	5,3	10,0	1,5	Outside	9	10,0	11,2	0,60	PHC CL06-13.5...
CL06-16,5	9,53	16,5	3,95	21,5	23,0	5,3	10,0	1,5	Outside	11	12,5	14,0	0,73	PHC CL06-16.5...
CL06-19,5	9,53	19,5	3,95	24,5	26,0	5,3	10,0	1,5	Outside	13	15,0	16,8	0,85	PHC CL06-19.5...
CL06-22,5	9,53	22,5	3,95	27,5	29,0	5,3	10,0	1,5	Outside	15	17,5	19,6	1,00	PHC CL06-22.5...
CL06-28,5	9,53	28,5	3,95	33,5	35,0	5,3	10,0	1,5	Inside	19	22,5	25,2	1,26	PHC CL06-28.5...
CL08-19,5	12,70	19,5	5,08	24,5	26,0	7,0	13,4	1,5	Outside	13	23,4	26,2	1,15	PHC CL08-19.5...
CL08-22,5	12,70	22,5	5,08	27,5	29,0	7,0	13,4	1,5	Outside	15	27,4	30,6	1,33	PHC CL08-22.5...
CL08-25,5	12,70	25,5	5,08	30,5	32,0	7,0	13,4	1,5	Outside	17	31,3	35,0	1,50	PHC CL08-25.5...
CL08-28,5	12,70	28,5	5,08	33,5	35,0	7,0	13,4	1,5	Inside	19	35,2	39,4	1,68	PHC CL08-28.5...
CL08-34,5	12,70	34,5	5,08	39,5	41,0	7,0	13,4	1,5	Inside	23	43,0	48,1	2,04	PHC CL08-34.5...
CL08-40,5	12,70	40,5	5,08	45,5	47,0	7,0	13,4	1,5	Inside	27	50,8	56,8	2,39	PHC CL08-40.5...
CL08-46,5	12,70	46,5	5,08	51,5	53,0	7,0	13,4	1,5	Inside	31	58,6	65,6	2,74	PHC CL08-46.5...
CL08-52,5	12,70	52,5	5,08	57,5	59,0	7,0	13,4	1,5	Inside	35	66,4	74,3	3,10	PHC CL08-52.5...
CL10-30,0	15,88	30,0	5,92	37,0	38,2	8,7	16,7	2,0	Inside	15	45,6	50,6	2,21	PHC CL10-30.0...
CL10-38,0	15,88	38,0	5,92	45,0	46,2	8,7	16,7	2,0	Inside	19	58,6	65,0	2,80	PHC CL10-38.0...
CL10-46,0	15,88	46,0	5,92	53,0	54,2	8,7	16,7	2,0	Inside	23	71,7	79,5	3,39	PHC CL10-46.0...
CL10-54,0	15,88	54,0	5,92	61,0	62,4	8,7	16,7	2,0	Inside	27	84,7	94,0	3,99	PHC CL10-54.0...
CL10-62,0	15,88	62,0	5,92	69,0	70,4	8,7	16,7	2,0	Inside	31	97,7	108,4	4,58	PHC CL10-62.0...
CL12-38,0	19,05	38,0	6,90	45,0	46,5	10,5	20,0	2,0	Inside	19	70,0	77,6	3,37	PHC CL12-38.0...
CL12-46,0	19,05	46,0	6,90	53,0	54,5	10,5	20,0	2,0	Inside	23	86,0	95,4	4,08	PHC CL12-46.0...
CL12-54,0	19,05	54,0	6,90	61,0	62,8	10,5	20,0	2,0	Inside	27	102,0	113,2	4,78	PHC CL12-54.0...
CL12-62,0	19,05	62,0	6,90	69,0	70,8	10,5	20,0	2,0	Inside	31	117,0	129,8	5,50	PHC CL12-62.0...
CL12-70,0	19,05	70,0	6,90	77,0	78,8	10,5	20,0	2,0	Inside	35	133,0	147,6	6,20	PHC CL12-70.0...
CL16-45,0	25,40	45,0	8,90	52,0	53,5	14,0	26,7	3,0	Inside	15	111,0	123,2	5,31	PHC CL16-45.0...
CL16-51,0	25,40	51,0	8,90	58,0	59,5	14,0	26,7	3,0	Inside	17	125,0	138,7	6,02	PHC CL16-51.0...
CL16-57,0	25,40	57,0	8,90	64,0	65,5	14,0	26,7	3,0	Inside	19	141,0	156,5	6,37	PHC CL16-57.0...
CL16-69,0	25,40	69,0	8,90	76,2	77,7	14,0	26,7	3,0	Inside	23	172,0	190,9	8,15	PHC CL16-69.0...
CL16-81,0	25,40	81,0	8,90	88,2	89,7	14,0	26,7	3,0	Inside	27	203,0	225,3	9,57	PHC CL16-81.0...
CL16-93,0	25,40	93,0	8,90	100,2	101,7	14,0	26,7	3,0	Inside	31	235,0	260,8	10,98	PHC CL16-93.0...
CL20-57,0	31,75	57,0	10,84	66,6	69,6	17,5	33,4	3,0	Inside	19	165,0	183,1	8,42	PHC CL20-57.0...
CL20-69,0	31,75	69,0	10,84	78,6	81,6	17,5	33,4	3,0	Inside	23	201,0	223,1	10,19	PHC CL20-69.0...
CL20-81,0	31,75	81,0	10,84	90,6	93,6	17,5	33,4	3,0	Inside	27	237,0	263,2	11,96	PHC CL20-81.0...
CL20-93,0	31,75	93,0	10,84	102,6	105,6	17,5	33,4	3,0	Inside	31	273,0	303,0	13,73	PHC CL20-93.0...
CL20-105,0	31,75	105,0	10,84	114,6	117,6	17,5	33,4	3,0	Inside	35	310,0	341,0	15,50	PHC CL20-105.0...
CL20-117,0	31,75	117,0	10,84	126,6	129,6	17,5	33,4	3,0	Inside	39	346,0	380,6	17,27	PHC CL20-117.0...



Silent chains

Crotch contact

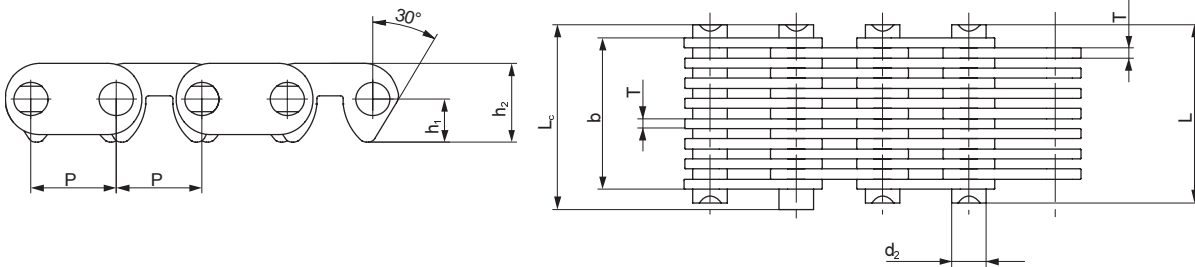

Chain No.	Pitch		Chain width	Pin diameter		Pin length		Distance from hole center to tooth			Plate height	Plate thickness	Guide form	Number of plates	Ultimate tensile strength	Average tensile strength	Weight per meter	Designation
	P	b min		d ₂ max	L max	L _c max	h ₁ max	h ₂ max	T max	Q min					Q ₀	q		
	mm	mm		mm	mm	mm	mm	mm	mm	n					kN	kN		
C4-120	12,7	19,5	5,08	24,5	26	6,62	12,1	1,5	Inside	13	20,0	22,2	1,20	PHC C4-120...				
C4-123	12,7	22,5	5,08	27,5	29	6,62	12,1	1,5	Inside	15	23,0	25,5	1,37	PHC C4-123...				
C4-129	12,7	28,5	5,08	33,5	35	6,62	12,1	1,5	Inside	19	28,5	31,6	1,72	PHC C4-129...				
C4-132	12,7	31,5	5,08	35,5	38	6,62	12,1	1,5	Inside	21	31,5	34,9	1,89	PHC C4-132...				
C4-138	12,7	37,5	5,08	42,5	44	6,62	12,1	1,5	Inside	25	38,0	42,1	2,22	PHC C4-138...				
C4-150	12,7	49,5	5,08	54,5	56	6,62	12,1	1,5	Inside	33	50,0	55,5	2,90	PHC C4-150...				
C4-320	12,7	19,5	5,08	24,5	26	6,62	12,1	1,5	Outside	13	20,0	22,2	1,21	PHC C4-320...				
C4-323	12,7	22,5	5,08	27,5	29	6,62	12,1	1,5	Outside	15	23,0	25,5	1,38	PHC C4-323...				
C4-329	12,7	28,5	5,08	33,5	35	6,62	12,1	1,5	Outside	19	28,5	31,6	1,73	PHC C4-329...				
C4-332	12,7	31,5	5,08	36,5	38	6,62	12,1	1,5	Outside	21	31,5	34,9	1,90	PHC C4-332...				
C4-338	12,7	37,5	5,08	42,5	44	6,62	12,1	1,5	Outside	25	38,0	42,1	2,23	PHC C4-338...				



Leaf chains

ANSI BL422-BL888

- ▶ Belts
- ▶ Chains
- ▶ Couplings
- ▶ Bushings and Hubs
- ▶ Sprockets
- ▶ Pulleys
- ▶ Smart tools

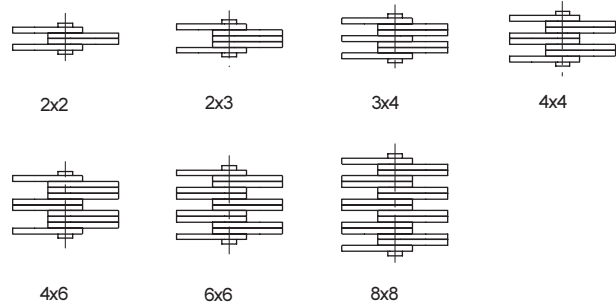
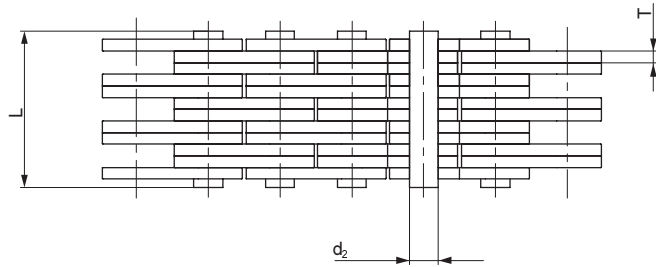
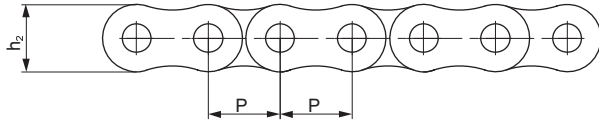

ANSI Chain No.	BS/ISO Chain No.	Pitch P	Plate lacing	Plate height	Plate thickness	Pin diameter	Pin length	Ultimate tensile strength	Average tensile strength	Weight per meter	Designation
				h_2 max	T max	d_2 max	L max	Q min	Q_0	q	
				mm	mm	mm	mm	kN	kN	kg/m	
BL422	LH0822	12,70	2 x 2	12,07	2,08	5,09	11,05	22,2	27,6	0,64	PHC BL422...
BL423	LH0823	12,70	2 x 3	12,07	2,08	5,09	13,16	22,2	27,6	0,80	PHC BL423...
BL434	LH0834	12,70	3 x 4	12,07	2,08	5,09	17,40	33,4	41,4	1,12	PHC BL434...
BL444	LH0844	12,70	4 x 4	12,07	2,08	5,09	19,51	44,5	56,0	1,28	PHC BL444...
BL446	LH0846	12,70	4 x 6	12,07	2,08	5,09	23,75	44,5	56,0	1,60	PHC BL446...
BL466	LH0866	12,70	6 x 6	12,07	2,08	5,09	27,99	66,7	81,7	1,92	PHC BL466...
BL488	LH0888	12,70	8 x 8	12,07	2,08	5,09	36,45	89,0	109,4	2,56	PHC BL488...
BL522	LH1022	15,88	2 x 2	15,09	2,44	5,96	12,90	33,4	43,1	0,88	PHC BL522...
BL523	LH1023	15,88	2 x 2	15,09	2,44	5,96	15,37	33,4	43,1	1,10	PHC BL523...
BL534	LH1034	15,88	3 x 4	15,09	2,44	5,96	20,32	48,9	65,6	1,50	PHC BL534...
BL544	LH1044	15,88	4 x 4	15,09	2,44	5,96	22,78	66,7	84,5	1,80	PHC BL544...
BL546	LH1046	15,88	4 x 6	15,09	2,44	5,96	27,74	66,7	84,5	2,20	PHC BL546...
BL566	LH1066	15,88	6 x 6	15,09	2,44	5,96	32,69	100,1	125,1	2,65	PHC BL566...
BL588	LH1088	15,88	8 x 8	15,09	2,44	5,96	42,57	133,4	169,5	3,50	PHC BL588...
BL622	LH1222	19,05	2 x 2	18,11	3,30	7,94	17,37	48,9	63,6	1,45	PHC BL622...
BL623	LH1223	19,05	2 x 3	18,11	3,30	7,94	20,73	48,9	63,6	1,80	PHC BL623...
BL634	LH1234	19,05	3 x 4	18,11	3,30	7,94	27,43	75,6	102,8	2,50	PHC BL634...
BL644	LH1244	19,05	4 x 4	18,11	3,30	7,94	30,78	97,9	120,9	2,90	PHC BL644...
BL646	LH1246	19,05	4 x 6	18,11	3,30	7,94	37,49	97,9	120,9	3,60	PHC BL646...
BL666	LH1266	19,05	6 x 6	18,11	3,30	7,94	44,20	146,8	190,8	4,30	PHC BL666...
BL688	LH1288	19,05	8 x 8	18,11	3,30	7,94	57,61	195,7	238,8	5,80	PHC BL688...
BL822	LH1622	25,40	2 x 2	24,13	4,09	9,54	21,34	84,5	108,2	2,20	PHC BL822...
BL823	LH1623	25,40	2 x 3	24,13	4,09	9,54	25,48	84,5	108,2	2,70	PHC BL823...
BL834	LH1634	25,40	3 x 4	24,13	4,09	9,54	33,76	129,0	170,0	3,80	PHC BL834...
BL844	LH1644	25,40	4 x 4	24,13	4,09	9,54	37,90	169,0	214,6	4,30	PHC BL844...
BL846	LH1646	25,40	4 x 6	24,13	4,09	9,54	46,18	169,0	214,6	5,40	PHC BL846...
BL866	LH1666	25,40	6 x 6	24,13	4,09	9,54	54,46	253,6	324,5	6,50	PHC BL866...
BL888	LH1688	25,40	8 x 8	24,13	4,09	9,54	71,02	338,1	432,7	8,60	PHC BL888...



Leaf chains

ANSI BL1022-BL2088

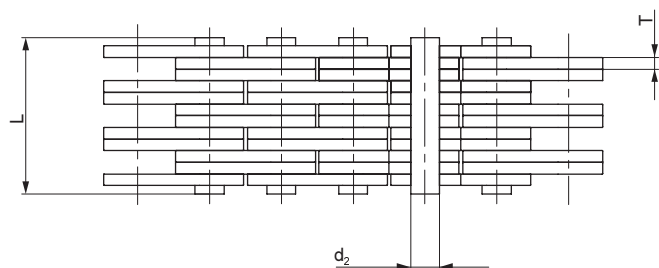
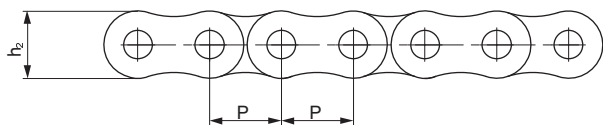

2x2



2x3



3x4



4x4



4x6

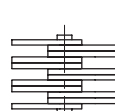

6x6



8x8

ANSI Chain No.	BS/ISO Chain No.	Pitch	Plate lacing	Plate height	Plate thickness	Pin diameter	Pin length	Ultimate tensile strength	Average tensile strength	Weight per meter	Designation
				h_2 max	T max	d_2 max	L max	Q min	Q_0	q	
		P		mm	mm	mm	mm	kN	kN	kg/m	
BL1022	LH2022	31,75	2 x 2	30,18	4,90	11,11	25,37	115,6	150,8	3,4	PHC BL1022...
BL1023	LH2023	31,75	2 x 3	30,18	4,90	11,11	30,33	115,6	150,8	4,3	PHC BL1023...
BL1034	LH2034	31,75	3 x 4	30,18	4,90	11,11	40,23	182,4	231,6	6,0	PHC BL1034...
BL1044	LH2044	31,75	4 x 4	30,18	4,90	11,11	45,19	231,3	291,4	6,9	PHC BL1044...
BL1046	LH2046	31,75	4 x 6	30,18	4,90	11,11	55,09	231,3	291,4	8,6	PHC BL1046...
BL1066	LH2066	31,75	6 x 6	30,18	4,90	11,11	65,00	347,0	430,3	10,3	PHC BL1066...
BL1088	LH2088	31,75	8 x 8	30,18	4,90	11,11	84,81	462,6	555,1	13,8	PHC BL1088...
BL1222	LH2422	38,10	2 x 2	36,20	5,77	12,71	29,62	151,2	192,0	4,6	PHC BL1222...
BL1223	LH2423	38,10	2 x 3	36,20	5,77	12,71	35,43	151,2	192,0	5,8	PHC BL1223...
BL1234	LH2434	38,10	3 x 4	36,20	5,77	12,71	47,07	244,6	315,9	8,1	PHC BL1234...
BL1244	LH2444	38,10	4 x 4	36,20	5,77	12,71	52,88	302,5	381,1	9,3	PHC BL1244...
BL1246	LH2446	38,10	4 x 6	36,20	5,77	12,71	64,52	302,5	381,1	11,6	PHC BL1246...
BL1266	LH2466	38,10	6 x 6	36,20	5,77	12,71	76,15	453,7	543,6	13,9	PHC BL1266...
BL1288	LH2488	38,10	8 x 8	36,20	5,77	12,71	99,42	605,0	726,0	18,6	PHC BL1288...
BL1422	LH2822	44,45	2 x 2	42,24	6,55	14,29	33,55	191,3	225,7	6,1	PHC BL1422...
BL1423	LH2823	44,45	2 x 3	42,24	6,55	14,29	40,16	191,3	225,7	7,6	PHC BL1423...
BL1434	LH2834	44,45	3 x 4	42,24	6,55	14,29	53,37	315,8	372,6	10,6	PHC BL1434...
BL1444	LH2844	44,45	4 x 4	42,24	6,55	14,29	59,97	382,6	451,2	12,2	PHC BL1444...
BL1446	LH2846	44,45	4 x 6	42,24	6,55	14,29	73,18	382,6	451,2	15,2	PHC BL1446...
BL1466	LH2866	44,45	6 x 6	42,24	6,55	14,29	86,39	578,3	682,4	18,2	PHC BL1466...
BL1488	LH2888	44,45	8 x 8	42,24	6,55	14,29	112,80	765,1	902,8	24,3	PHC BL1488...
BL1622	LH3222	50,80	2 x 2	48,26	7,52	17,46	39,01	289,1	341,1	8,0	PHC BL1622...
BL1623	LH3223	50,80	2 x 3	48,26	7,52	17,46	46,58	289,1	341,1	10,0	PHC BL1623...
BL1634	LH3234	50,80	3 x 4	48,26	7,52	17,46	61,72	440,4	519,6	14,0	PHC BL1634...
BL1644	LH3244	50,80	4 x 4	48,26	7,52	17,46	69,29	573,8	680,4	16,0	PHC BL1644...
BL1646	LH3246	50,80	4 x 6	48,26	7,52	17,46	84,43	578,3	680,4	20,0	PHC BL1646...
BL1666	LH3266	50,80	6 x 6	48,26	7,52	17,46	99,57	857,4	1000,7	24,0	PHC BL1666...
BL1688	LH3288	50,80	8 x 8	48,26	7,52	17,46	129,84	1156,5	1364,6	32,0	PHC BL1688...
BL2022	LH4022	63,50	2 x 2	60,33	9,91	23,81	51,74	433,7	511,7	15,8	PHC BL2022...
BL2023	LH4023	63,50	2 x 3	60,33	9,91	23,81	61,70	433,7	511,7	19,8	PHC BL2023...
BL2034	LH4034	63,50	3 x 4	60,33	9,91	23,81	81,61	649,4	766,2	27,7	PHC BL2034...
BL2044	LH4044	63,50	4 x 4	60,33	9,91	23,81	91,57	867,4	1023,5	31,6	PHC BL2044...
BL2046	LH4046	63,50	4 x 6	60,33	9,91	23,81	111,48	867,4	1023,5	39,5	PHC BL2046...
BL2066	LH4066	63,50	6 x 6	60,33	9,91	23,81	131,39	1301,1	1535,2	47,4	PHC BL2066...
BL2088	LH4088	63,50	8 x 8	60,33	9,91	23,81	171,22	1734,8	2046,5	63,2	PHC BL2088...



Leaf chains

BS/ISO LL0822-LL4888

- ▶ Belts
- ▶ Chains
- ▶ Couplings
- ▶ Bushings and Hubs
- ▶ Sprockets
- ▶ Pulleys
- ▶ Smart tools

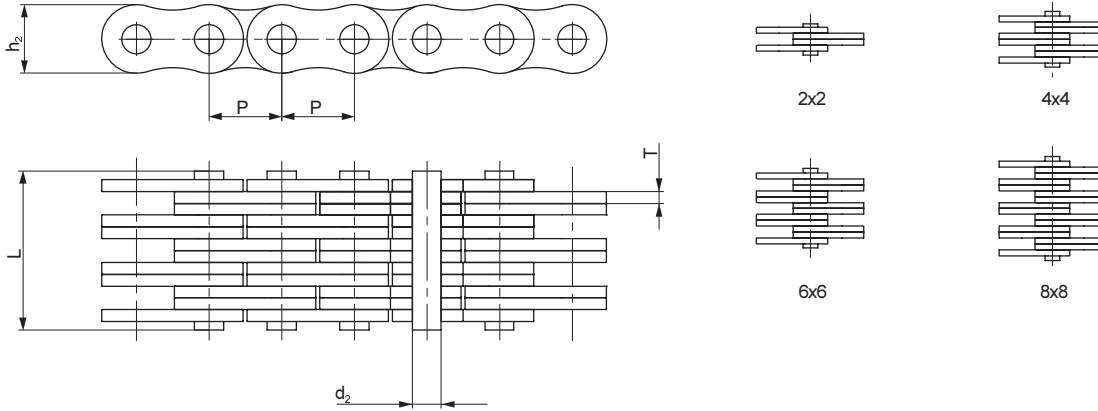

BS/ISO Chain No.	Pitch	Plate lacing	Plate height	Plate thickness	Pin diameter	Pin length	Ultimate tensile strength	Average tensile strength	Weight per meter	Designation
	P		h ₂ max	T max	d ₂ max	L max	Q min	Q ₀	q	
			mm	mm	mm	mm	mm	kN	kN	
LL0822	12,70	2 x 2	10,60	1,60	4,45	8,9	18,2	20,4	0,42	PHC LL0822...
LL0844	12,70	4 x 4	10,60	1,60	4,45	15,6	36,4	40,7	0,84	PHC LL0844...
LL0866	12,70	6 x 6	10,60	1,60	4,45	22,0	54,6	60,0	1,24	PHC LL0866...
LL0888	12,70	8 x 8	10,60	1,60	4,45	28,5	72,8	80,0	1,64	PHC LL0888...
LL1022	15,88	2 x 2	13,70	1,60	5,08	9,2	22,7	25,5	0,54	PHC LL1022...
LL1044	15,88	4 x 4	13,70	1,60	5,08	15,8	45,4	51,0	1,06	PHC LL1044...
LL1066	15,88	6 x 6	13,70	1,60	5,08	22,1	68,1	76,3	1,57	PHC LL1066...
LL1088	15,88	8 x 8	13,70	1,60	5,08	28,8	90,8	101,9	2,10	PHC LL1088...
LL1222	19,05	2 x 2	16,00	1,85	5,72	10,4	29,5	33,2	0,73	PHC LL1222...
LL1244	19,05	4 x 4	16,00	1,85	5,72	17,9	59,0	66,4	1,44	PHC LL1244...
LL1266	19,05	6 x 6	16,00	1,85	5,72	25,4	88,5	99,7	2,15	PHC LL1266...
LL1288	19,05	8 x 8	16,00	1,85	5,72	32,9	118,0	132,9	2,84	PHC LL1288...
LL1622	25,40	2 x 2	21,00	3,10	8,28	17,2	58,0	66,7	1,52	PHC LL1622...
LL1644	25,40	4 x 4	21,00	3,10	8,28	29,6	116,0	140,0	2,90	PHC LL1644...
LL1666	25,40	6 x 6	21,00	3,10	8,28	42,4	174,0	208,8	4,30	PHC LL1666...
LL1688	25,40	8 x 8	21,00	3,10	8,28	54,9	232,0	278,0	5,71	PHC LL1688...
LL2022	31,75	2 x 2	26,40	3,50	10,19	20,1	95,0	109,2	2,33	PHC LL2022...
LL2044	31,75	4 x 4	26,40	3,50	10,19	33,8	190,0	218,5	4,40	PHC LL2044...
LL2066	31,75	6 x 6	26,40	3,50	10,19	50,1	285,0	324,6	6,79	PHC LL2066...
LL2088	31,75	8 x 8	26,40	3,50	10,19	64,0	380,0	435,1	8,90	PHC LL2088...
LL2422	38,10	2 x 2	33,40	5,00	14,63	28,4	170,0	195,5	4,47	PHC LL2422...
LL2444	38,10	4 x 4	33,40	5,00	14,63	46,3	340,0	380,8	8,22	PHC LL2444...
LL2466	38,10	6 x 6	33,40	5,00	14,63	66,4	510,0	571,2	12,22	PHC LL2466...
LL2488	38,10	8 x 8	33,40	5,00	14,63	86,6	680,0	775,2	16,30	PHC LL2488...
LL2822	44,45	2 x 2	37,08	6,00	15,90	32,2	200,0	224,0	5,10	PHC LL2822...
LL2844	44,45	4 x 4	37,08	6,00	15,90	56,4	400,0	448,0	9,90	PHC LL2844...
LL2866	44,45	6 x 6	37,08	6,00	15,90	80,8	600,0	672,0	14,60	PHC LL2866...
LL2888	44,45	8 x 8	37,08	6,00	15,90	105,2	800,0	896,0	19,40	PHC LL2888...
LL3222	50,80	2 x 2	42,00	6,40	17,81	34,8	260,0	291,2	6,20	PHC LL3222...
LL3244	50,80	4 x 4	42,00	6,40	17,81	60,6	520,0	582,4	12,30	PHC LL3244...
LL3266	50,80	6 x 6	42,00	6,40	17,81	86,4	780,0	873,6	18,30	PHC LL3266...
LL3288	50,80	8 x 8	42,00	6,40	17,81	112,2	1040,0	1176,0	24,00	PHC LL3288...
LL4022	63,50	2 x 2	52,76	8,00	22,89	42,2	360,0	403,2	10,30	PHC LL4022...
LL4044	63,50	4 x 4	52,76	8,00	22,89	74,4	780,0	873,6	20,00	PHC LL4044...
LL4066	63,50	6 x 6	52,76	8,00	22,89	106,5	1080,0	1209,6	30,00	PHC LL4066...
LL4088	63,50	8 x 8	52,76	8,00	22,89	140,0	1440,0	1747,2	39,10	PHC LL4088...
LL4822	76,20	2 x 2	63,88	10,00	29,24	54,6	560,0	627,2	18,50	PHC LL4822...
LL4844	76,20	4 x 4	63,88	10,00	29,24	92,6	1120,0	1554,4	35,70	PHC LL4844...
LL4866	76,20	6 x 6	63,88	10,00	29,24	133,4	1680,0	1880,0	53,00	PHC LL4866...
LL4888	76,20	8 x 8	63,88	10,00	29,24	174,2	2240,0	2508,8	70,40	PHC LL4888...



Leaf chains

ANSI AL322-AL1688

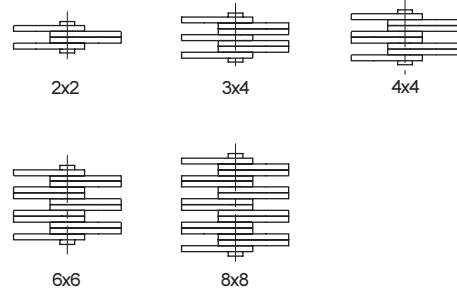
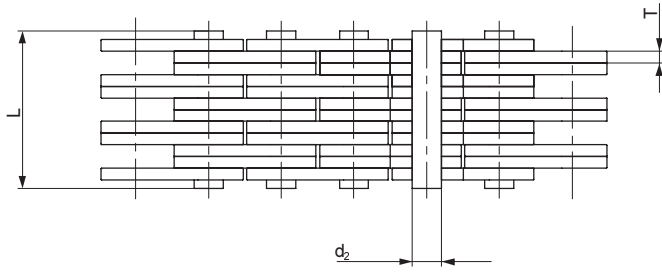
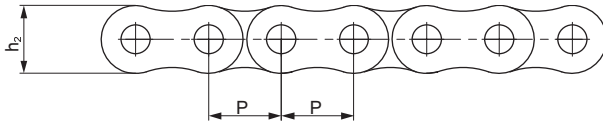

ANSI Chain No.	Pitch	Plate lacing	Plate height	Plate thickness	Pin diameter	Pin length	Ultimate tensile strength	Average tensile strength	Weight per meter	Designation
	P		h_2 max	T max	d_2 max	L max	Q min	Q_0	q	
			mm	mm	mm	mm	mm	kN	kN	
AL322	9,53	2 x 2	7,7	1,30	3,58	6,80	9,0	10,2	0,23	PHC AL322...
AL344	9,53	4 x 4	7,7	1,30	3,58	11,60	18,0	20,0	0,46	PHC AL344...
AL422	12,70	2 x 2	10,4	1,50	3,96	8,30	14,1	16,9	0,39	PHC AL422...
AL444	12,70	4 x 4	10,4	1,50	3,96	14,40	28,2	35,2	0,74	PHC AL444...
AL466	12,70	6 x 6	10,4	1,50	3,96	20,50	42,3	52,7	1,13	PHC AL466...
AL522	15,88	2 x 2	12,8	2,03	5,08	11,05	22,0	27,5	0,64	PHC AL522...
AL534	15,88	3 x 4	12,8	2,03	5,08	17,00	33,0	46,0	1,10	PHC AL534...
AL544	15,88	4 x 4	12,8	2,03	5,08	19,40	44,0	55,0	1,25	PHC AL544...
AL566	15,88	6 x 6	12,8	2,03	5,08	27,50	66,0	82,5	1,79	PHC AL566...
AL622	19,05	2 x 2	15,6	2,42	5,94	13,00	37,0	44,4	0,86	PHC AL622...
AL644	19,05	4 x 4	15,6	2,42	5,94	22,70	63,7	78,8	1,76	PHC AL644...
AL666	19,05	6 x 6	15,6	2,42	5,94	32,20	100,1	118,6	2,60	PHC AL666...
AL688	19,05	8 x 8	15,6	2,42	5,94	42,20	133,4	156,6	3,49	PHC AL688...
AL822	25,40	2 x 2	20,5	3,25	7,92	16,00	56,7	68,6	1,54	PHC AL822...
AL844	25,40	4 x 4	20,5	3,25	7,92	29,40	113,4	135,6	3,00	PHC AL844...
AL866	25,40	6 x 6	20,5	3,25	7,92	44,20	170,0	202,3	4,46	PHC AL866...
AL1022	31,75	2 x 2	25,6	4,00	9,53	19,60	88,5	107,1	2,37	PHC AL1022...
AL1044	31,75	4 x 4	25,6	4,00	9,53	36,40	177,0	203,6	4,68	PHC AL1044...
AL1066	31,75	6 x 6	25,6	4,00	9,53	52,30	265,0	315,3	7,20	PHC AL1066...
AL1088	31,75	8 x 8	25,6	4,00	9,53	68,50	354,0	421,2	9,94	PHC AL1088...
AL1222	38,10	2 x 2	30,5	4,80	11,10	24,30	127,0	151,1	3,65	PHC AL1222...
AL1244	38,10	4 x 4	30,5	4,80	11,10	43,80	254,0	299,7	7,05	PHC AL1244...
AL1266	38,10	6 x 6	30,5	4,80	11,10	63,20	381,0	426,3	10,50	PHC AL1266...
AL1288	38,10	8 x 8	30,5	4,80	11,10	82,60	508,0	568,4	14,03	PHC AL1288...
AL1444	44,45	4 x 4	36,4	5,60	12,64	51,30	372,7	413,6	10,34	PHC AL1444...
AL1466	44,45	6 x 6	36,4	5,60	12,64	74,56	559,0	620,4	15,16	PHC AL1466...
AL1644	50,80	4 x 4	41,6	6,40	14,21	58,00	471,0	522,8	12,98	PHC AL1644...
AL1666	50,80	6 x 6	41,6	6,40	14,21	83,80	706,0	783,6	19,76	PHC AL1666...
AL1688	50,80	8 x 8	41,6	6,40	14,21	109,50	942,0	1045,5	25,47	PHC AL1688...



Leaf chains

FL, F19V, FLC

- ▶ Belts
- ▶ Chains
- ▶ Couplings
- ▶ Bushings and Hubs
- ▶ Sprockets
- ▶ Pulleys
- ▶ Smart tools

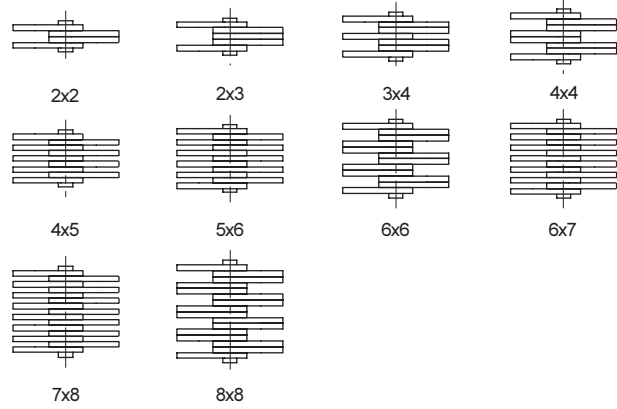
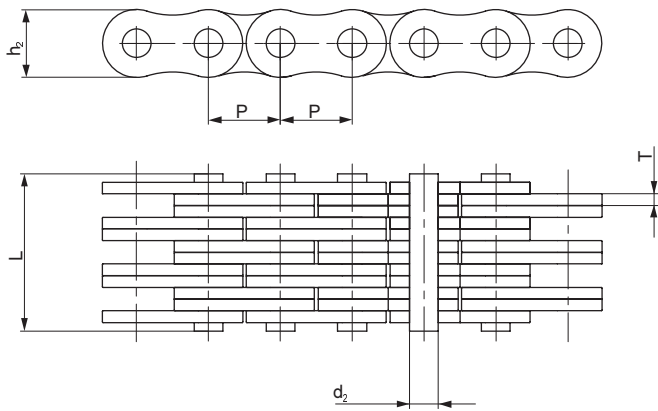

Chain No.	Pitch	Plate lacing	Plate height	Plate thickness	Pin diameter	Pin length	Ultimate tensile strength	Average tensile strength	Weight per meter	Designation
	P		h_2 max	T max	d_2 max	L max	Q min	Q_0	q	
	mm		mm	mm	mm	mm	kN	kN	kg/m	
FL644	5,94	4 x 4	4,7	0,60	1,85	6,6	6,50	7,8	0,13	PHC FL644...
FL666	5,94	6 x 6	4,7	0,60	1,85	9,3	9,75	11,8	0,20	PHC FL666...
FL688	5,94	8 x 8	4,7	0,60	1,85	12,0	13,00	15,6	0,25	PHC FL688...
FL844	8,00	4 x 4	6,9	0,73	2,31	7,9	10,00	12,1	0,25	PHC FL844...
FL944	9,53	4 x 4	8,7	1,04	3,28	10,4	21,00	24,7	0,43	PHC FL944...
FL966	9,53	6 x 6	8,7	1,00	3,28	14,9	31,00	36,8	0,65	PHC FL966...
F122	12,70	2 x 2	8,2	1,00	3,58	7,0	11,43	13,6	0,19	PHC F122...
F1223	12,70	2 x 3	10,2	2,03	4,45	12,8	20,00	23,8	0,61	PHC F1223...
FL1244	12,70	4 x 4	10,2	1,70	4,45	16,7	44,00	52,3	0,83	PHC FL1244...
F19V-44	19,05	4 x 4	15,2	2,42	6,50	22,4	71,00	84,3	1,73	PHC F19V-44...
F19V-66	19,05	6 x 6	15,2	2,42	6,50	32,3	106,00	125,9	2,57	PHC F19V-66...
FLC534	15,88	3 x 4	12,7	1,85	5,08	15,3	40,40	44,4	0,99	PHC FLC534...
FLC545	15,88	4 x 5	12,7	1,85	5,08	19,2	54,30	59,7	1,27	PHC FLC545...
FLC556	15,88	5 x 6	12,7	1,85	5,08	22,7	67,60	74,3	1,54	PHC FLC556...
FLC1056	31,75	5 x 6	25,4	3,25	9,53	40,6	137,90	151,0	5,44	PHC FLC1056...
FLC1067	31,75	6 x 7	25,4	3,25	9,53	47,2	165,40	181,9	6,42	PHC FLC1067...
FLC1078	31,75	7 x 8	25,4	3,25	9,53	53,8	193,00	212,0	7,40	PHC FLC1078...



Leaf chains

12XX, 15XX, 19XX, 25XX

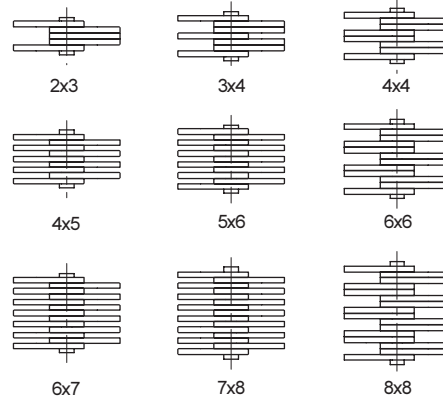
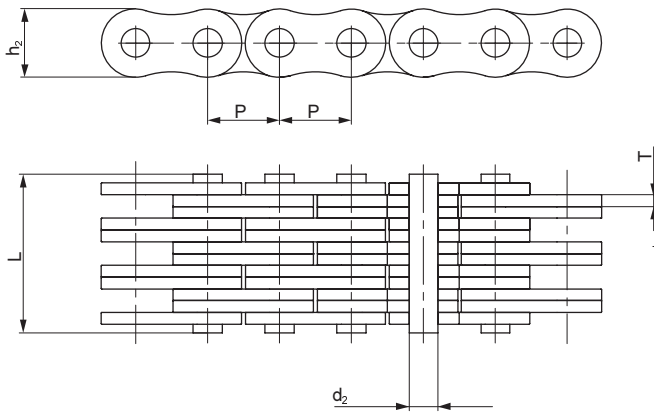

Chain No.	Pitch	Plate lacing	Plate height	Plate thickness	Pin diameter	Pin length	Chain length over 100 pitches +/- 0,25%	Ultimate tensile strength	Weight per meter	Designation
	P		h_2 max	T max	d_2 max	L max		Q min	q	
	mm		mm	mm	mm	mm		kN	kg/m	
1234	12,70	3 x 4	10,6	1,70	4,45	14,2	1262	31	0,75	PHC 1234...
1256	12,70	5 x 6	10,6	1,70	4,45	21,1	1262	53	1,17	PHC 1256...
1288	12,70	8 x 8	10,6	1,70	4,45	29,9	1262	85	1,70	PHC 1288...
1523	15,88	2 x 3	12,7	1,94	5,08	12,1	1580	29	0,75	PHC 1523...
1534	15,88	3 x 4	12,7	1,94	5,08	16,0	1580	46	1,04	PHC 1534...
1544	15,88	4 x 4	12,7	1,94	5,08	18,1	1580	58	1,18	PHC 1544...
1545	15,88	4 x 6	12,7	1,94	5,08	20,3	1580	58	1,33	PHC 1545...
1556	15,88	5 x 6	12,7	1,94	5,08	24,0	1580	72	1,63	PHC 1556...
1566	15,88	6 x 6	12,7	1,94	5,08	26,2	1580	87	1,77	PHC 1566...
1567	15,88	6 x 7	12,7	1,94	5,08	28,0	1580	90	1,91	PHC 1567...
1578	15,88	7 x 8	12,7	1,94	5,08	32,5	1580	101	2,20	PHC 1578...
1588	15,88	8 x 8	12,7	1,94	5,08	34,0	1580	115	2,34	PHC 1588...
1944	19,05	4 x 4	15,0	2,29	5,72	21,3	1891	73	1,58	PHC 1944...
1966	19,05	6 x 6	15,0	2,29	5,72	30,7	1891	110	2,37	PHC 1966...
1988	19,05	8 x 8	15,0	2,29	5,72	40,0	1891	140	3,13	PHC 1988...
2523	25,40	2 x 3	20,2	3,06	8,28	18,8	2532	72	1,83	PHC 2523...
2534	25,40	3 x 4	20,2	3,06	8,28	25,3	2532	108	2,55	PHC 2534...
2545	25,40	4 x 5	20,2	3,06	8,28	31,6	2532	144	3,26	PHC 2545...
2556	25,40	5 x 6	20,2	3,06	8,28	37,2	2532	180	3,96	PHC 2556...
2567	25,40	6 x 7	20,2	3,06	8,28	43,8	2532	216	4,68	PHC 2567...
2578	25,40	7 x 8	20,2	3,06	8,28	50,0	2532	252	5,39	PHC 2578...
2588	25,40	8 x 8	20,2	3,06	8,28	52,8	2532	290	5,77	PHC 2588...

Couplings





SKF Flex couplings

Selection



SKF Flex combines excellent vibration dampening and shock loading capacity with unrivaled misalignment accommodation to provide a high performance coupling solution.

Easy to install and maintenance free, SKF Flex is available with both bored to size (B) and taper bush mounting. Taper bush mounting includes face (F), hub (H) and a more versatile reversible option (R) that allows for the mounting orientation (F or H) to be decided at installation. SKF Flex flanges are phosphate coated for improved corrosion resistance. A complete coupling consists of 2 flanges and 1 tyre.

The addition of a standard sized spacer flange can be used to accommodate applications where it is advantageous to move either shaft axially without disturbing either driving or driven machines.

SKF Flex tyres are available in natural rubber compounds for use in ambient temperatures between -50 °C and +50 °C. Chloroprene rubber compounds are available for use in adverse operating conditions (e.g. oil or grease contamination) and can be used in temperatures of -15 °C to +70 °C. The Chloroprene component should be used where fire-resistance and antistatic (F.R.A.S.) properties are required.

Selection

Service Factor

- Determine the required service factor from the table below.

Design Power

- Multiply the normal running power by the service factor. This gives the design power for coupling selection.

Coupling Size

- Using the Power Ratings table read across from the appropriate speed until a power greater than the design power is found. The required SKF Flex coupling is given at the head of the column.

Bore Size

- Using the dimensions table check that chosen flanges can accommodate both driving and driven shafts.

Example

A SKF Flex coupling is required to transmit 30 kW from an Electric motor running at 1440 rev/min to a centrifugal pump for 14 hours per day. The motor shaft is 30 mm diameter and the pump shaft is 25 mm diameter. Taper bush is required.

1. Service factor

The appropriate service factor is 0,9.

2. Design Power

Design power = 30 x 0,9 = 27 kW

3. Coupling size

By reading across from the 1440 rev/min in the power ratings table the first power figure to exceed the required 27 kW in step(2) is 37,70 kW. The size of the coupling is 70 SKF Flex.

4. Bore Size

By referring to the dimensions table it can be seen that both shaft diameters fall within the bore range available. A note to make is that for this coupling size taper bush sizes differ between face and hub mounting.

Service Factors

		Type of driving unit: Electric motors and steam Turbines			Type of driving unit: Internal combustion engines, steam engines and water turbines		
		Duty hours per day			Duty hours per day		
		Up to 10	10 to 16	Over 16	Up to 10	10 to 16	Over 16
Light	Agitators/Mixers [liquids], belt conveyors [uniform loading], blowers and exhausters, centrifugal pumps and compressors, fans [below 7,5 kW]	0,8	0,9	1,0	1,3	1,4	1,5
Medium	Agitators/Mixers [non-liquid], Belt and chain conveyors [variable loading], fans [over 7,5 kW], generators, lines shafts, machine tools, rotary pumps and compressors [other than centrifugal] Machinery for food processing, laundries and printing industries	1,3	1,4	1,5	1,8	1,9	2,0
Heavy	Heavy duty conveyors [bucket, drag/shovel, screw], hammer mills, presses, punches, shears, piston pumps and compressors Machinery for brick, textile, paper, saw mill industries	1,8	1,9	2,0	2,3	2,4	2,5
Very Heavy	Crushers [gyratory, jaw, roll], Heavy duty mills [ball, rod, tube], Hoists	2,3	2,4	2,5	2,8	2,9	3,0

It is recommended that keys are fitted for applications where load fluctuation is expected



SKF Flex couplings

Selection

- ▶ Belts
- ▶ Chains
- ▶ Couplings
- ▶ Bushings and Hubs
- ▶ Sprockets
- ▶ Pulleys
- ▶ Smart tools

Power Ratings (kW)

Speed	Coupling Size														
	40	50	60	70	80	90	100	110	120	140	160	180	200	220	250
50	0,13	0,35	0,66	1,31	1,96	2,62	3,53	4,58	6,96	12,17	19,74	32,83	48,82	60,73	76,83
100	0,25	0,69	1,33	2,62	3,93	5,24	7,07	9,16	13,93	24,35	39,48	65,65	97,64	121,47	153,66
200	0,50	1,38	2,66	5,24	7,85	10,47	14,14	18,32	27,85	48,69	78,95	131,31	195,29	242,93	307,33
300	0,75	2,07	3,99	7,85	11,78	15,71	21,20	27,49	41,78	73,04	118,43	196,96	292,93	364,40	460,99
400	1,01	2,76	5,32	10,47	15,71	20,94	28,27	36,65	55,71	97,38	157,91	262,62	390,58	485,86	614,66
500	1,26	3,46	6,65	13,09	19,63	26,18	35,34	45,81	69,63	121,73	197,38	328,27	488,22	607,33	768,32
600	1,51	4,15	7,98	15,71	23,56	31,41	42,41	54,97	83,56	146,07	236,86	393,93	585,86	728,80	921,99
700	1,76	4,84	9,31	18,32	27,49	36,65	49,48	64,14	97,49	170,42	276,34	459,58	683,51	850,26	1075,65
720	1,81	4,98	9,57	18,85	28,27	37,70	50,89	65,97	100,27	175,29	284,23	472,71	703,04	874,55	1106,39
800	2,01	5,53	10,64	20,94	31,41	41,88	56,54	73,30	111,41	194,76	315,81	525,24	781,15	971,73	1229,32
900	2,26	6,22	11,97	23,56	35,34	47,12	63,61	82,46	125,34	219,11	355,29	590,89	878,80	1093,19	1382,98
960	2,41	6,63	12,77	25,13	37,70	50,26	67,85	87,96	133,70	233,72	378,97	630,28	937,38	1166,07	1475,18
1000	2,51	6,91	13,30	26,18	39,27	52,36	70,68	91,62	139,27	243,46	394,76	656,54	976,44	1214,66	1536,65
1200	3,02	8,29	15,96	31,41	47,12	62,83	84,82	109,95	167,12	292,15	473,72	787,85	1171,73	-	-
1400	3,52	9,68	18,62	36,65	54,97	73,30	98,95	128,27	194,97	340,84	552,67	919,16	-	-	-
1440	3,62	9,95	19,15	37,70	56,54	75,39	101,78	131,94	200,54	350,58	568,46	945,42	-	-	-
1600	4,02	11,06	21,28	41,88	62,83	83,77	113,09	146,60	222,83	389,53	631,62	-	-	-	-
1800	4,52	12,44	23,94	47,12	70,68	94,24	127,23	164,92	250,68	438,22	-	-	-	-	-
2000	5,03	13,82	26,60	52,36	78,53	104,71	141,36	183,25	278,53	-	-	-	-	-	-
2200	5,53	15,20	29,26	57,59	86,39	115,18	155,50	201,57	-	-	-	-	-	-	-
2400	6,03	16,59	31,92	62,83	94,24	125,65	169,63	-	-	-	-	-	-	-	-
2600	6,53	17,97	34,58	68,06	102,09	136,13	183,77	-	-	-	-	-	-	-	-
2800	7,04	19,35	37,24	73,30	109,95	146,60	-	-	-	-	-	-	-	-	-
2880	7,24	19,90	38,30	75,39	113,09	150,79	-	-	-	-	-	-	-	-	-
3000	7,54	20,73	39,90	78,53	117,80	157,07	-	-	-	-	-	-	-	-	-
3600	9,05	24,88	47,87	94,24	-	-	-	-	-	-	-	-	-	-	-
Nominal Torque Nm	24	66	127	250	375	500	675	875	1330	2325	3770	6270	9325	11600	14675
Max Torque Nm	64	160	318	487	759	1096	1517	2137	3547	5642	9339	16455	23508	33125	42740

Maximum torque figures should be treated as a short duration overload ratings occurring in circumstances such as direct-on-line starting.
For speeds not shown calculate the nominal torque for the design application using the formula below and select coupling according to nominal torque ratings.

$$\text{Nominal Torque (Nm)} = \frac{\text{Design power (kW)} \times 30000}{\text{RPM} \times \pi}$$

Physical Characteristics

Coupling Size	Maximum Speed	Mass	Inertia	Torsional Stiffness	Misalignment			Nominal Torque	Max Torque	Screw Size	Clamping Screw Torque (NM)	Tyre Designation	
					Angular	Parallel	Axial					Natural	F.R.A.S.
	RPM	kg	kg/m ²	Nm/°	°	mm	mm	Nm	Nm				
F40	4500	0,1	0,00074	5	4	1,1	1,3	24	64	M6	15	PHE F40NRTYRE	PHE F40FRTYRE
F50	4500	0,3	0,00115	13	4	1,3	1,7	66	160	M6	15	PHE F50NRTYRE	PHE F50FRTYRE
F60	4000	0,5	0,00520	26	4	1,6	2,0	127	318	M6	15	PHE F60NRTYRE	PHE F60FRTYRE
F70	3600	0,7	0,00900	41	4	1,9	2,3	250	487	M8	24	PHE F70NRTYRE	PHE F70FRTYRE
F80	3100	1,0	0,01700	63	4	2,1	2,6	375	759	M8	24	PHE F80NRTYRE	PHE F80FRTYRE
F90	3000	1,1	0,03100	91	4	2,4	3,0	500	1096	M10	40	PHE F90NRTYRE	PHE F90FRTYRE
F100	2600	1,1	0,05400	126	4	2,6	3,3	675	1517	M10	40	PHE F100NRTYRE	PHE F100FRTYRE
F110	2300	1,4	0,07800	178	4	2,9	3,7	875	2137	M10	40	PHE F110NRTYRE	PHE F110FRTYRE
F120	2050	2,3	0,01300	296	4	3,2	4,0	1330	3547	M12	50	PHE F120NRTYRE	PHE F120FRTYRE
F140	1800	2,6	0,25500	470	4	3,7	4,6	2325	5642	M12	55	PHE F140NRTYRE	PHE F140FRTYRE
F160	1600	3,4	0,38000	778	4	4,2	5,3	3770	9339	M16	80	PHE F160NRTYRE	PHE F160FRTYRE
F180	1500	7,7	0,84700	1371	4	4,8	6,0	6270	16455	M16	105	PHE F180NRTYRE	PHE F180FRTYRE
F200	1300	8,0	1,28100	1959	4	5,3	6,6	9325	23508	M16	120	PHE F200NRTYRE	PHE F200FRTYRE
F220	1100	10,0	2,10400	2760	4	5,8	7,3	11600	33125	M20	165	PHE F220NRTYRE	PHE F220FRTYRE
F250	1000	15,0	3,50500	3562	4	6,6	8,2	14675	42740	M20	165	PHE F250NRTYRE	PHE F250FRTYRE



SKF Flex couplings

Dimensions



Sizes 40-60

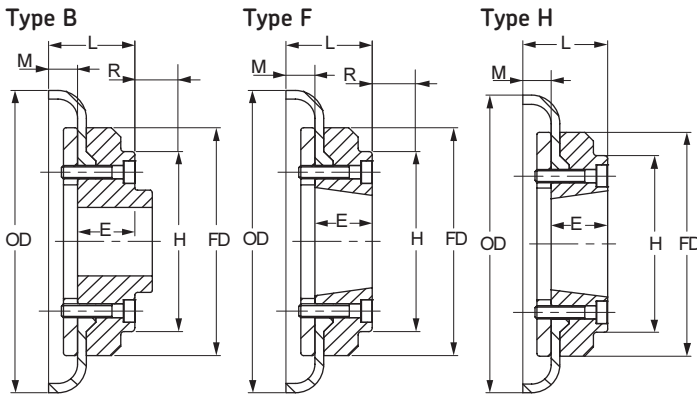

Sizes 70-250

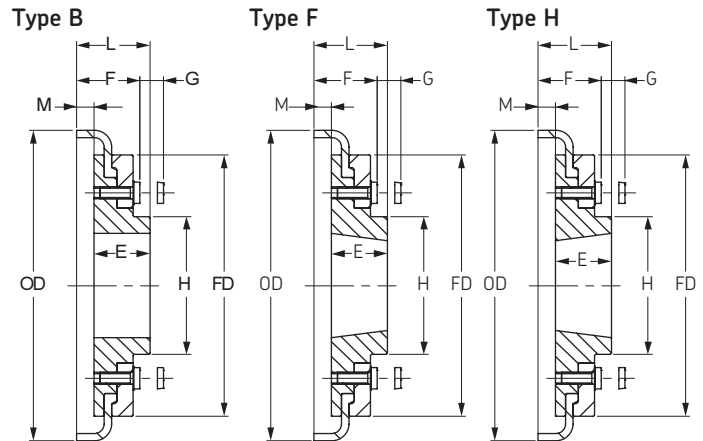

Dimensions of SKF Flex flanges types B, F & H

Size	Type	Bush No.	Bore		Types F & H		Type B		Key Screw	O.D	FD	H	F	R*	G+	M	Mass→	Inertia→	Designation
			Min	Max	L	E	L	E											
			mm	mm	mm	mm	mm	mm	mm	mm	mm	mm	mm	mm	mm	kg	kg/m ²		
40	F	1008	9	25	33,0	22	-	-	-	104	82,0	-	-	29	-	11,0	0,8	0,00074	PHE F40FTBFLG
40	H	1008	9	25	33,0	22	-	-	-	104	82,0	-	-	29	-	11,0	0,8	0,00074	PHE F40HTBFLG
40	B	-	-	30	-	-	33,0	22	M5	104	82,0	-	-	29	-	11,0	0,8	0,00074	PHE F40RSBFLG
50	F	1210	11	32	37,5	25	-	-	-	133	100,0	79	-	38	-	12,5	1,2	0,00115	PHE F50FTBFLG
50	H	1210	11	32	37,5	25	-	-	-	133	100,0	79	-	38	-	12,5	1,2	0,00115	PHE F50HTBFLG
50	B	-	-	38	-	-	45,0	32	M5	133	100,0	79	-	38	-	12,5	1,2	0,00115	PHE F50RSBFLG
60	F	1610	14	42	41,5	25	-	-	-	165	125,0	103	-	38	-	16,5	2,0	0,00520	PHE F60FTBFLG
60	H	1610	14	42	41,5	25	-	-	-	165	125,0	103	-	38	-	16,5	2,0	0,00520	PHE F60HTBFLG
60	B	-	-	45	-	-	55,0	38	M6	165	125,0	70	-	38	-	16,5	2,0	0,00520	PHE F60RSBFLG
70	F	2012	14	50	43,5	32	-	-	-	187	142,0	80	50	42	13	11,5	3,1	0,00900	PHE F70FTBFLG
70	H	1610	14	42	36,5	25	-	-	-	187	142,0	80	50	38	13	11,5	3,0	0,00900	PHE F70HTBFLG
70	B	-	-	60	-	-	47,0	35	M10	187	142,0	80	50	-	13	11,5	3,1	0,00900	PHE F70RSBFLG
80	F	2517	16	60	57,5	45	-	-	-	211	165,0	97	54	48	16	13,5	4,9	0,01800	PHE F80FTBFLG
80	H	2012	14	50	44,5	32	-	-	-	211	165,0	98	54	32	16	12,5	4,6	0,01700	PHE F80HTBFLG
80	B	-	-	63	-	-	55,0	42	M10	211	165,0	98	54	-	16	12,5	4,9	0,01800	PHE F80RSBFLG
90	F	2517	16	60	58,5	45	-	-	-	235	187,0	108	60	48	16	13,5	7,0	0,03100	PHE F90FTBFLG
90	H	2517	16	60	58,5	45	-	-	-	235	187,0	108	60	48	16	13,5	7,0	0,03100	PHE F90HTBFLG
90	B	-	-	75	-	-	62,5	49	M12	235	187,0	112	60	-	16	13,5	7,1	0,03200	PHE F90RSBFLG
100	B	-	-	80	-	-	69,5	56	M12	254	214,0	125	62	-	16	13,5	9,9	0,05500	PHE F100RSBFLG
100	F	3020	25	75	64,5	51	-	-	-	254	214,0	120	62	55	16	13,5	9,9	0,05500	PHE F100FTBFLG
100	H	2517	16	60	58,5	45	-	-	-	254	214,0	113	62	48	16	13,5	9,4	0,05400	PHE F100HTBFLG
110	B	-	-	90	-	-	75,5	63	M12	279	232,0	128	62	-	16	12,5	12,5	0,08100	PHE F110RSBFLG
110	F	3020	25	75	63,5	51	-	-	-	279	232,0	134	62	55	16	12,5	11,7	0,07800	PHE F110FTBFLG
110	H	3020	25	75	63,5	51	-	-	-	279	232,0	134	62	55	16	12,5	11,7	0,07800	PHE F110HTBFLG
120	B	-	-	100	-	-	84,5	70	M16	314	262,0	143	67	-	16	14,5	16,9	0,13700	PHE F120RSBFLG
120	F	3525	35	100	79,5	65	-	-	-	314	262,0	140	67	67	16	14,5	16,5	0,13700	PHE F120FTBFLG
120	H	3020	25	75	65,5	51	-	-	-	314	262,0	140	67	55	16	14,5	15,9	0,13000	PHE F120HTBFLG
140	B	-	-	125	-	-	110,5	94	M20	359	312,5	180	73	-	17	16,0	22,2	0,25400	PHE F140RSBFLG
140	F	3525	35	100	81,0	65	-	-	-	359	312,5	180	73	67	17	16,0	22,3	0,25500	PHE F140FTBFLG
140	H	3525	35	100	81,0	65	-	-	-	359	312,5	180	73	67	17	16,0	22,3	0,25500	PHE F140HTBFLG
160	B	-	-	140	-	-	117,0	102	M20	402	348,0	197	78	-	19	15,0	35,8	0,46900	PHE F160RSBFLG
160	F	4030	40	115	91,0	76	-	-	-	402	348,0	197	78	80	19	15,0	32,5	0,38000	PHE F160FTBFLG
160	H	4030	40	115	91,0	76	-	-	-	402	348,0	197	78	80	19	15,0	32,5	0,38000	PHE F160HTBFLG
180	B	-	-	150	-	-	137,0	114	M20	470	396,0	205	94	-	19	23,0	49,1	0,87100	PHE F180RSBFLG
180	F	4535	55	125	112,0	89	-	-	-	470	396,0	205	94	89	19	23,0	42,2	0,84700	PHE F180FTBFLG
180	H	4535	55	125	112,0	89	-	-	-	470	396,0	205	94	89	19	23,0	42,2	0,84700	PHE F180HTBFLG
200	B	-	-	150	-	-	138,0	114	M20	508	432,0	205	103	-	19	24,0	58,2	1,30100	PHE F200RSBFLG
200	F	4535	55	125	113,0	89	-	-	-	508	432,0	205	103	89	19	24,0	53,6	1,28100	PHE F200FTBFLG
200	H	4535	55	125	113,0	89	-	-	-	508	432,0	205	103	89	19	24,0	53,6	1,28100	PHE F200HTBFLG
220	B	-	-	160	-	-	154,5	127	M20	562	472,0	224	118	-	20	27,5	79,6	2,14200	PHE F220RSBFLG
220	F	5040	70	125	129,5	102	-	-	-	562	472,0	224	118	92	20	27,5	72,0	2,10400	PHE F220FTBFLG
220	H	5040	70	125	129,5	102	-	-	-	562	472,0	224	118	92	20	27,5	72,0	2,10400	PHE F220HTBFLG
250	B	-	-	190	-	-	161,5	132	M20	628	532,0	254	125	-	25	29,5	104,0	3,50500	PHE F250RSBFLG

All dimensions in mm unless otherwise specified

For coupling sizes 70, 80, 100 and 120 F flanges require a larger bush than H flanges.

* Is the clearance required to allow tightening/loosening of the clamping screws, and the taper bushing. Use of a shortened wrench will reduce this dimension.

+ The amount by which the clamping screws need to be withdrawn to release the tyre.

→ Mass and Inertia figures are for a single flange with midrange bore and include clamping ring, screws, washers and half tyre.



SKF Flex couplings

Reversible

- ▶ Belts
- ▶ Chains
- ▶ Couplings
- ▶ Bushings and Hubs
- ▶ Sprockets
- ▶ Pulleys
- ▶ Smart tools

Sizes 70-120

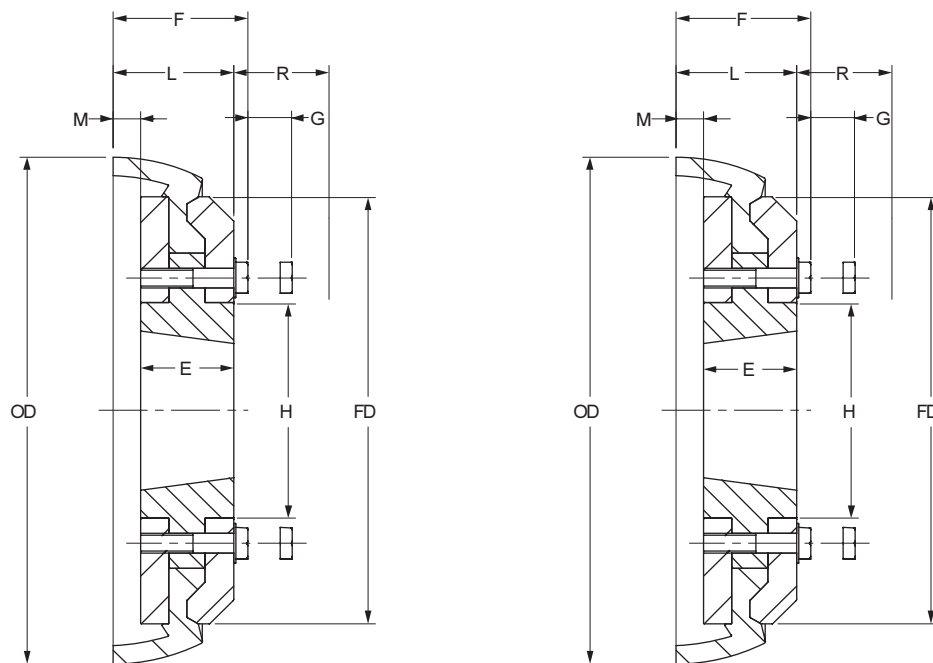

Dimensions of SKF Flex flanges type R

Size	Bush No.	Bore		Type R			Screw over Key	O.D	FD	H	F	G+	M	Mass →	Inertia →	Designation
		Min	Max	L	E	R*										
		mm	mm	mm	mm	mm		mm	mm	mm	mm	mm	mm	kg	kg/m ²	
F70	1610	14	42	37,0	25	42	M8	187	142	80	44,25	13	11,5	3,0	0,009	PHE F70RTBFLG
F80	2012	14	50	45,5	32	48	M8	211	165	98	52,75	16	12,5	4,6	0,017	PHE F80RTBFLG
F90	2517	16	60	58,5	45	48	M10	235	187	112	67,86	16	13,5	7,0	0,031	PHE F90RTBFLG
F100	2517	16	60	59,5	45	55	M10	254	214	125	68,86	16	13,5	9,4	0,054	PHE F100RTBFLG
F110	3020	25	75	64,5	51	55	M10	279	232	134	73,68	16	12,5	11,7	0,078	PHE F110RTBFLG
F120	3020	25	75	66,5	51	67	M12	314	262	140	77,18	16	14,5	15,9	0,130	PHE F120RTBFLG

All dimensions in mm unless otherwise specified

* The clearance required to allow tightening/loosening of the clamping screws.

+ The amount by which the clamping screws need to be withdrawn to release the tyre.

→ Mass and Inertia figures are for a single flange with midrange bore and include clamping ring, screws, washers and half tyre.



SKF Flex spacer couplings



Distance Between Shaft Ends (DBSE)

Spacer	Distance Between Shaft Ends (DBSE)		Coupling Size	Spacer Bush Size	Bore		Coupling Bush Size	Bore		Designation
	Nominal (min)	Max			Min	Max		Min	Max	
	mm	mm			mm	mm		mm	mm	
SM12	80	90	40	1210	11	32	1008	9	25	PHE SM12-80DBSE
SM12	100	110	40	1210	11	32	1008	9	25	PHE SM12-100DBSE
SM16	100	113	40	1615	14	42	1008	9	25	PHE SM16-100DBSE
SM16	140	150	40	1615	14	42	1008	9	25	PHE SM16-140DBSE
SM16	100	116	50	1615	14	42	1210	11	32	PHE SM16-100DBSE
SM16	140	156	50	1615	14	42	1210	11	32	PHE SM16-140DBSE
SM16	100	124	60	1615	14	42	1610	14	42	PHE SM16-100DBSE
SM16	140	164	60	1615	14	42	1610	14	42	PHE SM16-140DBSE
SM25	100	114	70	2517	16	60	2012	14	50	PHE SM25-100DBSE
SM25	140	154	70	2517	16	60	2012	14	50	PHE SM25-140DBSE
SM25	180	194	70	2517	16	60	2012	14	50	PHE SM25-180DBSE
SM25	100	117	80	2517	16	60	2517	16	60	PHE SM25-100DBSE
SM25	140	157	80	2517	16	60	2517	16	60	PHE SM25-140DBSE
SM25	180	197	80	2517	16	60	2517	16	60	PHE SM25-180DBSE
SM25	140	158	90	2517	16	60	2517	16	60	PHE SM25-140DBSE
SM25	180	198	90	2517	16	60	2517	16	60	PHE SM25-180DBSE
SM30	140	158	100	3020	25	75	3020	25	75	PHE SM30-140DBSE
SM30	180	198	100	3020	25	75	3020	25	75	PHE SM30-180DBSE
SM30	140	156	110	3020	25	75	3020	25	75	PHE SM30-140DBSE
SM30	180	196	110	3020	25	75	3020	25	75	PHE SM30-180DBSE
SM35	140	160	120	3525	35	100	3525	35	100	PHE SM35-140DBSE
SM35	180	200	120	3525	35	100	3525	35	100	PHE SM35-180DBSE
SM35	140	163	140	3525	35	100	3525	35	100	PHE SM35-140DBSE
SM35	180	203	140	3525	35	100	3525	35	100	PHE SM35-180DBSE

The SKF Flex coupling spacer is used to join two shaft ends that cannot be positioned close enough to just use a coupling alone. The spacer also allows removal of a shaft without needing to move either the driving or the driven machine. For example, this allows easy and fast replacement of impellers in pump applications.

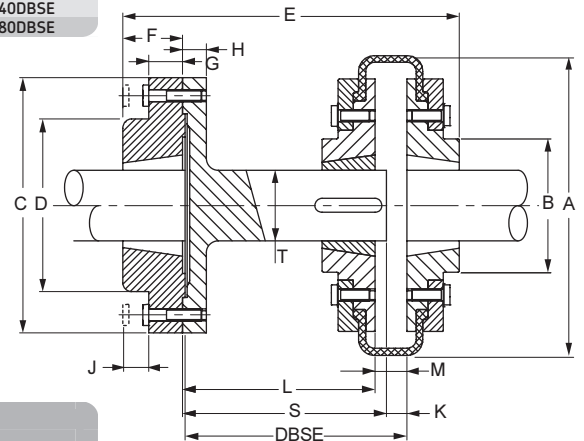

Spacer Coupling Dimensions

Spacer	Distance Between Shaft Ends (DBSE)		Coupling Size	Dimensions														
	Nominal (min)	Max		A	B	C	D	E	F	G	H	J	K	L	M	S	T	
SM12	80	90	40	104	82	118	83	134	25	14	15	14	6	65	22	77	25	
SM12	100	110	40	104	82	118	83	140	25	14	15	14	22	77	22	77	25	
SM16	100	113	40*	104	82	127	80	157	38	18	15	14	9	88	22	94	32	
SM16	140	150	40*	104	82	127	80	187	38	18	15	14	9	128	22	134	32	
SM16	100	116	50	133	79	127	80	160	38	18	15	14	9	85	25	94	32	
SM16	140	156	50	133	79	127	80	200	38	18	15	14	9	125	25	134	32	
SM16	100	124	60	165	103	127	80	161	38	18	15	14	9	78	33	94	32	
SM16	140	164	60	165	103	127	80	201	38	18	15	14	9	118	33	134	32	
SM25	100	114	70+	187	80	178	123	180	45	22	16	14	9	80	23	94	48	
SM25	140	154	70+	187	80	178	123	220	45	22	16	14	9	120	23	174	48	
SM25	180	194	70+	187	80	178	123	260	45	22	16	14	9	160	23	174	48	
SM25	100	117	80	211	95	178	123	193	45	22	16	14	9	78	25	94	48	
SM25	140	157	80	211	95	178	123	233	45	22	16	14	9	118	25	134	48	
SM25	180	197	80	211	95	178	123	273	45	22	16	14	9	158	25	174	48	
SM25	140	158	90	235	108	178	123	233	45	22	16	14	9	116	27	134	48	
SM25	180	198	90	235	108	178	123	273	45	22	16	14	9	156	27	174	48	
SM30	140	158	100	254	120	216	146	245	51	29	20	17	9	116	27	134	60	
SM30	180	198	100	254	120	216	146	285	51	29	20	17	9	156	27	174	60	
SM30	140	156	110	279	134	216	146	245	51	29	20	17	9	118	25	134	60	
SM30	180	196	110	279	134	216	146	285	51	29	20	17	9	158	25	174	60	
SM35	140	160	120	314	140	248	178	272	63	34	20	17	9	114	29	134	80	
SM35	180	200	120	314	140	248	178	312	63	34	20	17	9	154	29	174	80	
SM35	140	163	140	359	178	248	178	271	63	34	20	17	9	111	27	134	80	
SM35	180	203	140	359	178	248	178	312	63	34	20	17	9	151	27	174	80	

* F40 'B' Flange must be used to fit spacer shaft
+ 'F' Flange must be used to fit spacer shaft.



Gear couplings

Double engagement

- ▶ Belts
- ▶ Chains
- ▶ Couplings
- ▶ Bushings and Hubs
- ▶ Sprockets
- ▶ Pulleys
- ▶ Smart tools

Sizes 10 - 70

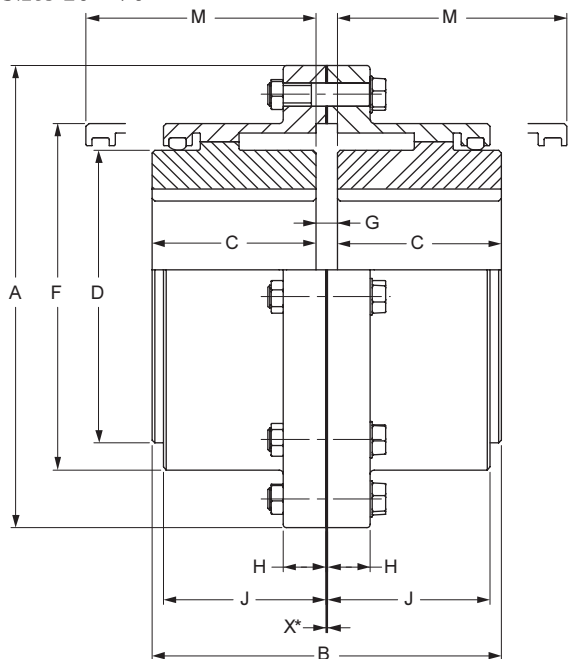

Sizes 80 - 120

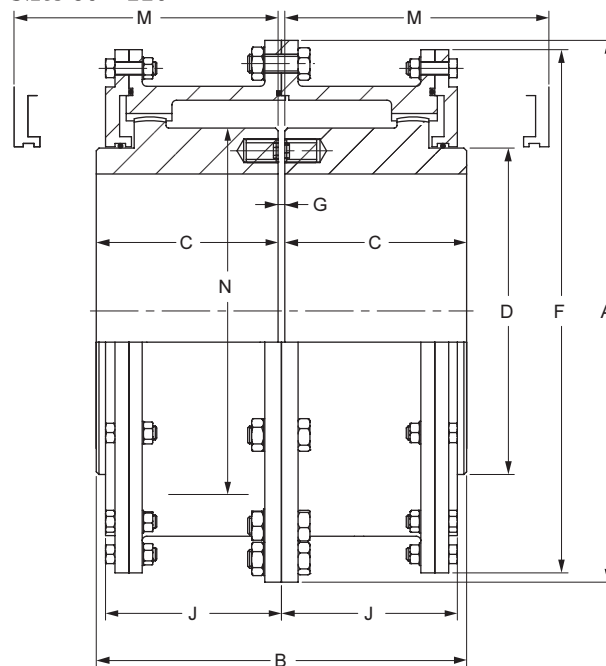

Designations

Size	Hub Designations	Cover Designations	Assembly Kit
10	PHE 10GCRSB	PHE 10GCCOVER	-
15	PHE 15GCRSB	PHE 15GCCOVER	-
20	PHE 20GCRSB	PHE 20GCCOVER	-
25	PHE 25GCRSB	PHE 25GCCOVER	-
30	PHE 30GCRSB	PHE 30GCCOVER	-
35	PHE 35GCRSB	PHE 35GCCOVER	-
40	PHE 40GCRSB	PHE 40GCCOVER	-
45	PHE 45GCRSB	PHE 45GCCOVER	-
50	PHE 50GCRSB	PHE 50GCCOVER	-
55	PHE 55GCRSB	PHE 55GCCOVER	-
60	PHE 60GCRSB	PHE 60GCCOVER	-
70	PHE 70GCRSB	PHE 70GCCOVER	-
80	PHE 80GCRSB	PHE 80GCMCOVER	PHE 80GCFCOVER
90	PHE 90GCRSB	PHE 90GCMCOVER	PHE 90GCFCOVER
100	PHE 100GCRSB	PHE 100GCMCOVER	PHE 100GCFCOVER
110	PHE 110GCRSB	PHE 110GCMCOVER	PHE 110GCFCOVER
120	PHE 120GCRSB	PHE 120GCMCOVER	PHE 120GCFCOVER

The assembly kit includes oil seals, gasket, bolts and lock-nuts.

A complete coupling consists of: 2 hubs, 2 covers and 1 assembly kit.

Coupling size 80 and above consists of: 2 hubs, 1 male cover, 1 female cover and 1 assembly kit.

Physical characteristics

Size	KW per 100 rpm	Rated torque	Max speed	Bore diameter		Dimensions (mm)								Coupling weight kg	Lubricant weight kg
		Nm	rpm	Min	Max	A	B	C	D	F	J	G	M		
10	11,9	1139	8000	13	50	116	89	43	69	84	39	3	51	5	0,04
15	24,6	2350	6500	20	65	152	101	49	86	105	48	3	61	9	0,07
20	44,7	4270	5600	26	78	178	127	62	105	126	59	3	76	16	0,12
25	78,3	7474	5000	32	98	213	159	77	131	155	72	5	91	29	0,23
30	127,0	12100	4400	39	111	240	187	91	152	180	84	5	107	43	0,36
35	194,0	18500	3900	51	134	279	218	106	178	211	98	6	130	68	0,54
40	321,0	30609	3600	64	160	318	248	121	210	245	111	6	145	97	0,91
45	440,0	42000	3200	77	183	346	278	135	235	274	123	8	165	136	1,04
50	593,0	56600	2900	89	200	389	314	153	254	306	141	8	183	190	1,77
55	775,0	74030	2650	102	220	425	344	168	279	334	158	8	203	249	2,22
60	947,0	90400	2450	115	244	457	384	188	305	366	169	8	229	306	3,18
70	1420,0	135000	2150	127	289	527	452	221	343	425	196	10	267	485	4,35
80	1780,0	170000	1750	102	266	591	508	249	356	572	243	10	300	703	9,53
90	2360,0	226000	1550	115	290	660	565	276	394	641	265	13	327	984	12,25
100	3250,0	310000	1450	127	320	711	623	305	445	699	294	13	356	1302	14,97
110	4320,0	413000	1330	140	373	775	679	333	495	749	322	13	384	1678	17,69
120	5810,0	555000	1200	153	400	838	719	353	546	826	341	13	403	2114	20,87

X* represents space taken by the gasket



Grid couplings

Horizontal split cover



Designations

Size	Hub Designations	Grid Designations	Cover Designations
1020	PHE 1020TGRSB	PHE 1020TGGRID	PHE 1020TGHCOVER
1030	PHE 1030TGRSB	PHE 1030TGGRID	PHE 1030TGHCOVER
1040	PHE 1040TGRSB	PHE 1040TGGRID	PHE 1040TGHCOVER
1050	PHE 1050TGRSB	PHE 1050TGGRID	PHE 1050TGHCOVER
1060	PHE 1060TGRSB	PHE 1060TGGRID	PHE 1060TGHCOVER
1070	PHE 1070TGRSB	PHE 1070TGGRID	PHE 1070TGHCOVER
1080	PHE 1080TGRSB	PHE 1080TGGRID	PHE 1080TGHCOVER
1090	PHE 1090TGRSB	PHE 1090TGGRID	PHE 1090TGHCOVER
1100	PHE 1100TGRSB	PHE 1100TGGRID	PHE 1100TGHCOVER
1110	PHE 1110TGRSB	PHE 1110TGGRID	PHE 1110TGHCOVER
1120	PHE 1120TGRSB	PHE 1120TGGRID	PHE 1120TGHCOVER
1130	PHE 1130TGRSB	PHE 1130TGGRID	PHE 1130TGHCOVER
1140	PHE 1140TGRSB	PHE 1140TGGRID	PHE 1140TGHCOVER
1150	PHE 1150TGRSB	PHE 1150TGGRID	PHE 1150TGHCOVER
1160	PHE 1160TGRSB	PHE 1160TGGRID	PHE 1160TGHCOVER
1170	PHE 1170TGRSB	PHE 1170TGGRID	PHE 1170TGHCOVER
1180	PHE 1180TGRSB	PHE 1180TGGRID	PHE 1180TGHCOVER
1190	PHE 1190TGRSB	PHE 1190TGGRID	PHE 1190TGHCOVER
1200	PHE 1200TGRSB	PHE 1200TGGRID	PHE 1200TGHCOVER

A complete coupling consists of 2 hubs, 1 grid and 1 cover.

To order a spare kit assembly use suffix 'HKIT' after the coupling type, e.g. PHE 1020TGHKIT.

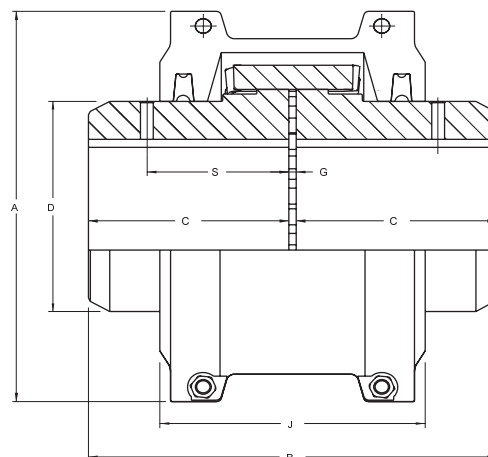

Physical characteristics

Size	KW per 100 rpm	Rated torque Nm	Max speed rpm	Bore diameter		Dimensions (mm)						G (mm)			Coupling weight kg	Lubricant weight kg
				Min	Max	A	B	C	D	J	S	Min	Normal	Max		
1020	0,51	52	4500	12	30	101	98,0	47,5	39,7	66	39	1,5	3,0	4,5	1,9	0,03
1030	1,44	149	4500	12	36	111	98,0	47,5	49,2	68	39	1,5	3,0	4,5	2,6	0,04
1040	2,40	249	4500	12	44	117	104,6	50,8	57,1	70	40	1,5	3,0	4,5	3,4	0,05
1050	4,20	435	4500	12	50	138	123,6	60,3	66,7	79	45	1,5	3,0	4,5	5,4	0,05
1060	6,60	684	4350	19	57	150	130,0	63,5	76,2	92	52	1,5	3,0	4,5	7,3	0,09
1070	9,69	994	4125	19	65	162	155,4	76,2	87,3	95	54	1,5	3,0	4,5	10,0	0,12
1080	20,13	2050	3600	27	79	194	180,8	88,9	104,8	116	65	1,5	3,0	6,0	18,0	0,17
1090	35,79	3730	3600	27	95	213	199,8	98,4	123,8	122	72	1,5	3,0	6,0	25,0	0,25
1100	60,40	6280	2440	41	107	250	245,7	120,6	142,0	155	-	1,5	4,5	9,5	42,0	0,43
1110	90,23	9320	2250	41	117	270	258,5	127,0	160,3	161	-	1,5	4,5	9,5	54,0	0,51
1120	131,99	13700	2025	60	136	308	304,4	149,2	179,4	191	-	1,5	6,0	12,5	81,0	0,73
1130	191,64	19900	1800	66	165	346	329,8	161,9	217,5	195	-	1,5	6,0	12,5	121,0	0,91
1140	275,91	28600	1650	66	184	384	371,6	182,8	254,0	201	-	1,5	6,0	12,5	178,0	1,13
1150	384,04	39800	1500	108	203	453	371,8	182,9	269,2	271	-	1,5	6,0	12,5	234,0	1,95
1160	539,89	55900	1350	120	228	501	402,2	198,1	304,8	279	-	1,5	6,0	12,5	317,0	2,81
1170	719,60	74600	1225	133	279	566	437,8	215,9	355,6	304	-	1,5	6,0	12,5	448,0	3,49
1180	997,75	103000	1100	152	311	623	483,6	238,8	393,7	321	-	1,5	6,0	12,5	619,0	3,76
1190	1319,89	137000	1050	152	339	675	524,2	259,1	436,9	325	-	1,5	6,0	12,5	776,0	4,40
1200	1799,37	186000	900	177	361	757	564,8	279,4	497,8	356	-	1,5	6,0	12,5	1057,0	5,62



Grid couplings

Vertical split cover

- ▶ Belts
- ▶ Chains
- ▶ Couplings
- ▶ Bushings and Hubs
- ▶ Sprockets
- ▶ Pulleys
- ▶ Smart tools

Designations

Size	Hub Designations	Grid Designations	Cover Designations
1020	PHE 1020GRSB	PHE 1020GGRID	PHE 1020GVCOVER
1030	PHE 1030GRSB	PHE 1030GGRID	PHE 1030GVCOVER
1040	PHE 1040GRSB	PHE 1040GGRID	PHE 1040GVCOVER
1050	PHE 1050GRSB	PHE 1050GGRID	PHE 1050GVCOVER
1060	PHE 1060GRSB	PHE 1060GGRID	PHE 1060GVCOVER
1070	PHE 1070GRSB	PHE 1070GGRID	PHE 1070GVCOVER
1080	PHE 1080GRSB	PHE 1080GGRID	PHE 1080GVCOVER
1090	PHE 1090GRSB	PHE 1090GGRID	PHE 1090GVCOVER
1100	PHE 1100GRSB	PHE 1100GGRID	PHE 1100GVCOVER
1110	PHE 1110GRSB	PHE 1110GGRID	PHE 1110GVCOVER
1120	PHE 1120GRSB	PHE 1120GGRID	PHE 1120GVCOVER
1130	PHE 1130GRSB	PHE 1130GGRID	PHE 1130GVCOVER
1140	PHE 1140GRSB	PHE 1140GGRID	PHE 1140GVCOVER
1150	PHE 1150GRSB	PHE 1150GGRID	PHE 1150GVCOVER
1160	PHE 1160GRSB	PHE 1160GGRID	PHE 1160GVCOVER
1170	PHE 1170GRSB	PHE 1170GGRID	PHE 1170GVCOVER
1180	PHE 1180GRSB	PHE 1180GGRID	PHE 1180GVCOVER
1190	PHE 1190GRSB	PHE 1190GGRID	PHE 1190GVCOVER
1200	PHE 1200GRSB	PHE 1200GGRID	PHE 1200GVCOVER

A complete coupling consists of 2 hubs, 1 grid and 1 cover.
To order a spare kit assembly use suffix 'VKIT' after the coupling type, e.g. PHE 1020GVKIT

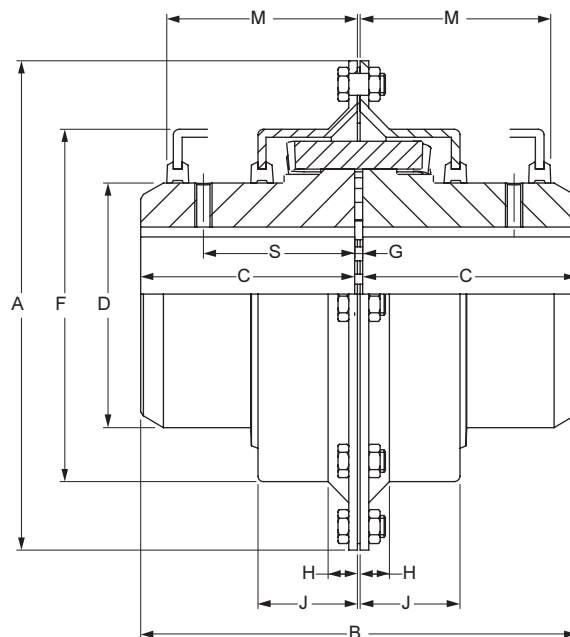

Physical characteristics

Size	KW per 100 rpm	Rated Torque	Max Speed	Bore Diameter		Dimensions (mm)										G (mm)			Coupling weight	Lubricant weight
				Min	Max	A	B	C	D	J	F	H	M	S	Min	Normal	Max			
1020	0,51	52	6000	12	30	111	98,0	47,5	39,7	24	64	10	48	39	1,5	3,0	4,5	2,0	0,03	
1030	1,44	149	6000	12	36	121	98,0	47,5	49,2	25	73	10	48	39	1,5	3,0	4,5	2,6	0,04	
1040	2,40	249	6000	12	44	128	104,6	50,8	57,1	26	83	10	51	40	1,5	3,0	4,5	3,4	0,05	
1050	4,20	435	6000	12	50	148	123,6	60,3	66,7	31	99	12	60	45	1,5	3,0	4,5	5,4	0,05	
1060	6,60	684	6000	19	57	162	130,0	63,5	76,2	32	111	13	64	52	1,5	3,0	4,5	7,3	0,09	
1070	9,69	994	5500	19	65	173	155,4	76,2	87,3	34	124	13	67	54	1,5	3,0	4,5	10,0	0,12	
1080	20,13	2050	4750	27	79	200	180,8	88,9	104,8	44	149	13	89	65	1,5	3,0	6,0	18,0	0,17	
1090	35,79	3730	4000	27	95	232	199,8	98,4	123,8	48	168	13	95	72	1,5	3,0	6,0	25,0	0,25	
1100	60,40	6280	3250	41	107	267	245,7	120,6	142,0	60	197	16	121	-	1,5	4,5	9,5	42,0	0,43	
1110	90,23	9320	3000	41	117	286	258,5	127,0	160,3	64	216	16	124	-	1,5	4,5	9,5	54,0	0,51	
1120	131,99	13700	2700	60	136	319	304,4	149,2	179,4	73	244	17	143	-	1,5	6,0	12,5	81,0	0,73	
1130	191,64	19900	2400	66	165	378	329,8	161,9	217,5	75	282	21	146	-	1,5	6,0	12,5	122,0	0,91	
1140	275,91	28600	2200	66	184	416	371,6	182,8	254,0	78	321	21	155	-	1,5	6,0	12,5	180,0	1,13	
1150	384,04	39800	2000	108	203	476	371,8	182,9	269,2	107	374	19	203	-	1,5	6,0	12,5	230,0	1,95	
1160	539,89	55900	1750	120	228	533	402,2	198,1	304,8	114	424	30	216	-	1,5	6,0	12,5	321,0	2,81	
1170	719,60	74600	1600	133	279	584	437,8	215,9	355,6	119	474	30	226	-	1,5	6,0	12,5	448,0	3,49	
1180	997,75	103000	1400	152	311	630	483,6	238,8	393,7	130	-	-	-	-	1,5	6,0	12,5	591,0	3,76	
1190	1319,89	137000	1300	152	339	685	524,2	259,1	436,9	135	-	-	-	-	1,5	6,0	12,5	761,0	4,40	
1200	1799,37	186000	1100	177	361	737	564,8	279,4	497,8	145	-	-	-	-	1,5	6,0	12,5	1021,0	5,62	



Chain couplings



Selection

Chain couplings are able to transmit greater torques than the shafts that carry them making them ideal for high torque applications. Available with pilot bore, finished bore or taper bush (face or hub), flanges are linked together with duplex roller chain accommodating misalignments up to 2°.

To ensure maximum service life and reliability, particularly for high speed applications, it is recommended that all chain couplings are fitted with a cover and are properly lubricated.

Where the chain coupling is subject to reversing operations, shock or pulsating loads, or other severe operating conditions, a coupling one size larger should be selected.

Taper Bushed Couplings Assembly Configurations

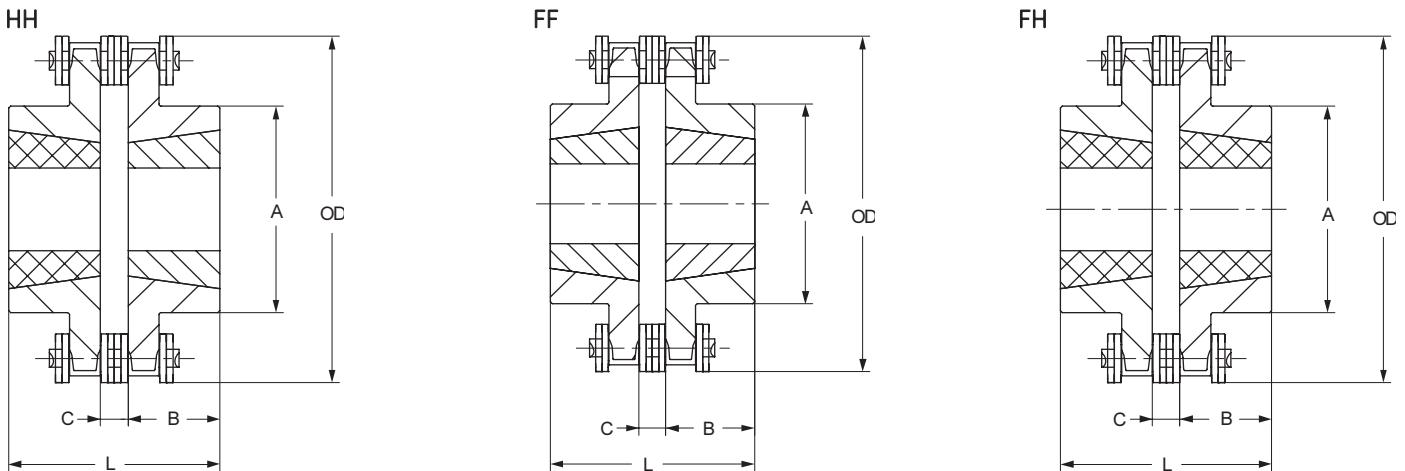

Bored to Size Couplings

Coupling Size	Bore		A	B	C	L	OD	Weight	Recommended Maximum RPM	Nominal Torque	Chain Weight
	Min (Pilot)	Max									
	mm	mm	mm	mm	mm	mm	mm	kg		Nm	kg
IS0816	15,9	23,8	50,0	28,96	7,1	65,0	77,0	0,45	5000	160	0,23
IS1016	15,9	42,9	63,5	36,88	9,5	83,3	96,0	1,00	4000	250	0,54
IS1018	19,1	50,8	75,4	43,26	9,5	87,1	106,4	1,59	3600	250	0,59
IS1218	25,4	61,9	88,9	47,60	11,1	106,3	127,0	2,27	3000	630	1,00
IS1220	28,6	69,9	98,4	50,80	11,1	112,7	139,7	2,95	2500	630	1,18
IS1222	28,6	76,2	114,3	54,00	11,1	119,1	151,2	4,31	2500	630	1,23
IS1618	28,6	79,4	115,9	60,70	14,7	136,1	169,1	4,99	2000	1600	2,40
IS1620	38,1	90,5	136,5	66,10	14,7	146,9	185,3	7,40	2000	1600	2,68
IS2018	38,1	98,4	144,5	70,90	18,3	160,1	211,5	9,21	1800	2500	4,45
IS2020	38,1	117,5	170,7	79,80	18,3	177,9	231,8	14,43	1800	2500	4,95
IS2418	50,8	119,1	171,5	88,30	21,8	198,4	254,0	16,70	1500	4000	7,85
IS2422	50,8	155,6	222,3	102,10	21,8	226,0	302,0	31,76	1200	4000	9,62

Taper Bushed Couplings Type "FTB" and "HTB"

Coupling Number	Bushing Data			A	B	C	L	OD	Weight
	No.	Min Bore							
		mm	mm						
IS0816	1108	12,7	28,6	50,0	22,2	7,1	51,6	77,0	0,41
IS1018	1610	12,7	41,3	75,4	25,4	9,5	60,3	106,4	0,50
IS1220	2012	12,7	50,8	98,4	31,8	11,1	74,6	139,7	1,23
IS1620	3020	23,8	76,2	136,5	50,0	14,7	116,3	185,3	2,77
IS2020	3535	30,2	88,9	170,7	88,9	18,3	196,1	231,8	8,62



Chain couplings

- ▶ Belts
- ▶ Chains
- ▶ Couplings
- ▶ Bushings and Hubs
- ▶ Sprockets
- ▶ Pulleys
- ▶ Smart tools

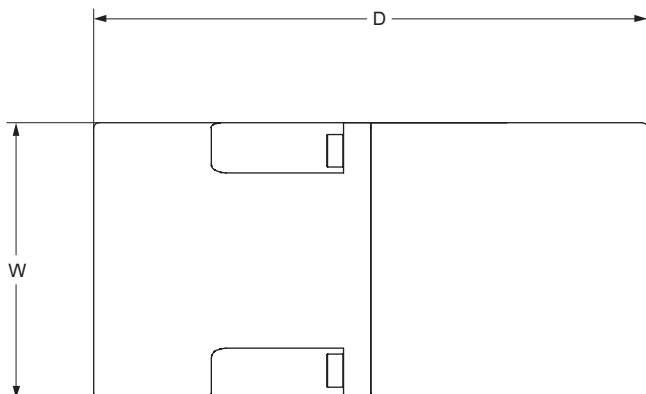

Coupling Covers

Cover Size	Aluminium		Plastic		Weight kg
	D	W	D	W	
	mm	mm	mm	mm	
IS0816**	101,6	50,8	101,6	58,7	0,42
IS1016**	130,2	60,3	130,2	66,7	0,59
IS1018**	130,2	60,3	130,2	66,7	0,59
IS1218**	161,9	74,6	161,9	77,8	1,11
IS1220**	161,9	74,6	161,9	77,8	1,11
IS1222*	208,0	101,6	208,0	101,6	2,21
IS1618	208,0	101,6	208,0	101,6	2,21
IS1620	208,0	101,6	208,0	101,6	2,21
IS2018	238,1	150,8	238,1	150,8	3,97
IS2020	257,2	133,4	257,2	133,4	5,74
IS2418	288,9	187,3	288,9	187,3	7,47
IS2422	336,6	201,6	336,6	201,6	8,85

* Use IS1618 cover – special seals available

** Will be supplied in plastic unless otherwise specified

Designations

Size	Hub				Chain	Covers
	Plain Bore	FTB	HTB	Bored to Size*		
IS0816	PHE IS0816RSB	PHE IS0816FTB	PHE IS0816HTB	PHE IS0816X...	PHE IS0816CHN	PHE IS0816COVER
IS1016	PHE IS1016RSB	–	–	PHE IS1016X...	PHE IS1016CHN	PHE IS1016COVER
IS1018	PHE IS1018RSB	PHE IS1018FTB	PHE IS1018HTB	PHE IS1018X...	PHE IS1018CHN	PHE IS1018COVER
IS1218	PHE IS1218RSB	–	–	PHE IS1218X...	PHE IS1218CHN	PHE IS1218COVER
IS1220	PHE IS1220RSB	PHE IS1220FTB	PHE IS1220HTB	PHE IS1220X...	PHE IS1220CHN	PHE IS1220COVER
IS1222	PHE IS1222RSB	–	–	PHE IS1222X...	PHE IS1222CHN	PHE IS1222COVER
IS1618	PHE IS1618RSB	–	–	PHE IS1618X...	PHE IS1618CHN	PHE IS1618COVER
IS1620	PHE IS1620RSB	PHE IS1620FTB	PHE IS1620HTB	PHE IS1620X...	PHE IS1620CHN	PHE IS1620COVER
IS2018	PHE IS2018RSB	–	–	PHE IS2018X...	PHE IS2018CHN	PHE IS2018COVER
IS2020	PHE IS2020RSB	PHE IS2020FTB	PHE IS2020HTB	PHE IS2020X...	PHE IS2020CHN	PHE IS2020COVER
IS2418	PHE IS2418RSB	–	–	PHE IS2418X...	PHE IS2418CHN	PHE IS2418COVER
IS2422	PHE IS2422RSB	–	–	PHE IS2422X...	PHE IS2422CHN	PHE IS2422COVER

* To complete bored to size designation, add bore size. For example: PHE IS1016X22MM designates hub size IS1016 with a 22mm bore



Rigid couplings

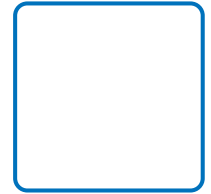

Taper bush Rigid couplings provide a convenient method of rigidly connecting ends of shafts. Taper bushes permit easier and quicker fixing to the shafts with the firmness of a shrunk on fit. These couplings have a fully machined male and female flange. The male flange can have the bushing fitted from the Hub side A (MH) or from the Flange side B (H); the female flange (F) always has the bushing fitted from the Flange side B. This gives two possible coupling assemblies as AB and BB. When connecting horizontal shafts, the most convenient assembly should be chosen. For connecting vertical shafts use assembly BB only.

Selection

For all application using standard mild steel shafting it is sufficiently accurate to select the coupling by consideration of bore size alone. For all other applications consult SKF.

Coupling Assembly AB

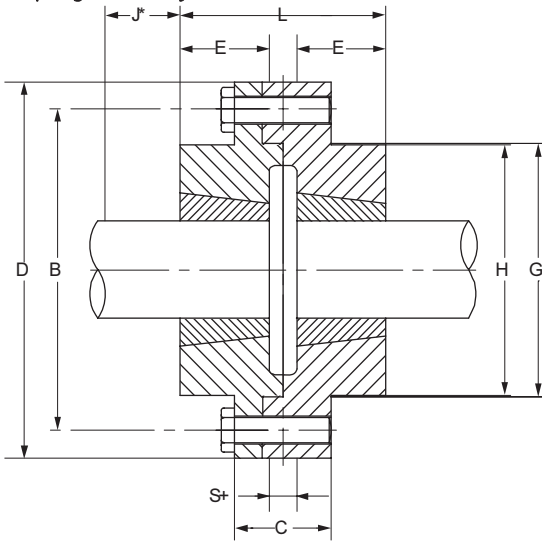

Coupling Assembly BB

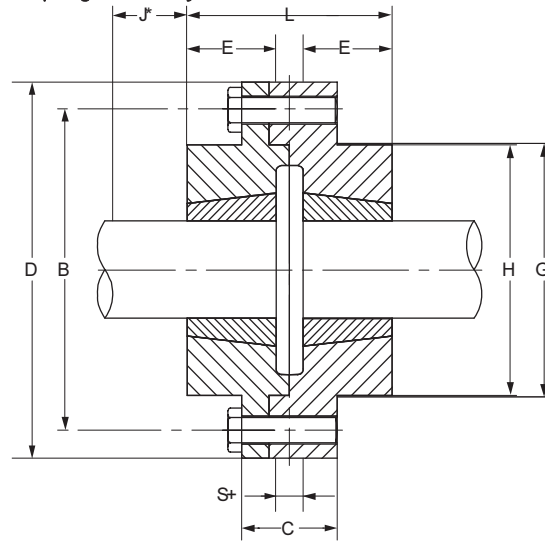

Taper Bushed Couplings

Coupling Size	Bushing Data		Dimensions									Weight** (kg)
	Bushing No	Max Bore (mm)	D	C	E	H	G Nominal	B Nominal	S+	J*	L	
R12	1210	32	118	35	25	83	76	102	7	38	57	3,5
R16	1615	42	127	43	38	80	89	105	7	38	83	4,5
R25	2517	60	178	51	45	123	127	149	7	48	97	11,0
R30	3020	75	216	65	51	146	152	181	7	54	109	20,0
R35	3525	100	248	75	65	178	178	213	7	67	137	34,0
R40	4030	110	298	76	76	210	216	257	7	79	159	59,0
R45	4535	125	330	86	89	230	241	246	7	89	185	80,0
R50	5040	125	362	92	102	266	267	314	7	92	211	135,0

All Dimensions in mm

J* is the wrench clearance to allow for tightening and loosening the bush on the shaft.

The use of a shortened wrench will permit this dimension to be reduced

S+ is the distance between shaft ends

** Weight given are for couplings with midrange Taper bushes.

Designations

Size	Coupling Assembly AB		Coupling Assembly BB	
	Male	Female	Male	Female
R12	PHE R12MHTB	PHE R12FTB	PHE R12HTB	PHE R12FTB
R16	PHE R16MHTB	PHE R16FTB	PHE R16HTB	PHE R16FTB
R25	PHE R25MHTB	PHE R25FTB	PHE R25HTB	PHE R25FTB
R30	PHE R30MHTB	PHE R30FTB	PHE R30HTB	PHE R30FTB
R35	PHE R35MHTB	PHE R35FTB	PHE R35HTB	PHE R35FTB
R40	PHE R40MHTB	PHE R40FTB	PHE R40HTB	PHE R40FTB
R45	PHE R45MHTB	PHE R45FTB	PHE R45HTB	PHE R45FTB
R50	PHE R50MHTB	PHE R50FTB	PHE R50HTB	PHE R50FTB

A complete coupling consists of one male and one female flange

Example: Coupling Assembly AB PHE R12MHTB and PHE R12FTB

Coupling Assembly BB PHE R12HTB and PHE R12FTB



FRC couplings

Selection

- ▶ Belts
- ▶ Chains
- ▶ Couplings
- ▶ Bushings and Hubs
- ▶ Sprockets
- ▶ Pulleys
- ▶ Smart tools

With a higher load capacity than Jaw couplings and maintenance free operation FRC couplings are designed as a general purpose coupling cushioning moderate shock loads, dampening small vibrations and accommodating incidental misalignments. Phosphate coated for improved corrosion resistance and available with fire-resistant and anti-static elements (F.R.A.S.) FRC couplings are offered in pilot bore, finished bore and taper bushed (face or hub), facilitating quick and simple installation. Fully machined outside diameters allow alignment by simple straight edge methods. Shaft connection is "fail safe" due to interlocking jaw design.

Selection

Service Factor

- Determine the required service factor from the table below.

Design Power

- Multiply the normal running power by the service factor. This gives the design power for coupling selection.

Coupling Size

- Using the Power Ratings table read across from the appropriate speed until a power greater than the design power is found. The required FRC coupling is given at the head of the column.

Bore Size

- Using the dimensions table check that chosen flanges can accommodate both driving and driven shafts.

Example

A FRC coupling is required to transmit 15 kW from an Electric motor running at 500 rev/min to a rotary pump for 15 hours per day. The motor shaft is 25 mm diameter and the pump shaft is 20 mm diameter.

1. Service factor

The appropriate service factor is 1,8.

2. Design Power

Design power = 15 x 1,8 = 27 kW

3. Coupling size

By reading across from the 500 rev/min in the power ratings table the first power figure to exceed the required 27 kW in step(2) is 31,41 kW. The size of the coupling is 150 FRC.

4. Bore Size

By referring to the dimensions table it can be seen that both shaft diameters fall within the bore range available.

Service Factors

		Type of driving unit: Electric motors and steam Turbines			Type of driving unit: Internal combustion engines, steam engines and water turbines		
		Duty hours per day			Duty hours per day		
		Up to 10	10 to 16	Over 16	Up to 10	10 to 16	Over 16
Light	Agitators/Mixers [liquids], belt conveyors [uniform loading], blowers and exhausters, centrifugal pumps and compressors, fans [below 7,5 kW]	1	1,1	1,2	1,3	1,4	1,6
Medium	Agitators/Mixers [non-liquid], Belt and chain conveyors [variable loading], fans (over 7,5 kW), generators, line shafts, machine tools, rotary pumps and compressors (other than centrifugal) Machinery for food processing, laundries and printing industries	1,6	1,8	2	2	2,2	2,5
Heavy	Heavy duty conveyors [bucket, drag/shovel, screw], hammer mills, presses, punches, shears, piston pumps and compressors Machinery for brick, textile, paper, saw mill industries	2	2,2	2,3	2,5	2,6	2,8
Very Heavy	Crushers [gyratory, jaw, roll], Heavy duty mills [ball, rod, tube], Hoists	2,5	2,8	3,1	3,2	3,6	4

It is recommended that keys are fitted for applications where load fluctuation is expected



FRC couplings

Selection



Power Ratings (kW)

Speed	Coupling Size							
	70	90	110	130	150	180	230	280
RPM								
50	0,16	0,42	0,84	1,65	3,14	4,97	10,47	16,49
100	0,33	0,84	1,68	3,30	6,28	9,95	20,94	32,98
200	0,66	1,68	3,35	6,60	12,57	19,90	41,88	65,97
300	0,99	2,51	5,03	9,90	18,85	29,84	62,83	98,95
400	1,32	3,35	6,70	13,19	25,13	39,79	83,77	131,94
500	1,65	4,19	8,38	16,49	31,41	49,74	104,71	164,92
600	1,98	5,03	10,05	19,79	37,70	59,69	125,65	197,91
700	2,31	5,86	11,73	23,09	43,98	69,63	146,60	230,89
720	2,37	6,03	12,06	23,75	45,24	71,62	150,79	237,49
800	2,64	6,70	13,40	26,39	50,26	79,58	167,54	263,87
900	2,97	7,54	15,08	29,69	56,54	89,53	188,48	296,86
960	3,17	8,04	16,08	31,66	60,31	95,50	201,05	316,65
1000	3,30	8,38	16,75	32,98	62,83	99,48	209,42	329,84
1200	3,96	10,05	20,10	39,58	75,39	119,37	251,31	395,81
1400	4,62	11,73	23,46	46,18	87,96	139,27	293,19	461,78
1440	4,75	12,06	24,13	47,50	90,47	143,25	301,57	474,97
1600	5,28	13,40	26,81	52,77	100,52	159,16	335,08	527,75
1800	5,94	15,08	30,16	59,37	113,09	179,06	376,96	593,72
2000	6,60	16,75	33,51	65,97	125,65	198,95	418,85	659,69
2200	7,26	18,43	36,86	72,57	138,22	218,85	460,73	725,65
2400	7,92	20,10	40,21	79,16	150,79	238,74	502,62	–
2600	8,58	21,78	43,56	85,76	163,35	258,64	544,50	–
2800	9,24	23,46	46,91	92,36	175,92	278,53	–	–
2880	9,50	24,13	48,25	94,99	180,94	286,49	–	–
3000	9,90	25,13	50,26	98,95	188,48	298,43	–	–
3600	11,87	30,16	60,31	118,74	226,18	–	–	–
Nominal Torque	31	80	160	315	600	950	2000	3150
Max Torque	72	180	360	720	1500	2350	5000	7200

Maximum torque figures should be treated as a short duration overload ratings occurring in circumstances such as direct-on-line starting.

For speeds not shown calculate the nominal torque for the design application using the formula below and select coupling according to nominal torque ratings.

$$\text{Nominal Torque (Nm)} = \frac{\text{Design power (kW)} \times 30000}{\text{RPM} \times \pi}$$

Designations

Size	Type F	Type H	Type B Pilot bored	Standard Element -40 °C / +100 °C	FRAS Element -20 °C / +80 °C
70	PHE FRC70FTB	PHE FRC70HTB	PHE FRC70RSB	PHE FRC70NR	PHE FRC70FR
90	PHE FRC90FTB	PHE FRC90HTB	PHE FRC90RSB	PHE FRC90NR	PHE FRC90FR
110	PHE FRC110FTB	PHE FRC110HTB	PHE FRC110RSB	PHE FRC110NR	PHE FRC110FR
130	PHE FRC130FTB	PHE FRC130HTB	PHE FRC130RSB	PHE FRC130NR	PHE FRC130FR
150	PHE FRC150FTB	PHE FRC150HTB	PHE FRC150RSB	PHE FRC150NR	PHE FRC150FR
180	PHE FRC180FTB	PHE FRC180HTB	PHE FRC180RSB	PHE FRC180NR	PHE FRC180FR
230	PHE FRC230FTB	PHE FRC230HTB	PHE FRC230RSB	PHE FRC230NR	PHE FRC230FR
280	PHE FRC280FTB	PHE FRC280HTB	PHE FRC280RSB	PHE FRC280NR	PHE FRC280FR

A complete coupling consist of 2 hubs and 1 element.



FRC couplings

Selection

- ▶ Belts
- ▶ Chains
- ▶ Couplings
- ▶ Bushings and Hubs
- ▶ Sprockets
- ▶ Pulleys
- ▶ Smart tools

Type B

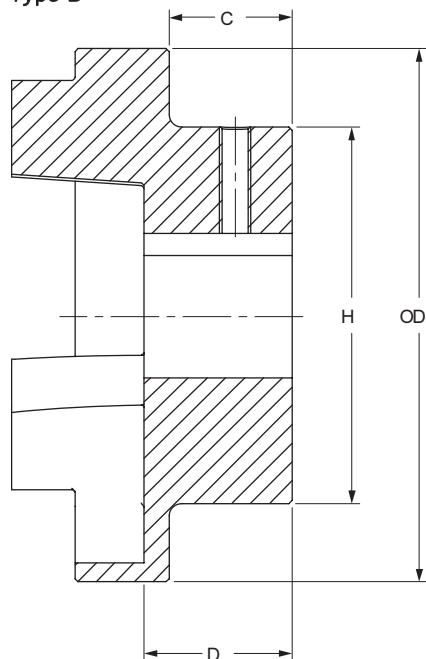

Type F

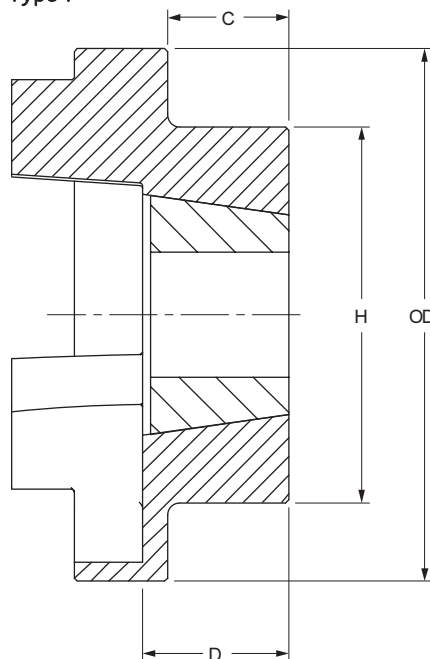

Type H

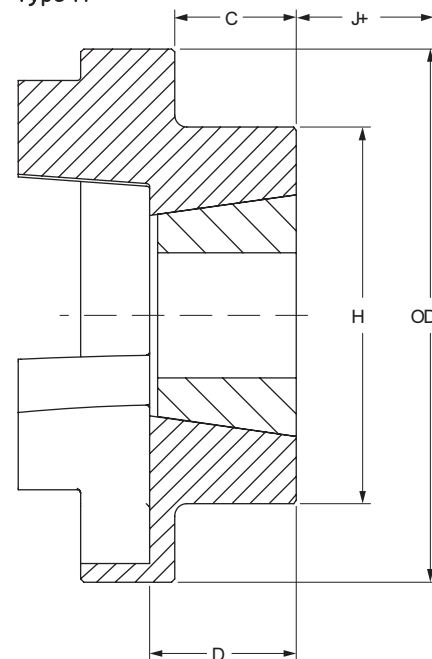

Dimensions

Size	Common Dimensions		Type F&H						Type B				
	OD	H	Bush size	Bore Min	Bore Max	C	D	J+	Bore Diametar Max	Bore Diametar Pilot	Key Screw	C	D
				mm	mm				mm	mm			
70	69	60	1008	9	25	20,0	23,5	29	32	10	M6	20	25,8
90	85	70	1108	9	28	19,5	23,5	29	38	10	M6	26	30,0
110	112	100	1610	14	42	18,5	26,5	38	55	10	M10	37	45,3
130	130	105	1610	14	42	18,0	26,5	38	60	20	M10	39	47,5
150	150	115	2012	14	50	23,5	33,5	42	70	28	M10	46	60,0
180	180	125	2517	16	60	34,5	46,5	48	80	28	M10	58	70,0
230	225	155	3020	25	75	39,5	52,5	55	100	45	M12	77	90,0
280	275	206	3525	35	100	51,0	66,5	67	115	55	M16	90	105,5

+ The clearance required for tightening/loosening the bush on the shaft

Assembled Dimensions and Characteristics

Size	Assembled Length Comprising Flange Types			Mass	Inertia	Torsional Stiffness	Misalignment			Nominal Torque	Max Torque
	FF,FH,HH	FB,HB	BB				Angular	Parallel	Axial		
	mm	mm	mm				°	mm	mm		
70	65,0	65,0	65,0	1,00	0,00	-	1	0,3	0,2	31,5	72
90	69,5	76,0	82,5	1,17	0,00	-	1	0,3	0,5	80,0	180
110	82,0	100,5	119,0	5,00	0,00	65	1	0,3	0,6	160,0	360
130	89,0	110,0	131,0	5,46	0,01	130	1	0,4	0,8	315,0	720
150	107,0	129,5	152,0	7,11	0,02	175	1	0,4	0,9	600,0	1500
180	142,0	165,5	189,0	16,60	0,04	229	1	0,4	1,1	950,0	2350
230	164,5	202,0	239,5	26,00	0,12	587	1	0,5	1,3	2000,0	5000
280	207,5	246,5	285,5	50,00	0,45	1025	1	0,5	1,7	3150,0	7200

Mass is for an FF, FH or HH coupling with mid range taper bushes.



Jaw couplings

Selection



Jaw couplings provide a cost effective solution for standard power applications, cushioning moderate shock loads and dampening small vibrations.

Maintenance free and easy to install jaw couplings are available with a "snap wrap" element allowing element replacement in situ.

Urethane and Hytrel elements have a greater power rating than that of Nitrile and are recommended for applications where it is required to transmit high power or minimise coupling size.

Selection

Service Factor

- Determine the required service factor from the table below.

Design Power

- Multiply the normal running power by the service factor. This gives the design power for selecting a coupling with a Nitrile element.

Alternative Elements

- To allow coupling selection to take place on one power rating table (Nitrile) an element correction is required to give a new reference design power. This is found by dividing the design power calculated for a Nitrile element by the alternative element power factor.

Coupling Size

- Using the Power Ratings table read across from the appropriate speed until a power greater than the design power is found. The required Jaw coupling is given at the head of the column.

Bore Size

- Using the dimensions table check that chosen flanges can accommodate both driving and driven shafts.

Example

A Jaw coupling is required to transmit 4 kW from an Electric motor running at 300 rev/min to a centrifugal fan for 12 hours per day. The motor shaft is 20 mm diameter and the pump shaft is 18 mm diameter.

1. Service factor

The appropriate service factor is 1,1.

2. Design Power

Design Power = $4 \times 1,1 = 4,4$ kW

3. Coupling size

By reading across from the 300 rev/min in the power ratings table the first power figure to exceed the required 4,4 kW in step(2) is 4,7 kW. In this case a Nitrile element can be used with a 150 Jaw coupling.

4. Bore Size

By referring to the standard bore and keyway table it can be seen that both shaft diameters fall within the bore range available.

Service Factors

		Type of driving unit: Electric motors and steam Turbines			Type of driving unit: Internal combustion engines, steam engines and water turbines		
		Duty hours per day			Duty hours per day		
		Up to 10	10 to 16	Over 16	Up to 10	10 to 16	Over 16
Light	Agitators/Mixers [liquids], belt conveyors [uniform loading], blowers and exhausters, centrifugal pumps and compressors, fans [below 7,5 kW]	1	1,1	1,2	1,5	1,6	1,7
Medium	Agitators/Mixers [non-liquid], Belt and chain conveyors [variable loading], fans [over 7,5 kW], generators, line shafts, machine tools, rotary pumps and compressors [other than centrifugal] Machinery for food processing, laundries and printing industries	1,5	1,6	1,7	2	2,1	2,3
Heavy	Heavy duty conveyors [bucket, drag/shovel, screw], hammer mills, presses, punches, shears, piston pumps and compressors Machinery for brick, textile, paper, saw mill industries	2	2,1	2,3	2,5	2,6	2,8
Very Heavy	Crushers [gyratory, jaw, roll], Heavy duty mills [ball, rod, tube], Hoists	2,5	2,8	3	3,2	3,5	4



Jaw couplings

Selection

- ▶ Belts
- ▶ Chains
- ▶ Couplings
- ▶ Bushings and Hubs
- ▶ Sprockets
- ▶ Pulleys
- ▶ Smart tools

Elements

Type	Temperature Range (°C)	Misalignment		Power Factor
		Angular °	Parallel mm	
Nitrile	-40 to 100	1	0,38	1
Urethane	-35 to 70	1	0,38	1,5
Hytrel®	-50 to 120	0,5	0,38	3

Power Ratings (kW) – Nitrile Elements

Speed	Coupling Size									
	50	70	75	90	95	100	110	150	190	225
RPM										
50	0,018	0,030	0,06	0,10	0,14	0,3	0,5	0,8	1,1	1,5
100	0,037	0,060	0,12	0,20	0,27	0,6	1,1	1,6	2,1	2,9
200	0,074	0,121	0,25	0,40	0,54	1,2	2,2	3,1	4,2	5,9
300	0,110	0,181	0,37	0,60	0,81	1,7	3,3	4,7	6,3	8,8
400	0,147	0,242	0,50	0,80	1,08	2,3	4,4	6,3	8,4	11,7
500	0,184	0,302	0,62	1,01	1,35	2,9	5,5	7,9	10,5	14,7
600	0,221	0,363	0,75	1,21	1,62	3,5	6,6	9,4	12,6	17,6
700	0,257	0,423	0,87	1,41	1,89	4,1	7,7	11,0	14,7	20,5
720	0,265	0,435	0,90	1,45	1,95	4,2	7,9	11,3	15,1	21,1
800	0,294	0,483	1,00	1,61	2,16	4,6	8,8	12,6	16,8	23,5
900	0,331	0,544	1,12	1,81	2,43	5,2	9,9	14,1	18,8	26,4
960	0,353	0,580	1,20	1,93	2,59	5,6	10,6	15,1	20,1	28,1
1000	0,368	0,604	1,25	2,01	2,70	5,8	11,0	15,7	20,9	29,3
1200	0,441	0,725	1,50	2,41	3,24	7,0	13,2	18,8	25,1	35,2
1400	0,515	0,846	1,74	2,81	3,78	8,1	15,4	22,0	29,3	41,1
1440	0,529	0,870	1,79	2,90	3,89	8,4	15,8	22,6	30,2	42,2
1600	0,588	0,967	1,99	3,22	4,32	9,3	17,6	25,1	33,5	46,9
1800	0,662	1,088	2,24	3,62	4,86	10,4	19,8	28,3	37,7	52,8
2000	0,735	1,208	2,49	4,02	5,40	11,6	22,0	31,4	41,9	58,6
2200	0,809	1,329	2,74	4,42	5,94	12,8	24,2	34,6	46,1	64,5
2400	0,882	1,450	2,99	4,83	6,48	13,9	26,4	37,7	50,3	70,4
2600	0,956	1,571	3,24	5,23	7,02	15,1	28,6	40,8	54,5	76,2
2800	1,029	1,692	3,49	5,63	7,56	16,2	30,8	44,0	58,6	82,1
2880	1,059	1,740	3,59	5,79	7,78	16,7	31,7	45,2	60,3	84,4
3000	1,103	1,813	3,74	6,03	8,10	17,4	33,0	47,1	62,8	88,0
3600	1,323	2,175	4,49	7,24	9,73	20,9	39,6	56,5	75,4	105,5
Nominal Torque Nm	3,51	5,77	11,9	19,2	25,8	55,4	105	150	200	280

Data is for standard Nitrile element. For both nominal torque of Urethane and Hytrel multiply nominal torques of Nitrile by element power factors. For speeds not shown calculate the nominal torque for the design application using the formula below and select coupling according to nominal torque ratings.

$$\text{Nominal Torque (Nm)} = \frac{\text{Design power (kW)} \times 30000}{\text{RPM} \times \pi}$$



Jaw couplings

Selection



Standard Bore and Keyway Chart

Bore	Keyway	Coupling Size									
		050	070	075	090	095	100	110	150	190	225
9	3 x 1,4	X	X	X	X	-	-	-	-	-	-
10	3 x 1,4	X	X	X	X	-	-	-	-	-	-
11	4 x 1,8	X	X	X	X	-	-	-	-	-	-
12	4 x 1,8	X	X	X	X	X	-	-	-	-	-
14	5 x 2,3	X	X	X	X	X	X	-	-	-	-
15	5 x 2,3	-	X	X	X	X	X	-	-	-	-
16	5 x 2,3	-	X	X	X	X	X	X	X	-	-
17	5 x 2,3	-	X	X	X	X	X	X	X	-	-
18	6 x 2,8	-	X	X	X	X	X	X	X	-	-
19	6 x 2,8	-	X	X	X	X	X	X	X	X	-
20	6 x 2,8	-	-	X	X	X	X	X	X	X	-
22	6 x 2,8	-	-	X	X	X	X	X	X	X	-
24	8 x 3,3	-	-	-	X	X	X	X	X	X	X
25	8 x 3,3	-	-	-	-	X	X	X	X	X	X
28	8 x 3,3	-	-	-	-	X	X	X	X	X	X
30	8 x 3,3	-	-	-	-	-	X	X	X	X	X
32	10 x 3,3	-	-	-	-	-	X	X	X	X	X
35	10 x 3,3	-	-	-	-	-	X	X	X	X	X
38	10 x 3,3	-	-	-	-	-	X	X	X	X	X
40	12 x 3,3	-	-	-	-	-	-	X	X	X	X
42	12 x 3,3	-	-	-	-	-	-	X	X	X	X
45	14 x 3,8	-	-	-	-	-	-	-	X	X	X
48	14 x 3,8	-	-	-	-	-	-	-	X	X	X
50	14 x 3,8	-	-	-	-	-	-	-	-	X	X
55	16 x 4,3	-	-	-	-	-	-	-	-	X	X
60	18 x 4,4	-	-	-	-	-	-	-	-	-	X

Designations

Size	Hub Type L	Element				Ring Kit	Spacer	
		Nitrile Standard	Nitrile Wrap	Urethane	Hytrel®		100 mm	140 mm
35	PHE L035HUB	PHE L035NR	-	PHE L035UR	PHE L035HL	-	-	-
50	PHE L050HUB	PHE L050NR	-	PHE L050UR	PHE L050HL	-	-	-
70	PHE L070HUB	PHE L070NR	-	PHE L070UR	PHE L070HL	-	-	-
75	PHE L075HUB	PHE L075NR	-	PHE L075UR	PHE L075HL	-	-	-
90	PHE L090HUB	PHE L090/095NR	-	PHE L090/095UR	PHE L090/095HL	-	-	-
95	PHE L095HUB	PHE L090/095NR	PHE L095NRWRAP	PHE L090/095UR	PHE L090/095HL	PHE L095RINGKIT	PHE L095X100SPACER	PHE L095X140SPACER
100	PHE L100HUB	PHE L100NR	PHE L100NRWRAP	PHE L100UR	PHE L100HL	PHE L100RINGKIT	PHE L100X100SPACER	PHE L100X140SPACER
110	PHE L110HUB	PHE L110NR	PHE L110NRWRAP	PHE L110UR	PHE L110HL	PHE L110RINGKIT	PHE L110X100SPACER	PHE L110X140SPACER
150	PHE L150HUB	PHE L150NR	PHE L150NRWRAP	PHE L150UR	PHE L150HL	PHE L150RINGKIT	PHE L150X100SPACER	PHE L150X140SPACER
190	PHE L190HUB	PHE L190NR	PHE L190NRWRAP	PHE L190UR	PHE L190HL	PHE L190RINGKIT	PHE L190X100SPACER	PHE L190X140SPACER
225	PHE L225HUB	PHE L225NR	PHE L225NRWRAP	PHE L225UR	PHE L225HL	PHE L225RINGKIT	PHE L225X100SPACER	PHE L225X140SPACER

When ordering bored to size and keywayed hubs it is required that the bore diameter is added to the designation found in the table above.

Where a keyway is NOT required the designation should be suffixed with a P.

PHE L150-18MM = Hub Size 150 with 18 mm bore and keyway

PHE L070-16MMP = Hub Size 070 with 16 mm bore (no keyway)

A complete coupling consists of 2 hubs and 1 element.

A complete coupling with spacer consists of 2 hubs, 2 ring kits and 1 spacer.



Jaw couplings

Dimensions

- ▶ Belts
- ▶ Chains
- ▶ Couplings
- ▶ Bushings and Hubs
- ▶ Sprockets
- ▶ Pulleys
- ▶ Smart tools

Hubs & Spacers

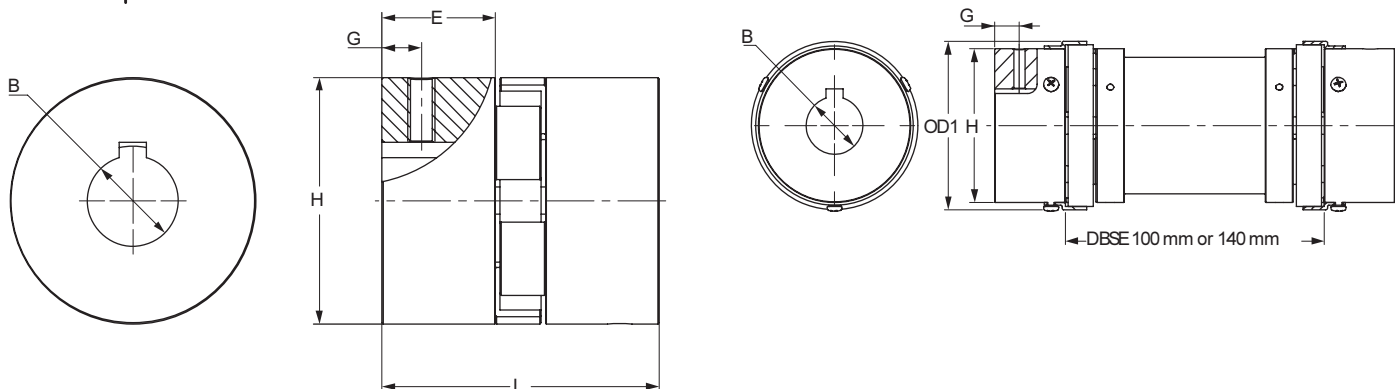

Jaw coupling spacers are available in 100 mm or 140 mm lengths for sizes 090 to 225. Jaw couplings are used with “snap wrap” Nitrile elements to allow spacer removal and axial shaft movement without disturbing either driving or driven machines.

Dimensions

Size	Dimensions								Set Screw	Approx + mass	Max Speed
	B		OD	OD1*	L	E	H	G			
	Pilot	Max	mm	mm	mm	mm	mm	mm		kg	RPM
35	3,20	9,5	15,9	–	20,6	6,7	15,9	–	–	0,03	31000
50	6,35	14,0	27,5	–	44,0	16,0	27,5	6,5	M6	0,05	18000
70	6,35	19,0	35,0	–	51,0	19,0	35,0	9,5	M6	0,12	14000
75	6,35	24,0	44,5	–	54,0	21,0	44,5	9,0	M6	0,22	11000
90	6,35	24,0	54,0	–	54,0	21,0	54,0	8,7	M6	0,28	9000
95	11,11	28,0	54,0	64	64,0	25,0	54,0	11,0	M8	0,31	9000
100	12,70	35,0	65,0	77	89,0	35,0	65,0	11,0	M8	0,75	7000
110	15,87	42,0	84,0	97	108,0	43,0	84,0	19,0	M10	1,50	5000
150	15,87	48,0	96,0	112	115,0	45,0	96,0	22,0	M10	2,40	4000
190	19,05	55,0	115,0	130	133,0	54,0	102,0	22,0	M12	3,50	3600
225	19,05	60,0	127,0	143	153,0	64,0	108,0	29,0	M12	4,50	3600

* Outer diameter of ring kit

+ Mass of hub with pilot bores

DBSE = Distance between shaft ends

Hub material is high grade cast iron. Spacer material is aluminium.



Universal joints



Single Universal Joints

For use on shafts up to 1800 rev/min and working angles up to 25° (powered) or 35° (hand operated).

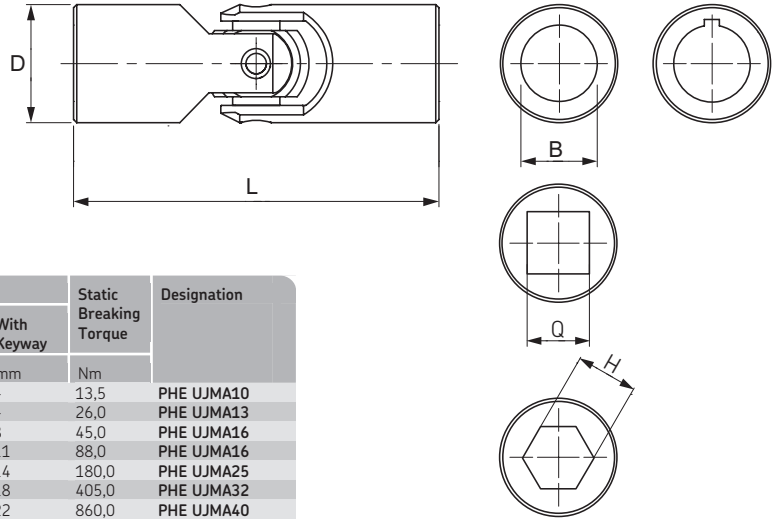

Size	L	D	Bore			B Max		Static Breaking Torque	Designation
			B	Q	H	Bore	With Keyway		
	mm	mm	mm	mm	mm	mm	mm	Nm	
UJMA10	38	10	6	6	6	6	-	13,5	PHE UJMA10
UJMA13	45	13	8	8	8	8	-	26,0	PHE UJMA13
UJMA16	52	16	8	8	8	10	8	45,0	PHE UJMA16
UJMA20	62	20	10	10	10	13	11	88,0	PHE UJMA16
UJMA25	74	25	12	12	12	16	14	180,0	PHE UJMA25
UJMA32	86	32	16	16	16	22	18	405,0	PHE UJMA32
UJMA40	108	40	20	20	20	25	22	860,0	PHE UJMA40
UJMA45	120	45	20	20	20	30	25	1250,0	PHE UJMA45
UJMA50	132	50	25	25	25	35	30	1730,0	PHE UJMA50
UJMA63	166	63	32	32	-	45	35	3400,0	PHE UJMA63
UJMA75	190	75	40	40	-	55	45	5300,0	PHE UJMA75

Standard is without bore.

Available on request with finish bore H7 - on request with keyway -(B), hexagon bore (H) or square bore (Q).

Double Universal Joints

For use on constant velocity driven shafts or where parallel misalignment is required. Working angles up to 25° (powered) or 35° (hand operated).

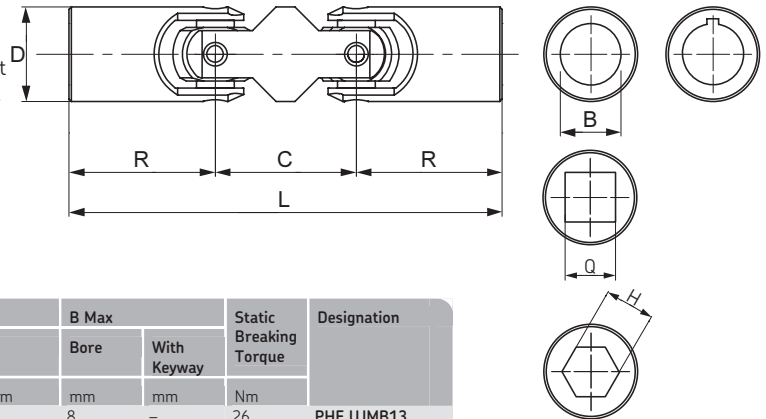

Size	L	R	D	C	Bore			B Max		Static Breaking Torque	Designation
					B	Q	H	Bore	With Keyway		
	mm	mm	mm	mm	mm	mm	mm	mm	mm	Nm	
UJMB13	68	22,5	13	23	8	8	8	8	-	26	PHE UJMB13
UJMB16	77	26,0	16	25	8	8	8	10	8	45	PHE UJMB16
UJMB20	92	31,0	20	30	10	10	10	13	11	88	PHE UJMB20
UJMB25	110	37,0	25	36	12	12	12	16	14	180	PHE UJMB25
UJMB32	133	43,0	32	47	16	16	16	22	18	405	PHE UJMB32
UJMB40	164	54,0	40	56	20	20	20	25	22	860	PHE UJMB40
UJMB45	183	60,0	45	63	20	20	20	30	25	1250	PHE UJMB45
UJMB50	202	66,0	50	70	25	25	25	35	30	1730	PHE UJMB50
UJMB63	250	83,0	63	84	32	32	-	45	35	3400	PHE UJMB63
UJMB75	290	95,0	75	100	40	40	-	55	45	5300	PHE UJMB75

Standard is without bore.

Available on request with finish bore H7 - on request with keyway -(B), hexagon bore (H) or square bore (Q).

Bushings and Hubs





Taper bushings

Sizes 1008 - 120100



1008 - 3030

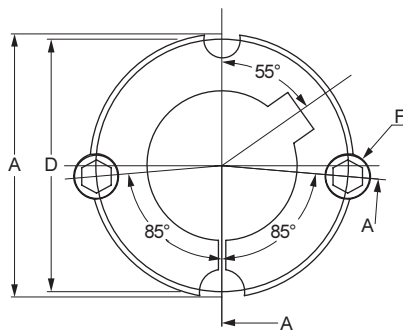

Section A-A

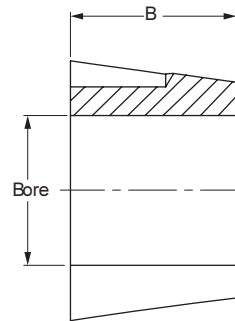

3525 - 5050

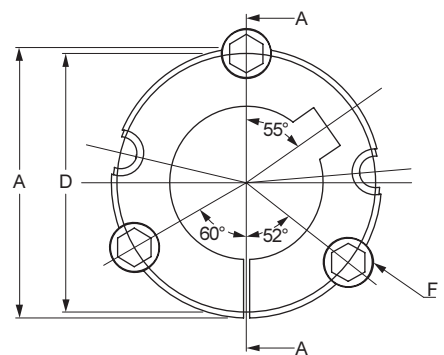

Dimensions

Bushing Size	Bore				A	B	D	F	Weight	Designation
	Min		Max							
	mm	inch	mm	inch						
1008	9	3/8	25	1	35,2	22,2	33,7	6,350 x 12,700	0,05	PHF TB1008X...
1108	9	3/8	28	1 1/8	38,4	22,2	36,9	6,350 x 12,700	0,08	PHF TB1108X...
1210	11	1/2	32	1 1/4	47,6	25,4	44,5	9,525 x 15,875	0,19	PHF TB1210X...
1215	11	1/2	32	1 1/4	47,6	38,1	44,5	9,525 x 15,875	0,27	PHF TB1215X...
1610	14	1/2	42	1 5/8	57,2	25,4	54,0	9,525 x 15,875	0,31	PHF TB1610X...
1615	14	1/2	42	1 5/8	57,2	38,1	54,0	9,525 x 15,875	0,46	PHF TB1615X...
2012	14	1/2	50	2	69,9	31,8	66,7	11,113 x 22,225	0,65	PHF TB2012X...
2017	14	1/2	50	2	69,9	44,5	66,7	11,113 x 22,225	0,91	PHF TB2017X...
2517	16	1/2	60	2 1/2	85,7	44,5	82,6	12,700 x 25,400	1,47	PHF TB2517X...
2525	16	1/2	60	2 1/2	85,7	63,5	82,6	12,700 x 25,400	4,30	PHF TB2525X...
3020	25	1	75	3	108,0	50,8	101,6	15,875 x 31,750	2,25	PHF TB3020X...
3030	35	1	75	3	108,0	76,2	101,6	15,875 x 31,750	3,25	PHF TB3030X...
3525	35	1 1/4	100	4	127,0	63,5	123,0	12,700 x 38,10	4,23	PHF TB3525X...
3535	35	1 1/4	90	3 1/2	127,0	89,0	123,0	12,700 x 38,10	5,78	PHF TB3535X...
4030	40	1 1/4	115	4 1/4	146,0	76,2	141,0	15,875 x 44,45	7,00	PHF TB4030X...
4040	40	1 3/4	100	4	146,0	102,0	141,0	15,875 x 44,45	9,20	PHF TB4040X...
4535	55	2	125	5	161,0	89,0	156,0	19,050 x 50,800	9,10	PHF TB4535X...
4545	55	2	120	4 1/2	161,0	114,0	156,0	19,050 x 50,800	11,80	PHF TB4545X...
5040	70	2 5/8	140	5 1/2	178,0	101,6	171,0	22,255 x 57,150	12,26	PHF TB5040X...
5050	70	2 5/8	125	5	178,0	127,0	171,0	22,255 x 57,150	15,18	PHF TB5050X...

6050

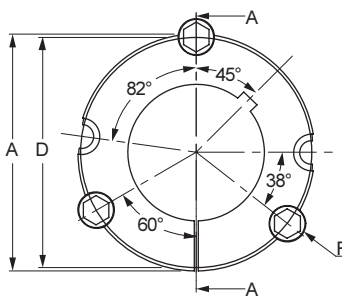

7060 to 10085a

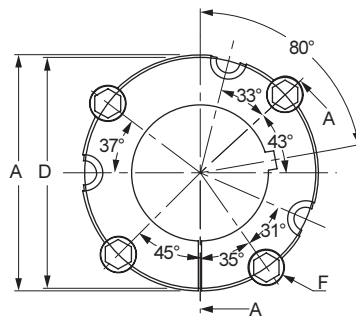

120100

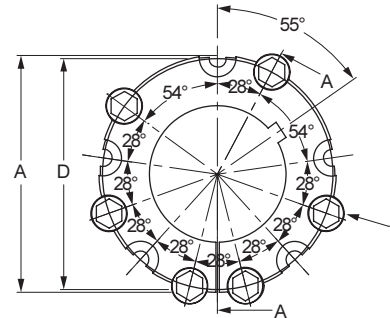

Section A-A

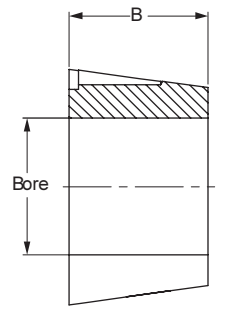

Dimensions 6050 - 120100

Bushing Size	Bore				A	B	D	E	F	Weight	Designation
	Min		Max								
	mm	inch	mm	inch							
6050	95	3 7/8	150	6	235,0	127,0	228,6	171,5	31,8 x 88,9	25	PHF TB6050X...
7060	110	4 3/8	170	7	260,4	152,4	254,0	196,9	31,8 x 88,9	34	PHF TB7060X...
8065	130	5 1/16	190	8	285,8	165,1	279,4	222,3	31,8 x 88,9	45	PHF TB8065X...
10085	170	6 7/16	260	10	374,7	215,9	368,3	298,5	38,1 x 114,3	104	PHF TB10085X...
120100	200	7 7/16	290	12	438,2	254,0	431,8	362,0	38,1 x 114,3	163	PHF TB120100X...

Note: Bushings cannot be bored out larger than listed

Numbers of screws as follows: 1008 - 3030 (2 screws); 3525 - 6050 (3 screws); 7060 - 10085 (4 screws); and 120100 (6 screws). Bushings are supplied with screws. A is the diameter at the face of the bush and D is the diameter at the tapered end

+ To complete designation add bore size. For example: PHF TB1215X16MM designates a 1215 taper bushing with a 16 mm bore



Taper bushings

Dimensions

- ▶ Belts
- ▶ Chains
- ▶ Couplings
- ▶ Bushings and Hubs
- ▶ Sprockets
- ▶ Pulleys
- ▶ Smart tools

Metric Bores and keyway

Bore diameter	Keyway		Shallow keyway depth	Bore sizes available																	
	Width	Depth		1008	1108	1210	1610	1615	2012	2517	3020	3030	3525	3535	4030	4040	4535	4545	5040	5050	
mm	mm	mm	mm																		
9	3	1,4	-	•	•																
10	3	1,4	-	•	•																
11	4	1,8	-	•	•	•															
12	4	1,8	-	•	•																
14	5	2,3	-	•	•	•	•	•	•												
15	5	2,3	-	•	•	•	•	•	•												
16	5	2,3	-	•	•	•	•	•	•	•											
18	6	2,8	-	•	•	•	•	•	•	•											
19	6	2,8	-	•	•	•	•	•	•	•											
20	6	2,8	-	•	•	•	•	•	•	•											
22	6	2,8	-	•	•	•	•	•	•	•											
24	8	3,3	1,3	•*	•	•	•	•	•	•											
25	8	3,3	1,3	•*	•	•	•	•	•	•	•										
28	8	3,3	1,3		•*	•	•	•	•	•	•										
30	8	3,3	-		•	•	•	•	•	•	•										
32	10	3,3	-			•	•	•	•	•	•										
35	10	3,3	-			•	•	•	•	•	•	•									
38	10	3,3	-			•	•	•	•	•	•	•	•								
40	12	3,3	1,3				•	•*	•	•	•	•	•	•							
42	12	3,3	1,3				•	•*	•	•	•	•	•	•	•						
45	14	3,8	-					•	•	•	•	•	•	•	•						
48	14	3,8	-					•	•	•	•	•	•	•	•						
50	14	3,8	-					•	•	•	•	•	•	•	•						
55	16	4,3	-						•	•	•	•	•	•	•	•					
60	18	4,4	-						•	•	•	•	•	•	•	•	•				
65	18	4,4	-							•	•	•	•	•	•	•	•				
70	20	4,9	-							•	•	•	•	•	•	•	•				
75	20	4,9	-							•	•	•	•	•	•	•	•				
80	22	5,4	-								•	•	•	•	•	•	•	•			
85	22	5,4	-								•	•	•	•	•	•	•	•			
90	25	5,4	-									•	•	•	•	•	•	•			
95	25	5,4	-									•	•	•	•	•	•	•			
100	28	6,4	4,4									•*	•	•	•	•	•	•			
105	28	6,4	-										•	•	•	•	•	•			
110	28	6,4	-											•	•	•	•	•			
115	32	7,4	5,4											•*	•	•	•	•			
120	32	7,4	-												•	•	•	•			
125	32	7,4	-													•	•	•			
130	32	7,4	-														•	•			
140	32	8,4	6,4															•*			

* Bushing comes with a shallow keyway

Taper bushings

Dimensions



Inch Bores and keyway

Bore diameter	Keyway		Shallow keyway depth	Bore sizes available																	
	Width	Depth		1008	1108	1210	1610	1615	2012	2517	3020	3030	3525	3535	4030	4040	4535	4545	5040	5050	
inch	inch	inch	inch																		
3/8	1/8	1/16	-	•	•																
1/2	1/8	1/16	-	•	•																
5/8	3/32	3/32	-	•	•	•	•	•	•	•											
3/4	3/32	3/32	-	•	•	•	•	•	•	•											
7/8	1/4	1/8	-	•	•	•	•	•	•	•											
1	1/4	1/8	1/16	•*	•	•	•	•	•	•	•	•									
1 1/8	5/16	1/8	5/64		•*	•	•	•	•	•	•	•									
1 1/4	5/16	1/8	-		•	•	•	•	•	•	•	•									
1 3/8	3/8	1/8	-		•	•	•	•	•	•	•	•									
1 1/2	3/8	1/8	-		•	•	•	•	•	•	•	•	•								
1 5/8	7/16	5/32	1/8			•	•*	•	•	•	•	•	•								
1 3/4	7/16	5/32	-			•	•	•	•	•	•	•	•								
1 7/8	1/2	5/32	-			•	•	•	•	•	•	•	•	•							
2	1/2	5/32	-			•	•	•	•	•	•	•	•	•							
2 1/8	5/8	7/32	-					•	•	•	•	•	•	•	•						
2 1/4	5/8	7/32	-						•	•	•	•	•	•	•						
2 3/8	5/8	7/32	-						•	•	•	•	•	•	•						
2 1/2	5/8	7/32	-						•	•	•	•	•	•	•						
2 5/8	3/4	1/4	-							•	•	•	•	•	•	•					
2 3/4	3/4	1/4	-							•	•	•	•	•	•	•					
2 7/8	3/4	1/4	-							•	•	•	•	•	•	•					
3	3/4	1/4	-							•	•	•	•	•	•	•					
3 1/8	7/8	5/16	-								•	•	•	•	•	•					
3 1/4	7/8	5/16	-								•	•	•	•	•	•					
3 3/8	7/8	5/16	-								•	•	•	•	•	•					
3 1/2	7/8	5/16	-								•	•	•	•	•	•					
3 3/4	1	3/8	5/16								•	•*	•	•	•	•					
4	1	3/8	7/32								•	•*	•	•	•	•					
4 1/4	1 1/4	7/16	-										•	•	•	•					
4 1/2	1 1/4	7/16	11/32											•*	•	•					
4 3/4	1 1/4	7/16	-												•	•					
5	1 1/4	7/16	11/32													•*					

* Bushing comes with a shallow keyway



Weld-on hubs

- ▶ Belts
- ▶ Chains
- ▶ Couplings
- ▶ Bushings and Hubs
- ▶ Sprockets
- ▶ Pulleys
- ▶ Smart tools

Type W taper bushed weld-on hubs

Hub	Bushing Size	OD	B	C	L	E	F	Designation
		mm	mm	mm	mm	mm	mm	
W12	1215	73,03	63,50	62,71	38,1	15,88	9,53	PHH W12
W16	1615	82,55	73,03	72,24	38,1	15,88	9,53	PHH W16
W20	2017	101,60	88,90	88,11	44,4	19,05	11,91	PHH W20
W25	2517	127,00	111,13	110,34	44,4	19,05	12,70	PHH W25
W30	3030	149,86	133,35	132,56	76,2	25,40	19,05	PHH W30
W35	3535	184,15	158,75	157,96	88,9	31,75	25,40	PHH W35
W40	4040	225,43	196,85	196,06	101,6	31,75	31,75	PHH W40
W45	4545	254,00	222,25	221,46	114,3	38,10	38,10	PHH W45

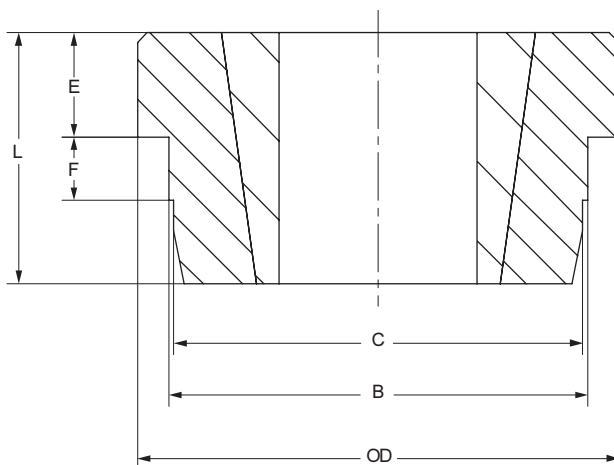

Type WH taper bushed weld-on hubs

Hub	Bushing Size	OD	B	C	L	E	F	Designation
		mm	mm	mm	mm	mm	mm	
WH12	1210	70	65	64,5	25	9	10	PHH WH12
WH16	1610	80	75	74,5	25	9	10	PHH WH16
WH20	2012	95	90	89,5	32	12	12	PHH WH20
WH25	2517	115	110	109,5	44	19	15	PHH WH25
WH30	3020	145	140	139,5	50	20	15	PHH WH30
WH35-2	3535	190	180	179,5	89	25	25	PHH WH35-2
WH40-1	4030	200	190	189,5	76	32	30	PHH WH40-1
WH40-2	4040	200	190	189,5	101	32	30	PHH WH40-2
WH45-1	4535	210	200	199,5	89	40	30	PHH WH45-1
WH45-2	4545	210	200	199,5	114	40	30	PHH WH45-2
WH50-1	5040	230	220	219,5	102	40	35	PHH WH50-1
WH50-2	5050	230	220	219,5	127	40	35	PHH WH50-2

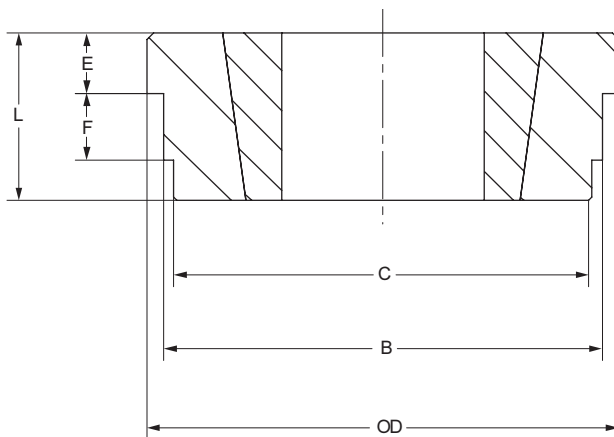

Type WM taper bushed weld-on hubs

Hub	Bushing Size	OD	B	C	L	E	F	Designation
		mm	mm	mm	mm	mm	mm	
WM12	1210	70	60	58	25	9	10	PHH WM12
WM16-1	1610	83	70	68	25	9	10	PHH WM16-1
WM16-2	1615	83	70	68	38	16	11	PHH WM16-2
WM20	2012	95	90	88	32	12	12	PHH WM20
WM25	2517	127	110	108	44	19	13	PHH WM25
WM30-1	3020	152	130	125	50	20	15	PHH WM30-1
WM30-2	3030	152	130	125	76	25	19	PHH WM30-2
WM35	3535	184	155	151	89	32	25	PHH WM35
WM40	4040	225	195	187	102	32	32	PHH WM40
WM45	4545	254	220	213	114	38	38	PHH WM45
WM50	5050	276	242	228	127	38	38	PHH WM50

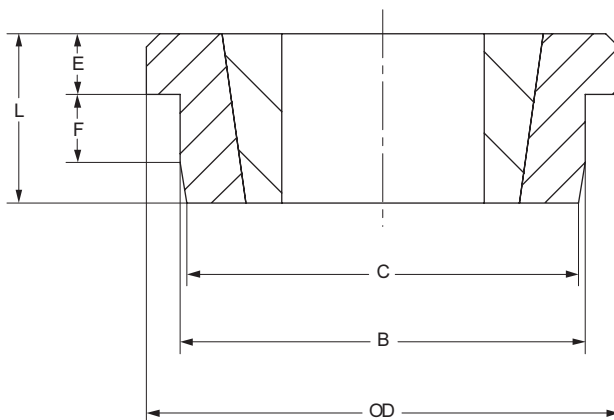



Bolt-on hubs / adapters



Type BF taper bushed bolt-on hubs

Hub	Bushing Size	OD	B	BC	L	E	J*	Designation
		mm	mm	mm	mm	mm	mm	
BF12	1210	120	80	100	25	6,5	6 x 6,6	PHH BF12
BF16	1610	130	90	110	25	6,5	6 x 6,6	PHH BF16
BF20	2012	145	100	125	32	8,5	6 x 9,0	PHH BF20
BF25	2517	185	130	155	44	11,5	6 x 11,0	PHH BF25
BF30	3020	220	165	190	50	11,5	6 x 13,0	PHH BF30

* Number of screw holes x hole diameter

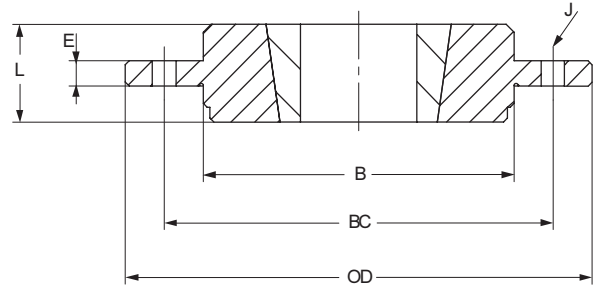

Type SM taper bushed bolt-on hubs

Hub	Bushing Size	OD	B	BC	L	E	H	J*	Designation
		mm	mm	mm	mm	mm	mm	mm	
SM12	1210	180	90	135	25	6,5	75	6 x 7,5	PHH SM12
SM16	1615	200	110	150	38	7,5	85	6 x 7,5	PHH SM16
SM20	2012	270	140	190	32	8,5	110	6 x 9,5	PHH SM20
SM25	2517	340	170	240	45	9,5	125	8 x 11,5	PHH SM25
SM30-1	3020	430	220	300	51	13,5	160	8 x 13,5	PHH SM30-1
SM30-2	3020	485	250	340	51	13,5	160	8 x 13,5	PHH SM30-2

* Number of screw holes x hole diameter

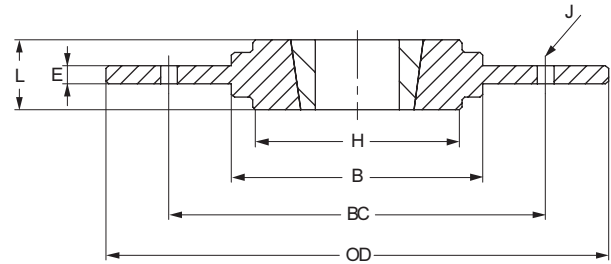

Taper bushed adapters

Adapter	Bushing Size	OD	L	Keyway		Designation
				Width	Depth	
				mm	mm	
1008KM	1008	45	22	5	2,5	PHH TBA1008KM
1008PM	1008	45	22	-	-	PHH TBA1008PM
1210KM	1210	60	25	6	3,0	PHH TBA1210KM
1210PM	1210	60	25	-	-	PHH TBA1210PM
1215KM	1215	60	38	6	3,0	PHH TBA1215KM
1215PM	1215	60	38	-	-	PHH TBA1215PM
1610KM	1610	70	25	10	4,0	PHH TBA1610KM
1610PM	1610	70	25	-	-	PHH TBA1610PM
1615KM	1615	70	38	10	4,0	PHH TBA1615KM
1615PM	1615	70	38	-	-	PHH TBA1615PM
2517KM	2517	105	45	16	4,0	PHH TBA2517KM
2517PM	2517	105	45	-	-	PHH TBA2517PM
3030KM	3030	130	76	20	5,0	PHH TBA3030KM
3030PM	3030	130	76	-	-	PHH TBA3030PM
3535KM	3535	160	89	22	5,0	PHH TBA3535KM
3535PM	3535	160	89	-	-	PHH TBA3535PM
4040KM	4040	185	102	24	5,0	PHH TBA4040KM
4040PM	4040	185	102	-	-	PHH TBA4040PM

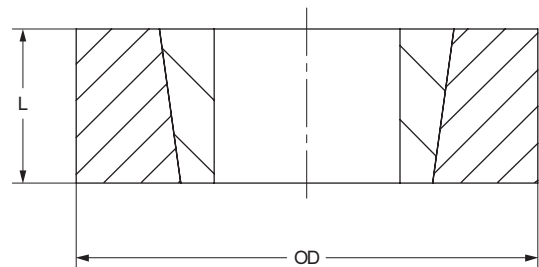

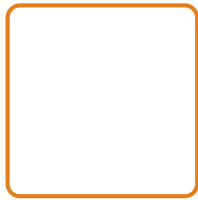

QD Bushings

- ▶ Belts
- ▶ Chains
- ▶ Couplings
- ▶ Bushings and Hubs
- ▶ Sprockets
- ▶ Pulleys
- ▶ Smart tools

Size JA-J

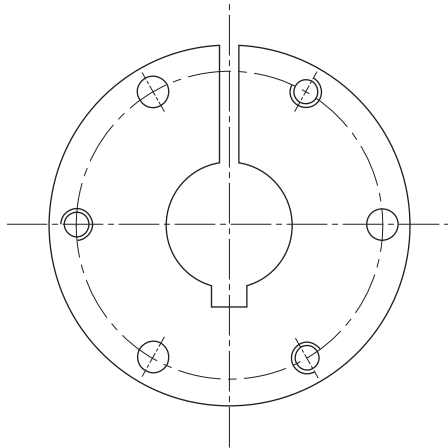

Size M-S

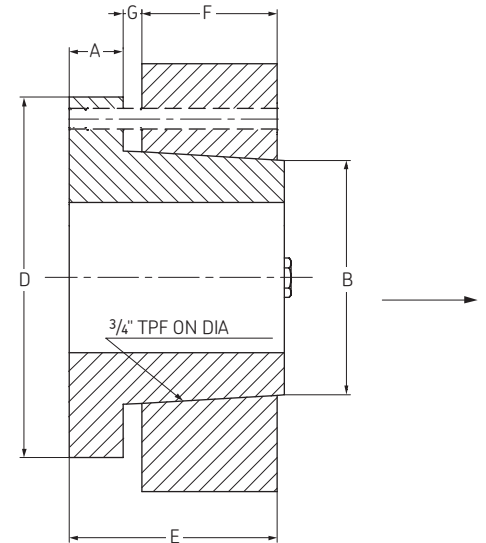
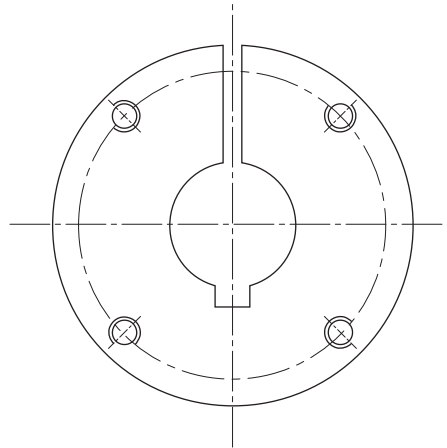

Bushing ID	Bore range for min	Bore range for max		A	B	D	E	F	G	Set screw size	Average weight		Designation
		Std key way	Shallow key way								kg	lbs	
		Inch	Inch										
JA	3/8	1	1 1/4	0,31	1,38	2,00	1,00	0,56	0,12	10 - 24	0,4	0,9	PHF JA...
SH	1/2	1 3/8	1 13/16	0,43	1,88	2,63	1,31	0,81	0,12	1/4	0,5	1,0	PHF SH...
SDS	1/2	1 11/16	2	0,43	2,18	3,18	1,31	0,75	0,12	1/4	0,7	1,0	PHF SDS...
SD	1/2	1 11/16	1 15/16	0,43	2,18	3,18	1,81	1,25	0,12	1/4	0,9	1,5	PHF SD...
SK	1/2	2 1/8	2 1/2	0,56	2,81	3,88	1,93	1,25	0,22	1 5/16	0,9	2,0	PHF SK...
SF	1/2	2 15/16	2 13/16	0,63	3,13	4,63	2,06	1,25	0,22	1 5/16	2,2	3,0	PHF SF...
E	7/8	2 7/8	3 1/2	0,88	3,83	6,00	2,75	1,63	0,25	3/8	4,6	10,0	PHF E...
F	1	3 15/16	3 15/16	1,00	4,43	6,63	3,75	2,50	0,34	1/2	7,6	11,5	PHF F...
J	1 7/16	3 3/4	4 1/2	1,13	5,14	7,25	4,63	3,18	0,38	1 5/8	8,2	18,0	PHF J...
M	2 15/16	4 3/4	5 1/2	1,25	6,50	9,00	6,75	5,18	0,41	3/4	27,0	37,0	PHF M...
N	2 7/16	5 1/8	6	1,50	7,00	10,00	8,12	6,25	0,56	3/4	37,5	57,0	PHF N...
P	2 15/16	5 15/16	7	1,75	8,25	11,75	9,38	7,25	0,63	7/8	54,4	120,0	PHF P...
W	4	7 1/2	8 1/2	2,00	10,42	15,00	11,38	9,00	0,50	1	113,4	250,0	PHF W...
S	6	8 1/4	10	2,75	12,13	17,75	15,25	12,00	0,75	1 1/4	181,4	400,0	PHF S...

To complete the designation add bore size in inch or millimetres (standard bore sizes available on next page).
 Eg.: PHF SDS-1-11/16 and PHF SDS-25MM.



QD Bushings

Dimensions



Inch bores and keyway

Bushing	Bores	Keyway
JA	$\frac{3}{8}$ - $\frac{7}{16}$	No Keyway
	$\frac{1}{2}$ - 1	STD
	$1 \frac{1}{8}$ - $1 \frac{1}{8}$	$\frac{1}{4} \times \frac{1}{16}$
	$1 \frac{3}{16}$	$\frac{1}{4} \times \frac{1}{16}$
	$1 \frac{1}{4}$	No Keyway
SH	$\frac{1}{2}$ - $1 \frac{3}{8}$	STD
	$1 \frac{7}{16}$ - $1 \frac{1}{2}$	$\frac{3}{8} \times \frac{1}{16}$
	$1 \frac{9}{16}$ - $1 \frac{5}{8}$	$\frac{3}{8} \times \frac{1}{16}$
	$1 \frac{11}{16}$	No Keyway
SDS	$\frac{1}{2}$ - $1 \frac{11}{16}$	STD
	$1 \frac{3}{4}$	$\frac{3}{8} \times \frac{1}{8}$
	$1 \frac{13}{16}$	$\frac{1}{2} \times \frac{1}{8}$
	$1 \frac{7}{8}$ - $1 \frac{15}{16}$	$\frac{1}{2} \times \frac{1}{16}$
	2	No Keyway
SD	$\frac{1}{2}$ - $1 \frac{11}{16}$	STD
	$1 \frac{3}{4}$	$\frac{3}{8} \times \frac{1}{8}$
	$1 \frac{13}{16}$	$\frac{1}{2} \times \frac{1}{8}$
	$1 \frac{7}{8}$	$\frac{1}{2} \times \frac{1}{16}$
	$1 \frac{15}{16}$	$\frac{1}{2} \times \frac{1}{16}$
SK	2	No Keyway
	$\frac{1}{2}$ - 2 $\frac{1}{8}$	STD
	$2 \frac{3}{16}$ - $2 \frac{1}{4}$	$\frac{1}{2} \times \frac{1}{8}$
	$2 \frac{5}{16}$ - $2 \frac{1}{2}$	$1 \frac{7}{8} \times \frac{1}{16}$
SF	$2 \frac{7}{16}$ - $2 \frac{5}{8}$	No Keyway
	$\frac{1}{2}$ - $2 \frac{1}{4}$	STD
	$2 \frac{3}{16}$ - $2 \frac{1}{2}$	$1 \frac{9}{8} \times \frac{3}{16}$
	$2 \frac{9}{16}$ - $2 \frac{3}{4}$	$\frac{5}{8} \times \frac{1}{16}$
	$2 \frac{13}{16}$ - $2 \frac{7}{8}$	$\frac{3}{4} \times \frac{1}{16}$
E	$2 \frac{15}{16}$	$\frac{3}{4} \times \frac{1}{32}$
	$\frac{7}{8}$ - $2 \frac{7}{8}$	STD
	$2 \frac{15}{16}$ - $3 \frac{1}{4}$	$\frac{3}{4} \times \frac{1}{8}$
F	$3 \frac{3}{8}$ - $3 \frac{1}{2}$	$\frac{7}{8} \times \frac{1}{16}$
	1 - $3 \frac{3}{16}$	STD
	$3 \frac{3}{8}$ - $3 \frac{3}{4}$	$\frac{7}{8} \times \frac{3}{16}$
J	$3 \frac{7}{8}$ - $3 \frac{15}{16}$	$1 \times \frac{1}{8}$
	4	No Keyway
	$1 \frac{1}{4}$ - $3 \frac{3}{4}$	STD
M	$3 \frac{13}{16}$ - $4 \frac{1}{2}$	$1 \times \frac{1}{8}$
	2 - $4 \frac{3}{4}$	STD
N	$4 \frac{13}{16}$ - $5 \frac{1}{2}$	$1 \frac{1}{4} \times \frac{1}{4}$
	$2 \frac{7}{16}$ - 5	STD
	$5 \frac{7}{8}$ - $5 \frac{1}{2}$	$1 \frac{1}{4} \times \frac{1}{4}$
P	$5 \frac{9}{16}$ - 6	$1 \frac{1}{2} \times \frac{1}{4}$
	$2 \frac{15}{16}$ - $5 \frac{15}{16}$	STD
	6 - $6 \frac{1}{2}$	$1 \frac{1}{2} \times \frac{1}{4}$
W	6 $\frac{9}{16}$ - 7	$1 \frac{3}{4} \times \frac{1}{8}$
	4 - $7 \frac{1}{2}$	STD
	$7 \frac{9}{16}$ - $8 \frac{1}{2}$	$2 \times \frac{1}{4}$

* Important

The metric system does not refer to keyseat or keyway dimensions as does the English system, instead dimensions are given for the key itself which is rectangular in shape, not square as in the English system

Metric bores and keyway

Bushing	Bores	Keyway - WxT (mm)*
SH	24, 25	8 x 7
	28, 30	
	32, 35	10 x 8
SDS	24, 25	8 x 7
	28, 30	
	32, 35	10 x 8
	38	
SD	40, 42	12 x 8
	24, 25	8 x 7
	28, 30	
	32, 35	10 x 8
	38	
SK	40, 42	12 x 8
	24, 25	8 x 7
	28, 30	
	32, 35	10 x 8
	38	
	40, 42	12 x 8
SF	48, 50	14 x 9
	55	16 x 10
	28, 30	8 x 7
	32, 35	10 x 8
	38	
	40, 42	12 x 8
E	48, 50	14 x 9
	55	16 x 10
	60	18 x 11
	35, 38	10 x 8
	40, 42	12 x 8
F	48, 50	14 x 9
	55	16 x 10
	60, 65	18 x 11
	70, 75	20 x 12
	48, 50	14 x 9
J	55	16 x 10
	60, 65	18 x 11
	70, 75	20 x 12
	80, 85	22 x 14
	90	25 x 14
	50	14 x 9
	55	16 x 10
	60, 65	18 x 11
	70, 75	20 x 12
	80, 85	22 x 14
	90, 95	25 x 14
	100	28 x 16

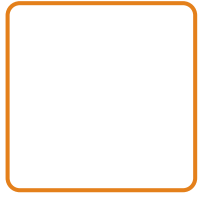

Weld-on hubs

- ▶ Belts
- ▶ Chains
- ▶ Couplings
- ▶ Bushings and Hubs
- ▶ Sprockets
- ▶ Pulleys
- ▶ Smart tools

Type 1

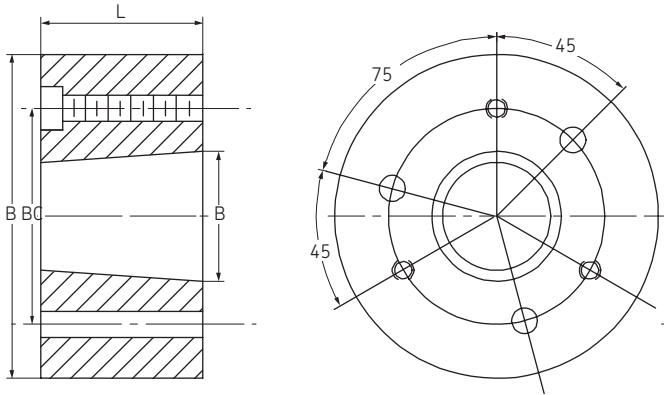

Type 2

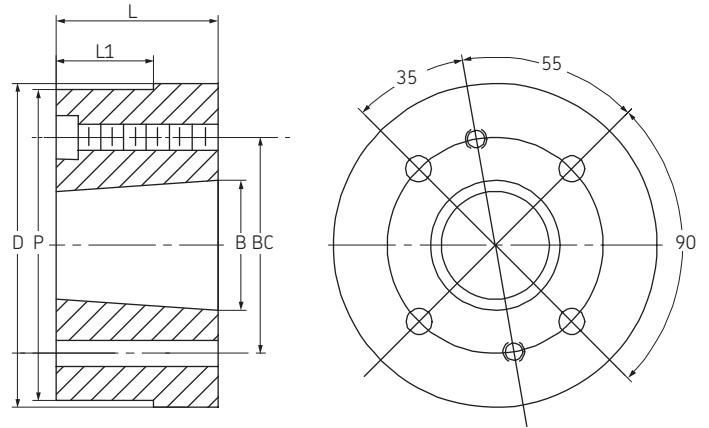

Bushing	Dimensions (mm)						Type drilling	Approx weight (kg)	Mounting	Designation	
	D	L	B	P	L ₁	BC					
JA	57,2	14,3	34,9	-	-	42,1	1	0,18	Std or R1 Ev1 Ers1 E Mount	PHH WJA	
SH	76,2	20,6	47,5	-	-	57,2	1	0,45		PHH WSH	
SDS	88,9	19,1	55,6	-	-	68,3	1	0,57		PHH WSDS	
SK	111,1	31,8	71,5	-	-	84,1	1	1,36		PHH WSK	
SF	127,0	31,8	79,4	-	-	98,4	1	1,81		PHH WSF	
E	158,8	41,3	97,3	-	-	127,0	1	4,08		PHH WE	
F	177,8	63,5	112,7	-	-	142,9	1	7,26		PHH WF	
J	196,9	81,0	130,6	-	-	158,8	1	10,21		PHH WJ	
M	241,3	131,8	164,9	235,0	90,5	200,0	2	22,69		Std Mount only	PHH WM
N	266,7	158,8	177,5	260,4	114,3	215,9	2	34,03			PHH WN
P	330,2	184,2	209,3	-	-	254,0	2	70,33	PHH WP		
W	393,7	228,6	265,1	-	-	323,9	2	136,12	PHH WW		
S	495,3	304,8	308,0	476,3	-	381,0	2	253,18	PHH WS		

Chain Drives Smart Tools V & Wedge belts Pulleys & Sh
Keyless bushings Special belts Chain Drives Smart Tools
Synchronous belts Sprockets Keyless bushings Special
& Sheaves Couplings & U-joints Synchronous belts Spro
Tools V & Wedge belts Pulleys & Sheaves Couplings &
Special belts Chain Drives Smart Tools V & Wedge belts F
Sprockets Keyless bushings Special belts Chain Drives S
& U-joints Synchronous belts Sprockets Keyless bushing
Pulleys & Sheaves Couplings & U-joints Synchronous bel
Smart Tools V & Wedge belts Pulleys & Sheaves Couplings
Special belts Chain Drives Smart Tools V & Wedge belts F
Sprockets Keyless bushings Special belts Chain Drives S
& U-joints Synchronous belts Sprockets Keyless bushing
Pulleys & Sheaves Couplings & U-joints Synchronous bel
Smart Tools V & Wedge belts Pulleys & Sheaves Couplings
Special belts Chain Drives Smart Tools V & Wedge belts F
Sprockets Keyless bushings Special belts Chain Drives S
& U-joints Synchronous belts Sprockets Keyless bushing
Pulleys & Sheaves Couplings & U-joints Synchronous bel
Smart Tools V & Wedge belts Pulleys & Sheaves Couplings
Special belts Chain Drives Smart Tools V & Wedge belts F
Sprockets Keyless bushings Special belts Chain Drives S
& U-joints Synchronous belts Sprockets Keyless bushing
Pulleys & Sheaves Couplings & U-joints Synchronous bel
Smart Tools V & Wedge belts Pulleys & Sheaves Couplings
Special belts Chain Drives Smart Tools V & Wedge belts F
Sprockets Keyless bushings Special belts Chain Drives S
& U-joints Synchronous belts Sprockets Keyless bushing
Pulleys & Sheaves Couplings & U-joints Synchronous

Sprockets





Metric sprockets



Simplex
Pilot bore

ISO 05B-1 8 mm Pitch

Pilot bore Type B

Type A

No. Teeth	Pitch Diameter	Type	Bore		Hub		Weight	Designation	No. Teeth	Pitch Diameter	Type	Bore Stock	Weight	Designation
			Min	Max	H	L								
	mm		mm	mm	mm	mm	kg		mm		mm	kg		
8	20,90	B	6	6	13	12	0,02	PHS 05B-1B8	8	20,90	A	6	0,01	PHS 05B-1A8
9	23,39	B	6	6	15	12	0,02	PHS 05B-1B9	9	23,39	A	6	0,01	PHS 05B-1A9
10	25,89	B	8	8	17	12	0,02	PHS 05B-1B10	10	25,89	A	8	0,01	PHS 05B-1A10
11	28,39	B	8	8	18	13	0,03	PHS 05B-1B11	11	28,39	A	8	0,01	PHS 05B-1A11
12	30,91	B	8	8	20	13	0,03	PHS 05B-1B12	12	30,91	A	8	0,01	PHS 05B-1A12
13	33,42	B	8	8	23	13	0,05	PHS 05B-1B13	13	33,42	A	8	0,01	PHS 05B-1A13
14	35,95	B	8	10	25	13	0,05	PHS 05B-1B14	14	35,95	A	8	0,02	PHS 05B-1A14
15	38,48	B	8	12	28	13	0,07	PHS 05B-1B15	15	38,48	A	8	0,02	PHS 05B-1A15
16	41,01	B	8	14	30	14	0,08	PHS 05B-1B16	16	41,01	A	8	0,02	PHS 05B-1A16
17	43,53	B	8	14	30	14	0,09	PHS 05B-1B17	17	43,53	A	8	0,03	PHS 05B-1A17
18	46,07	B	8	14	30	14	0,09	PHS 05B-1B18	18	46,07	A	8	0,03	PHS 05B-1A18
19	48,61	B	8	14	30	14	0,10	PHS 05B-1B19	19	48,61	A	8	0,03	PHS 05B-1A19
20	51,14	B	8	14	30	14	0,10	PHS 05B-1B20	20	51,14	A	8	0,04	PHS 05B-1A20
21	53,67	B	8	19	35	14	0,13	PHS 05B-1B21	21	53,67	A	8	0,04	PHS 05B-1A21
22	56,21	B	8	19	35	14	0,13	PHS 05B-1B22	22	56,21	A	8	0,05	PHS 05B-1A22
23	58,75	B	8	19	35	14	0,13	PHS 05B-1B23	23	58,75	A	8	0,05	PHS 05B-1A23
24	61,29	B	8	19	35	14	0,15	PHS 05B-1B24	24	61,29	A	8	0,06	PHS 05B-1A24
25	63,83	B	8	19	35	14	0,15	PHS 05B-1B25	25	63,83	A	8	0,06	PHS 05B-1A25
26	66,37	B	10	23	40	16	0,17	PHS 05B-1B26	26	66,37	A	10	0,07	PHS 05B-1A26
27	68,91	B	10	23	40	16	0,19	PHS 05B-1B27	27	68,91	A	10	0,07	PHS 05B-1A27
28	71,45	B	10	23	40	16	0,20	PHS 05B-1B28	28	71,45	A	10	0,08	PHS 05B-1A28
29	73,99	B	10	23	40	16	0,21	PHS 05B-1B29	29	73,99	A	10	0,08	PHS 05B-1A29
30	76,53	B	10	23	40	16	0,22	PHS 05B-1B30	30	76,53	A	10	0,09	PHS 05B-1A30
31	79,08	B	10	23	40	16	0,23	PHS 05B-1B31	31	79,08	A	10	0,10	PHS 05B-1A31
32	81,61	B	10	23	40	16	0,23	PHS 05B-1B32	32	81,61	A	10	0,11	PHS 05B-1A32
33	84,16	B	10	23	40	16	0,24	PHS 05B-1B33	33	84,16	A	10	0,12	PHS 05B-1A33
34	86,70	B	10	23	40	16	0,25	PHS 05B-1B34	34	86,70	A	10	0,12	PHS 05B-1A34
35	89,24	B	10	23	40	16	0,25	PHS 05B-1B35	35	89,24	A	10	0,12	PHS 05B-1A35
36	91,79	B	10	23	40	16	0,26	PHS 05B-1B36	36	91,79	A	10	0,13	PHS 05B-1A36
37	94,33	B	10	23	40	16	0,26	PHS 05B-1B37	37	94,33	A	10	0,14	PHS 05B-1A37
38	96,88	B	10	23	40	16	0,27	PHS 05B-1B38	38	96,88	A	10	0,15	PHS 05B-1A38
39	99,42	B	10	23	40	16	0,28	PHS 05B-1B39	39	99,42	A	10	0,16	PHS 05B-1A39
40	101,97	B	10	23	40	16	0,28	PHS 05B-1B40	40	101,97	A	10	0,16	PHS 05B-1A40
41	104,51	B	10	23	60	20	0,29	PHS 05B-1B41	41	104,51	A	12	0,17	PHS 05B-1A41
42	107,05	B	10	23	60	20	0,30	PHS 05B-1B42	42	107,05	A	12	0,18	PHS 05B-1A42
43	109,60	B	10	23	60	20	0,30	PHS 05B-1B43	43	109,60	A	12	0,19	PHS 05B-1A43
44	112,14	B	10	23	60	20	0,31	PHS 05B-1B44	44	112,14	A	12	0,20	PHS 05B-1A44
45	114,69	B	12	40	60	20	0,31	PHS 05B-1B45	45	114,69	A	12	0,21	PHS 05B-1A45
46	117,23	B	12	40	60	20	0,32	PHS 05B-1B46	46	117,23	A	12	0,21	PHS 05B-1A46
47	119,77	B	12	40	60	20	0,33	PHS 05B-1B47	47	119,77	A	12	0,32	PHS 05B-1A47
48	122,32	B	12	40	60	20	0,33	PHS 05B-1B48	48	122,32	A	12	0,34	PHS 05B-1A48
54	137,59	B	12	40	80	20	0,37	PHS 05B-1B54	54	137,59	A	14	0,67	PHS 05B-1A54
57	145,22	B	14	55	80	20	0,39	PHS 05B-1B57	57	145,22	A	14	1,47	PHS 05B-1A57
60	152,85	B	14	55	80	34	0,41	PHS 05B-1B60	60	152,85	A	14	1,53	PHS 05B-1A60
64	163,04	B	14	55	80	34	0,43	PHS 05B-1B64	64	163,04	A	16	1,62	PHS 05B-1A64
70	178,31	B	14	55	80	34	0,47	PHS 05B-1B70	70	178,31	A	16	1,74	PHS 05B-1A70
72	183,41	B	14	55	80	34	0,48	PHS 05B-1B72	72	183,41	A	20	1,79	PHS 05B-1A72
76	193,59	B	20	55	80	34	0,51	PHS 05B-1B76	76	193,59	A	20	1,87	PHS 05B-1A76
80	203,77	B	20	55	80	34	0,53	PHS 05B-1B80	80	203,77	A	20	1,95	PHS 05B-1A80
84	213,95	B	20	55	80	34	0,56	PHS 05B-1B84	84	213,95	A	20	2,04	PHS 05B-1A84
90	229,23	B	20	55	80	34	0,60	PHS 05B-1B90	90	229,23	A	20	2,16	PHS 05B-1A90
95	241,96	B	20	55	80	34	0,63	PHS 05B-1B95	95	241,96	A	20	2,27	PHS 05B-1A95
96	244,50	B	20	55	80	34	0,63	PHS 05B-1B96	96	244,50	A	20	2,29	PHS 05B-1A96
114	290,33	B	20	55	88	39	0,75	PHS 05B-1B114	114	290,33	A	20	2,67	PHS 05B-1A114

Type A

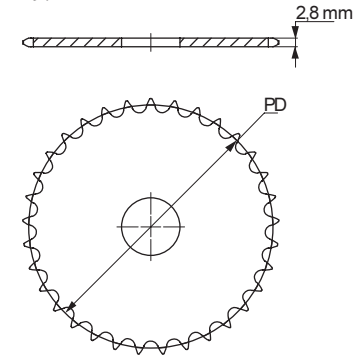

Type B

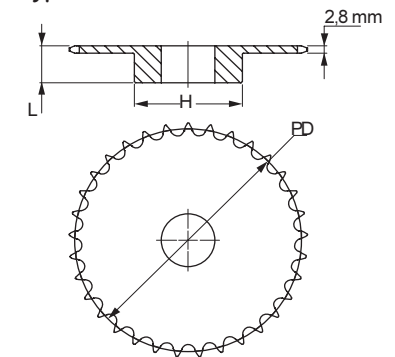

Maximum bores can accommodate standard keyways. Larger bores are available where a shallow keyway is used or no keyway is required.

For hardened teeth sprockets, add "H" after the sprocket profile e.g. PHS 08B-1AH8.



Metric sprockets

Simplex

Pilot bore

- ▶ Belts
- ▶ Chains
- ▶ Couplings
- ▶ Bushings and Hubs
- ▶ Sprockets
- ▶ Pulleys
- ▶ Smart tools

ISO 06B-1 9,525 mm Pitch

Pilot bore Type B

Type A

No. Teeth	Pitch Diameter mm	Type	Bore		Hub		Weight kg	Designation	No. Teeth	Pitch Diameter mm	Type	Bore Stock mm	Weight kg	Designation
			Min mm	Max mm	H mm	L mm								
8	24,89	B	6	6	15+	20	0,03	PHS 06B-1B8	8	24,89	A	6	0,02	PHS 06B-1A8
9	27,85	B	8	8	18+	20	0,04	PHS 06B-1B9	9	27,85	A	8	0,02	PHS 06B-1A9
10	30,82	B	8	8	20	20	0,06	PHS 06B-1B10	10	30,82	A	8	0,02	PHS 06B-1A10
11	33,80	B	8	8	22	25	0,08	PHS 06B-1B11	11	33,80	A	8	0,03	PHS 06B-1A11
12	36,80	B	8	10	25	25	0,10	PHS 06B-1B12	12	36,80	A	8	0,04	PHS 06B-1A12
13	39,79	B	10	12	28	25	0,12	PHS 06B-1B13	13	39,79	A	8	0,05	PHS 06B-1A13
14	42,80	B	10	15	31	25	0,15	PHS 06B-1B14	14	42,80	A	8	0,05	PHS 06B-1A14
15	45,81	B	10	18	34	25	0,19	PHS 06B-1B15	15	45,81	A	8	0,06	PHS 06B-1A15
16	48,82	B	10	20	37	28	0,24	PHS 06B-1B16	16	48,82	A	10	0,07	PHS 06B-1A16
17	51,83	B	10	23	40	28	0,29	PHS 06B-1B17	17	51,83	A	10	0,07	PHS 06B-1A17
18	54,85	B	10	26	43	28	0,33	PHS 06B-1B18	18	54,85	A	10	0,08	PHS 06B-1A18
19	57,87	B	10	28	45	28	0,37	PHS 06B-1B19	19	57,87	A	10	0,09	PHS 06B-1A19
20	60,89	B	10	28	46	28	0,39	PHS 06B-1B20	20	60,89	A	10	0,10	PHS 06B-1A20
21	63,91	B	12	30	48	28	0,42	PHS 06B-1B21	21	63,91	A	10	0,11	PHS 06B-1A21
22	66,93	B	12	35	50	28	0,46	PHS 06B-1B22	22	66,93	A	10	0,13	PHS 06B-1A22
23	69,95	B	12	35	52	28	0,50	PHS 06B-1B23	23	69,95	A	10	0,14	PHS 06B-1A23
24	72,97	B	12	35	54	28	0,54	PHS 06B-1B24	24	72,97	A	10	0,15	PHS 06B-1A24
25	76,00	B	12	40	57	28	0,60	PHS 06B-1B25	25	76,00	A	10	0,17	PHS 06B-1A25
26	79,02	B	12	40	60	28	0,67	PHS 06B-1B26	26	79,02	A	10	0,18	PHS 06B-1A26
27	82,05	B	12	40	60	28	0,68	PHS 06B-1B27	27	82,05	A	10	0,19	PHS 06B-1A27
28	85,07	B	12	40	60	28	0,70	PHS 06B-1B28	28	85,07	A	10	0,21	PHS 06B-1A28
29	88,09	B	12	40	60	28	0,72	PHS 06B-1B29	29	88,09	A	10	0,23	PHS 06B-1A29
30	91,12	B	12	40	60	28	0,77	PHS 06B-1B30	30	91,12	A	10	0,25	PHS 06B-1A30
31	94,15	B	14	43	65	30	0,88	PHS 06B-1B31	31	94,15	A	12	0,26	PHS 06B-1A31
32	97,17	B	14	43	65	30	0,90	PHS 06B-1B32	32	97,17	A	12	0,28	PHS 06B-1A32
33	100,20	B	14	43	65	30	0,91	PHS 06B-1B33	33	100,20	A	12	0,30	PHS 06B-1A33
34	103,23	B	14	43	65	30	0,94	PHS 06B-1B34	34	103,23	A	12	0,32	PHS 06B-1A34
35	106,26	B	14	43	65	30	0,95	PHS 06B-1B35	35	106,26	A	12	0,34	PHS 06B-1A35
36	109,29	B	14	48	70	30	1,07	PHS 06B-1B36	36	109,29	A	12	0,35	PHS 06B-1A36
37	112,32	B	14	48	70	30	1,09	PHS 06B-1B37	37	112,32	A	12	0,38	PHS 06B-1A37
38	115,35	B	14	48	70	30	1,10	PHS 06B-1B38	38	115,35	A	12	0,39	PHS 06B-1A38
39	118,37	B	14	48	70	30	1,12	PHS 06B-1B39	39	118,37	A	12	0,42	PHS 06B-1A39
40	121,40	B	14	48	70	30	1,16	PHS 06B-1B40	40	121,40	A	12	0,44	PHS 06B-1A40
41	124,43	B	14	48	78	32	1,28	PHS 06B-1B41	41	124,43	A	16	0,46	PHS 06B-1A41
42	127,46	B	14	48	78	32	1,36	PHS 06B-1B42	42	127,46	A	16	0,48	PHS 06B-1A42
43	130,49	B	14	48	78	32	1,44	PHS 06B-1B43	43	130,49	A	16	0,51	PHS 06B-1A43
44	133,52	B	14	48	78	32	1,52	PHS 06B-1B44	44	133,52	A	16	0,54	PHS 06B-1A44
45	136,55	B	14	40	78	32	1,40	PHS 06B-1B45	45	136,55	A	16	0,56	PHS 06B-1A45
46	139,58	B	14	48	78	32	1,68	PHS 06B-1B46	46	139,58	A	16	0,59	PHS 06B-1A46
47	142,61	B	14	48	78	32	1,76	PHS 06B-1B47	47	142,61	A	16	0,61	PHS 06B-1A47
48	145,64	B	14	48	78	32	1,84	PHS 06B-1B48	48	145,64	A	16	0,63	PHS 06B-1A48
50	151,69	B	14	48	78	32	2,06	PHS 06B-1B50	50	151,69	A	16	0,65	PHS 06B-1A50
54	163,82	B	14	48	78	32	2,32	PHS 06B-1B54	54	163,82	A	16	0,68	PHS 06B-1A54
57	172,91	B	14	40	78	32	1,70	PHS 06B-1B57	57	172,91	A	16	1,71	PHS 06B-1A57
60	182,00	B	14	48	78	32	2,80	PHS 06B-1B60	60	182,00	A	16	0,91	PHS 06B-1A60
64	194,12	B	14	48	78	32	3,12	PHS 06B-1B64	64	194,12	A	20	0,97	PHS 06B-1A64
65	197,15	B	14	48	78	32	3,31	PHS 06B-1B65	65	197,15	A	20	1,01	PHS 06B-1A65
70	212,30	B	14	48	78	32	3,60	PHS 06B-1B70	70	212,30	A	20	1,06	PHS 06B-1A70
72	218,37	B	14	48	78	32	3,76	PHS 06B-1B72	72	218,37	A	20	1,09	PHS 06B-1A72
76	230,49	B	14	48	78	32	2,79	PHS 06B-1B76	76	230,49	A	20	1,64	PHS 06B-1A76
80	242,61	B	14	52	78	32	4,40	PHS 06B-1B80	80	242,61	A	20	1,53	PHS 06B-1A80
84	254,74	B	14	52	80	32	4,72	PHS 06B-1B84	84	254,74	A	20	1,60	PHS 06B-1A84
85	257,77	B	14	52	80	32	4,93	PHS 06B-1B85	85	257,77	A	20	1,66	PHS 06B-1A85
90	272,93	B	14	55	80	32	5,20	PHS 06B-1B90	90	272,93	A	20	1,72	PHS 06B-1A90
92	278,99	B	14	55	80	32	5,45	PHS 06B-1B92	92	278,99	A	20	2,16	PHS 06B-1A92
95	288,08	B	14	55	80	32	3,95	PHS 06B-1B95	95	288,08	A	20	2,60	PHS 06B-1A95
96	291,11	B	14	55	80	32	5,68	PHS 06B-1B96	96	291,11	A	20	2,20	PHS 06B-1A96
114	345,68	B	14	55	80	32	7,12	PHS 06B-1B114	114	345,68	A	20	3,13	PHS 06B-1A114

Maximum bores can accommodate standard keyways. Larger bores are available where a shallow keyway is used or no keyway is required.

For hardened teeth sprockets, add "H" after the sprocket profile e.g. PHS 08B-1AH8.

Type A

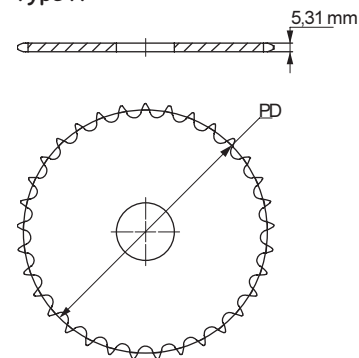

Type B

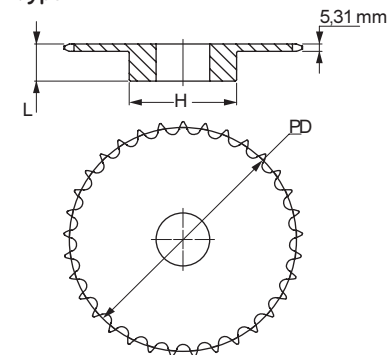

Metric sprockets



Simplex
Pilot bore

ISO 08B-1 12,70 mm Pitch

Pilot bore Type B

Type A

No. Teeth	Pitch Diameter	Type	Bore		Hub		Weight	Designation	No. Teeth	Pitch Diameter	Type	Bore Stock	Weight	Designation
			Min	Max	H	L								
	mm		mm	mm	mm	mm	kg		mm		mm	kg		
8	33,18	B	10	10	20	25	0,06	PHS 08B-1B8	8	33,18	A	8	0,03	PHS 08B-1A8
9	37,13	B	10	10	24	25	0,09	PHS 08B-1B9	9	37,13	A	8	0,04	PHS 08B-1A9
10	41,10	B	10	11	26	25	0,12	PHS 08B-1B10	10	41,10	A	8	0,06	PHS 08B-1A10
11	45,07	B	10	13	29	25	0,15	PHS 08B-1B11	11	45,07	A	10	0,07	PHS 08B-1A11
12	49,07	B	10	17	33	28	0,21	PHS 08B-1B12	12	49,07	A	10	0,09	PHS 08B-1A12
13	53,06	B	10	20	37	28	0,27	PHS 08B-1B13	13	53,06	A	10	0,10	PHS 08B-1A13
14	57,07	B	10	24	41	28	0,33	PHS 08B-1B14	14	57,07	A	10	0,12	PHS 08B-1A14
15	61,09	B	10	28	45	28	0,39	PHS 08B-1B15	15	61,09	A	10	0,13	PHS 08B-1A15
16	65,10	B	12	30	50	28	0,46	PHS 08B-1B16	16	65,10	A	10	0,16	PHS 08B-1A16
17	69,11	B	12	30	52	28	0,51	PHS 08B-1B17	17	69,11	A	10	0,18	PHS 08B-1A17
18	73,14	B	12	35	56	28	0,59	PHS 08B-1B18	18	73,14	A	10	0,20	PHS 08B-1A18
19	77,16	B	12	40	60	28	0,67	PHS 08B-1B19	19	77,16	A	10	0,23	PHS 08B-1A19
20	81,19	B	12	40	64	28	0,77	PHS 08B-1B20	20	81,19	A	10	0,25	PHS 08B-1A20
21	85,22	B	12	40	68	28	0,85	PHS 08B-1B21	21	85,22	A	12	0,26	PHS 08B-1A21
22	89,24	B	12	40	70	28	0,92	PHS 08B-1B22	22	89,24	A	12	0,30	PHS 08B-1A22
23	93,27	B	14	40	70	28	0,95	PHS 08B-1B23	23	93,27	A	12	0,34	PHS 08B-1A23
24	97,29	B	14	40	70	28	0,98	PHS 08B-1B24	24	97,29	A	12	0,37	PHS 08B-1A24
25	101,33	B	14	40	70	28	1,01	PHS 08B-1B25	25	101,33	A	12	0,41	PHS 08B-1A25
26	105,36	B	16	46	70	30	1,09	PHS 08B-1B26	26	105,36	A	16	0,44	PHS 08B-1A26
27	109,40	B	16	46	70	30	1,13	PHS 08B-1B27	27	109,40	A	16	0,48	PHS 08B-1A27
28	113,42	B	16	46	70	30	1,17	PHS 08B-1B28	28	113,42	A	16	0,51	PHS 08B-1A28
29	117,46	B	16	46	80	30	1,41	PHS 08B-1B29	29	117,46	A	16	0,55	PHS 08B-1A29
30	121,50	B	16	46	80	30	1,46	PHS 08B-1B30	30	121,50	A	16	0,59	PHS 08B-1A30
31	125,54	B	16	46	90	30	1,75	PHS 08B-1B31	31	125,54	A	16	0,63	PHS 08B-1A31
32	129,56	B	16	46	90	30	1,79	PHS 08B-1B32	32	129,56	A	16	0,68	PHS 08B-1A32
33	133,60	B	16	46	90	30	1,83	PHS 08B-1B33	33	133,60	A	16	0,72	PHS 08B-1A33
34	137,64	B	16	46	90	30	1,87	PHS 08B-1B34	34	137,64	A	16	0,78	PHS 08B-1A34
35	141,68	B	16	46	90	30	1,94	PHS 08B-1B35	35	141,68	A	16	0,81	PHS 08B-1A35
36	145,72	B	16	50	90	35	2,21	PHS 08B-1B36	36	145,72	A	16	0,87	PHS 08B-1A36
37	149,76	B	16	50	90	35	2,24	PHS 08B-1B37	37	149,76	A	16	0,92	PHS 08B-1A37
38	153,80	B	16	50	90	35	2,33	PHS 08B-1B38	38	153,80	A	16	0,97	PHS 08B-1A38
39	157,83	B	16	50	90	35	2,30	PHS 08B-1B39	39	157,83	A	16	1,02	PHS 08B-1A39
40	161,87	B	16	50	90	35	2,44	PHS 08B-1B40	40	161,87	A	16	1,08	PHS 08B-1A40
41	165,91	B	16	50	90	40	2,41	PHS 08B-1B41	41	165,91	A	20	1,10	PHS 08B-1A41
42	169,95	B	16	60	90	40	2,38	PHS 08B-1B42	42	169,95	A	20	1,00	PHS 08B-1A42
43	173,99	B	16	50	90	40	2,35	PHS 08B-1B43	43	173,99	A	20	1,24	PHS 08B-1A43
44	178,03	B	16	50	90	40	2,32	PHS 08B-1B44	44	178,03	A	20	1,28	PHS 08B-1A44
45	182,07	B	16	50	90	40	2,30	PHS 08B-1B45	45	182,07	A	20	1,00	PHS 08B-1A45
46	186,10	B	16	50	90	40	2,45	PHS 08B-1B46	46	186,10	A	20	1,43	PHS 08B-1A46
47	190,14	B	16	50	90	40	2,60	PHS 08B-1B47	47	190,14	A	20	1,50	PHS 08B-1A47
48	194,18	B	16	64	90	40	2,85	PHS 08B-1B48	48	194,18	A	20	1,57	PHS 08B-1A48
50	208,30	B	16	64	90	40	2,92	PHS 08B-1B50	50	208,30	A	20	1,81	PHS 08B-1A50
54	218,43	B	16	64	90	40	3,00	PHS 08B-1B54	54	218,43	A	20	2,00	PHS 08B-1A54
57	230,54	B	16	50	90	40	3,13	PHS 08B-1B57	57	230,54	A	20	2,22	PHS 08B-1A57
60	242,66	B	16	64	90	40	3,30	PHS 08B-1B60	60	242,66	A	20	2,50	PHS 08B-1A60
64	258,82	B	16	64	90	40	3,60	PHS 08B-1B64	64	258,82	A	25	2,87	PHS 08B-1A64
70	283,07	B	16	64	90	40	3,80	PHS 08B-1B70	70	283,07	A	25	3,43	PHS 08B-1A70
72	291,16	B	16	64	90	40	4,00	PHS 08B-1B72	72	291,16	A	25	3,62	PHS 08B-1A72
76	307,33	B	16	50	90	40	4,12	PHS 08B-1B76	76	307,33	A	25	3,99	PHS 08B-1A76
80	323,48	B	16	64	90	40	5,00	PHS 08B-1B80	80	323,48	A	25	4,46	PHS 08B-1A80
84	339,65	B	16	64	90	40	6,12	PHS 08B-1B84	84	339,65	A	25	4,93	PHS 08B-1A84
85	343,69	B	16	64	90	40	6,32	PHS 08B-1B85	85	343,69	A	25	5,05	PHS 08B-1A85
92	371,99	B	16	64	90	40	6,92	PHS 08B-1B92	92	371,99	A	25	5,88	PHS 08B-1A92
95	384,11	B	16	55	90	40	7,38	PHS 08B-1B95	95	384,11	A	25	6,23	PHS 08B-1A95
96	388,15	B	16	64	90	40	8,00	PHS 08B-1B96	96	388,15	A	25	6,35	PHS 08B-1A96
114	460,90	B	16	64	90	40	9,50	PHS 08B-1B114	114	460,90	A	25	8,47	PHS 08B-1A114

Type A

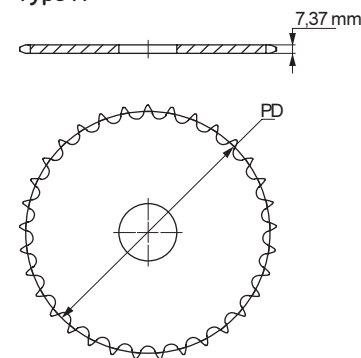

Type B

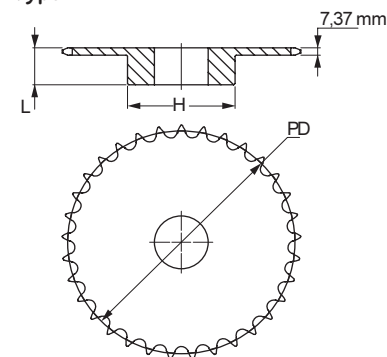

Maximum bores can accommodate standard keyways. Larger bores are available where a shallow keyway is used or no keyway is required.

For hardened teeth sprockets, add "H" after the sprocket profile e.g. PHS 08B-1AH8.



Metric sprockets

Simplex

Pilot bore

- ▶ Belts
- ▶ Chains
- ▶ Couplings
- ▶ Bushings and Hubs
- ▶ Sprockets
- ▶ Pulleys
- ▶ Smart tools

ISO 10B-1 15,88 mm Pitch

Pilot bore Type B

Type A

No. Teeth	Pitch Diameter	Type	Bore		Hub		Weight	Designation	No. Teeth	Pitch Diameter	Type	Bore Stock	Weight	Designation
			Min	Max	H	L								
8	41,48	B	10	11	25	25	0,12	PHS 10B-1B8	8	41,48	A	10	0,07	PHS 10B-1A8
9	46,42	B	10	15	30	25	0,17	PHS 10B-1B9	9	46,42	A	10	0,10	PHS 10B-1A9
10	51,37	B	10	18	35	25	0,23	PHS 10B-1B10	10	51,37	A	10	0,12	PHS 10B-1A10
11	56,34	B	12	21	37	30	0,30	PHS 10B-1B11	11	56,34	A	10	0,15	PHS 10B-1A11
12	61,34	B	12	25	42	30	0,38	PHS 10B-1B12	12	61,34	A	10	0,18	PHS 10B-1A12
13	66,32	B	12	28	47	30	0,47	PHS 10B-1B13	13	66,32	A	10	0,21	PHS 10B-1A13
14	71,34	B	12	32	52	30	0,57	PHS 10B-1B14	14	71,34	A	10	0,24	PHS 10B-1A14
15	76,36	B	12	35	57	30	0,69	PHS 10B-1B15	15	76,36	A	10	0,28	PHS 10B-1A15
16	81,37	B	12	40	60	30	0,77	PHS 10B-1B16	16	81,37	A	12	0,31	PHS 10B-1A16
17	86,39	B	12	40	60	30	0,82	PHS 10B-1B17	17	86,39	A	12	0,36	PHS 10B-1A17
18	91,42	B	14	50	70	30	1,02	PHS 10B-1B18	18	91,42	A	12	0,41	PHS 10B-1A18
19	96,45	B	14	50	70	30	1,06	PHS 10B-1B19	19	96,45	A	12	0,46	PHS 10B-1A19
20	101,49	B	14	50	75	30	1,22	PHS 10B-1B20	20	101,49	A	12	0,52	PHS 10B-1A20
21	106,52	B	16	50	75	30	1,26	PHS 10B-1B21	21	106,52	A	12	0,57	PHS 10B-1A21
22	111,55	B	16	50	80	30	1,42	PHS 10B-1B22	22	111,55	A	12	0,62	PHS 10B-1A22
23	116,58	B	16	50	80	30	1,47	PHS 10B-1B23	23	116,58	A	12	0,67	PHS 10B-1A23
24	121,62	B	16	50	80	30	1,55	PHS 10B-1B24	24	121,62	A	12	0,74	PHS 10B-1A24
25	126,66	B	16	50	80	30	1,62	PHS 10B-1B25	25	126,66	A	12	0,81	PHS 10B-1A25
26	131,70	B	20	55	85	35	2,00	PHS 10B-1B26	26	131,70	A	16	0,88	PHS 10B-1A26
27	136,75	B	20	55	85	35	2,05	PHS 10B-1B27	27	136,75	A	16	0,96	PHS 10B-1A27
28	141,78	B	20	55	90	35	2,27	PHS 10B-1B28	28	141,78	A	16	1,02	PHS 10B-1A28
29	146,83	B	20	55	90	35	2,35	PHS 10B-1B29	29	146,83	A	16	1,09	PHS 10B-1A29
30	151,87	B	20	58	90	35	2,42	PHS 10B-1B30	30	151,87	A	16	1,20	PHS 10B-1A30
31	156,92	B	20	58	95	35	2,66	PHS 10B-1B31	31	156,92	A	16	1,28	PHS 10B-1A31
32	161,95	B	20	58	95	35	2,74	PHS 10B-1B32	32	161,95	A	16	1,38	PHS 10B-1A32
33	167,00	B	20	58	95	35	2,80	PHS 10B-1B33	33	167,00	A	16	1,46	PHS 10B-1A33
34	172,05	B	20	58	95	35	2,90	PHS 10B-1B34	34	172,05	A	16	1,55	PHS 10B-1A34
35	177,10	B	20	58	95	35	3,03	PHS 10B-1B35	35	177,10	A	16	1,63	PHS 10B-1A35
36	182,15	B	20	63	100	35	3,27	PHS 10B-1B36	36	182,15	A	20	2,00	PHS 10B-1A36
37	187,20	B	20	63	100	35	3,39	PHS 10B-1B37	37	187,20	A	20	1,85	PHS 10B-1A37
38	192,24	B	20	63	100	35	3,49	PHS 10B-1B38	38	192,24	A	20	1,93	PHS 10B-1A38
39	197,29	B	20	63	100	35	3,58	PHS 10B-1B39	39	197,29	A	20	2,05	PHS 10B-1A39
40	202,34	B	20	63	100	35	3,69	PHS 10B-1B40	40	202,34	A	20	2,15	PHS 10B-1A40
41	207,39	B	20	57	100	40	3,78	PHS 10B-1B41	41	207,39	A	20	2,25	PHS 10B-1A41
42	212,44	B	20	57	100	40	3,87	PHS 10B-1B42	42	212,44	A	20	2,38	PHS 10B-1A42
43	217,49	B	20	57	100	40	3,96	PHS 10B-1B43	43	217,49	A	20	2,49	PHS 10B-1A43
44	222,53	B	20	57	100	40	4,05	PHS 10B-1B44	44	222,53	A	20	2,61	PHS 10B-1A44
45	227,58	B	20	55	100	40	4,18	PHS 10B-1B45	45	227,58	A	20	2,74	PHS 10B-1A45
46	232,63	B	20	64	100	40	4,34	PHS 10B-1B46	46	232,63	A	20	2,87	PHS 10B-1A46
47	237,68	B	20	64	100	40	4,50	PHS 10B-1B47	47	237,68	A	20	2,99	PHS 10B-1A47
48	242,73	B	20	64	100	40	4,66	PHS 10B-1B48	48	242,73	A	20	3,13	PHS 10B-1A48
49	247,78	B	20	64	100	40	4,82	PHS 10B-1B49	49	247,78	A	20	3,28	PHS 10B-1A49
50	252,82	B	20	64	100	40	4,98	PHS 10B-1B50	50	252,82	A	20	3,43	PHS 10B-1A50
51	257,87	B	20	64	100	40	5,14	PHS 10B-1B51	51	257,87	A	20	3,57	PHS 10B-1A51
52	262,92	B	20	64	100	40	5,30	PHS 10B-1B52	52	262,92	A	20	3,72	PHS 10B-1A52
53	267,97	B	20	64	100	40	5,46	PHS 10B-1B53	53	267,97	A	20	3,87	PHS 10B-1A53
54	273,03	B	20	64	100	40	5,62	PHS 10B-1B54	54	273,03	A	20	4,02	PHS 10B-1A54
55	278,08	B	20	64	100	40	5,78	PHS 10B-1B55	55	278,08	A	20	4,16	PHS 10B-1A55
56	283,13	B	20	64	100	40	5,94	PHS 10B-1B56	56	283,13	A	25	4,31	PHS 10B-1A56
57	288,18	B	20	55	100	40	6,00	PHS 10B-1B57	57	288,18	A	25	4,46	PHS 10B-1A57
58	293,23	B	20	64	100	43	6,44	PHS 10B-1B58	58	293,23	A	25	4,64	PHS 10B-1A58
59	298,27	B	20	64	100	43	6,88	PHS 10B-1B59	59	298,27	A	25	4,83	PHS 10B-1A59
60	303,32	B	20	64	100	43	7,32	PHS 10B-1B60	60	303,32	A	25	5,01	PHS 10B-1A60
65	328,58	B	20	64	100	43	7,48	PHS 10B-1B65	65	328,58	A	25	5,92	PHS 10B-1A65
70	353,84	B	20	64	100	43	7,76	PHS 10B-1B70	70	353,84	A	25	6,83	PHS 10B-1A70
72	363,95	B	20	64	100	43	8,20	PHS 10B-1B72	72	363,95	A	25	7,20	PHS 10B-1A72
76	384,16	B	20	60	100	43	8,68	PHS 10B-1B76	76	384,16	A	25	7,93	PHS 10B-1A76
80	404,35	B	20	70	100	43	10,20	PHS 10B-1B80	80	404,35	A	25	8,89	PHS 10B-1A80
84	424,57	B	20	70	100	50	11,72	PHS 10B-1B84	84	424,57	A	30	9,85	PHS 10B-1A84
85	429,62	B	20	70	100	50	12,12	PHS 10B-1B85	85	429,62	A	30	10,09	PHS 10B-1A85
92	464,98	B	20	70	100	50	12,91	PHS 10B-1B92	92	464,98	A	30	11,76	PHS 10B-1A92
95	480,14	B	20	60	100	50	13,24	PHS 10B-1B95	95	480,14	A	30	12,48	PHS 10B-1A95
96	485,19	B	20	70	100	50	14,00	PHS 10B-1B96	96	485,19	A	30	12,72	PHS 10B-1A96
112	566,03	B	20	70	100	50	15,55	PHS 10B-1B112	112	566,03	A	30	16,55	PHS 10B-1A112
114	576,13	B	20	70	100	50	16,25	PHS 10B-1B114	114	576,13	A	30	17,03	PHS 10B-1A114
120	606,45	B	20	70	100	50	18,25	PHS 10B-1B120	120	606,45	A	30	18,50	PHS 10B-1A120

Type A

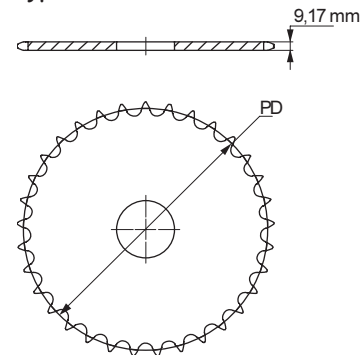

Type B

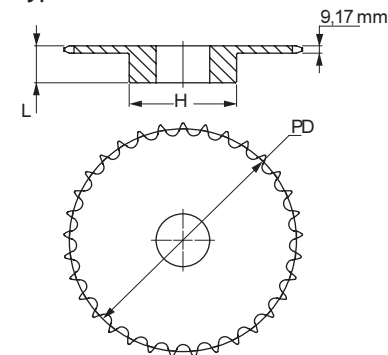

Maximum bores can accommodate standard keyways. Larger bores are available where a shallow keyway is used or no keyway is required.

For hardened teeth sprockets, add "H" after the sprocket profile e.g. PHS 08B-1AH8.

Metric sprockets



Simplex
Pilot bore

ISO 12B-1 19,05 mm Pitch

Pilot bore Type B

Type A

No. Teeth	Pitch Diameter	Type	Bore		Hub		Weight	Designation	No. Teeth	Pitch Diameter	Type	Bore Stock	Weight	Designation
			Min	Max	H	L								
	mm		mm	mm	mm	mm	kg		mm		mm	kg		
8	49,78	B	12	16	31	30	0,22	PHS 12B-1B8	8	49,78	A	12	0,13	PHS 12B-1A8
9	55,70	B	12	20	37	30	0,31	PHS 12B-1B9	9	55,70	A	12	0,16	PHS 12B-1A9
10	61,64	B	12	23	42	30	0,39	PHS 12B-1B10	10	61,64	A	12	0,21	PHS 12B-1A10
11	67,61	B	14	28	46	35	0,54	PHS 12B-1B11	11	67,61	A	14	0,25	PHS 12B-1A11
12	73,61	B	14	32	52	35	0,68	PHS 12B-1B12	12	73,61	A	14	0,30	PHS 12B-1A12
13	79,59	B	14	36	58	35	0,84	PHS 12B-1B13	13	79,59	A	14	0,37	PHS 12B-1A13
14	85,61	B	14	40	64	35	1,01	PHS 12B-1B14	14	85,61	A	14	0,43	PHS 12B-1A14
15	91,63	B	14	44	70	35	1,19	PHS 12B-1B15	15	91,63	A	14	0,50	PHS 12B-1A15
16	97,65	B	16	48	75	35	1,36	PHS 12B-1B16	16	97,65	A	14	0,56	PHS 12B-1A16
17	103,67	B	16	55	80	35	1,56	PHS 12B-1B17	17	103,67	A	14	0,65	PHS 12B-1A17
18	109,71	B	16	55	80	35	1,73	PHS 12B-1B18	18	109,71	A	14	0,73	PHS 12B-1A18
19	115,75	B	16	55	80	35	1,73	PHS 12B-1B19	19	115,75	A	14	0,82	PHS 12B-1A19
20	121,78	B	16	55	80	35	1,83	PHS 12B-1B20	20	121,78	A	14	0,90	PHS 12B-1A20
21	127,82	B	20	55	90	40	2,37	PHS 12B-1B21	21	127,82	A	16	0,99	PHS 12B-1A21
22	133,86	B	20	55	90	40	2,48	PHS 12B-1B22	22	133,86	A	16	1,08	PHS 12B-1A22
23	139,90	B	20	55	90	40	2,58	PHS 12B-1B23	23	139,90	A	16	1,21	PHS 12B-1A23
24	145,94	B	20	55	90	40	2,70	PHS 12B-1B24	24	145,94	A	16	1,33	PHS 12B-1A24
25	152,00	B	20	55	90	40	2,81	PHS 12B-1B25	25	152,00	A	16	1,43	PHS 12B-1A25
26	158,04	B	20	58	95	40	3,11	PHS 12B-1B26	26	158,04	A	16	1,57	PHS 12B-1A26
27	164,09	B	20	58	95	40	3,24	PHS 12B-1B27	27	164,09	A	16	1,69	PHS 12B-1A27
28	170,13	B	20	58	95	40	3,37	PHS 12B-1B28	28	170,13	A	16	1,83	PHS 12B-1A28
29	176,19	B	20	60	95	40	3,49	PHS 12B-1B29	29	176,19	A	16	1,97	PHS 12B-1A29
30	182,25	B	20	60	95	40	3,66	PHS 12B-1B30	30	182,25	A	16	2,11	PHS 12B-1A30
31	188,31	B	20	64	95	40	3,96	PHS 12B-1B31	31	188,31	A	20	2,26	PHS 12B-1A31
32	194,36	B	20	64	95	40	4,14	PHS 12B-1B32	32	194,36	A	20	2,37	PHS 12B-1A32
33	200,40	B	20	64	95	40	4,28	PHS 12B-1B33	33	200,40	A	20	2,58	PHS 12B-1A33
34	206,46	B	20	64	95	40	4,45	PHS 12B-1B34	34	206,46	A	20	2,72	PHS 12B-1A34
35	212,52	B	20	64	95	40	4,62	PHS 12B-1B35	35	212,52	A	20	2,90	PHS 12B-1A35
36	218,58	B	20	70	100	40	4,79	PHS 12B-1B36	36	218,58	A	20	3,04	PHS 12B-1A36
37	224,64	B	20	70	100	40	4,97	PHS 12B-1B37	37	224,64	A	20	3,27	PHS 12B-1A37
38	230,69	B	20	70	100	40	5,15	PHS 12B-1B38	38	230,69	A	20	3,42	PHS 12B-1A38
39	236,75	B	20	70	100	40	5,34	PHS 12B-1B39	39	236,75	A	20	3,61	PHS 12B-1A39
40	242,81	B	20	70	100	40	5,54	PHS 12B-1B40	40	242,81	A	20	3,80	PHS 12B-1A40
41	248,87	B	20	70	110	56	5,78	PHS 12B-1B41	41	248,87	A	25	3,97	PHS 12B-1A41
42	254,93	B	20	70	110	56	6,02	PHS 12B-1B42	42	254,93	A	25	4,18	PHS 12B-1A42
43	260,98	B	20	70	110	56	6,26	PHS 12B-1B43	43	260,98	A	25	4,43	PHS 12B-1A43
44	267,04	B	20	70	110	56	6,50	PHS 12B-1B44	44	267,04	A	25	4,60	PHS 12B-1A44
45	273,10	B	20	60	110	56	6,30	PHS 12B-1B45	45	273,10	A	25	4,77	PHS 12B-1A45
46	279,16	B	20	70	110	56	6,98	PHS 12B-1B46	46	279,16	A	25	5,07	PHS 12B-1A46
47	285,21	B	20	70	110	56	7,22	PHS 12B-1B47	47	285,21	A	25	5,30	PHS 12B-1A47
48	291,27	B	20	70	110	56	7,46	PHS 12B-1B48	48	291,27	A	25	5,55	PHS 12B-1A48
49	297,33	B	20	70	110	56	7,70	PHS 12B-1B49	49	297,33	A	25	5,81	PHS 12B-1A49
50	303,39	B	20	70	110	56	7,94	PHS 12B-1B50	50	303,39	A	25	6,06	PHS 12B-1A50
54	327,64	B	20	70	110	56	8,90	PHS 12B-1B54	54	327,64	A	25	7,08	PHS 12B-1A54
57	345,81	B	20	60	110	56	7,75	PHS 12B-1B57	57	345,81	A	25	7,84	PHS 12B-1A57
60	363,99	B	20	70	110	56	10,34	PHS 12B-1B60	60	363,99	A	25	8,82	PHS 12B-1A60
65	394,29	B	20	70	110	56	11,64	PHS 12B-1B65	65	394,29	A	25	10,46	PHS 12B-1A65
68	412,49	B	20	70	110	56	12,20	PHS 12B-1B68	68	412,49	A	30	11,44	PHS 12B-1A68
70	424,60	B	20	70	110	56	12,74	PHS 12B-1B70	70	424,60	A	30	12,10	PHS 12B-1A70
72	436,74	B	20	80	110	56	13,22	PHS 12B-1B72	72	436,74	A	30	12,75	PHS 12B-1A72
76	460,99	B	20	60	110	56	12,50	PHS 12B-1B76	76	460,99	A	30	14,06	PHS 12B-1A76
80	485,22	B	20	80	110	56	15,14	PHS 12B-1B80	80	485,22	A	30	15,73	PHS 12B-1A80
84	509,48	B	20	80	110	56	16,10	PHS 12B-1B84	84	509,48	A	30	17,40	PHS 12B-1A84
90	545,85	B	20	80	110	56	17,23	PHS 12B-1B90	90	545,85	A	30	19,91	PHS 12B-1A90
92	557,98	B	20	80	110	56	18,19	PHS 12B-1B92	92	557,98	A	30	20,75	PHS 12B-1A92
95	576,17	B	20	92	110	56	18,74	PHS 12B-1B95	95	576,17	A	30	22,00	PHS 12B-1A95
96	582,23	B	20	92	110	56	18,98	PHS 12B-1B96	96	582,23	A	30	22,42	PHS 12B-1A96
114	691,36	B	20	92	110	56	23,30	PHS 12B-1B114	114	691,36	A	30	29,94	PHS 12B-1A114

Type A

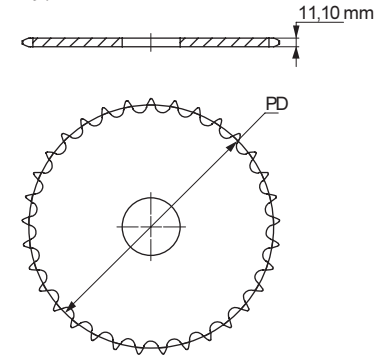

Type B

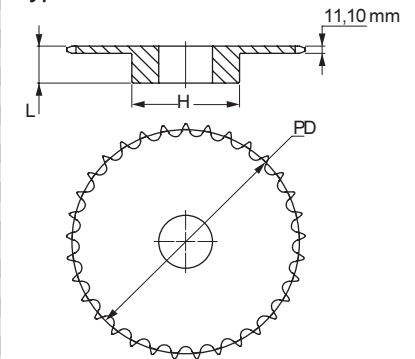

Maximum bores can accommodate standard keyways. Larger bores are available where a shallow keyway is used or no keyway is required.

For hardened teeth sprockets, add "H" after the sprocket profile e.g. PHS 08B-1AH8.



Metric sprockets

Simplex

Pilot bore

- ▶ Belts
- ▶ Chains
- ▶ Couplings
- ▶ Bushings and Hubs
- ▶ Sprockets
- ▶ Pulleys
- ▶ Smart tools

ISO 16B-1 25,40 mm Pitch

Pilot bore Type B/C

Type A

No. Teeth	Pitch Diameter	Type	Bore		Hub		Weight	Designation	No. Teeth	Pitch Diameter	Type	Bore Stock	Weight	Designation
			Min	Max	H	L								
8	66,37	B	16	22	42	35	0,50	PHS 16B-1B8	8	66,37	A	12	0,34	PHS 16B-1A8
9	74,27	B	16	28	50	35	0,68	PHS 16B-1B9	9	74,27	A	12	0,44	PHS 16B-1A9
10	82,19	B	16	34	55	35	0,87	PHS 16B-1B10	10	82,19	A	12	0,96	PHS 16B-1A10
11	90,14	B	16	38	61	40	1,18	PHS 16B-1B11	11	90,14	A	16	0,68	PHS 16B-1A11
12	98,14	B	16	44	69	40	1,48	PHS 16B-1B12	12	98,14	A	16	0,81	PHS 16B-1A12
13	106,12	B	16	48	78	40	1,82	PHS 16B-1B13	13	106,12	A	16	1,00	PHS 16B-1A13
14	114,15	B	16	53	84	40	2,14	PHS 16B-1B14	14	114,15	A	16	1,13	PHS 16B-1A14
15	122,17	B	16	58	92	40	2,52	PHS 16B-1B15	15	122,17	A	16	1,30	PHS 16B-1A15
16	130,20	B	20	64	100	45	3,19	PHS 16B-1B16	16	130,20	A	20	1,49	PHS 16B-1A16
17	138,22	B	20	70	100	45	3,41	PHS 16B-1B17	17	138,22	A	20	1,68	PHS 16B-1A17
18	146,28	B	20	70	100	45	3,62	PHS 16B-1B18	18	146,28	A	20	1,91	PHS 16B-1A18
19	154,33	B	20	70	100	45	3,86	PHS 16B-1B19	19	154,33	A	20	2,12	PHS 16B-1A19
20	162,38	B	20	70	100	45	4,10	PHS 16B-1B20	20	162,38	A	20	2,39	PHS 16B-1A20
21	170,43	B	20	70	110	50	5,09	PHS 16B-1B21	21	170,43	A	20	2,64	PHS 16B-1A21
22	178,48	B	20	70	110	50	5,35	PHS 16B-1B22	22	178,48	A	20	2,91	PHS 16B-1A22
23	186,53	B	20	70	110	50	5,66	PHS 16B-1B23	23	186,53	A	20	3,16	PHS 16B-1A23
24	194,59	B	20	70	110	50	5,94	PHS 16B-1B24	24	194,59	A	20	3,43	PHS 16B-1A24
25	202,66	B	20	70	110	50	6,25	PHS 16B-1B25	25	202,66	A	20	3,72	PHS 16B-1A25
26	210,72	B	20	76	120	50	7,07	PHS 16B-1B26	26	210,72	A	20	4,08	PHS 16B-1A26
27	218,79	B	20	76	120	50	7,39	PHS 16B-1B27	27	218,79	A	20	4,40	PHS 16B-1A27
28	226,85	B	20	76	120	50	7,72	PHS 16B-1B28	28	226,85	A	20	4,79	PHS 16B-1A28
29	234,92	B	20	76	120	50	8,11	PHS 16B-1B29	29	234,92	A	20	5,14	PHS 16B-1A29
30	243,00	B	20	76	120	50	8,47	PHS 16B-1B30	30	243,00	A	20	5,53	PHS 16B-1A30
31	251,08	B	25	76	120	50	8,78	PHS 16B-1B31	31	251,08	A	25	5,89	PHS 16B-1A31
32	259,13	B	25	76	120	50	9,19	PHS 16B-1B32	32	259,13	A	25	6,33	PHS 16B-1A32
33	267,21	B	25	76	120	50	9,63	PHS 16B-1B33	33	267,21	A	25	6,70	PHS 16B-1A33
34	275,28	B	25	76	120	50	10,02	PHS 16B-1B34	34	275,28	A	25	7,00	PHS 16B-1A34
35	283,36	B	25	76	120	50	10,50	PHS 16B-1B35	35	283,36	A	25	7,60	PHS 16B-1A35
36	291,44	B	25	76	120	50	10,90	PHS 16B-1B36	36	291,44	A	25	8,08	PHS 16B-1A36
37	299,51	B	25	76	120	50	11,30	PHS 16B-1B37	37	299,51	A	25	8,50	PHS 16B-1A37
38	307,59	B	25	76	120	50	11,86	PHS 16B-1B38	38	307,59	A	25	8,98	PHS 16B-1A38
39	315,67	B	25	76	120	50	12,32	PHS 16B-1B39	39	315,67	A	25	9,34	PHS 16B-1A39
40	323,75	B	25	76	125	50	12,86	PHS 16B-1B40	40	323,75	A	25	9,94	PHS 16B-1A40
41	331,82	B	25	80	125	68	13,40	PHS 16B-1B41	41	331,82	A	25	10,50	PHS 16B-1A41
42	339,90	B	25	80	125	68	13,94	PHS 16B-1B42	42	339,90	A	25	11,02	PHS 16B-1A42
43	347,98	B	25	80	125	68	14,48	PHS 16B-1B43	43	347,98	A	25	11,64	PHS 16B-1A43
44	356,06	B	25	80	125	68	15,02	PHS 16B-1B44	44	356,06	A	25	12,08	PHS 16B-1A44
45	364,13	B	25	80	125	68	15,50	PHS 16B-1B45	45	364,13	A	25	12,60	PHS 16B-1A45
46	372,21	B	25	80	125	68	16,10	PHS 16B-1B46	46	372,21	A	25	13,20	PHS 16B-1A46
47	380,29	B	25	80	125	68	16,64	PHS 16B-1B47	47	380,29	A	25	13,94	PHS 16B-1A47
48	388,36	B	25	80	125	68	17,18	PHS 16B-1B48	48	388,36	A	25	14,54	PHS 16B-1A48
50	404,52	B	25	80	125	68	18,26	PHS 16B-1B50	50	404,52	A	25	15,86	PHS 16B-1A50
54	436,85	B	25	85	125	68	20,42	PHS 16B-1B54	54	436,85	A	30	18,51	PHS 16B-1A54
57	461,07	B	25	85	125	68	21,50	PHS 16B-1B57	57	461,07	A	30	20,50	PHS 16B-1A57
60	485,32	B	25	85	133	68	23,66	PHS 16B-1B60	60	485,32	A	30	22,95	PHS 16B-1A60
65	525,73	B	25	85	140	68	26,36	PHS 16B-1B65	65	525,73	A	30	27,03	PHS 16B-1A65
70	566,14	C	25	108	140	68	29,06	PHS 16B-1C70	70	566,14	A	30	31,11	PHS 16B-1A70
72	582,32	C	25	108	140	68	30,14	PHS 16B-1C72	72	582,32	A	30	32,74	PHS 16B-1A72
76	614,65	C	25	75	140	68	28,50	PHS 16B-1C76	76	614,65	A	30	36,00	PHS 16B-1A76
80	646,96	C	25	108	140	68	34,46	PHS 16B-1C80	80	646,96	A	30	40,42	PHS 16B-1A80
84	679,30	C	25	108	140	78	36,62	PHS 16B-1C84	84	679,30	A	30	44,84	PHS 16B-1A84
90	727,81	C	25	108	140	78	39,86	PHS 16B-1C90	90	727,81	A	30	51,47	PHS 16B-1A90
95	768,22	C	25	85	140	78	42,56	PHS 16B-1C95	95	768,22	A	30	57,00	PHS 16B-1A95
96	766,31	C	25	108	140	78	43,10	PHS 16B-1C96	96	766,31	A	30	58,11	PHS 16B-1A96
114	921,81	C	25	108	140	78	52,82	PHS 16B-1C114	114	921,81	A	30	78,00	PHS 16B-1A114

Maximum bores can accommodate standard keyways. Larger bores are available where a shallow keyway is used or no keyway is required.

For hardened teeth sprockets, add "H" after the sprocket profile e.g. PHS 08B-1AH8.

Type A

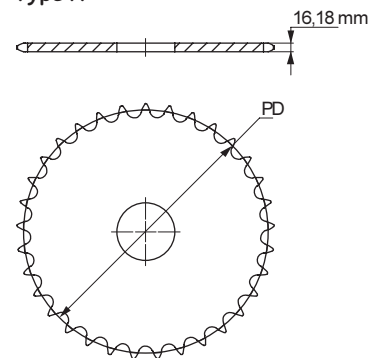

Type B

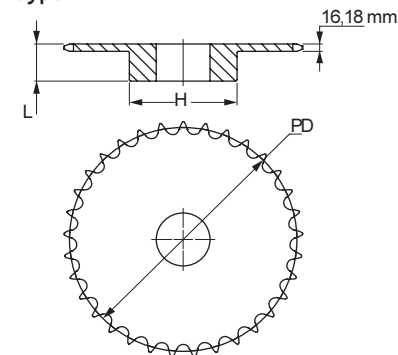

Type C

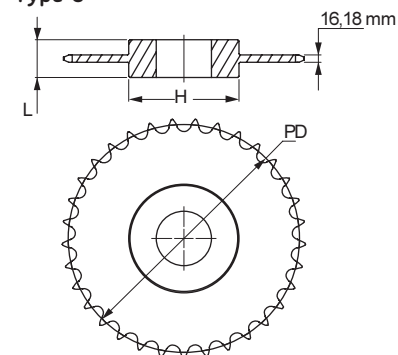



Metric sprockets



Simplex
Pilot bore

ISO 20B-1 31,75 mm Pitch

Pilot bore Type B/C

Type A

No. Teeth	Pitch Diameter	Type	Bore		Hub		Weight	Designation	No. Teeth	Pitch Diameter	Type	Bore	Weight	Designation
			Min	Max	H	L								
	mm		mm	mm	mm	mm	kg		mm		mm	kg		
8	82,97	B	20	57	53	40	1,04	PHS 20B-1B8	8	82,97	A	16	0,63	PHS 20B-1A8
9	92,83	B	20	57	63	40	1,45	PHS 20B-1B9	9	92,83	A	16	0,95	PHS 20B-1A9
10	102,75	B	20	60	70	40	1,86	PHS 20B-1B10	10	102,75	A	16	1,27	PHS 20B-1A10
11	112,70	B	20	70	77	45	2,40	PHS 20B-1B11	11	112,70	A	16	1,59	PHS 20B-1A11
12	122,67	B	20	76	88	45	2,95	PHS 20B-1B12	12	122,67	A	20	1,91	PHS 20B-1A12
13	132,67	B	20	76	98	45	3,00	PHS 20B-1B13	13	132,67	A	20	2,18	PHS 20B-1A13
14	142,68	B	20	76	108	45	3,40	PHS 20B-1B14	14	142,68	A	20	2,49	PHS 20B-1A14
15	152,71	B	20	76	118	50	4,31	PHS 20B-1B15	15	152,71	A	20	2,68	PHS 20B-1A15
16	162,75	B	20	76	120	50	4,63	PHS 20B-1B16	16	162,75	A	20	3,08	PHS 20B-1A16
17	172,79	B	25	76	120	50	4,99	PHS 20B-1B17	17	172,79	A	20	3,54	PHS 20B-1A17
18	182,84	B	25	76	120	50	5,44	PHS 20B-1B18	18	182,84	A	20	3,81	PHS 20B-1A18
19	192,90	B	25	76	120	50	5,90	PHS 20B-1B19	19	192,90	A	20	4,31	PHS 20B-1A19
20	202,96	B	25	76	120	50	6,35	PHS 20B-1B20	20	202,96	A	20	4,58	PHS 20B-1A20
21	213,03	B	25	76	140	55	7,03	PHS 20B-1B21	21	213,03	A	25	5,17	PHS 20B-1A21
22	223,10	B	25	76	140	55	7,71	PHS 20B-1B22	22	223,10	A	25	5,72	PHS 20B-1A22
23	233,17	B	25	84	140	55	8,16	PHS 20B-1B23	23	233,17	A	25	5,99	PHS 20B-1A23
24	243,25	B	25	84	140	55	8,62	PHS 20B-1B24	24	243,25	A	25	6,62	PHS 20B-1A24
25	253,32	B	25	84	140	55	9,07	PHS 20B-1B25	25	253,32	A	25	6,94	PHS 20B-1A25
26	263,41	B	25	84	150	55	9,53	PHS 20B-1B26	26	263,41	A	25	7,62	PHS 20B-1A26
27	273,49	B	25	84	150	55	10,43	PHS 20B-1B27	27	273,49	A	25	8,35	PHS 20B-1A27
28	283,57	B	25	84	150	55	11,34	PHS 20B-1B28	28	283,57	A	25	8,85	PHS 20B-1A28
29	293,66	B	25	84	150	55	11,76	PHS 20B-1B29	29	293,66	A	25	9,43	PHS 20B-1A29
30	303,75	B	25	84	150	55	12,02	PHS 20B-1B30	30	303,75	A	25	9,98	PHS 20B-1A30
31	313,83	B	25	84	150	55	12,77	PHS 20B-1B31	31	313,83	A	25	10,73	PHS 20B-1A31
32	323,92	B	25	84	150	55	13,52	PHS 20B-1B32	32	323,92	A	25	11,49	PHS 20B-1A32
33	334,01	B	25	84	150	55	14,59	PHS 20B-1B33	33	334,01	A	25	12,24	PHS 20B-1A33
34	344,10	B	25	84	150	55	15,66	PHS 20B-1B34	34	344,10	A	25	13,00	PHS 20B-1A34
35	354,20	B	25	84	150	55	16,74	PHS 20B-1B35	35	354,20	A	25	13,75	PHS 20B-1A35
36	364,29	B	25	84	150	55	17,51	PHS 20B-1B36	36	364,29	A	25	14,50	PHS 20B-1A36
37	374,38	B	25	84	150	55	18,17	PHS 20B-1B37	37	374,38	A	25	15,25	PHS 20B-1A37
38	384,48	B	25	84	150	55	18,82	PHS 20B-1B38	38	384,48	A	25	16,01	PHS 20B-1A38
39	394,57	B	25	84	150	55	19,78	PHS 20B-1B39	39	394,57	A	25	16,76	PHS 20B-1A39
40	404,67	B	25	84	150	55	21,27	PHS 20B-1B40	40	404,67	A	25	17,52	PHS 20B-1A40
41	414,77	B	25	84	150	70	22,07	PHS 20B-1B41	41	414,77	A	30	18,27	PHS 20B-1A41
42	424,88	B	25	84	150	70	22,86	PHS 20B-1B42	42	424,88	A	30	19,03	PHS 20B-1A42
43	434,96	B	25	84	150	70	23,40	PHS 20B-1B43	43	434,96	A	30	19,78	PHS 20B-1A43
44	445,06	B	25	84	150	70	23,95	PHS 20B-1B44	44	445,06	A	30	20,53	PHS 20B-1A44
45	455,15	B	25	84	150	70	24,49	PHS 20B-1B45	45	455,15	A	30	21,29	PHS 20B-1A45
46	465,25	B	25	84	150	70	26,31	PHS 20B-1B46	46	465,25	A	30	22,04	PHS 20B-1A46
47	475,35	B	25	84	150	70	28,12	PHS 20B-1B47	47	475,35	A	30	22,79	PHS 20B-1A47
48	485,45	B	25	102	150	70	29,94	PHS 20B-1B48	48	485,45	A	30	23,55	PHS 20B-1A48
49	495,55	B	25	102	150	70	31,76	PHS 20B-1B49	49	495,55	A	30	24,30	PHS 20B-1A49
50	505,65	B	25	102	150	70	33,57	PHS 20B-1B50	50	505,65	A	30	25,06	PHS 20B-1A50
51	515,75	B	25	102	150	80	35,39	PHS 20B-1B51	51	515,75	A	30	24,43	PHS 20B-1A51
52	525,85	B	25	102	150	80	37,21	PHS 20B-1B52	52	525,85	A	30	25,85	PHS 20B-1A52
53	535,95	B	25	102	150	80	39,02	PHS 20B-1B53	53	535,95	A	30	27,27	PHS 20B-1A53
54	546,05	C	25	102	150	80	32,90	PHS 20B-1C54	54	546,05	A	30	25,70	PHS 20B-1A54
55	556,13	C	25	102	150	80	34,77	PHS 20B-1C55	55	556,15	A	30	30,12	PHS 20B-1A55
56	566,25	C	25	102	150	80	36,63	PHS 20B-1C56	56	566,25	A	30	31,34	PHS 20B-1A56
57	576,35	C	25	102	150	80	38,50	PHS 20B-1C57	57	576,35	A	30	32,96	PHS 20B-1A57
58	586,45	C	25	102	150	80	40,37	PHS 20B-1C58	58	586,45	A	30	35,80	PHS 20B-1A58
59	596,56	C	25	102	150	80	42,24	PHS 20B-1C59	59	596,56	A	30	37,22	PHS 20B-1A59
60	606,66	C	25	102	150	80	44,10	PHS 20B-1C60	60	606,66	A	30	38,64	PHS 20B-1A60
70	707,68	C	25	133	150	80	65,36	PHS 20B-1C70	70	707,68	A	30	52,85	PHS 20B-1A70
72	727,89	C	25	133	150	80	67,23	PHS 20B-1C72	72	727,89	A	30	55,70	PHS 20B-1A72
76	768,30	C	25	133	150	80	70,98	PHS 20B-1C76	76	768,30	A	30	61,38	PHS 20B-1A76
80	808,71	C	25	133	150	80	74,70	PHS 20B-1C80	80	808,71	A	30	67,06	PHS 20B-1A80
84	849,13	C	25	133	150	90	78,43	PHS 20B-1C84	84	849,13	A	30	72,75	PHS 20B-1A84
90	909,76	C	25	133	150	90	84,03	PHS 20B-1C90	90	909,76	A	30	81,27	PHS 20B-1A90
95	960,28	C	25	133	150	90	117,18	PHS 20B-1C95	95	960,28	A	30	102,42	PHS 20B-1A95
96	970,38	C	25	133	150	90	117,56	PHS 20B-1C96	96	970,38	A	30	103,84	PHS 20B-1A96
114	1152,27	C	25	133	150	90	124,40	PHS 20B-1C114	114	1152,27	A	30	130,84	PHS 20B-1A114

Type A

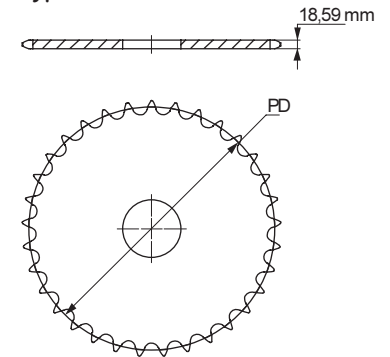

Type B

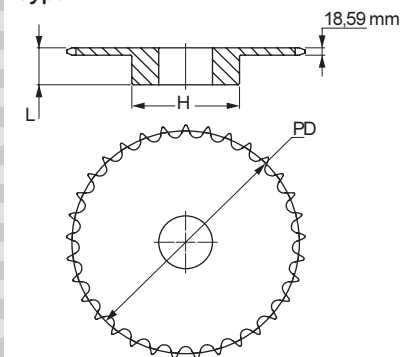

Type C

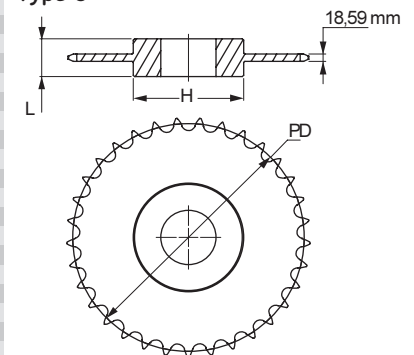

Maximum bores can accommodate standard keyways. Larger bores are available where a shallow keyway is used or no keyway is required.

For hardened teeth sprockets, add "H" after the sprocket profile e.g. PHS 08B-1AH8.



Metric sprockets

Simplex

Pilot bore

- ▶ Belts
- ▶ Chains
- ▶ Couplings
- ▶ Bushings and Hubs
- ▶ Sprockets
- ▶ Pulleys
- ▶ Smart tools

ISO 24B-1 38,10 mm Pitch

Pilot bore Type B/C

Type A

No. Teeth	Pitch Diameter mm	Type	Bore		Hub		Weight kg	Designation	No. Teeth	Pitch Diameter mm	Type	Bore Stock mm	Weight kg	Designation
			Min mm	Max mm	H mm	L mm								
9	111,40	B	20	45	70	45	2,02	PHS 24B-1B9	9	111,40	A	20	1,69	PHS 24B-1A9
10	123,29	B	20	52	80	45	2,61	PHS 24B-1B10	10	123,29	A	20	1,88	PHS 24B-1A10
11	135,23	B	25	60	90	50	3,77	PHS 24B-1B11	11	135,23	A	20	2,06	PHS 24B-1A11
12	147,21	B	25	67	102	50	4,77	PHS 24B-1B12	12	147,21	A	20	2,68	PHS 24B-1A12
13	159,20	B	25	76	114	50	5,91	PHS 24B-1B13	13	159,20	A	20	3,06	PHS 24B-1A13
14	171,22	B	25	86	128	50	6,68	PHS 24B-1B14	14	171,22	A	20	3,72	PHS 24B-1A14
15	183,25	B	25	92	132	50	7,49	PHS 24B-1B15	15	183,25	A	20	4,31	PHS 24B-1A15
16	195,29	B	25	92	136	55	9,08	PHS 24B-1B16	16	195,29	A	25	4,86	PHS 24B-1A16
17	207,35	B	25	92	136	55	9,76	PHS 24B-1B17	17	207,35	A	25	5,44	PHS 24B-1A17
18	219,41	B	25	92	136	55	10,49	PHS 24B-1B18	18	219,41	A	25	6,13	PHS 24B-1A18
19	231,48	B	25	92	136	55	11,21	PHS 24B-1B19	19	231,48	A	25	7,03	PHS 24B-1A19
20	243,55	B	25	92	136	55	12,26	PHS 24B-1B20	20	243,55	A	25	7,94	PHS 24B-1A20
21	255,63	B	25	92	150	60	13,38	PHS 24B-1B21	21	255,63	A	25	8,62	PHS 24B-1A21
22	267,72	B	25	92	150	60	13,67	PHS 24B-1B22	22	267,72	A	25	9,76	PHS 24B-1A22
23	179,80	B	25	92	150	60	14,74	PHS 24B-1B23	23	179,80	A	25	10,43	PHS 24B-1A23
24	291,90	B	25	92	150	60	15,48	PHS 24B-1B24	24	291,90	A	25	11,35	PHS 24B-1A24
25	303,99	B	25	92	150	60	16,38	PHS 24B-1B25	25	303,99	A	25	12,47	PHS 24B-1A25
26	316,09	B	30	102	150	40	19,43	PHS 24B-1B26	26	316,09	A	30	13,39	PHS 24B-1A26
27	328,19	B	30	102	150	40	20,39	PHS 24B-1B27	27	328,19	A	30	14,53	PHS 24B-1A27
28	340,29	B	30	102	150	40	21,34	PHS 24B-1B28	28	340,29	A	30	15,89	PHS 24B-1A28
29	352,39	B	30	102	150	40	22,79	PHS 24B-1B29	29	352,39	A	30	17,02	PHS 24B-1A29
30	364,49	B	30	102	150	40	24,25	PHS 24B-1B30	30	364,49	A	30	18,39	PHS 24B-1A30
31	376,60	B	30	102	150	40	26,19	PHS 24B-1B31	31	376,60	A	30	20,02	PHS 24B-1A31
32	388,71	B	30	102	150	40	28,12	PHS 24B-1B32	32	388,71	A	30	21,66	PHS 24B-1A32
33	400,82	B	30	102	150	40	30,05	PHS 24B-1B33	33	400,82	A	30	23,29	PHS 24B-1A33
34	412,93	B	30	102	150	40	31,99	PHS 24B-1B34	34	412,93	A	30	24,93	PHS 24B-1A34
35	425,04	B	30	102	150	40	33,93	PHS 24B-1B35	35	425,04	A	30	26,56	PHS 24B-1A35
36	437,15	B	30	102	150	40	35,86	PHS 24B-1B36	36	437,15	A	30	28,19	PHS 24B-1A36
38	461,37	B	30	102	150	40	39,73	PHS 24B-1B38	38	461,37	A	30	31,46	PHS 24B-1A38
40	485,60	B	30	102	150	40	42,52	PHS 24B-1B40	40	485,60	A	30	36,23	PHS 24B-1A40
42	509,83	C	30	102	160	90	45,31	PHS 24B-1C42	42	509,83	A	30	40,99	PHS 24B-1A42
45	546,19	C	30	102	160	90	50,71	PHS 24B-1C45	45	546,19	A	30	48,14	PHS 24B-1A45
48	482,54	C	30	102	160	90	57,43	PHS 24B-1C48	48	482,54	A	30	55,29	PHS 24B-1A48
50	606,78	C	30	102	160	90	61,57	PHS 24B-1C50	50	606,78	A	30	60,05	PHS 24B-1A50
54	655,26	C	30	102	160	100	69,84	PHS 24B-1C54	54	655,26	A	30	69,58	PHS 24B-1A54
57	691,62	C	30	133	160	100	76,05	PHS 24B-1C57	57	691,62	A	30	76,73	PHS 24B-1A57
60	727,99	C	30	133	160	100	80,05	PHS 24B-1C60	60	727,99	A	30	85,19	PHS 24B-1A60
68	824,97	C	30	133	160	100	93,39	PHS 24B-1C68	68	824,97	A	40	107,74	PHS 24B-1A68
72	873,43	C	30	133	160	100	111,51	PHS 24B-1C72	72	873,43	A	40	119,02	PHS 24B-1A72
76	921,96	C	30	133	160	100	129,62	PHS 24B-1C76	76	921,96	A	40	130,30	PHS 24B-1A76
95	921,96	C	30	133	160	100	215,67	PHS 24B-1C95	95	921,96	A	40	183,88	PHS 24B-1A95
96	921,96	C	30	133	160	100	220,20	PHS 24B-1C96	96	921,96	A	40	186,70	PHS 24B-1A96
114	921,96	C	30	133	160	100	301,71	PHS 24B-1C114	114	921,96	A	40	237,46	PHS 24B-1A114

Maximum bores can accommodate standard keyways. Larger bores are available where a shallow keyway is used or no keyway is required.

For hardened teeth sprockets, add "H" after the sprocket profile e.g. PHS 08B-1AH8.

Type A

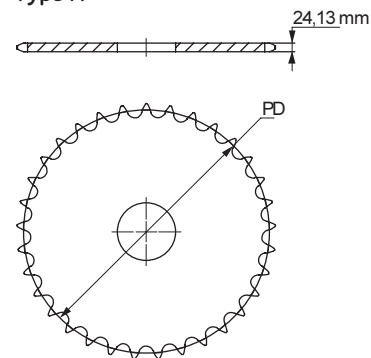

Type B

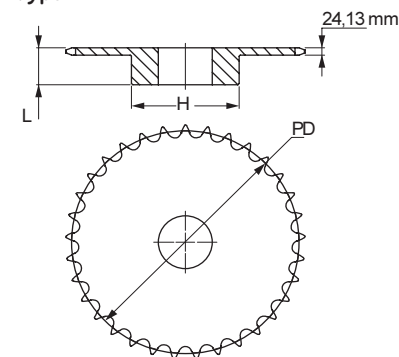

Type C

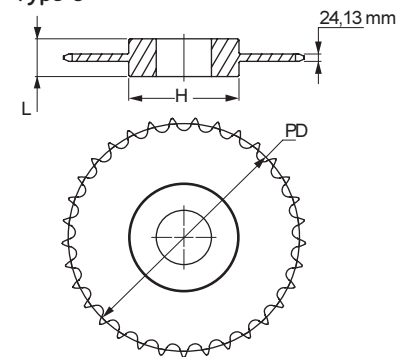

Metric sprockets



Simplex
Pilot bore

ISO 28B-1 44,45 mm Pitch

Type A

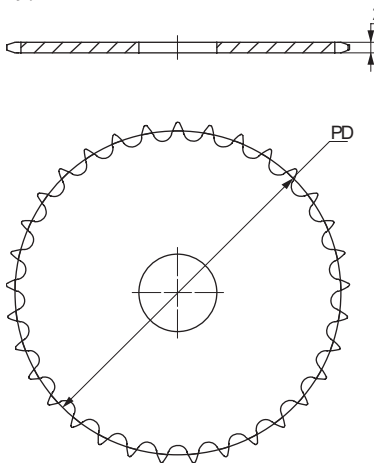

Type B

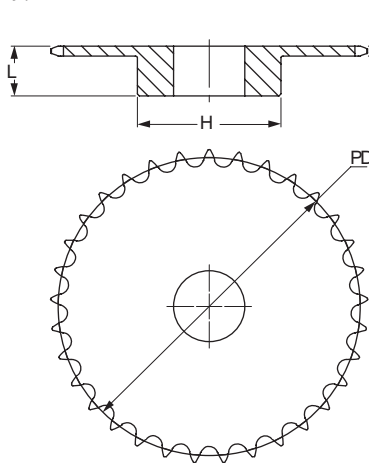

Type C

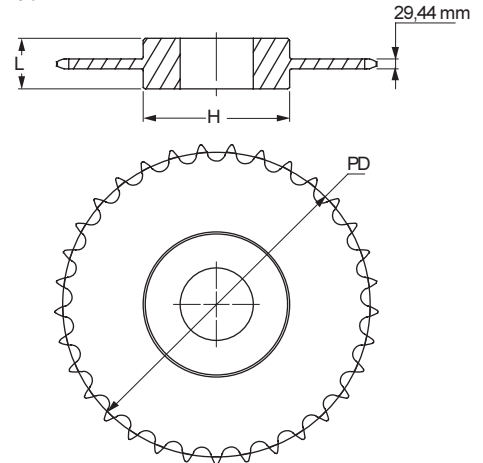

Pilot bore Type B/C

Type A

No. Teeth	Pitch Diameter	Type	Bore		Hub		Weight	Designation	No. Teeth	Pitch Diameter	Type	Bore Stock	Weight	Designation
			Min	Max	H	L								
11	157,77	B	25	73	112	70	5,27	PHS 28B-1B11	11	157,77	A	20	3,18	PHS 28B-1A11
12	171,74	B	25	84	125	70	6,40	PHS 28B-1B12	12	171,74	A	20	3,95	PHS 28B-1A12
13	185,74	B	25	93	125	70	8,22	PHS 28B-1B13	13	185,74	A	20	4,31	PHS 28B-1A13
14	199,76	B	25	93	125	70	9,13	PHS 28B-1B14	14	199,76	A	20	4,77	PHS 28B-1A14
15	213,79	B	25	108	125	70	11,40	PHS 28B-1B15	15	213,79	A	20	5,45	PHS 28B-1A15
16	227,84	B	30	108	160	75	12,76	PHS 28B-1B16	16	227,84	A	30	6,81	PHS 28B-1A16
17	241,91	B	30	108	160	75	13,65	PHS 28B-1B17	17	241,91	A	30	7,71	PHS 28B-1A17
18	255,98	B	30	108	160	75	13,65	PHS 28B-1B18	18	255,98	A	30	8,63	PHS 28B-1A18
19	270,06	B	30	108	160	75	15,01	PHS 28B-1B19	19	270,06	A	30	9,53	PHS 28B-1A19
20	284,14	B	30	108	160	75	16,84	PHS 28B-1B20	20	284,14	A	30	10,44	PHS 28B-1A20
21	298,24	B	30	108	160	75	18,19	PHS 28B-1B21	21	298,24	A	30	11,79	PHS 28B-1A21
22	312,34	B	30	108	160	75	19,11	PHS 28B-1B22	22	312,34	A	30	13,17	PHS 28B-1A22
23	326,44	B	30	108	160	75	20,46	PHS 28B-1B23	23	326,44	A	30	14,06	PHS 28B-1A23
24	340,54	B	30	108	160	75	21,84	PHS 28B-1B24	24	340,54	A	30	15,44	PHS 28B-1A24
25	354,65	B	30	108	160	75	22,73	PHS 28B-1B25	25	354,65	A	30	16,78	PHS 28B-1A25
26	368,77	B	30	108	160	75	26,83	PHS 28B-1B26	26	368,77	A	30	18,61	PHS 28B-1A26
27	382,88	B	30	108	160	75	27,74	PHS 28B-1B27	27	382,88	A	30	20,43	PHS 28B-1A27
28	397,00	B	30	108	160	75	30,29	PHS 28B-1B28	28	397,00	A	30	20,88	PHS 28B-1A28
30	425,24	B	30	108	160	75	32,73	PHS 28B-1B30	30	425,24	A	30	25,17	PHS 28B-1A30
32	453,49	B	30	134	180	75	34,84	PHS 28B-1B32	32	453,49	A	30	31,02	PHS 28B-1A32
38	538,27	B	30	134	180	75	51,25	PHS 28B-1B38	38	538,27	A	30	48,58	PHS 28B-1A38
40	566,54	C	30	134	180	75	52,84	PHS 28B-1C40	40	566,54	A	30	52,80	PHS 28B-1A40
42	594,81	C	30	134	180	90	54,43	PHS 28B-1C42	42	594,81	A	30	57,02	PHS 28B-1A42
45	637,22	C	30	134	180	90	60,55	PHS 28B-1C45	45	637,22	A	30	63,35	PHS 28B-1A45
48	679,63	C	30	134	180	90	62,72	PHS 28B-1C48	48	679,63	A	30	69,68	PHS 28B-1A48
54	764,47	C	30	134	180	100	74,60	PHS 28B-1C54	54	764,47	A	30	82,34	PHS 28B-1A54
57	806,89	C	30	134	180	100	81,77	PHS 28B-1C57	57	806,89	A	40	88,67	PHS 28B-1A57
60	849,32	C	30	134	180	100	88,94	PHS 28B-1C60	60	849,32	A	40	97,97	PHS 28B-1A60
68	962,47	C	30	137	180	100	108,05	PHS 28B-1C68	68	962,47	A	40	122,79	PHS 28B-1A68
72	1019,04	C	30	137	180	100	117,61	PHS 28B-1C72	72	1019,04	A	40	135,19	PHS 28B-1A72
76	1075,62	C	30	137	180	100	127,17	PHS 28B-1C76	76	1075,62	A	40	147,60	PHS 28B-1A76
95	1344,39	C	30	137	180	100	172,57	PHS 28B-1C95	95	1344,39	A	40	206,53	PHS 28B-1A95

Maximum bores can accommodate standard keyways. Larger bores are available where a shallow keyway is used or no keyway is required.

For hardened teeth sprockets, add "H" after the sprocket profile e.g. PHS 08B-1AH8.



Metric sprockets

Simplex
Pilot bore

- ▶ Belts
- ▶ Chains
- ▶ Couplings
- ▶ Bushings and Hubs
- ▶ Sprockets
- ▶ Pulleys
- ▶ Smart tools

ISO 32B-1 50,80 mm Pitch

Type A

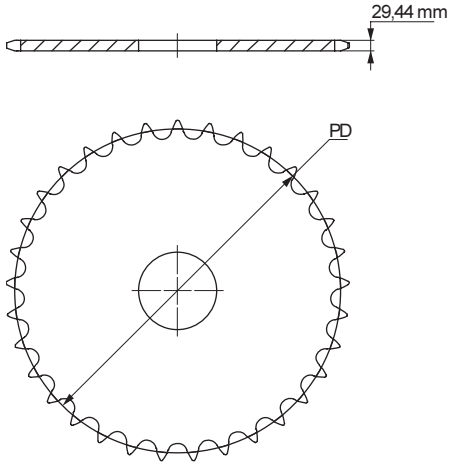

Type B

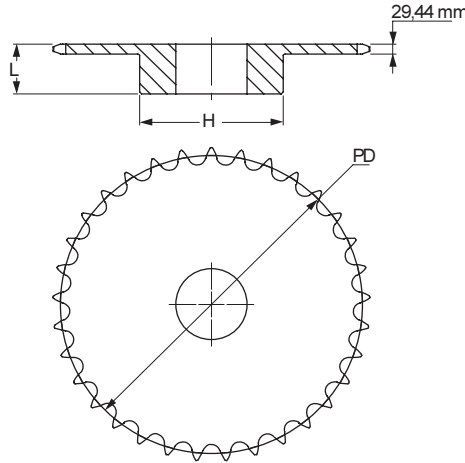

Type C

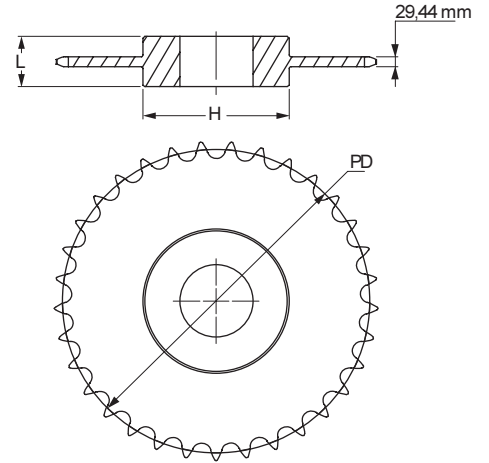

Pilot bore Type B/C

Type A

No. Teeth	Pitch Diameter	Type	Bore		Hub		Weight	Designation	No. Teeth	Pitch Diameter	Type	Bore Stock	Weight	Designation
			Min	Max	H	L								
11	180,31	B	30	83	120	90	9,04	PHS 32B-1B11	11	180,31	A	25	5,00	PHS 32B-1A11
12	196,28	B	30	89	133	90	11,11	PHS 32B-1B12	12	196,28	A	25	6,02	PHS 32B-1A12
13	212,27	B	30	102	145	90	12,61	PHS 32B-1B13	13	212,27	A	25	7,12	PHS 32B-1A13
14	228,29	B	30	102	145	90	14,97	PHS 32B-1B14	14	228,29	A	30	8,32	PHS 32B-1A14
15	244,33	B	30	102	145	90	17,32	PHS 32B-1B15	15	244,33	A	30	9,50	PHS 32B-1A15
16	260,39	B	30	103	160	90	18,78	PHS 32B-1B16	16	260,39	A	30	11,64	PHS 32B-1A16
17	276,46	B	30	103	160	90	20,23	PHS 32B-1B17	17	276,46	A	30	12,35	PHS 32B-1A17
18	292,55	B	30	103	160	90	21,88	PHS 32B-1B18	18	292,55	A	30	13,96	PHS 32B-1A18
19	308,64	B	30	103	160	90	23,53	PHS 32B-1B19	19	308,64	A	30	15,57	PHS 32B-1A19
20	324,74	B	30	133	180	90	25,37	PHS 32B-1B20	20	324,74	A	30	17,36	PHS 32B-1A20
21	340,84	B	30	133	180	90	27,20	PHS 32B-1B21	21	340,84	A	30	19,15	PHS 32B-1A21
22	356,96	B	30	133	180	90	29,23	PHS 32B-1B22	22	356,96	A	30	21,13	PHS 32B-1A22
23	373,07	B	30	133	180	90	31,25	PHS 32B-1B23	23	373,07	A	30	23,10	PHS 32B-1A23
24	389,19	B	30	133	180	90	35,33	PHS 32B-1B24	24	389,19	A	30	25,26	PHS 32B-1A24
25	405,32	B	30	133	180	90	36,80	PHS 32B-1B25	25	405,32	A	30	27,41	PHS 32B-1A25
26	421,45	B	30	133	180	90	39,41	PHS 32B-1B26	26	421,45	A	30	30,25	PHS 32B-1A26
27	437,58	B	30	133	180	90	42,02	PHS 32B-1B27	27	437,58	A	30	33,10	PHS 32B-1A27
28	453,72	B	30	133	180	90	44,62	PHS 32B-1B28	28	453,72	A	30	35,94	PHS 32B-1A28
30	485,99	B	30	133	180	90	49,84	PHS 32B-1B30	30	485,99	A	30	41,63	PHS 32B-1A30
32	518,28	B	30	139	180	90	58,02	PHS 32B-1B32	32	518,28	A	30	47,31	PHS 32B-1A32
38	615,17	B	30	139	180	90	86,78	PHS 32B-1B38	38	615,17	A	30	64,37	PHS 32B-1A38
40	647,47	C	30	139	180	90	91,35	PHS 32B-1C40	40	647,47	A	40	72,98	PHS 32B-1A40
42	679,78	C	30	139	180	90	95,91	PHS 32B-1C42	42	679,78	A	40	81,60	PHS 32B-1A42
45	728,25	C	30	139	180	100	116,97	PHS 32B-1C45	45	728,25	A	40	94,52	PHS 32B-1A45
48	790,72	C	30	139	180	100	130,43	PHS 32B-1C48	48	790,72	A	40	107,44	PHS 32B-1A48
54	873,68	C	30	139	180	100	157,34	PHS 32B-1C54	54	873,68	A	40	133,29	PHS 32B-1A54
57	922,16	C	30	139	180	100	190,79	PHS 32B-1C57	57	922,16	A	40	146,21	PHS 32B-1A57
60	990,65	C	30	139	200	110	184,25	PHS 32B-1C60	60	990,65	A	40	164,35	PHS 32B-1A60
68	1099,96	C	30	139	200	110	220,13	PHS 32B-1C68	68	1099,96	A	40	212,73	PHS 32B-1A68
72	1164,62	C	30	139	200	110	282,31	PHS 32B-1C72	72	1164,62	A	40	236,91	PHS 32B-1A72
90	1229,28	C	30	139	200	110	297,99	PHS 32B-1C90	90	1229,28	A	40	261,10	PHS 32B-1A90

Maximum bores can accommodate standard keyways. Larger bores are available where a shallow keyway is used or no keyway is required.

For hardened teeth sprockets, add "H" after the sprocket profile e.g. PHS 08B-1AH8.



Metric sprockets



Simplex
Bored-to-size

ISO 06B-1 9,525 mm Pitch

Bored-to-size Type BS

No. Teeth	Pitch Diameter	L	Weight	Designation	Finished Bores (mm)												
					Includes Keyway and Setscrew												
	mm	mm	kg		10*	11	12→	14→	-	-	-	-	-	-	-	-	-
10	30,82	22	0,05	PHS 06B-1BS10X...	10*	11	12→	14→	-	-	-	-	-	-	-	-	-
11	33,80	25	0,07	PHS 06B-1BS11X...	10*	-	12→	14→	16	-	-	-	-	-	-	-	-
12	36,80	25	0,08	PHS 06B-1BS12X...	10*	-	12*	14	16	-	-	-	-	-	-	-	-
13	39,79	25	0,09	PHS 06B-1BS13X...	10*	-	12*	14	16	18	-	-	-	-	-	-	-
14	42,80	25	0,10	PHS 06B-1BS14X...	-	-	12*	14	16	18	19	-	-	-	-	-	-
15	45,81	25	0,11	PHS 06B-1BS15X...	-	-	12*	14	16	18	19	20	22	24	25	-	-
16	48,82	28	0,13	PHS 06B-1BS16X...	-	-	12*	14	16	18	19	20	22	24	25	-	-
17	51,83	28	0,16	PHS 06B-1BS17X...	-	-	12*	14	16	18	19	20	22	24	25	-	-
18	54,85	28	0,18	PHS 06B-1BS18X...	-	-	12*	14	16	18	19	20	22	24	25	-	-
19	57,87	28	0,20	PHS 06B-1BS19X...	-	-	12*	14	16	18	19	20	22	24	25	-	-
20	60,89	28	0,23	PHS 06B-1BS20X...	-	-	12*	14	16	18	19	20	22	24	25	-	-
21	63,91	28	0,34	PHS 06B-1BS21X...	-	-	-	-	16	18	19	20	22	24	25	-	-
22	66,93	28	0,35	PHS 06B-1BS22X...	-	-	-	-	16	18	19	20	22	24	25	-	-
23	69,95	28	0,35	PHS 06B-1BS23X...	-	-	-	-	16	18	19	20	22	24	25	-	-
24	72,97	28	0,36	PHS 06B-1BS24X...	-	-	-	-	16	18	19	20	22	24	25	-	-
25	76,00	28	0,36	PHS 06B-1BS25X...	-	-	-	-	16	18	19	20	22	24	25	-	-
26	79,02	28	0,38	PHS 06B-1BS26X...	-	-	-	-	16	18	19	20	22	24	25	-	-
27	82,05	28	0,38	PHS 06B-1BS27X...	-	-	-	-	16	18	19	20	22	24	25	-	-
28	85,07	28	0,39	PHS 06B-1BS28X...	-	-	-	-	16	18	19	20	22	24	25	-	-
29	88,10	28	0,40	PHS 06B-1BS29X...	-	-	-	-	16	18	19	20	22	24	25	-	-
30	91,12	28	0,41	PHS 06B-1BS30X...	-	-	-	-	16	18	19	20	22	24	25	-	-

Hub diameters vary with bore size

* No Keyway

→Keyway with setscrews at 90° & 180°

For hardened teeth sprockets, add "H" after the sprocket profile e.g. PHS 08B-1AH8.

Type BS

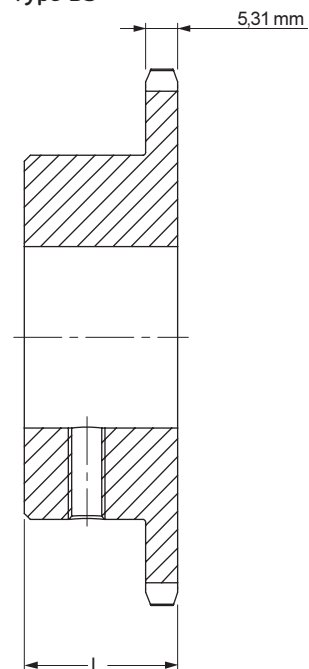

ISO 08B-1 12,70 mm Pitch

Bored-to-size Type BS

No. Teeth	Pitch Diameter	L	Weight	Designation	Finished Bores (mm)												
					Includes Keyway and Setscrew												
	mm	mm	kg		12*	14	16	-	-	-	-	-	-	-	-	-	-
10	41,10	25	0,11	PHS 08B-1BS10X...	12*	14	16	-	-	-	-	-	-	-	-	-	-
11	45,07	25	0,13	PHS 08B-1BS11X...	12*	14	16	18	19	-	-	-	-	-	-	-	-
12	49,07	28	0,15	PHS 08B-1BS12X...	12*	14	16	18	19	20	22	24	25	-	-	-	-
13	53,06	28	0,20	PHS 08B-1BS13X...	12*	14	16	18	19	20	22	24	25	28	-	-	-
14	57,07	28	0,23	PHS 08B-1BS14X...	12*	14	16	18	19	20	22	24	25	28	-	-	-
15	61,09	28	0,24	PHS 08B-1BS15X...	12*	14	16	18	19	20	22	24	25	28	30	32	-
16	65,10	28	0,30	PHS 08B-1BS16X...	-	-	16	18	19	20	22	24	25	28	30	32	-
17	69,11	28	0,40	PHS 08B-1BS17X...	-	-	16	18	19	20	22	24	25	28	30	32	-
18	73,14	28	0,47	PHS 08B-1BS18X...	-	-	16	18	19	20	22	24	25	28	30	32	35
19	77,16	28	0,53	PHS 08B-1BS19X...	-	-	16	18	19	20	22	24	25	28	30	32	35
20	81,19	28	0,60	PHS 08B-1BS20X...	-	-	16	18	19	20	22	24	25	28	30	32	35
21	85,22	28	0,69	PHS 08B-1BS21X...	-	-	16	18	19	20	22	24	25	28	30	32	35
22	89,24	28	0,75	PHS 08B-1BS22X...	-	-	16	18	19	20	22	24	25	28	30	32	35
23	93,27	28	0,87	PHS 08B-1BS23X...	-	-	-	-	19	20	22	24	25	28	30	32	35
24	97,29	28	0,95	PHS 08B-1BS24X...	-	-	-	-	19	20	22	24	25	28	30	32	35
25	101,33	28	1,01	PHS 08B-1BS25X...	-	-	-	-	19	20	22	24	25	28	30	32	35
26	105,36	30	1,09	PHS 08B-1BS26X...	-	-	-	-	19	20	22	24	25	28	30	32	35
27	109,40	30	1,13	PHS 08B-1BS27X...	-	-	-	-	19	20	22	24	25	28	30	32	35
28	113,42	30	1,17	PHS 08B-1BS28X...	-	-	-	-	19	20	22	24	25	28	30	32	35
30	121,50	30	1,46	PHS 08B-1BS30X...	-	-	-	-	19	20	22	24	25	28	30	32	35

Hub diameters vary with bore size

* No Keyway

For hardened teeth sprockets, add "H" after the sprocket profile e.g. PHS 08B-1AH8.

Type BS

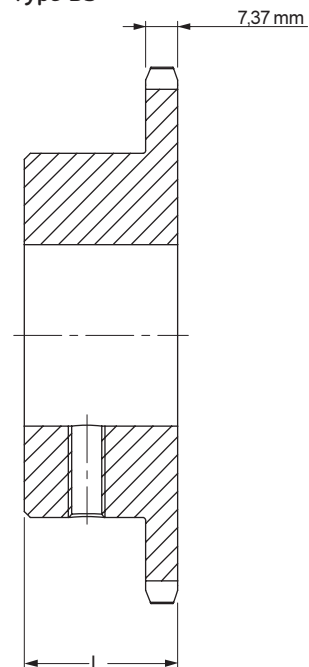



Metric sprockets

Simplex

Bored-to-size

- ▶ Belts
- ▶ Chains
- ▶ Couplings
- ▶ Bushings and Hubs
- ▶ Sprockets
- ▶ Pulleys
- ▶ Smart tools

ISO 10B-1 15,88 mm Pitch

Bored-to-size Type BS

No. Teeth	Pitch Diameter	L	Weight	Designation	Finished Bores (mm) Includes Keyway and Setscrew															
	mm				mm	kg	16	18	19	20	22	24	25	28	30	32	35	38	40	42
10	51,37	25	0,14	PHS 10B-1BS10X...	16	-	19	20	-	24*	-	-	-	-	-	-	-	-		
11	56,34	30	0,27	PHS 10B-1BS11X...	16	18	19	20	22	24	25	28	30	32	-	-	-	-		
12	61,34	30	0,32	PHS 10B-1BS12X...	16	18	19	20	22	24	25	28	30	32	-	-	-	-		
13	66,32	30	0,36	PHS 10B-1BS13X...	16	18	19	20	22	24	25	28	30	32	-	-	-	-		
14	71,34	30	0,45	PHS 10B-1BS14X...	16	18	19	20	22	24	25	28	30	32	35	-	-	-		
15	76,36	30	0,54	PHS 10B-1BS15X...	-	-	19	20	22	24	25	28	30	32	35	38	-	-		
16	81,37	30	0,66	PHS 10B-1BS16X...	-	-	19	20	22	24	25	28	30	32	35	38	-	-		
17	86,38	30	0,73	PHS 10B-1BS17X...	-	-	19	20	22	24	25	28	30	32	35	38	40	42		
18	91,42	30	0,86	PHS 10B-1BS18X...	-	-	19	20	22	24	25	28	30	32	35	38	40	42		
19	96,45	30	0,91	PHS 10B-1BS19X...	-	-	19	20	22	24	25	28	30	32	35	38	40	42		
20	101,49	30	0,95	PHS 10B-1BS20X...	-	-	19	20	22	24	25	28	30	32	35	38	40	42		
21	106,52	30	1,02	PHS 10B-1BS21X...	-	-	19	20	22	24	25	28	30	32	35	38	40	42		
22	111,55	30	1,09	PHS 10B-1BS22X...	-	-	19	20	22	24	25	28	30	32	35	38	40	42		
23	116,58	30	1,13	PHS 10B-1BS23X...	-	-	19	20	22	24	25	28	30	32	35	38	40	42		
24	121,62	30	1,36	PHS 10B-1BS24X...	-	-	19	20	22	24	25	28	30	32	35	38	40	42		
25	126,66	30	1,45	PHS 10B-1BS25X...	-	-	19	20	22	24	25	28	30	32	35	38	40	42		
26	131,70	35	1,53	PHS 10B-1BS26X...	-	-	19	20	22	24	25	28	30	32	35	38	40	42		
27	136,75	35	1,62	PHS 10B-1BS27X...	-	-	19	20	22	24	25	28	30	32	35	38	40	42		
28	141,78	35	1,71	PHS 10B-1BS28X...	-	-	19	20	22	24	25	28	30	32	35	38	40	42		
29	146,83	35	1,80	PHS 10B-1BS29X...	-	-	19	20	22	24	25	28	30	32	35	38	40	42		
30	151,87	35	1,88	PHS 10B-1BS30X...	-	-	19	20	22	24	25	28	30	32	35	38	40	42		

Hub diameters vary with bore size

* Keyway with setscrews at 90° & 180°

For hardened teeth sprockets, add "H" after the sprocket profile e.g. PHS 08B-1AH8.

Type BS

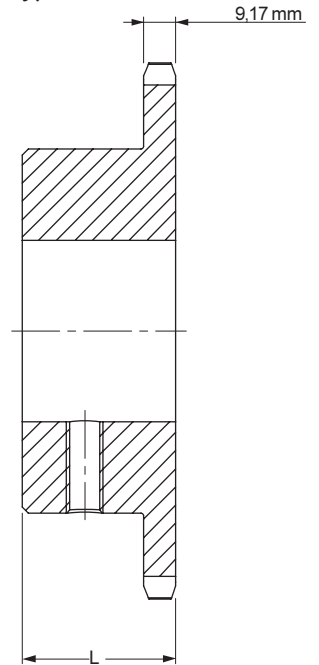

ISO 12B-1 19,05 mm Pitch

Bored-to-size Type BS

No. Teeth	Pitch Diameter	L	Weight	Designation	Finished Bores (mm) Includes Keyway and Setscrew															
	mm				mm	kg	19	20	-	24	25	28	30	32	-	-	-	-	-	-
10	61,64	30	0,32	PHS 12B-1BS10X...	19	20	-	24	25	28	30	32	-	-	-	-	-	-		
11	67,61	35	0,41	PHS 12B-1BS11X...	19	20	-	24	25	28	30	32	-	-	-	-	-	-		
12	73,61	35	0,59	PHS 12B-1BS12X...	19	20	22	24	25	28	30	32	35	-	-	-	-	-		
13	79,59	35	0,59	PHS 12B-1BS13X...	19	20	22	24	25	28	30	32	35	38	-	-	-	-		
14	85,61	35	0,73	PHS 12B-1BS14X...	19	20	22	24	25	28	30	32	35	38	40	-	-	-		
15	91,63	35	0,77	PHS 12B-1BS15X...	19	20	22	24	25	28	30	32	35	38	40	-	-	-		
16	97,65	35	0,95	PHS 12B-1BS16X...	19	20	22	24	25	28	30	32	35	38	40	42	-	-		
17	103,67	35	1,09	PHS 12B-1BS17X...	-	-	-	-	25	28	30	32	35	38	40	42	-	-		
18	109,71	35	1,18	PHS 12B-1BS18X...	-	-	-	-	25	28	30	32	35	38	40	42	45	48	50	
19	115,75	35	1,54	PHS 12B-1BS19X...	-	-	-	-	25	28	30	32	35	38	40	42	45	48	50	
20	121,78	35	1,77	PHS 12B-1BS20X...	-	-	-	-	25	28	30	32	35	38	40	42	45	48	50	
21	127,82	35	2,00	PHS 12B-1BS21X...	-	-	-	-	25	28	30	32	35	38	40	42	45	48	50	
22	133,86	40	2,13	PHS 12B-1BS22X...	-	-	-	-	25	28	30	32	35	38	40	42	45	48	50	
23	139,90	40	2,27	PHS 12B-1BS23X...	-	-	-	-	25	28	30	32	35	38	40	42	45	48	50	
24	145,94	40	2,40	PHS 12B-1BS24X...	-	-	-	-	25	28	30	32	35	38	40	42	45	48	50	
25	152,00	40	2,45	PHS 12B-1BS25X...	-	-	-	-	25	28	30	32	35	38	40	42	45	48	50	
26	158,04	40	2,49	PHS 12B-1BS26X...	-	-	-	-	25	28	30	32	35	38	40	42	45	48	50	
27	164,09	40	2,53	PHS 12B-1BS27X...	-	-	-	-	25	28	30	32	35	38	40	42	45	48	50	
28	170,13	40	2,57	PHS 12B-1BS28X...	-	-	-	-	25	28	30	32	35	38	40	42	45	48	50	
29	176,19	40	2,61	PHS 12B-1BS29X...	-	-	-	-	25	28	30	32	35	38	40	42	45	48	50	
30	182,25	40	2,65	PHS 12B-1BS30X...	-	-	-	-	25	28	30	32	35	38	40	42	45	48	50	

Hub diameters vary with bore size

For hardened teeth sprockets, add "H" after the sprocket profile e.g. PHS 08B-1AH8.

Type BS

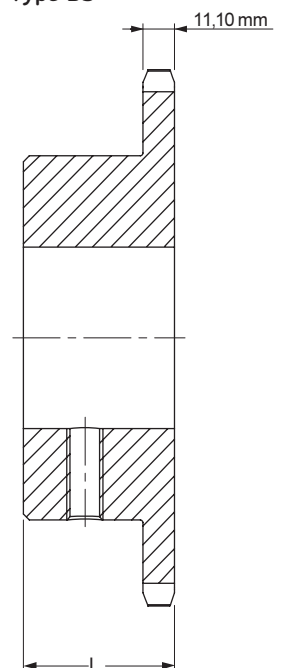

Metric sprockets



Simplex
Bored-to-size

ISO 16B-1 25,40 mm Pitch

Bored-to-size Type BS

No. Teeth	Pitch Diameter	L		Weight	Designation	Finished Bores (mm)												
		mm	mm			Includes Keyway and Setscrew												
11	90,14	40	0,82	PHS 16B-1BS11X...	25	28	30	32	35	38	40	42	-	-	-	-	-	-
12	98,14	40	1,36	PHS 16B-1BS12X...	25	28	30	32	35	38	40	42	-	-	-	-	-	-
13	106,12	40	1,59	PHS 16B-1BS13X...	25	28	30	32	35	38	40	42	45	48	50	-	-	-
14	114,15	40	1,86	PHS 16B-1BS14X...	25	28	30	32	35	38	40	42	45	48	50	-	-	-
15	122,17	40	2,36	PHS 16B-1BS15X...	25	28	30	32	35	38	40	42	45	48	50	-	-	-
16	130,20	45	2,49	PHS 16B-1BS16X...	25	28	30	32	35	38	40	42	45	48	50	-	-	-
17	138,22	45	2,72	PHS 16B-1BS17X...	25	28	30	32	35	38	40	42	45	48	50	-	-	-
18	146,28	45	2,95	PHS 16B-1BS18X...	25	28	30	32	35	38	40	42	45	48	50	-	-	-
19	154,33	45	3,18	PHS 16B-1BS19X...	25	28	30	32	35	38	40	42	45	48	50	-	-	-
20	162,38	45	3,63	PHS 16B-1BS20X...	25	28	30	32	35	38	40	42	45	48	50	-	-	-
21	170,43	45	4,04	PHS 16B-1BS21X...	25	28	30	32	35	38	40	42	45	48	50	-	-	-
22	178,48	45	4,31	PHS 16B-1BS22X...	25	28	30	32	35	38	40	42	45	48	50	-	-	-
23	186,53	50	4,63	PHS 16B-1BS23X...	25	28	30	32	35	38	40	42	45	48	50	-	-	-
24	194,59	50	4,90	PHS 16B-1BS24X...	25	28	30	32	35	38	40	42	45	48	50	-	-	-
25	202,66	50	5,17	PHS 16B-1BS25X...	25	28	30	32	35	38	40	42	45	48	50	-	-	-
26	210,72	50	5,44	PHS 16B-1BS26X...	25	28	30	32	35	38	40	42	45	48	50	-	-	-
27	218,79	50	5,71	PHS 16B-1BS27X...	25	28	30	32	35	38	40	42	45	48	50	-	-	-
28	226,85	50	5,98	PHS 16B-1BS28X...	25	28	30	32	35	38	40	42	45	48	50	-	-	-
29	234,92	50	6,25	PHS 16B-1BS29X...	25	28	30	32	35	38	40	42	45	48	50	-	-	-
30	243,00	65	6,52	PHS 16B-1BS30X...	25	28	30	32	35	38	40	42	45	48	50	-	-	-

Hub diameters vary with bore size

For hardened teeth sprockets, add "H" after the sprocket profile e.g. PHS 08B-1AH8.

Type BS

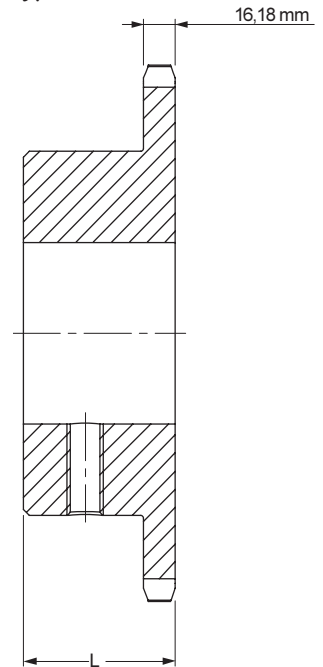

ISO 20B-1 31,75 mm Pitch

Bored-to-size Type BS

No. Teeth	Pitch Diameter	L		Weight	Designation	Finished Bores (mm)												
		mm	mm			Includes Keyway and Setscrew												
9	92,84	40	1,36	PHS 20B-1BS9X...	25	28	30	32	35	38	-	-	-	-	-	-	-	-
10	102,74	40	1,77	PHS 20B-1BS10X...	25	28	30	32	35	38	-	-	-	-	-	-	-	-
11	112,68	45	2,22	PHS 20B-1BS11X...	25	28	30	32	35	38	40	42	45	50	60	-	-	-
12	122,68	45	2,72	PHS 20B-1BS12X...	25	28	30	32	35	38	40	42	45	50	60	-	-	-
13	132,65	45	2,81	PHS 20B-1BS13X...	25	28	30	32	35	38	40	42	45	50	60	-	-	-
14	142,68	45	2,99	PHS 20B-1BS14X...	-	-	-	32	35	38	40	42	45	50	60	-	-	-
15	152,72	45	3,81	PHS 20B-1BS15X...	-	-	-	32	35	38	40	42	45	50	60	-	-	-
16	162,75	50	4,08	PHS 20B-1BS16X...	-	-	-	-	38	40	42	45	50	60	65	70	-	-
17	172,78	50	4,49	PHS 20B-1BS17X...	-	-	-	-	38	40	42	45	50	60	65	70	-	-
18	182,85	50	4,81	PHS 20B-1BS18X...	-	-	-	-	38	40	42	45	50	60	65	70	-	-
19	192,91	50	5,49	PHS 20B-1BS19X...	-	-	-	-	38	40	42	45	50	60	65	70	-	-
20	202,98	50	5,99	PHS 20B-1BS20X...	-	-	-	-	38	40	42	45	50	60	65	70	-	-

Hub diameters vary with bore size

For hardened teeth sprockets, add "H" after the sprocket profile e.g. PHS 08B-1AH8.

Type BS

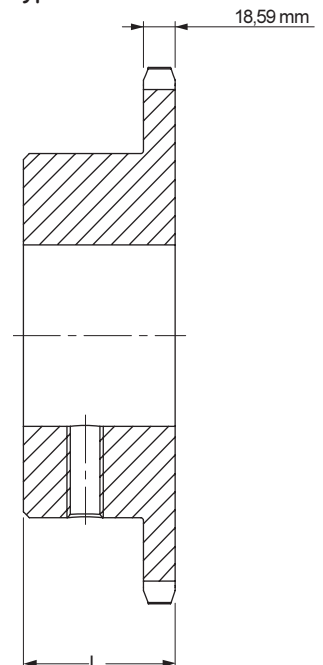



Metric sprockets

Simplex

Taper Bushed

- ▶ Belts
- ▶ Chains
- ▶ Couplings
- ▶ Bushings and Hubs
- ▶ Sprockets
- ▶ Pulleys
- ▶ Smart tools

ISO 06B-1 9,525 mm Pitch

Taper Bushed Type B

No. Teeth	Pitch Diameter	Type	Bushing Size	Bore		Dimensions		Weight		Designation
				Min	Max	L	H	Rim	Bushing	
	mm			mm	mm	mm	mm	kg	kg	
16	48,82	B	1008	9	25,4	22	42,0+	0,12	0,09	PHS 06B-1TB16
17	51,83	B	1008	9	25,4	22	45,0	0,13	0,09	PHS 06B-1TB17
18	54,85	B	1008	9	25,4	22	45,0	0,14	0,09	PHS 06B-1TB18
19	57,87	B	1008	9	25,4	22	45,0	0,16	0,09	PHS 06B-1TB19
20	60,89	B	1008	9	25,4	22	46,0	0,18	0,09	PHS 06B-1TB20
21	63,91	B	1008	9	25,4	22	46,0	0,20	0,09	PHS 06B-1TB21
22	66,93	B	1108	9	28,0	22	52,0	0,24	0,12	PHS 06B-1TB22
23	69,95	B	1210	11	31,8	25	63,0+	0,30	0,21	PHS 06B-1TB23
24	72,97	B	1210	11	31,8	25	63,0	0,32	0,21	PHS 06B-1TB24
25	76,00	B	1210	11	31,8	25	63,0	0,35	0,21	PHS 06B-1TB25
26	79,02	B	1210	11	31,8	25	63,0	0,35	0,21	PHS 06B-1TB26
27	82,05	B	1210	11	31,8	25	63,0	0,38	0,21	PHS 06B-1TB27
28	85,07	B	1210	11	31,8	25	63,0	0,38	0,21	PHS 06B-1TB28
29	88,09	B	1210	11	31,8	25	63,0	0,40	0,21	PHS 06B-1TB29
30	91,12	B	1210	11	31,8	25	63,0	0,41	0,21	PHS 06B-1TB30
32	97,18	B	1210	11	31,8	25	63,0	0,58	0,21	PHS 06B-1TB32
35	106,26	B	1210	11	31,8	25	63,0	0,76	0,21	PHS 06B-1TB35
36	109,29	B	1210	11	31,8	25	63,0	0,82	0,21	PHS 06B-1TB36
38	115,35	B	1210	11	31,8	25	70,0	0,94	0,21	PHS 06B-1TB38
40	121,40	B	1210	11	31,8	25	70,0	1,06	0,21	PHS 06B-1TB40
45	136,55	B	1210	11	31,8	25	70,0	1,36	0,21	PHS 06B-1TB45
48	145,65	B	1210	11	31,8	25	70,0	1,54	0,21	PHS 06B-1TB48
54	163,82	B	1210	11	31,8	25	70,0	1,90	0,21	PHS 06B-1TB54
57	172,90	B	1210	11	31,8	25	70,0	1,60	0,21	PHS 06B-1TB57
60	182,00	B	1210	11	31,8	25	70,0	2,26	0,21	PHS 06B-1TB60
70	212,30	B	1210	11	31,8	25	70,0	2,86	0,21	PHS 06B-1TB70
76	230,49	B	1210	11	31,8	25	70,0	2,43	0,21	PHS 06B-1TB76
95	288,08	B	1210	11	31,8	25	110,0	2,72	0,21	PHS 06B-1TB95
114	345,68	B	1215	11	31,8	25	110,0	5,50	0,31	PHS 06B-1TB114

+ Undercut in hub for chain clearance

For hardened teeth sprockets, add "H" after the sprocket profile e.g. PHS 08B-1AH8.

Type B

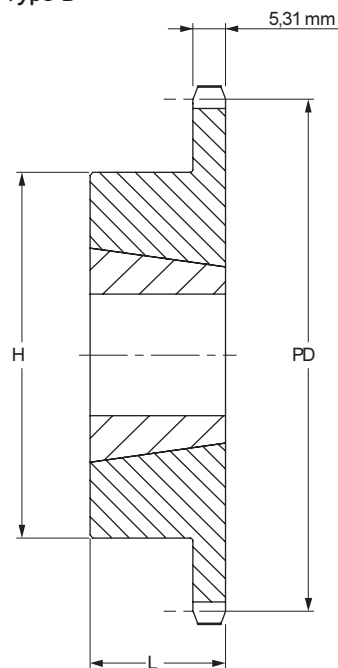

Metric sprockets



Simplex
Taper Bushed

ISO 08B-1 12,70 mm Pitch

Taper Bushed Type B

No. Teeth	Pitch Diameter	Type	Bushing Size	Bore		Dimensions		Weight		Designation
				Min	Max	L	H	Rim	Bushing	
	mm			mm	mm	mm	mm	kg	kg	
14	57,07	B	1008	9	25,4	22	46+	0,12	0,14	PHS 08B-1TB14
15	61,09	B	1008	9	25,4	22	45,0	0,18	0,14	PHS 08B-1TB15
16	65,10	B	1108	9	28,0	22	52,0	0,24	0,16	PHS 08B-1TB16
17	69,11	B	1210	11	31,8	25	60+	0,24	0,27	PHS 08B-1TB17
18	73,14	B	1210	11	31,8	25	60+	0,30	0,27	PHS 08B-1TB18
19	77,16	B	1210	11	31,8	25	63,0	0,33	0,27	PHS 08B-1TB19
20	81,19	B	1610	11	31,8	25	71,0	0,32	0,41	PHS 08B-1TB20
21	85,22	B	1610	14	41,3	25	71,0	0,37	0,41	PHS 08B-1TB21
22	89,24	B	1610	14	41,3	25	76,0	0,50	0,41	PHS 08B-1TB22
23	93,27	B	1610	14	41,3	25	76,0	0,53	0,41	PHS 08B-1TB23
24	97,29	B	1610	14	41,3	25	76,0	0,54	0,41	PHS 08B-1TB24
25	101,33	B	1610	14	41,3	25	76,0	0,59	0,41	PHS 08B-1TB25
26	105,36	B	1610	14	41,3	25	76,0	0,61	0,41	PHS 08B-1TB26
27	109,40	B	1610	14	41,3	25	76,0	0,94	0,41	PHS 08B-1TB27
28	113,42	B	2012	14	50,8	25	90,0	0,86	0,77	PHS 08B-1TB28
29	117,46	B	2012	14	50,8	25	90,0	0,90	0,77	PHS 08B-1TB29
30	121,50	B	2012	14	50,8	32	90,0	0,94	0,59	PHS 08B-1TB30
32	129,57	B	2012	14	50,8	32	90,0	1,12	0,59	PHS 08B-1TB32
35	141,68	B	2012	14	50,8	32	90,0	1,30	0,59	PHS 08B-1TB35
36	145,72	B	2012	14	50,8	32	90,0	1,48	0,59	PHS 08B-1TB36
38	153,80	B	2012	14	50,8	32	90,0	1,67	0,59	PHS 08B-1TB38
40	161,87	B	2012	14	50,8	32	90,0	1,80	0,59	PHS 08B-1TB40
42	169,94	B	2012	14	50,8	32	100,0	1,93	0,59	PHS 08B-1TB42
45	182,07	B	2012	14	50,8	32	100,0	2,06	0,59	PHS 08B-1TB45
48	194,18	B	2012	14	50,8	32	100,0	2,36	0,59	PHS 08B-1TB48
54	218,42	B	2012	14	50,8	32	100,0	2,66	0,59	PHS 08B-1TB54
57	230,53	B	2012	14	50,8	32	100,0	3,07	0,59	PHS 08B-1TB57
60	242,66	B	2012	14	50,8	32	100,0	3,23	0,59	PHS 08B-1TB60
70	283,07	B	2012	14	50,8	32	100,0	3,39	0,59	PHS 08B-1TB70
72	291,15	B	2012	14	50,8	32	100,0	3,55	0,59	PHS 08B-1TB72
76	307,31	B	2012	14	50,8	32	100,0	3,71	0,59	PHS 08B-1TB76
80	323,49	B	2012	14	50,8	32	100,0	4,55	0,59	PHS 08B-1TB80
84	339,65	B	2012	14	50,8	32	100,0	5,39	0,59	PHS 08B-1TB84
95	384,10	B	2012	14	50,8	32	100,0	6,23	0,59	PHS 08B-1TB95
96	388,15	B	2012	14	50,8	32	100,0	7,00	0,59	PHS 08B-1TB96
114	460,90	B	2517	16	63,5	45	110,0	8,10	1,30	PHS 08B-1TB114

+ Undercut in hub for chain clearance

For hardened teeth sprockets, add "H" after the sprocket profile e.g. PHS 08B-1AH8.

Type B

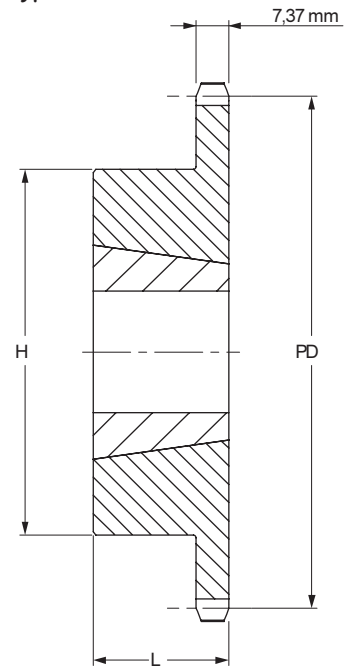



Metric sprockets

Simplex

Taper Bushed

- ▶ Belts
- ▶ Chains
- ▶ Couplings
- ▶ Bushings and Hubs
- ▶ Sprockets
- ▶ Pulleys
- ▶ Smart tools

ISO 10B-1 15,88 mm Pitch

Taper Bushed Type B

No. Teeth	Pitch Diameter	Type	Bushing Size	Bore		Dimensions		Weight		Designation
				Min	Max	L	H	Rim	Bushing	
	mm			mm	mm	mm	mm	kg	kg	
12	61,34	B	1008	9	25,4	22	49,2+	0,21	0,09	PHS 10B-1TB12
13	66,32	B	1008	9	25,4	22	47,0	0,25	0,09	PHS 10B-1TB13
14	71,34	B	1108	9	25,4	22	52,0	0,27	0,12	PHS 10B-1TB14
15	76,36	B	1210	11	31,8	25	60,0	0,33	0,21	PHS 10B-1TB15
16	81,37	B	1610	14	41,3	25	70,6+	0,32	0,31	PHS 10B-1TB16
17	86,39	B	1610	14	41,3	25	71,0+	0,40	0,31	PHS 10B-1TB17
18	91,42	B	1610	14	41,3	25	75,0	0,50	0,31	PHS 10B-1TB18
19	96,45	B	1610	14	41,3	25	75,0	0,56	0,31	PHS 10B-1TB19
20	101,49	B	1610	14	41,3	25	76,0	0,64	0,31	PHS 10B-1TB20
21	106,52	B	1610	14	41,3	25	76,0	0,69	0,31	PHS 10B-1TB21
22	111,55	B	1610	14	41,3	25	76,0	0,75	0,31	PHS 10B-1TB22
23	116,58	B	1610	14	41,3	25	76,0	0,81	0,31	PHS 10B-1TB23
24	121,62	B	2012	14	50,8	32	90,0	1,00	0,59	PHS 10B-1TB24
25	126,66	B	2012	14	50,8	32	90,0	1,06	0,59	PHS 10B-1TB25
26	131,70	B	2012	14	50,8	32	90,0	1,14	0,59	PHS 10B-1TB26
27	136,75	B	2012	14	50,8	32	90,0	1,19	0,59	PHS 10B-1TB27
28	141,78	B	2012	14	50,8	32	90,0	1,28	0,59	PHS 10B-1TB28
29	146,83	B	2012	14	50,8	32	90,0	1,37	0,59	PHS 10B-1TB29
30	151,87	B	2012	14	50,8	32	90,0	1,65	0,59	PHS 10B-1TB30
32	161,96	B	2012	14	50,8	32	98,0	2,21	0,59	PHS 10B-1TB32
35	177,10	B	2012	14	50,8	32	98,0	3,05	0,59	PHS 10B-1TB35
36	182,15	B	2012	14	50,8	32	98,0	3,33	0,59	PHS 10B-1TB36
38	192,24	B	2012	14	50,8	32	100,0	3,89	0,59	PHS 10B-1TB38
40	202,33	B	2012	14	50,8	32	100,0	4,45	0,59	PHS 10B-1TB40
42	212,43	B	2012	14	50,8	32	100,0	5,01	0,59	PHS 10B-1TB42
45	227,58	B	2012	14	50,8	32	100,0	3,97	0,59	PHS 10B-1TB45
48	242,73	B	2012	14	50,8	32	100,0	6,69	0,59	PHS 10B-1TB48
54	273,03	B	2012	14	50,8	32	100,0	8,37	0,59	PHS 10B-1TB54
57	288,19	B	2012	14	50,8	32	100,0	5,45	0,59	PHS 10B-1TB57
60	303,33	B	2012	14	50,8	32	100,0	10,05	0,59	PHS 10B-1TB60
70	353,84	B	2012	16	63,5	45	100,0	12,85	1,30	PHS 10B-1TB70
72	363,95	B	2012	16	63,5	45	100,0	13,41	1,30	PHS 10B-1TB72
76	384,15	B	2012	14	50,8	45	100,0	7,43	0,59	PHS 10B-1TB76
80	404,35	B	2012	16	63,5	45	110,0	15,65	1,30	PHS 10B-1TB80
84	424,70	B	2012	16	63,5	45	110,0	16,77	1,30	PHS 10B-1TB84
95	480,14	B	2517	14	50,8	45	110,0	19,85	0,59	PHS 10B-1TB95
96	485,30	B	2517	16	63,5	45	110,0	20,13	1,30	PHS 10B-1TB96
114	576,13	B	2517	16	63,5	45	110,0	25,17	1,30	PHS 10B-1TB114

+ Undercut in hub for chain clearance

For hardened teeth sprockets, add "H" after the sprocket profile e.g. PHS 08B-1AH8.

Type B

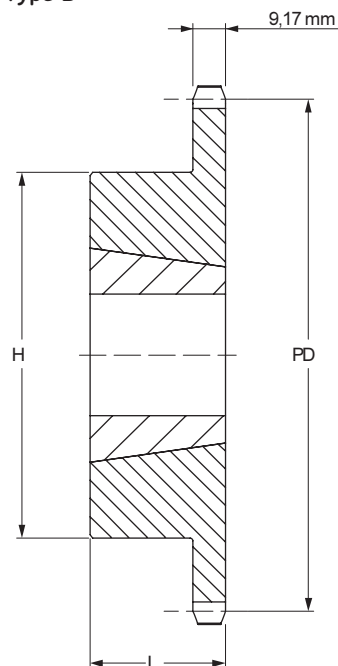

Metric sprockets

Simplex
Taper Bushed



ISO 12B-1 19,05 mm Pitch

Taper Bushed Type B

No. Teeth	Pitch Diameter	Type	Bushing Size	Bore		Dimensions		Weight		Designation
				Min	Max	L	H	Rim	Bushing	
	mm			mm	mm	mm	mm	kg	kg	
11	67,61	B	1008	9	25,4	22	46,0	0,22	0,09	PHS 12B-1TB11
12	73,61	B	1008	9	25,4	22	49,2	0,30	0,09	PHS 12B-1TB12
13	79,59	B	1210	11	31,8	25	60,0	0,38	0,21	PHS 12B-1TB13
14	85,61	B	1610	14	41,3	25	70,0	0,46	0,31	PHS 12B-1TB14
15	91,63	B	1610	14	41,3	25	70,0	0,48	0,31	PHS 12B-1TB15
16	97,65	B	1610	14	41,3	25	75,0	0,60	0,31	PHS 12B-1TB16
17	103,67	B	1610	14	41,3	25	76,0	0,70	0,31	PHS 12B-1TB17
18	109,71	B	2012	14	50,8	32	90,0	0,86	0,59	PHS 12B-1TB18
19	115,75	B	2012	14	50,8	32	90,0	0,98	0,59	PHS 12B-1TB19
20	121,78	B	2012	14	50,8	32	95,0	1,25	0,59	PHS 12B-1TB20
21	127,82	B	2517	16	63,5	45	102,0	1,28	1,30	PHS 12B-1TB21
22	133,86	B	2517	16	63,5	45	102,0	1,37	1,30	PHS 12B-1TB22
23	139,90	B	2517	16	63,5	45	108,0	1,75	1,30	PHS 12B-1TB23
24	145,94	B	2517	16	63,5	45	108,0	1,85	1,30	PHS 12B-1TB24
25	152,00	B	2517	16	63,5	45	108,0	1,95	1,30	PHS 12B-1TB25
26	158,04	B	2517	16	63,5	45	108,0	2,09	1,30	PHS 12B-1TB26
27	164,09	B	2517	16	63,5	45	108,0	2,22	1,30	PHS 12B-1TB27
28	170,13	B	2517	16	63,5	45	108,0	2,36	1,30	PHS 12B-1TB28
29	176,19	B	2517	16	63,5	45	108,0	2,75	1,30	PHS 12B-1TB29
30	182,25	B	2517	16	63,5	45	108,0	2,89	1,30	PHS 12B-1TB30
32	194,36	B	2517	16	63,5	45	108,0	3,59	1,30	PHS 12B-1TB32
35	212,52	B	2517	16	63,5	45	108,0	4,41	1,30	PHS 12B-1TB35
36	218,58	B	2517	16	63,5	45	108,0	4,68	1,30	PHS 12B-1TB36
38	230,69	B	2517	16	63,5	45	108,0	4,60	1,30	PHS 12B-1TB38
40	242,81	B	2517	16	63,5	45	108,0	5,78	1,30	PHS 12B-1TB40
42	254,93	B	2517	16	63,5	45	108,0	6,33	1,30	PHS 12B-1TB42
45	273,10	B	2517	16	63,5	45	108,0	5,70	1,30	PHS 12B-1TB45
48	291,27	B	2517	16	63,5	45	108,0	7,97	1,30	PHS 12B-1TB48
54	327,64	B	2517	16	63,5	45	108,0	9,61	1,30	PHS 12B-1TB54
57	345,81	B	2517	16	63,5	45	108,0	6,49	1,30	PHS 12B-1TB57
60	363,99	B	2517	16	63,5	45	108,0	11,25	1,30	PHS 12B-1TB60
68	412,49	B	2517	16	63,5	45	108,0	13,44	1,30	PHS 12B-1TB68
70	424,60	B	2517	16	63,5	45	108,0	13,99	1,30	PHS 12B-1TB70
72	436,74	B	2517	16	63,5	45	108,0	14,54	1,30	PHS 12B-1TB72
76	460,99	B	2517	16	63,5	45	108,0	11,20	1,30	PHS 12B-1TB76
84	509,48	B	2517	16	63,5	45	108,0	17,82	1,30	PHS 12B-1TB84
95	576,17	B	2517	16	63,5	45	108,0	17,64	1,30	PHS 12B-1TB95
96	582,23	B	2517	16	63,5	45	108,0	21,11	1,30	PHS 12B-1TB96
114	691,36	B	2517	16	63,5	64	108,0	26,04	1,30	PHS 12B-1TB114

For hardened teeth sprockets, add "H" after the sprocket profile e.g. PHS 08B-1AH8.

Type B

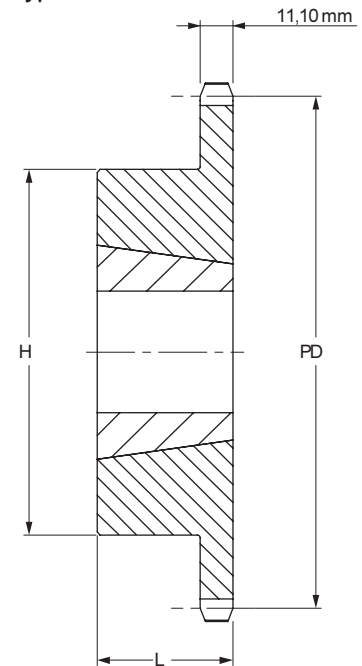



Metric sprockets

Simplex

Taper Bushed

- ▶ Belts
- ▶ Chains
- ▶ Couplings
- ▶ Bushings and Hubs
- ▶ Sprockets
- ▶ Pulleys
- ▶ Smart tools

ISO 16B-1 25,40 mm Pitch

Taper Bushed Type B

No. Teeth	Pitch Diameter mm	Type	Bushing Size	Bore		Dimensions		Weight		Designation
				Min mm	Max mm	L mm	H mm	Rim kg	Bushing kg	
10	82,19	B	1215	11	31,8	38	62,7	0,34	0,30	PHS 16B-1TB10
11	90,14	B	1215	11	31,8	38	62,7	0,57	0,30	PHS 16B-1TB11
12	98,14	B	1615	14	41,3	38	76,2	0,81	0,43	PHS 16B-1TB12
13	106,12	B	1615	14	41,3	38	73,0	1,03	0,43	PHS 16B-1TB13
14	114,15	B	1615	14	41,3	38	78,0	1,26	0,43	PHS 16B-1TB14
15	122,17	B	1615	14	41,3	38	76,0	1,40	0,43	PHS 16B-1TB15
16	130,20	B	2012	14	50,8	32	90,0	1,42	0,59	PHS 16B-1TB16
17	138,22	B	2012	14	50,8	32	90,0	1,60	0,59	PHS 16B-1TB17
18	146,28	B	2517	16	63,5	32	108,0	2,09	1,30	PHS 16B-1TB18
19	154,33	B	2517	16	63,5	45	108,0	2,30	1,30	PHS 16B-1TB19
20	162,38	B	2517	16	63,5	45	110,0	2,56	1,30	PHS 16B-1TB20
21	170,43	B	2517	16	63,5	45	110,0	2,80	1,30	PHS 16B-1TB21
22	178,48	B	2517	16	63,5	45	110,0	3,36	1,30	PHS 16B-1TB22
23	186,53	B	2517	16	63,5	45	110,0	3,34	1,30	PHS 16B-1TB23
24	194,59	B	2517	16	63,5	45	110,0	3,66	1,30	PHS 16B-1TB24
25	202,66	B	2517	16	63,5	45	110,0	3,96	1,30	PHS 16B-1TB25
26	210,72	B	2517	16	63,5	45	110,0	4,26	1,30	PHS 16B-1TB26
27	218,79	B	2517	16	63,5	45	110,0	4,63	1,30	PHS 16B-1TB27
28	226,85	B	2517	16	63,5	45	140,0	4,97	1,30	PHS 16B-1TB28
29	234,92	B	3020	25	76,2	51	140,0	6,24	2,24	PHS 16B-1TB29
30	243,00	B	3020	25	76,2	51	140,0	6,67	2,24	PHS 16B-1TB30
32	259,13	B	3020	25	76,2	51	140,0	8,37	2,24	PHS 16B-1TB32
35	283,36	B	3020	25	76,2	51	140,0	10,92	2,24	PHS 16B-1TB35
36	291,44	B	3020	25	76,2	51	140,0	11,77	2,24	PHS 16B-1TB36
38	307,59	B	3020	25	76,2	51	140,0	9,49	2,24	PHS 16B-1TB38
40	323,75	B	3020	25	76,2	51	140,0	15,17	2,24	PHS 16B-1TB40
45	364,13	B	3020	25	76,2	51	140,0	11,70	2,24	PHS 16B-1TB45
48	388,36	B	3020	25	76,2	51	140,0	18,91	2,24	PHS 16B-1TB48
54	436,85	B	3020	25	76,2	51	140,0	21,72	2,24	PHS 16B-1TB54
57	461,07	B	3020	25	76,2	51	140,0	15,00	2,24	PHS 16B-1TB57
60	485,32	B	3020	25	76,2	51	140,0	24,52	2,24	PHS 16B-1TB60
64	517,65	B	3020	25	76,2	51	140,0	26,39	2,24	PHS 16B-1TB64
70	566,14	B	3020	25	76,2	51	140,0	29,20	2,24	PHS 16B-1TB70
76	614,65	B	3020	25	76,2	51	140,0	23,00	2,24	PHS 16B-1TB76
80	646,96	B	3020	25	76,2	51	140,0	33,87	2,24	PHS 16B-1TB80
84	679,30	B	3020	25	76,2	51	140,0	35,74	2,24	PHS 16B-1TB84
95	768,22	B	3020	25	76,2	51	140,0	40,88	2,24	PHS 16B-1TB95
114	921,81	B	3020	25	76,2	76	140,0	49,77	2,24	PHS 16B-1TB114

For hardened teeth sprockets, add "H" after the sprocket profile e.g. PHS 08B-1AH8.

Type B

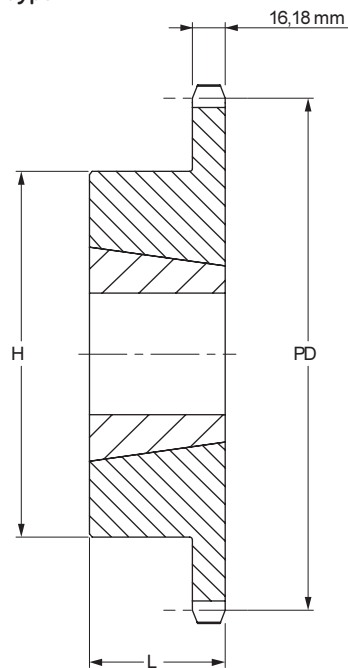



Metric sprockets



Simplex
Taper Bushed

ISO 20B-1 31,75 mm Pitch

Taper Bushed Type B/C

No. Teeth	Pitch Diameter	Type	Bushing Size	Bore		Dimensions		Weight		Designation
				Min	Max	L	H	Rim	Bushing	
	mm			mm	mm	mm	mm	kg	kg	
11	112,70	B	1615	14	41,3	38	62,7	1,22	0,43	PHS 20B-1TB11
12	122,67	B	1615	14	41,3	38	70,6	1,41	0,43	PHS 20B-1TB12
13	132,67	B	2012	14	50,8	32	90,0	1,45	0,59	PHS 20B-1TB13
14	142,68	B	2012	14	50,8	32	90,5	1,63	0,59	PHS 20B-1TB14
15	152,71	B	2517	16	63,5	45	108,0	2,31	1,30	PHS 20B-1TB15
16	162,75	B	2517	16	63,5	45	108,0	2,72	1,30	PHS 20B-1TB16
17	172,79	B	2517	16	63,5	45	108,0	3,27	1,30	PHS 20B-1TB17
18	182,84	B	2517	16	63,5	45	108,0	3,63	1,30	PHS 20B-1TB18
19	192,90	B	2517	16	63,5	45	108,0	4,09	1,30	PHS 20B-1TB19
20	202,96	B	2517	16	63,5	45	108,0	4,40	1,30	PHS 20B-1TB20
21	213,03	B	2517	16	63,5	45	108,0	4,54	1,30	PHS 20B-1TB21
22	223,10	B	2517	16	63,5	45	108,0	4,77	1,30	PHS 20B-1TB22
23	233,17	B	2517	16	63,5	45	108,0	5,58	1,30	PHS 20B-1TB23
24	243,25	B	2517	16	63,5	45	108,0	6,13	1,30	PHS 20B-1TB24
25	253,32	B	2517	16	63,5	45	108,0	6,95	1,30	PHS 20B-1TB25
26	263,41	B	2517	16	63,5	51	108,0	7,35	1,30	PHS 20B-1TB26
28	283,57	B	3020	25	76,2	51	150,0	7,90	2,24	PHS 20B-1TB28
30	303,75	B	3020	25	76,2	51	150,0	9,62	2,24	PHS 20B-1TB30
32	323,92	B	3020	25	76,2	51	160,0	11,03	2,24	PHS 20B-1TB32
35	354,20	B	3020	25	76,2	51	160,0	13,15	2,24	PHS 20B-1TB35
36	364,29	B	3020	25	76,2	51	160,0	13,86	2,24	PHS 20B-1TB36
38	384,48	B	3020	25	76,2	51	160,0	15,98	2,24	PHS 20B-1TB38
40	404,67	B	3020	25	76,2	51	160,0	19,43	2,24	PHS 20B-1TB40
45	455,15	B	3020	25	76,2	51	160,0	25,18	2,24	PHS 20B-1TB45
48	485,45	B	3020	25	76,2	51	160,0	28,62	2,24	PHS 20B-1TB48
54	546,05	B	3020	25	76,2	51	160,0	35,52	2,24	PHS 20B-1TB54
57	576,35	B	3020	25	76,2	51	160,0	37,82	2,24	PHS 20B-1TB57
60	606,66	B	3020	25	76,2	51	160,0	41,27	2,24	PHS 20B-1TB60
70	707,68	C	3535	35	88,9	51	160,0	51,56	5,18	PHS 20B-1TB70
72	727,89	C	3535	35	88,9	51	160,0	53,97	5,18	PHS 20B-1TB72
76	768,30	C	3535	35	88,9	51	160,0	60,33	5,18	PHS 20B-1TB76
80	808,71	C	3535	35	88,9	51	160,0	66,23	5,18	PHS 20B-1TB80
84	849,13	C	3535	35	88,9	51	160,0	73,48	5,18	PHS 20B-1TB84
90	909,76	C	3535	35	88,9	51	160,0	94,33	5,18	PHS 20B-1TB90
95	960,28	C	3535	35	88,9	51	160,0	96,16	5,18	PHS 20B-1TB95

For hardened teeth sprockets, add "H" after the sprocket profile e.g. PHS 08B-1AH8.

Type B

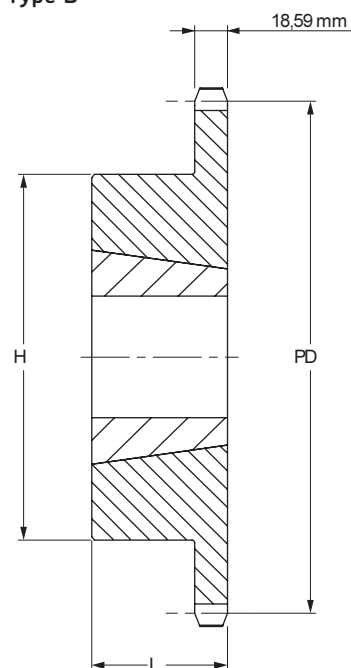

Type C

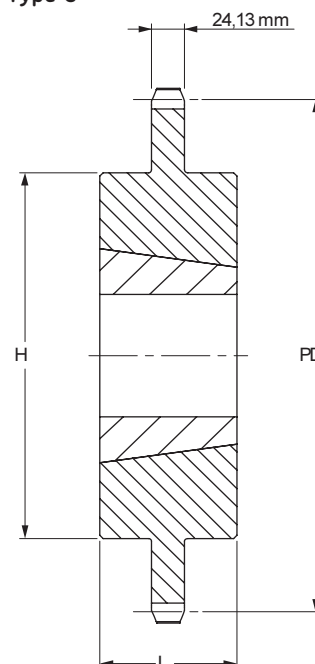



Metric sprockets

Simplex

Taper Bushed

- ▶ Belts
- ▶ Chains
- ▶ Couplings
- ▶ Bushings and Hubs
- ▶ Sprockets
- ▶ Pulleys
- ▶ Smart tools

ISO 24B-1 38,10 mm Pitch

Taper Bushed Type B/C

No. Teeth	Pitch Diameter	Type	Bushing Size	Bore		Dimensions		Weight		Designation
				Min	Max	L	H	Rim	Bushing	
	mm			mm	mm	mm	mm	kg	kg	
11	135,23	B	2012	14	50,8	31,8	90,5	2,28	0,59	PHS 24B-1TB11
12	147,21	B	2012	14	50,8	31,8	90,5	2,49	0,59	PHS 24B-1TB12
13	159,20	B	2517	16	63,5	44,5	107,9	2,77	1,30	PHS 24B-1TB13
14	171,22	B	2517	16	63,5	44,5	107,9	3,54	1,30	PHS 24B-1TB14
15	183,25	B	2517	16	63,5	44,5	107,9	4,31	1,30	PHS 24B-1TB15
16	195,29	B	3020	25	76,2	50,8	133,4	4,77	2,24	PHS 24B-1TB16
17	207,35	B	3020	25	76,2	50,8	133,4	5,45	2,24	PHS 24B-1TB17
18	219,41	B	3020	25	76,2	50,8	133,4	6,13	2,24	PHS 24B-1TB18
19	231,48	B	3020	25	76,2	50,8	133,4	6,81	2,24	PHS 24B-1TB19
20	243,55	B	3020	25	76,2	50,8	133,4	7,49	2,24	PHS 24B-1TB20
21	255,63	B	3020	25	76,2	50,8	133,4	7,94	2,24	PHS 24B-1TB21
22	267,72	B	3020	25	76,2	50,8	133,4	8,75	2,24	PHS 24B-1TB22
23	279,80	B	3020	25	76,2	50,8	133,4	9,53	2,24	PHS 24B-1TB23
24	291,90	B	3020	25	76,2	50,8	133,4	10,67	2,24	PHS 24B-1TB24
25	303,99	B	3020	25	76,2	50,8	133,4	11,80	2,24	PHS 24B-1TB25
26	316,09	B	3020	25	76,2	50,8	133,4	12,93	2,24	PHS 24B-1TB26
27	328,19	B	3020	25	76,2	50,8	133,4	13,50	2,24	PHS 24B-1TB27
28	340,29	B	3020	25	76,2	50,8	133,4	14,70	2,24	PHS 24B-1TB28
29	352,29	B	3020	25	76,2	50,8	133,4	14,75	2,24	PHS 24B-1TB29
30	364,49	B	3020	25	76,2	50,8	133,4	15,20	2,24	PHS 24B-1TB30
32	388,71	B	3020	25	76,2	50,8	133,4	15,76	2,24	PHS 24B-1TB32
38	461,37	B	3030	35	76,2	76,2	139,7	24,97	3,04	PHS 24B-1TB38
40	485,60	C	3030	35	76,2	76,2	139,7	28,46	3,04	PHS 24B-1TB40
42	509,83	C	3030	35	76,2	76,2	139,7	31,95	3,04	PHS 24B-1TB42
45	546,19	C	3030	35	76,2	76,2	139,7	37,19	3,04	PHS 24B-1TB45
48	582,54	C	3030	35	76,2	76,2	139,7	42,43	3,04	PHS 24B-1TB48
50	606,78	C	3030	35	76,2	76,2	139,7	45,92	3,04	PHS 24B-1TB50
54	655,26	C	3535	35	88,9	88,9	165,1	63,32	5,18	PHS 24B-1TB54
57	691,62	C	3535	35	88,9	88,9	165,1	71,46	5,18	PHS 24B-1TB57
60	727,99	C	3535	35	88,9	88,9	165,1	79,60	5,18	PHS 24B-1TB60
68	824,97	C	3535	35	88,9	88,9	165,1	101,31	5,18	PHS 24B-1TB68
72	873,46	C	3535	35	88,9	88,9	165,1	112,17	5,18	PHS 24B-1TB72
76	921,96	C	3535	35	88,9	88,9	165,1	123,02	5,18	PHS 24B-1TB76
95	1152,33	C	4040	40	101,6	101,6	196,9	196,67	8,27	PHS 24B-1TB95
96	1164,46	C	4040	40	101,6	101,6	196,9	201,03	8,27	PHS 24B-1TB96
114	1382,72	C	4040	40	101,6	101,6	196,9	279,50	8,27	PHS 24B-1TB114

For hardened teeth sprockets, add "H" after the sprocket profile e.g. PHS 08B-1AH8.

Type B

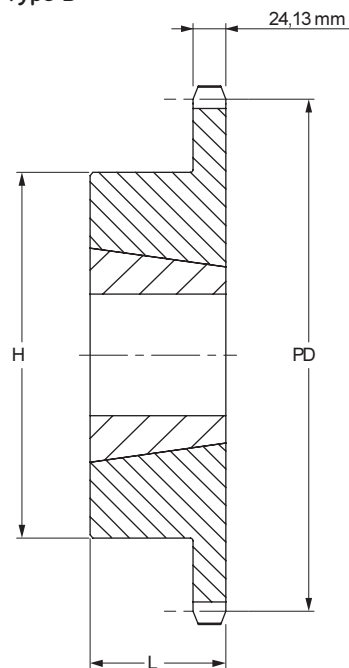

Type C

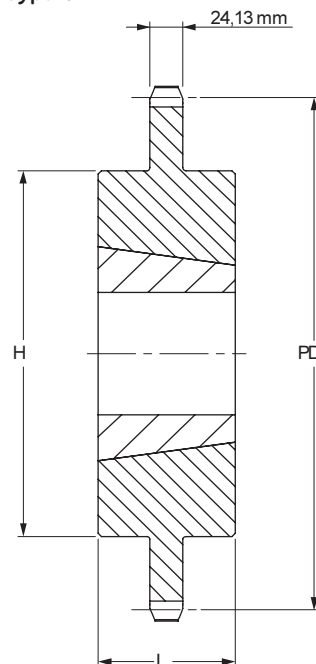

Metric sprockets



Simplex
Taper Bushed

ISO 28B-1 44,45 mm Pitch

Taper Bushed Type B/C

No. Teeth	Pitch Diameter	Type	Bushing Size	Bore		Dimensions		Weight		Designation
				Min	Max	L	H	Rim	Bushing	
	mm			mm	mm	mm	mm	kg	kg	
11	157,77	B	2517	16	63,5	44,5	107,9	3,53	1,30	PHS 28B-1TB11
12	171,74	B	2517	16	63,5	44,5	107,9	3,86	1,30	PHS 28B-1TB12
13	185,75	B	3020	25	76,2	50,8	133,4	5,90	2,24	PHS 28B-1TB13
14	199,76	B	3020	25	76,2	50,8	133,4	7,04	2,24	PHS 28B-1TB14
15	213,79	B	3020	25	76,2	50,8	133,4	8,17	2,24	PHS 28B-1TB15
16	227,84	B	3020	25	76,2	50,8	133,4	9,76	2,24	PHS 28B-1TB16
17	241,91	B	3020	25	76,2	50,8	133,4	11,35	2,24	PHS 28B-1TB17
18	255,98	B	3020	25	76,2	50,8	133,4	12,49	2,24	PHS 28B-1TB18
19	270,06	B	3020	25	76,2	50,8	133,4	13,62	2,24	PHS 28B-1TB19
20	284,15	B	3020	25	76,2	50,8	133,4	14,30	2,24	PHS 28B-1TB20
21	298,24	B	3020	25	76,2	50,8	133,4	14,98	2,24	PHS 28B-1TB21
22	312,34	B	3020	25	76,2	50,8	133,4	16,91	2,24	PHS 28B-1TB22
23	326,44	B	3020	25	76,2	50,8	133,4	18,84	2,24	PHS 28B-1TB23
24	340,55	B	3020	25	76,2	50,8	133,4	20,77	2,24	PHS 28B-1TB24
25	354,66	B	3020	25	76,2	50,8	133,4	22,70	2,24	PHS 28B-1TB25
26	368,77	B	3020	25	76,2	50,8	133,4	24,63	2,24	PHS 28B-1TB26
27	382,88	B	3020	25	76,2	50,8	133,4	26,56	2,24	PHS 28B-1TB27
28	397,00	B	3020	25	76,2	50,8	133,4	28,49	2,24	PHS 28B-1TB28
30	425,24	B	3020	25	76,2	50,8	133,4	32,35	2,24	PHS 28B-1TB30
32	453,49	B	3020	25	76,2	50,8	133,4	36,21	2,24	PHS 28B-1TB32
38	538,27	B	3535	35	88,9	88,9	165,1	45,40	3,56	PHS 28B-1TB38
40	566,54	C	3535	35	88,9	88,9	165,1	47,79	3,56	PHS 28B-1TB40
42	594,82	C	3535	35	88,9	88,9	165,1	50,18	3,56	PHS 28B-1TB42
45	637,22	C	4040	40	101,6	101,6	219,1	57,35	8,27	PHS 28B-1TB45
48	679,63	C	4040	40	101,6	101,6	219,1	61,17	8,27	PHS 28B-1TB48
54	764,46	C	4040	40	101,6	101,6	219,1	68,82	8,27	PHS 28B-1TB54
57	806,90	C	4040	40	101,6	101,6	219,1	72,64	8,27	PHS 28B-1TB57
60	849,32	C	4040	40	101,6	101,6	219,1	76,44	8,27	PHS 28B-1TB60
68	962,46	C	4040	40	101,6	101,6	219,1	86,63	8,27	PHS 28B-1TB68
72	1019,05	C	4040	40	101,6	101,6	219,1	91,73	8,27	PHS 28B-1TB72
76	1075,62	C	4040	40	101,6	101,6	219,1	96,83	8,27	PHS 28B-1TB76
95	1344,37	C	4040	40	101,6	101,6	219,1	121,03	8,27	PHS 28B-1TB95

For hardened teeth sprockets, add "H" after the sprocket profile e.g. PHS 08B-1AH8.

Type B

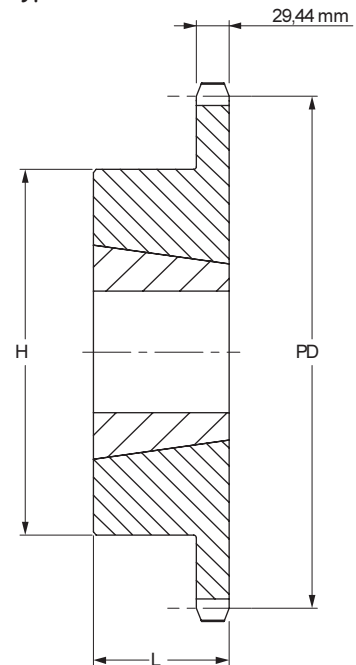

Type C

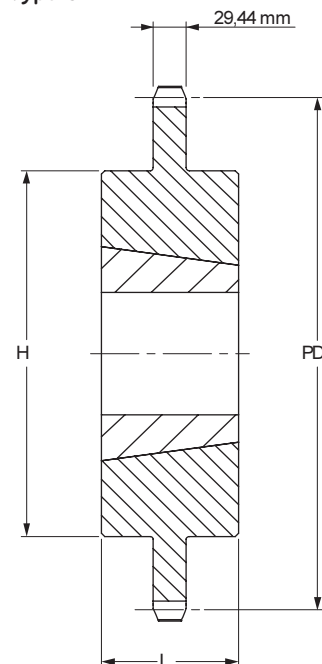



Metric sprockets

Simplex

Taper Bushed

- ▶ Belts
- ▶ Chains
- ▶ Couplings
- ▶ Bushings and Hubs
- ▶ Sprockets
- ▶ Pulleys
- ▶ Smart tools

ISO 32B-1 50,80 mm Pitch

Taper Bushed Type B/C

No. Teeth	Pitch Diameter	Type	Bushing Size	Bore		Dimensions		Weight		Designation
				Min	Max	L	H	Rim	Bushing	
	mm			mm	mm	mm	mm	kg	kg	
11	180,34	B	2517	16	63,5	44,5	107,9	4,51	1,30	PHS 32B-1TB11
12	196,29	B	3020	25	76,2	50,8	133,4	5,27	2,24	PHS 32B-1TB12
13	212,29	B	3020	25	76,2	50,8	133,4	6,38	2,24	PHS 32B-1TB13
14	228,29	B	3020	25	76,2	50,8	133,4	6,87	2,24	PHS 32B-1TB14
15	244,30	B	3535	35	88,9	88,9	165,1	11,80	5,18	PHS 32B-1TB15
16	260,40	B	3535	35	88,9	88,9	165,1	13,38	5,18	PHS 32B-1TB16
17	276,40	B	3535	35	88,9	88,9	165,1	14,98	5,18	PHS 32B-1TB17
18	292,55	B	3535	35	88,9	88,9	165,1	16,12	5,18	PHS 32B-1TB18
19	308,66	B	3535	35	88,9	88,9	165,1	17,25	5,18	PHS 32B-1TB19
20	324,71	B	3535	35	88,9	88,9	165,1	21,10	5,18	PHS 32B-1TB20
21	340,82	B	3535	35	88,9	88,9	165,1	24,94	5,18	PHS 32B-1TB21
22	356,98	B	3535	35	88,9	88,9	165,1	27,79	5,18	PHS 32B-1TB22
23	373,08	B	3535	35	88,9	88,9	165,1	30,64	5,18	PHS 32B-1TB23
24	389,18	B	3535	35	88,9	88,9	165,1	33,48	5,18	PHS 32B-1TB24
25	405,33	B	3535	35	88,9	88,9	165,1	36,32	5,18	PHS 32B-1TB25
26	421,44	B	3535	35	88,9	88,9	165,1	39,16	5,18	PHS 32B-1TB26
27	437,59	B	3535	35	88,9	88,9	165,1	42,00	5,18	PHS 32B-1TB27
28	453,69	B	3535	35	88,9	88,9	165,1	44,84	5,18	PHS 32B-1TB28
30	486,00	B	3535	35	88,9	88,9	165,1	50,52	5,18	PHS 32B-1TB30
32	518,26	B	3535	35	88,9	88,9	165,1	56,20	5,18	PHS 32B-1TB32
38	615,14	B	4040	40	101,6	101,6	219,1	68,10	8,27	PHS 32B-1TB38
40	647,49	C	4040	40	101,6	101,6	219,1	77,08	8,27	PHS 32B-1TB40
45	728,26	C	4040	40	101,6	101,6	219,1	99,53	8,27	PHS 32B-1TB45
48	776,72	C	4040	40	101,6	101,6	219,1	113,01	8,27	PHS 32B-1TB48
54	873,68	C	4040	40	101,6	114,3	219,1	139,95	8,27	PHS 32B-1TB54
57	922,17	C	4545	55	114,3	114,3	247,7	136,20	9,99	PHS 32B-1TB57
60	970,63	C	4545	55	114,3	114,3	247,7	158,84	9,99	PHS 32B-1TB60
64	1035,30	C	4545	55	114,3	114,3	247,7	189,03	9,99	PHS 32B-1TB64
70	1132,29	C	4545	55	114,3	114,3	247,7	234,32	9,99	PHS 32B-1TB70

For hardened teeth sprockets, add "H" after the sprocket profile e.g. PHS 08B-1AH8.

Type B

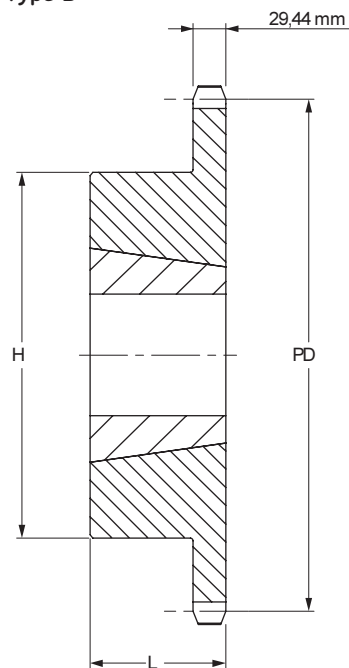

Type C

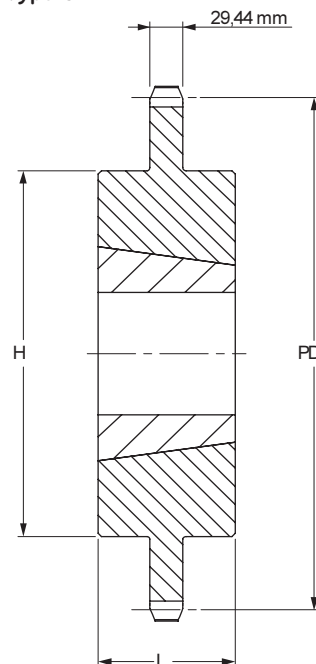



Metric sprockets

Double Simplex



ISO 06B-1 9,525 mm Pitch

Double Simplex Type A

No. Teeth	Diameters		Type	Bore		Dimensions			Weight kg	Designation
	Outside	Pitch		Min	Max	L	C	E		
14	46,3	42,80	A	10	20	25,5	20,3	31	0,17	PHS 06B-1DSA14
15	49,3	45,81	A	10	23	25,5	20,3	34	0,20	PHS 06B-1DSA15
16	52,3	48,82	A	10	25	25,5	20,3	37	0,23	PHS 06B-1DSA16
17	55,3	51,83	A	12	27	25,5	20,3	40	0,27	PHS 06B-1DSA17
18	58,3	54,85	A	12	29	25,5	20,3	43	0,30	PHS 06B-1DSA18
19	61,3	57,87	A	12	31	25,5	20,3	46	0,35	PHS 06B-1DSA19
20	64,3	60,89	A	12	33	25,5	20,3	48	0,39	PHS 06B-1DSA20
21	68,0	63,91	A	15	35	25,5	20,3	52	0,44	PHS 06B-1DSA21
22	71,0	66,93	A	15	36	25,5	20,3	55	0,50	PHS 06B-1DSA22
23	73,5	69,95	A	15	38	25,5	20,3	59	0,55	PHS 06B-1DSA23
24	77,0	72,97	A	15	40	25,5	20,3	61	0,61	PHS 06B-1DSA24
25	80,0	76,02	A	15	43	25,5	20,3	65	0,67	PHS 06B-1DSA25

For hardened teeth sprockets, add "H" after the sprocket profile e.g. PHS 08B-1AH8.

Type A

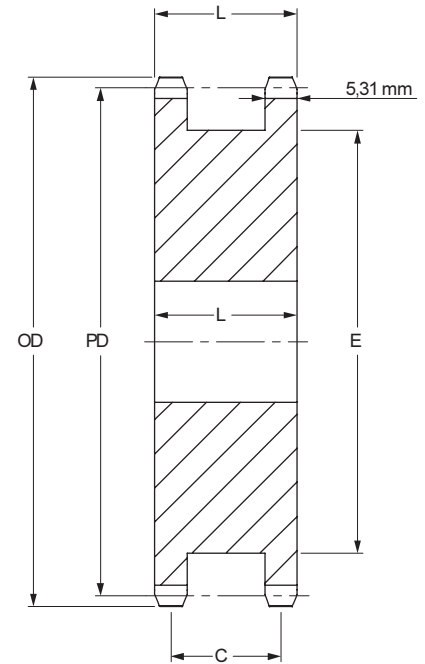

Double Simplex Taper Bushed Type A

No. Teeth	Bushing Size	Diameters		Type	Bore		Dimensions				Weight* kg	Designation
		Outside	Pitch		Min	Max	L ₁	C	E	L ₂		
18	1008	58,3	54,85	A	9	25	23,5	18,17	43	22,2	0,19	PHS 06B-1DSTB18
19	1008	61,3	57,87	A	9	25	23,5	18,17	46	22,2	0,23	PHS 06B-1DSTB19
20	1108	64,3	60,89	A	9	28	23,5	18,17	48	22,2	0,25	PHS 06B-1DSTB20
21	1108	68,0	63,91	A	9	28	23,5	18,17	52	22,2	0,31	PHS 06B-1DSTB21
22	1108	71,0	66,93	A	9	28	23,5	18,17	55	22,2	0,36	PHS 06B-1DSTB22
23	1108	73,5	69,95	A	9	28	23,5	18,17	58	22,2	0,41	PHS 06B-1DSTB23
24	1108	77,0	72,97	A	9	28	23,5	18,17	61	22,2	0,47	PHS 06B-1DSTB24
25	1108	80,0	76,02	A	9	28	23,5	18,17	64	22,2	0,53	PHS 06B-1DSTB25

* Weight for rim only

For hardened teeth sprockets, add "H" after the sprocket profile e.g. PHS 08B-1AH8.

Type A Taper Bush

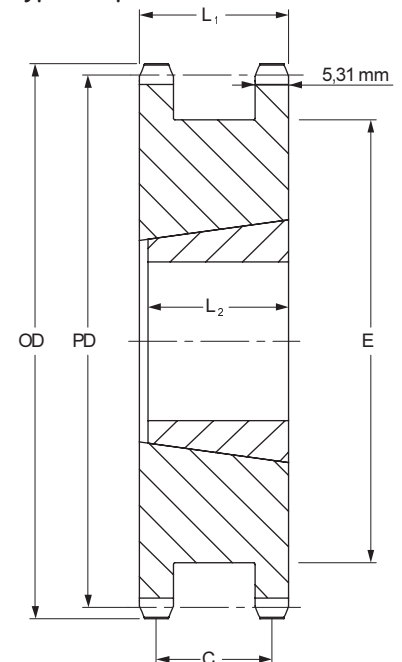

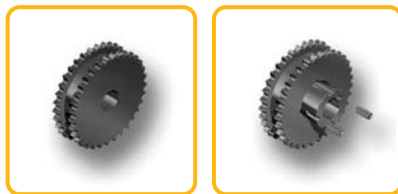

Metric sprockets

Double Simplex

- ▶ Belts
- ▶ Chains
- ▶ Couplings
- ▶ Bushings and Hubs
- ▶ Sprockets
- ▶ Pulleys
- ▶ Smart tools

ISO 08B-1 12,70 mm Pitch

Double Simplex Type A

No. Teeth	Diameters		Type	Bore		Dimensions			Weight kg	Designation
	Outside	Pitch		Min	Max	L	C	E		
12	53,0	49,07	A	10	24	32,0	24,8	35	0,35	PHS 08B-1DSA12
13	57,4	53,06	A	10	26	32,0	24,8	37	0,41	PHS 08B-1DSA13
14	61,8	57,07	A	10	27	32,0	24,8	41	0,49	PHS 08B-1DSA14
15	65,5	61,09	A	10	30	32,0	24,8	45	0,55	PHS 08B-1DSA15
16	69,5	65,10	A	12	34	32,0	24,8	50	0,64	PHS 08B-1DSA16
17	73,6	69,11	A	12	36	32,0	24,8	53	0,73	PHS 08B-1DSA17
18	77,8	73,14	A	12	38	32,0	24,8	58	0,82	PHS 08B-1DSA18
19	81,7	77,16	A	12	41	32,0	24,8	62	1,00	PHS 08B-1DSA19
20	85,8	81,18	A	12	44	32,0	24,8	66	1,18	PHS 08B-1DSA20
21	89,7	85,22	A	15	46	32,0	24,8	70	1,32	PHS 08B-1DSA21
22	93,8	89,24	A	15	48	32,0	24,8	74	1,36	PHS 08B-1DSA22
23	98,2	93,27	A	15	52	32,0	24,8	78	1,59	PHS 08B-1DSA23
24	101,8	97,29	A	15	54	32,0	24,8	82	1,70	PHS 08B-1DSA24
25	105,8	101,33	A	15	57	32,0	24,8	86	1,82	PHS 08B-1DSA25

For hardened teeth sprockets, add "H" after the sprocket profile e.g. PHS 08B-1AH8.

Type A

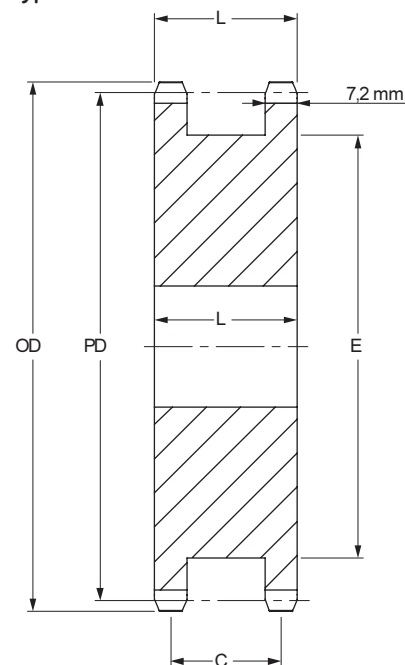

Double Simplex Taper Bushed Type A

No. Teeth	Bushing Size	Diameters		Type	Bore		Dimensions				Weight* kg	Designation
		Outside	Pitch		Min	Max	L ₁	C	E	L ₂		
14	1008	61,8	57,07	A	9	25	35,7	28,58	41	22,2	0,32	PHS 08B-1DSTB14
15	1008	65,3	61,09	A	9	25	35,7	28,58	45	22,2	0,40	PHS 08B-1DSTB15
16	1108	69,5	65,10	A	9	28	35,7	28,58	49	22,2	0,44	PHS 08B-1DSTB16
17	1215	73,6	69,11	A	11	32	35,7	28,58	53	38,1	0,43	PHS 08B-1DSTB17
18	1215	77,8	73,14	A	11	32	35,7	28,58	58	38,1	0,46	PHS 08B-1DSTB18
19	1215	81,7	77,15	A	11	32	35,7	28,58	63	38,1	0,50	PHS 08B-1DSTB19
20	1215	85,8	81,18	A	11	32	35,7	28,58	66	38,1	0,59	PHS 08B-1DSTB20
21	1615	89,7	85,22	A	14	42	35,7	28,58	70	38,1	0,59	PHS 08B-1DSTB21
22	1615	93,8	89,24	A	14	42	35,7	28,58	74	38,1	0,64	PHS 08B-1DSTB22
23	1615	98,2	93,27	A	14	42	35,7	28,58	78	38,1	0,68	PHS 08B-1DSTB23
24	1615	101,8	97,29	A	14	42	35,7	28,58	82	38,1	0,77	PHS 08B-1DSTB24
25	2012	105,8	101,33	A	14	50	35,7	28,58	86	31,8	0,86	PHS 08B-1DSTB25

* Weight for rim only

For hardened teeth sprockets, add "H" after the sprocket profile e.g. PHS 08B-1AH8.

Type A Taper Bush

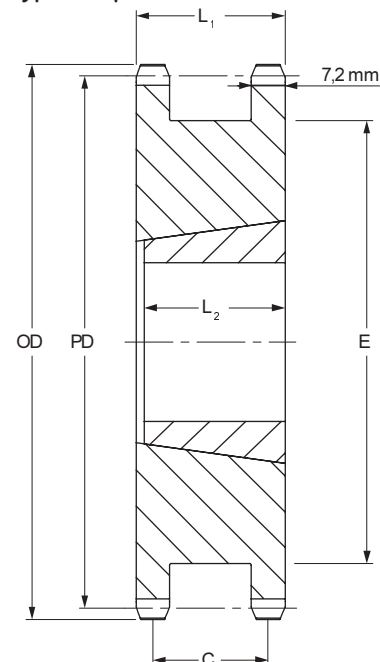



Metric sprockets

Double Simplex

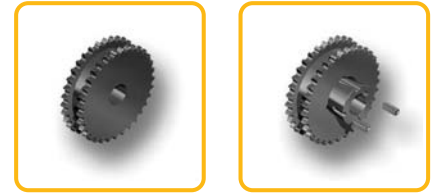

ISO 10B-1 15,88 mm Pitch

Double Simplex Type A

No. Teeth	Diameters		Type	Bore		Dimensions			Weight kg	Designation
	Outside	Pitch		Min	Max	L	C	E		
12	68,0	61,34	A	15	30	42,0	27,9	45	0,59	PHS 10B-1DSA12
13	73,0	66,32	A	15	34	42,0	27,9	48	0,70	PHS 10B-1DSA13
14	78,0	71,34	A	15	36	42,0	27,9	55	0,83	PHS 10B-1DSA14
15	83,0	76,36	A	15	40	42,0	27,9	58	0,95	PHS 10B-1DSA15
16	88,0	81,37	A	15	42	42,0	27,9	64	1,09	PHS 10B-1DSA16
17	93,0	86,39	A	15	44	42,0	27,9	68	1,32	PHS 10B-1DSA17
18	98,0	91,42	A	15	47	42,0	27,9	73	1,50	PHS 10B-1DSA18
19	103,3	96,45	A	19	52	42,0	27,9	79	1,68	PHS 10B-1DSA19
20	108,4	101,49	A	19	57	42,0	27,9	83	1,91	PHS 10B-1DSA20
21	113,4	106,52	A	19	57	42,0	27,9	89	2,18	PHS 10B-1DSA21
22	118,0	111,55	A	19	61	42,0	27,9	93	2,41	PHS 10B-1DSA22
23	123,4	116,58	A	19	65	42,0	27,9	99	2,64	PHS 10B-1DSA23
24	128,3	121,62	A	19	69	42,0	27,9	103	2,86	PHS 10B-1DSA24
25	134,0	126,66	A	19	72	42,0	27,9	109	3,16	PHS 10B-1DSA25

For hardened teeth sprockets, add "H" after the sprocket profile e.g. PHS 08B-1AH8.

Type A

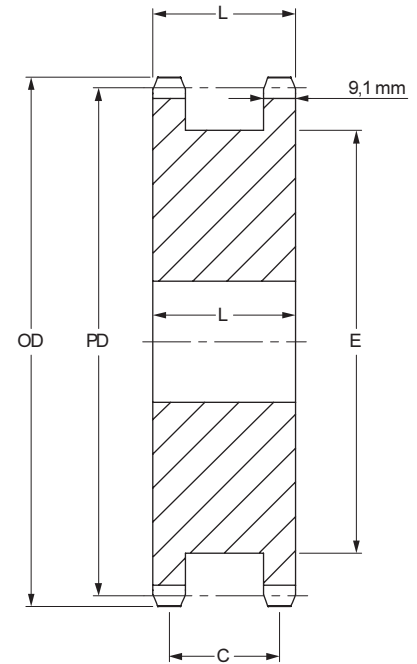

Double Simplex Taper Bushed Type A

No. Teeth	Bushing Size	Diameters		Type	Bore		Dimensions				Weight* kg	Designation
		Outside	Pitch		Min	Max	L ₁	C	E	L ₂		
12	1108	68,0	61,34	A	9	28	42,0	33,34	45	22,2	0,46	PHS 10B-1DSTB12
13	1108	73,0	66,32	A	9	28	42,0	33,34	50	22,2	0,56	PHS 10B-1DSTB13
14	1108	78,0	71,34	A	9	28	42,0	33,34	55	38,1	0,70	PHS 10B-1DSTB14
15	1215	83,0	76,36	A	11	32	42,0	33,34	60	38,1	0,68	PHS 10B-1DSTB15
16	1215	88,0	81,37	A	11	32	42,0	33,34	65	38,1	0,78	PHS 10B-1DSTB16
17	1615	93,0	86,39	A	14	42	42,0	33,34	68	38,1	0,82	PHS 10B-1DSTB17
18	1615	98,3	91,42	A	14	42	42,0	33,34	73	38,1	1,04	PHS 10B-1DSTB18
19	1615	103,3	96,42	A	14	42	42,0	33,34	78	38,1	1,23	PHS 10B-1DSTB19
20	1615	108,4	101,49	A	14	42	42,0	33,34	83	31,8	1,35	PHS 10B-1DSTB20
21	2012	113,4	106,52	A	14	50	42,0	33,34	88	31,8	1,50	PHS 10B-1DSTB21
22	2012	118,0	111,55	A	14	50	42,0	33,34	93	31,8	1,59	PHS 10B-1DSTB22
23	2012	123,4	116,58	A	14	50	42,0	33,34	98	31,8	1,68	PHS 10B-1DSTB23
24	2012	128,3	121,62	A	14	50	42,0	33,34	103	31,8	1,77	PHS 10B-1DSTB24
25	2012	134,0	126,66	A	14	50	42,0	33,34	108	31,8	1,86	PHS 10B-1DSTB25

* Weight for rim only

For hardened teeth sprockets, add "H" after the sprocket profile e.g. PHS 08B-1AH8.

Type A Taper Bush

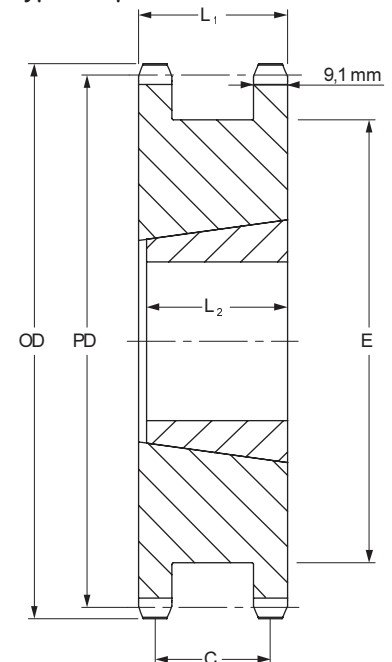

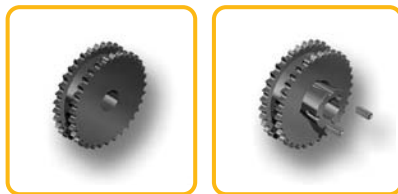

Metric sprockets

Double Simplex

- ▶ Belts
- ▶ Chains
- ▶ Couplings
- ▶ Bushings and Hubs
- ▶ Sprockets
- ▶ Pulleys
- ▶ Smart tools

ISO 12B-1 19,05 mm Pitch

Double Simplex Type A

No. Teeth	Diameters		Type	Bore		Dimensions			Weight kg	Designation
	Outside	Pitch		Min	Max	L	C	E		
12	81,5	73,61	A	20	35	45,0	33,9	53	1,08	PHS 12B-1DSA12
13	87,5	79,59	A	20	38	45,0	33,9	59	1,29	PHS 12B-1DSA13
14	93,6	85,62	A	20	42	45,0	33,9	65	1,52	PHS 12B-1DSA14
15	99,8	91,61	A	20	38	45,0	33,9	71	1,73	PHS 12B-1DSA15
16	105,5	97,63	A	20	46	45,0	33,9	77	2,09	PHS 12B-1DSA16
17	111,5	103,67	A	20	55	45,0	33,9	71	2,41	PHS 12B-1DSA17
18	118,0	109,71	A	20	58	45,0	33,9	88	2,95	PHS 12B-1DSA18
19	124,2	115,75	A	20	62	45,0	33,9	71	3,09	PHS 12B-1DSA19
20	129,7	121,78	A	24	65	45,0	33,9	100	3,30	PHS 12B-1DSA20
21	136,0	127,82	A	24	70	45,0	33,9	71	3,62	PHS 12B-1DSA21
22	141,8	133,86	A	24	73	45,0	33,9	112	4,00	PHS 12B-1DSA22
23	149,0	139,90	A	24	77	45,0	33,9	71	4,60	PHS 12B-1DSA23
24	153,9	145,94	A	24	81	45,0	33,9	124	4,95	PHS 12B-1DSA24
25	160,3	151,94	A	24	85	45,0	33,9	71	5,30	PHS 12B-1DSA25

For hardened teeth sprockets, add "H" after the sprocket profile e.g. PHS 08B-1AH8.

Type A

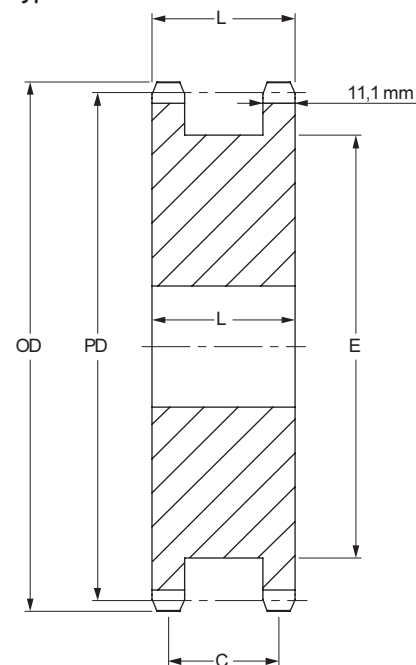

Double Simplex Taper Bushed Type A

No. Teeth	Bushing Size	Diameters		Type	Bore		Dimensions				Weight* kg	Designation
		Outside	Pitch		Min	Max	L ₁	C	E	L ₂		
12	1215	81,5	73,61	A	11	32	49,2	38,10	53	31,8	0,95	PHS 12B-1DSTB12
13	1215	87,5	79,59	A	11	32	49,2	38,10	59	31,8	1,19	PHS 12B-1DSTB13
14	1215	93,6	85,62	A	11	32	49,2	38,10	65	31,8	1,32	PHS 12B-1DSTB14
15	1615	99,8	91,61	A	14	42	49,2	38,10	72	31,8	1,44	PHS 12B-1DSTB15
16	1615	105,5	97,63	A	14	42	49,2	38,10	77	31,8	1,74	PHS 12B-1DSTB16
17	1615	111,5	103,67	A	14	42	49,2	38,10	82	31,8	2,05	PHS 12B-1DSTB17
18	2012	118,0	109,71	A	14	50	49,2	38,10	88	31,8	2,27	PHS 12B-1DSTB18
19	2012	124,2	115,75	A	14	50	49,2	38,10	94	31,8	2,64	PHS 12B-1DSTB19
20	2517	129,7	121,78	A	16	65	49,2	38,10	100	44,5	2,55	PHS 12B-1DSTB20
21	2517	136,0	127,82	A	16	65	49,2	38,10	106	44,5	2,91	PHS 12B-1DSTB21
22	2517	141,8	133,86	A	16	65	49,2	38,10	112	44,5	3,11	PHS 12B-1DSTB22
23	2517	149,0	139,90	A	16	65	49,2	38,10	118	44,5	3,32	PHS 12B-1DSTB23
24	2517	153,9	145,94	A	16	65	49,2	38,10	124	44,5	3,53	PHS 12B-1DSTB24
25	2517	160,3	151,94	A	16	65	49,2	38,10	130	44,5	3,73	PHS 12B-1DSTB25

* Weight for rim only

For hardened teeth sprockets, add "H" after the sprocket profile e.g. PHS 08B-1AH8.

Type A Taper Bush

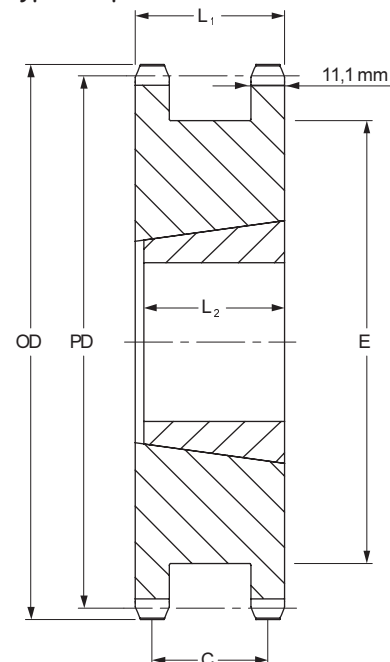



Metric sprockets

Double Simplex

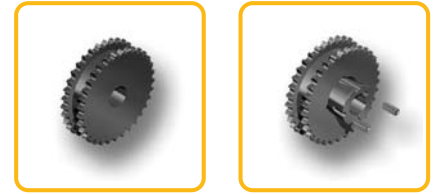

ISO 16B-1 25,40 mm Pitch

Double Simplex Type A

No. Teeth	Diameters		Type	Bore		Dimensions			Weight kg	Designation
	Outside	Pitch		Min	Max	L	C	E		
12	109,0	98,14	A	24	46	64,0	47,8	72	2,48	PHS 16B-1DSA12
13	117,0	106,12	A	24	50	64,0	47,8	78	3,09	PHS 16B-1DSA13
14	125,0	114,15	A	24	57	64,0	47,8	84	3,70	PHS 16B-1DSA14
15	133,0	122,17	A	24	60	64,0	47,8	95	4,35	PHS 16B-1DSA15
16	141,0	130,20	A	24	68	64,0	47,8	101	5,00	PHS 16B-1DSA16
17	149,0	138,22	A	24	71	64,0	47,8	111	5,75	PHS 16B-1DSA17
18	157,0	146,28	A	24	79	64,0	47,8	117	6,50	PHS 16B-1DSA18
19	165,2	154,33	A	24	82	64,0	47,8	127	7,40	PHS 16B-1DSA19
20	173,2	162,38	A	24	88	64,0	47,8	134	8,30	PHS 16B-1DSA20
21	181,2	170,43	A	24	95	64,0	47,8	143	9,20	PHS 16B-1DSA21
22	189,3	178,48	A	24	100	64,0	47,8	151	10,15	PHS 16B-1DSA22
23	197,5	186,59	A	24	107	64,0	47,8	160	11,20	PHS 16B-1DSA23
24	205,5	194,59	A	24	111	64,0	47,8	168	12,80	PHS 16B-1DSA24
25	213,5	178,49	A	24	115	64,0	47,8	176	14,40	PHS 16B-1DSA25

For hardened teeth sprockets, add "H" after the sprocket profile e.g. PHS 08B-1AH8.

Type A

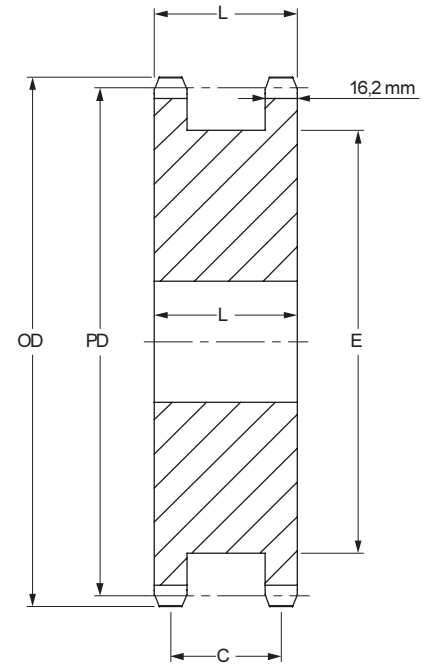

Double Simplex Taper Bushed Type A

No. Teeth	Bushing Size	Diameters		Type	Bore		Dimensions				Weight* kg	Designation
		Outside	Pitch		Min	Max	L ₁	C	E	L ₂		
12	1615	109,0	98,14	A	14	42	63,5	46,50	72	38,1	1,92	PHS 16B-1DSTB12
13	1615	117,0	106,12	A	14	42	63,5	46,50	80	38,1	2,53	PHS 16B-1DSTB13
14	2012	125,0	114,15	A	14	50	63,5	46,50	88	31,8	2,53	PHS 16B-1DSTB14
15	2012	133,0	122,17	A	14	50	63,5	46,50	96	31,8	3,10	PHS 16B-1DSTB15
16	2012	141,0	130,20	A	14	50	63,5	46,50	104	31,8	3,68	PHS 16B-1DSTB16
17	2517	149,0	138,22	A	16	65	63,5	46,50	112	44,5	3,89	PHS 16B-1DSTB17
18	2517	157,0	146,28	A	16	65	63,5	46,50	120	44,5	4,65	PHS 16B-1DSTB18
19	3020	165,2	154,33	A	25	75	63,5	46,50	128	50,8	4,50	PHS 16B-1DSTB19
20	3020	173,2	162,38	A	25	75	63,5	46,50	135	50,8	5,10	PHS 16B-1DSTB20
21	3020	181,2	170,43	A	25	75	63,5	46,50	142	50,8	6,00	PHS 16B-1DSTB21
22	3020	189,3	178,48	A	25	75	63,5	46,50	151	50,8	6,20	PHS 16B-1DSTB22
23	3525	197,5	186,59	A	35	90	63,5	46,50	160	63,5	7,15	PHS 16B-1DSTB23
24	3525	205,5	194,59	A	35	90	63,5	46,50	167	63,5	8,10	PHS 16B-1DSTB24
25	3525	213,5	178,49	A	35	90	63,5	46,50	175	63,5	9,00	PHS 16B-1DSTB25

* Weight for rim only

For hardened teeth sprockets, add "H" after the sprocket profile e.g. PHS 08B-1AH8.

Type A Taper Bush

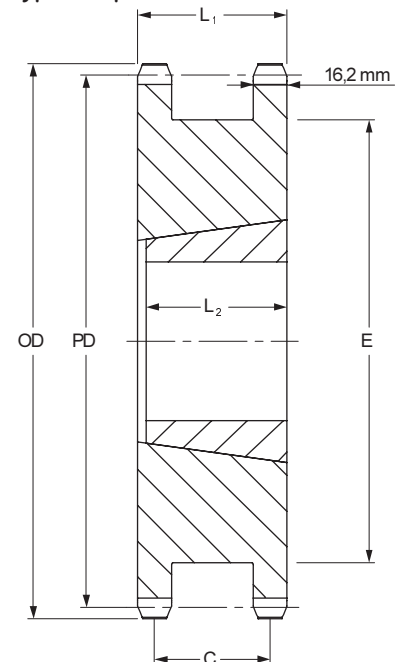

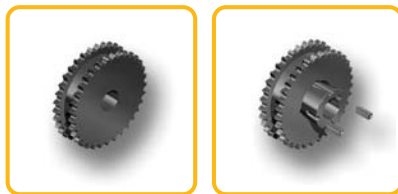

Metric sprockets

Double Simplex

- ▶ Belts
- ▶ Chains
- ▶ Couplings
- ▶ Bushings and Hubs
- ▶ Sprockets
- ▶ Pulleys
- ▶ Smart tools

ISO 20B-1 31,75 mm Pitch

Double Simplex Type A

No. Teeth	Diameters		Type	Bore		Dimensions			Weight kg	Designation
	Outside	Pitch		Min	Max	L	C	E		
13	147,8	132,66	A	25	63,5	68,3	49,8	96	5,09	PHS 20B-1DSA13
14	158,2	142,67	A	25	69,85	68,3	49,8	106	6,14	PHS 20B-1DSA14
15	168,4	152,70	A	32	77,79	68,3	49,8	116	7,64	PHS 20B-1DSA15
16	178,6	162,74	A	32	82,55	68,3	49,8	114	8,77	PHS 20B-1DSA16
17	189,0	172,80	A	32	92,08	68,3	49,8	124	9,77	PHS 20B-1DSA17
18	199,1	182,83	A	32	95,25	68,3	49,8	134	10,45	PHS 20B-1DSA18
19	209,3	192,91	A	32	106,36	68,3	49,8	157	11,36	PHS 20B-1DSA19
20	219,5	202,97	A	32	106,36	68,3	49,8	167	12,05	PHS 20B-1DSA20
21	229,6	213,03	A	32	133,35	68,3	49,8	177	13,18	PHS 20B-1DSA21

For hardened teeth sprockets, add "H" after the sprocket profile e.g. PHS 08B-1AH8.

Type A

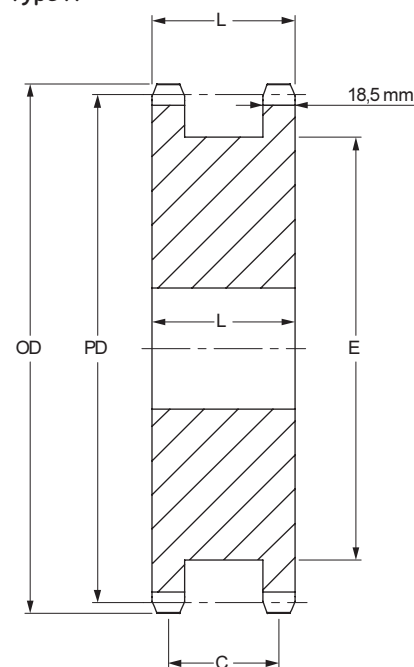

Double Simplex Taper Bushed Type A

No. Teeth	Bushing Size	Diameters		Type	Bore		Dimensions				Weight* kg	Designation
		Outside	Pitch		Min	Max	L ₁	C	E	L ₂		
15	2517	167,9	152,72	A	16	60	68,3	49,80	115	44,5	4,20	PHS 20B-1DSTB15
16	2517	177,9	162,75	A	16	60	68,3	49,80	127	44,5	5,91	PHS 20B-1DSTB16
17	3020	172,8	172,78	A	25	75	68,3	49,80	137	50,8	6,36	PHS 20B-1DSTB17
18	3020	182,8	182,85	A	25	75	68,3	49,80	147	50,8	7,27	PHS 20B-1DSTB18
19	3020	192,9	192,91	A	25	75	68,3	49,80	157	50,8	9,09	PHS 20B-1DSTB19
20	3020	218,1	202,98	A	25	75	68,3	49,80	167	50,8	10,85	PHS 20B-1DSTB20
21	3020	228,3	213,03	A	25	75	68,3	49,80	177	50,8	12,50	PHS 20B-1DSTB21

* Weight for rim only

For hardened teeth sprockets, add "H" after the sprocket profile e.g. PHS 08B-1AH8.

Type A Taper Bush

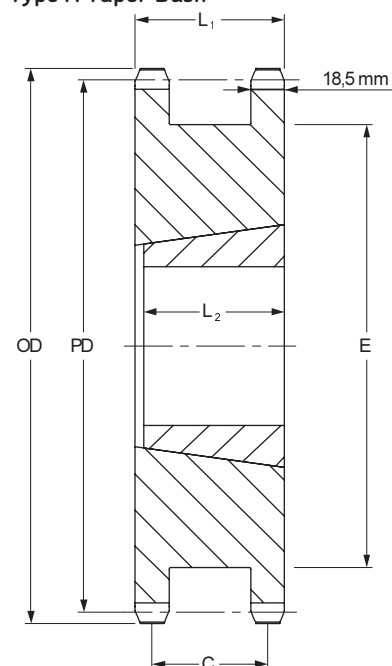



Metric sprockets



Duplex
Standard

ISO 06B-2 9,525 mm Pitch

Type B

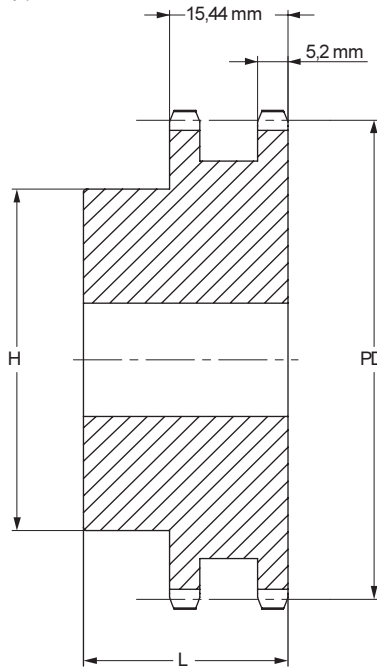

ISO 08B-2 12,70 mm Pitch

Type B

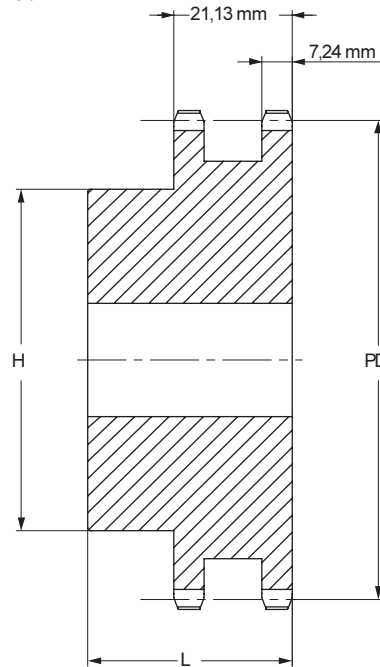

Pilot bore Type B

Pilot bore Type B

No. Teeth	Pitch Diameter mm	Type	Bore		Hub		Weight kg	Designation
			Min	Max	H	L		
			mm	mm	mm	mm		
12	36,80	B	10	12	25	25	0,11	PHS 06B-2B12
13	39,79	B	10	12	28	25	0,14	PHS 06B-2B13
14	42,80	B	10	18	31	25	0,17	PHS 06B-2B14
15	45,81	B	10	18	34	25	0,20	PHS 06B-2B15
16	48,82	B	12	20	37	30	0,26	PHS 06B-2B16
17	51,83	B	12	23	40	30	0,32	PHS 06B-2B17
18	54,85	B	12	25	43	30	0,37	PHS 06B-2B18
19	57,87	B	12	28	46	30	0,42	PHS 06B-2B19
20	60,89	B	12	25	49	30	0,48	PHS 06B-2B20
21	63,91	B	12	30	52	30	0,54	PHS 06B-2B21
22	66,93	B	12	28	55	30	0,61	PHS 06B-2B22
23	69,95	B	12	35	58	30	0,67	PHS 06B-2B23
24	72,97	B	12	32	61	30	0,74	PHS 06B-2B24
25	76,00	B	12	40	64	30	0,81	PHS 06B-2B25
26	79,02	B	12	32	67	30	0,92	PHS 06B-2B26
27	82,05	B	12	40	70	30	0,97	PHS 06B-2B27
28	85,07	B	12	32	73	30	1,08	PHS 06B-2B28
29	88,09	B	12	32	76	30	1,15	PHS 06B-2B29
30	91,12	B	12	40	79	30	1,23	PHS 06B-2B30
32	97,17	B	16	52	80	30	1,38	PHS 06B-2B32
35	106,26	B	16	52	80	30	1,61	PHS 06B-2B35
36	109,29	B	16	60	90	30	1,69	PHS 06B-2B36
38	115,35	B	16	50	90	30	1,84	PHS 06B-2B38
40	121,40	B	16	52	90	30	2,00	PHS 06B-2B40
42	127,46	B	16	60	90	40	2,15	PHS 06B-2B42
45	136,55	B	16	50	90	40	2,01	PHS 06B-2B45
48	145,64	B	16	60	90	40	2,61	PHS 06B-2B48
52	157,75	B	16	60	90	40	2,92	PHS 06B-2B52
57	172,91	B	16	50	90	40	2,34	PHS 06B-2B57
60	182,00	B	16	60	90	40	3,53	PHS 06B-2B60
68	206,24	B	16	60	90	40	4,14	PHS 06B-2B68
70	212,30	B	16	60	90	40	4,30	PHS 06B-2B70
72	218,37	B	16	60	90	40	4,45	PHS 06B-2B72
76	230,49	B	16	50	90	40	3,35	PHS 06B-2B76
84	254,74	B	16	60	90	40	5,37	PHS 06B-2B84
95	288,08	B	16	62	90	40	6,21	PHS 06B-2B95
96	291,11	B	16	62	90	40	6,29	PHS 06B-2B96
114	345,68	B	16	62	90	40	7,67	PHS 06B-2B114

No. Teeth	Pitch Diameter mm	Type	Bore		Hub		Weight kg	Designation
			Min	Max	H	L		
			mm	mm	mm	mm		
10	41,10	B	10	18	28	32	0,15	PHS 08B-2B10
11	45,07	B	12	21	32	35	0,22	PHS 08B-2B11
12	49,07	B	12	19	35	35	0,29	PHS 08B-2B12
13	53,06	B	12	21	38	35	0,36	PHS 08B-2B13
14	57,07	B	12	28	42	35	0,44	PHS 08B-2B14
15	61,09	B	12	28	46	35	0,52	PHS 08B-2B15
16	65,10	B	14	33	50	35	0,61	PHS 08B-2B16
17	69,11	B	14	30	54	35	0,70	PHS 08B-2B17
18	73,14	B	14	38	58	35	0,81	PHS 08B-2B18
19	77,16	B	14	40	62	35	0,91	PHS 08B-2B19
20	81,19	B	14	40	66	35	1,10	PHS 08B-2B20
21	85,22	B	16	40	70	40	1,29	PHS 08B-2B21
22	89,24	B	16	45	70	40	1,37	PHS 08B-2B22
23	93,27	B	16	50	70	40	1,46	PHS 08B-2B23
24	97,29	B	16	50	75	40	1,64	PHS 08B-2B24
25	101,33	B	16	50	80	40	1,83	PHS 08B-2B25
26	105,36	B	16	56	85	40	1,96	PHS 08B-2B26
27	109,40	B	16	50	85	40	2,09	PHS 08B-2B27
28	113,42	B	16	60	90	40	2,31	PHS 08B-2B28
29	117,46	B	16	62	95	40	2,53	PHS 08B-2B29
30	121,50	B	16	50	100	40	2,75	PHS 08B-2B30
32	129,56	B	20	64	100	40	3,08	PHS 08B-2B32
34	137,64	B	20	64	100	40	3,24	PHS 08B-2B34
35	141,68	B	20	64	100	40	3,41	PHS 08B-2B35
36	145,72	B	20	73	100	40	3,74	PHS 08B-2B36
38	153,80	B	20	55	100	40	4,08	PHS 08B-2B38
40	161,87	B	20	73	100	50	4,00	PHS 08B-2B40
42	169,95	B	20	73	108	50	3,90	PHS 08B-2B42
45	182,07	B	20	55	108	50	3,70	PHS 08B-2B45
48	194,18	B	20	73	108	50	4,10	PHS 08B-2B48
54	218,43	B	20	73	108	50	4,70	PHS 08B-2B54
57	230,54	B	20	55	108	50	5,01	PHS 08B-2B57
60	242,66	B	20	73	108	50	5,34	PHS 08B-2B60
68	274,99	B	20	73	108	55	5,68	PHS 08B-2B68
72	291,16	B	20	73	108	55	6,02	PHS 08B-2B72
76	307,33	B	20	60	108	55	6,36	PHS 08B-2B76
84	339,65	B	20	80	120	55	8,31	PHS 08B-2B84
95	384,10	B	20	60	110	55	10,26	PHS 08B-2B95
96	388,15	B	20	80	110	55	11,00	PHS 08B-2B96
114	460,90	B	20	80	110	55	12,45	PHS 08B-2B114

Maximum bores can accommodate standard keyways. Larger bores are available where a shallow keyway is used or no keyway is required.

For hardened teeth sprockets, add "H" after the sprocket profile e.g. PHS 08B-1AH8.

Maximum bores can accommodate standard keyways. Larger bores are available where a shallow keyway is used or no keyway is required.

For hardened teeth sprockets, add "H" after the sprocket profile e.g. PHS 08B-1AH8.



Metric sprockets

Duplex

Standard

- ▶ Belts
- ▶ Chains
- ▶ Couplings
- ▶ Bushings and Hubs
- ▶ Sprockets
- ▶ Pulleys
- ▶ Smart tools

ISO 10B-2 15,88 mm Pitch

Pilot bore Type B

No. Teeth	Pitch Diameter	Type	Bore		Hub		Weight	Designation
			Min	Max	H	L		
	mm		mm	mm	mm	mm	kg	
11	56,34	B	14	24	39	40	0,45	PHS 10B-2B11
12	61,34	B	14	25	44	40	0,57	PHS 10B-2B12
13	66,32	B	14	29	49	40	0,70	PHS 10B-2B13
14	71,34	B	14	35	54	40	0,84	PHS 10B-2B14
15	76,36	B	14	35	59	40	0,99	PHS 10B-2B15
16	81,37	B	16	40	64	45	1,23	PHS 10B-2B16
17	86,39	B	16	40	69	45	1,47	PHS 10B-2B17
18	91,42	B	16	48	74	45	1,68	PHS 10B-2B18
19	96,45	B	16	46	79	45	1,90	PHS 10B-2B19
20	101,49	B	16	56	84	45	2,10	PHS 10B-2B20
21	106,52	B	16	55	85	45	2,31	PHS 10B-2B21
22	111,55	B	16	60	90	45	2,58	PHS 10B-2B22
23	116,58	B	16	55	95	45	2,85	PHS 10B-2B23
24	121,62	B	16	64	100	45	3,14	PHS 10B-2B24
25	126,66	B	16	55	105	45	3,44	PHS 10B-2B25
26	131,70	B	20	73	110	45	3,69	PHS 10B-2B26
27	136,75	B	20	55	110	45	3,95	PHS 10B-2B27
28	141,78	B	20	76	115	45	4,25	PHS 10B-2B28
29	146,83	B	20	76	115	45	4,55	PHS 10B-2B29
30	151,87	B	20	58	120	45	4,87	PHS 10B-2B30
32	161,95	B	20	80	120	45	4,95	PHS 10B-2B32
35	177,10	B	20	80	120	45	5,08	PHS 10B-2B35
36	182,15	B	20	80	120	45	5,11	PHS 10B-2B36
38	192,24	B	20	58	120	45	5,20	PHS 10B-2B38
40	202,34	B	20	80	120	45	5,41	PHS 10B-2B40
45	227,58	B	20	60	120	50	5,94	PHS 10B-2B45
48	242,73	B	20	80	120	50	7,27	PHS 10B-2B48
57	288,18	B	20	60	120	50	8,61	PHS 10B-2B57
60	303,32	B	20	85	120	57	9,30	PHS 10B-2B60
70	353,84	B	20	85	120	57	9,99	PHS 10B-2B70
76	384,16	B	20	85	120	57	10,68	PHS 10B-2B76
80	404,35	B	20	85	130	58	11,00	PHS 10B-2B80
95	480,14	B	20	85	130	58	12,00	PHS 10B-2B95
114	576,13	B	20	85	130	58	13,00	PHS 10B-2B114

Maximum bores can accommodate standard keyways. Larger bores are available where a shallow keyway is used or no keyway is required.

For hardened teeth sprockets, add "H" after the sprocket profile e.g. PHS 08B-1AH8.

Type B

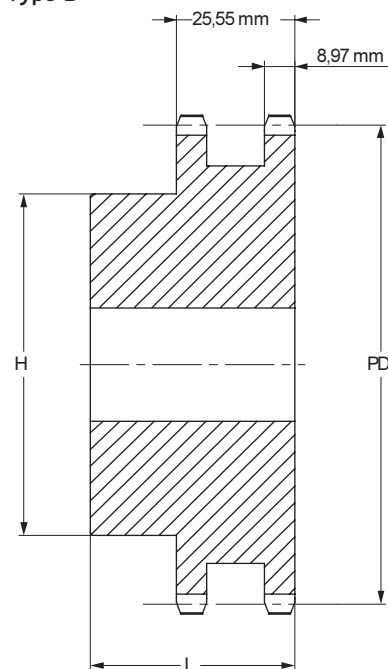



Metric sprockets



Duplex
Standard

ISO 12B-2 19,05 mm Pitch

Pilot bore Type B/C

No. Teeth	Pitch Diameter mm	Type	Bore		Hub		Weight kg	Designation
			Min mm	Max mm	H mm	L mm		
10	61,65	B	12	32	42	45	0,57	PHS 12B-2B10
11	67,61	B	16	32	47	50	0,80	PHS 12B-2B11
12	73,61	B	16	32	53	50	1,03	PHS 12B-2B12
13	79,59	B	16	36	59	50	1,26	PHS 12B-2B13
14	85,61	B	16	42	65	50	1,52	PHS 12B-2B14
15	91,63	B	16	44	71	50	1,78	PHS 12B-2B15
16	97,65	B	20	51	77	50	2,08	PHS 12B-2B16
17	103,67	B	20	55	83	50	2,37	PHS 12B-2B17
18	109,71	B	20	60	89	50	2,72	PHS 12B-2B18
19	115,75	B	20	55	95	50	3,07	PHS 12B-2B19
20	121,78	B	20	64	100	50	3,39	PHS 12B-2B20
21	127,82	B	20	60	100	50	3,70	PHS 12B-2B21
22	133,86	B	20	64	100	50	4,11	PHS 12B-2B22
23	139,90	B	20	60	110	50	4,52	PHS 12B-2B23
24	145,94	B	20	73	110	50	4,96	PHS 12B-2B24
25	152,00	B	20	60	120	50	5,39	PHS 12B-2B25
26	158,04	B	20	80	120	50	5,74	PHS 12B-2B26
27	164,09	B	20	60	120	50	6,09	PHS 12B-2B27
28	170,13	B	20	80	120	50	6,45	PHS 12B-2B28
30	182,25	B	20	60	120	50	7,17	PHS 12B-2B30
32	194,36	B	20	85	120	50	8,41	PHS 12B-2B32
35	212,52	B	20	85	120	50	9,70	PHS 12B-2B35
36	218,58	B	25	85	120	50	10,12	PHS 12B-2B36
38	230,69	B	25	65	120	50	10,98	PHS 12B-2B38
40	242,81	B	25	85	120	50	11,84	PHS 12B-2B40
45	273,10	B	25	65	136	62	10,58	PHS 12B-2B45
48	291,27	B	25	85	136	62	15,26	PHS 12B-2B48
57	345,81	B	25	70	136	62	11,72	PHS 12B-2B57
60	363,99	B	25	85	136	62	20,40	PHS 12B-2B60
68	412,49	C	25	85	140	63	23,83	PHS 12B-2C68
76	460,99	C	25	80	140	63	18,50	PHS 12B-2C76
80	485,22	C	25	85	140	63	28,97	PHS 12B-2C80
95	576,17	C	25	93	140	63	35,39	PHS 12B-2C95
96	582,23	C	25	93	140	63	35,82	PHS 12B-2C96
114	691,36	C	25	93	140	63	43,53	PHS 12B-2C114

Maximum bores can accommodate standard keyways. Larger bores are available where a shallow keyway is used or no keyway is required.

For hardened teeth sprockets, add "H" after the sprocket profile e.g. PHS 08B-1AH8.

Type B

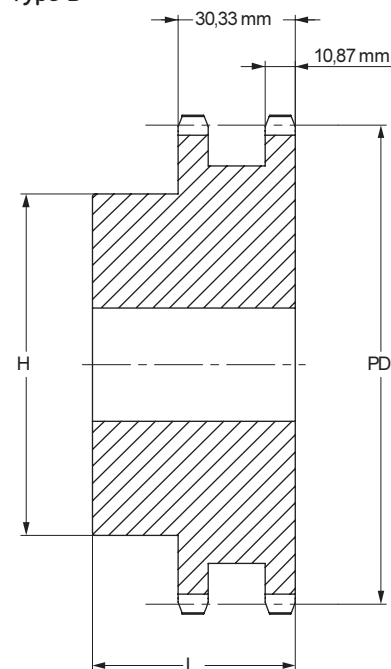

Type C

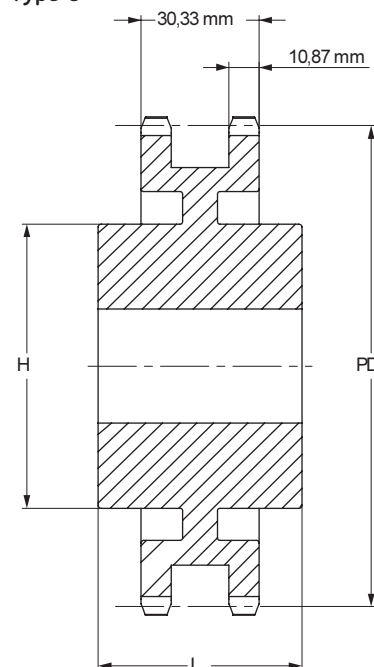



Metric sprockets

Duplex

Standard

- ▶ Belts
- ▶ Chains
- ▶ Couplings
- ▶ Bushings and Hubs
- ▶ Sprockets
- ▶ Pulleys
- ▶ Smart tools

ISO 16B-2 25,40 mm Pitch

Pilot bore Type B/C

No. Teeth	Pitch Diameter mm	Type	Bore		Hub		Weight kg	Designation
			Min mm	Max mm	H mm	L mm		
11	90,14	B	20	42	64	70	1,86	PHS 16B-2B11
12	98,14	B	20	45	72	70	2,54	PHS 16B-2B12
13	106,12	B	20	48	80	70	3,22	PHS 16B-2B13
14	114,15	B	20	53	88	70	3,90	PHS 16B-2B14
15	122,17	B	20	58	96	70	4,58	PHS 16B-2B15
16	130,20	B	20	66	104	70	5,35	PHS 16B-2B16
17	138,22	B	20	70	112	70	6,12	PHS 16B-2B17
18	146,28	B	20	80	120	70	7,02	PHS 16B-2B18
19	154,33	B	20	70	128	70	7,91	PHS 16B-2B19
20	162,38	B	20	85	130	70	8,59	PHS 16B-2B20
21	170,43	B	25	75	130	70	9,26	PHS 16B-2B21
22	178,48	B	25	85	130	70	10,05	PHS 16B-2B22
23	186,53	B	25	75	130	70	10,84	PHS 16B-2B23
24	194,59	B	25	85	130	70	11,70	PHS 16B-2B24
25	202,66	B	25	75	130	70	12,56	PHS 16B-2B25
26	210,72	B	25	85	130	70	13,52	PHS 16B-2B26
27	218,79	B	25	75	130	70	14,48	PHS 16B-2B27
28	226,85	B	25	85	130	70	15,49	PHS 16B-2B28
29	234,92	B	25	85	130	70	16,51	PHS 16B-2B29
30	243,00	B	25	75	130	70	17,52	PHS 16B-2B30
32	259,13	B	25	95	140	70	20,13	PHS 16B-2B32
35	283,36	B	25	95	140	70	24,04	PHS 16B-2B35
36	291,44	B	25	95	140	70	25,34	PHS 16B-2B36
38	307,59	B	25	75	140	70	27,95	PHS 16B-2B38
42	339,90	B	25	95	140	70	32,35	PHS 16B-2B42
45	364,13	C	25	85	140	70	22,00	PHS 16B-2C45
57	461,07	C	25	85	150	85	34,50	PHS 16B-2C57
60	485,32	C	25	95	150	85	52,14	PHS 16B-2C60
68	549,98	C	25	96	160	90	60,93	PHS 16B-2C68
76	614,65	C	25	100	160	90	51,50	PHS 16B-2C76
80	646,96	C	25	102	160	90	74,13	PHS 16B-2C80
95	768,22	C	25	100	160	90	90,62	PHS 16B-2C95
114	921,81	C	25	102	160	90	111,51	PHS 16B-2C114

Maximum bores can accommodate standard keyways. Larger bores are available where a shallow keyway is used or no keyway is required.

For hardened teeth sprockets, add "H" after the sprocket profile e.g. PHS 08B-1AH8.

Type B

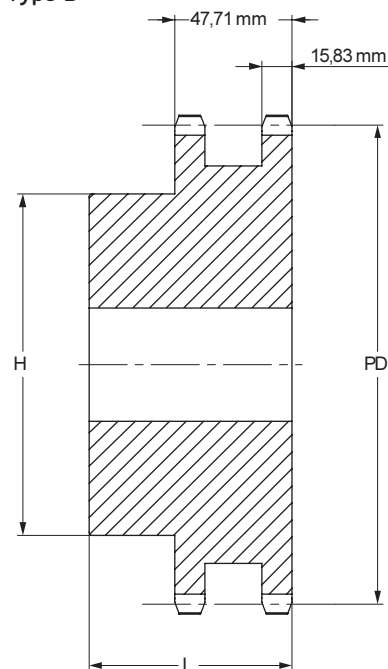

Type C

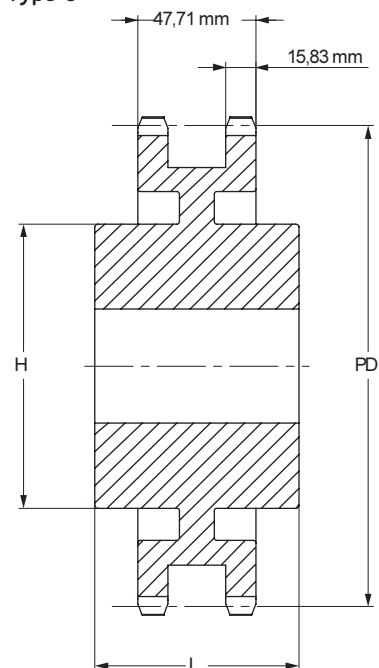



Metric sprockets



Duplex
Standard

ISO 20B-2 31,75 mm Pitch

Pilot bore Type B/C

No. Teeth	Pitch Diameter mm	Type	Bore		Hub		Weight kg	Designation
			Min	Max	H	L		
			mm	mm	mm	mm		
10	102,75	B	20	45	70	75	2,90	PHS 20B-2B10
11	112,70	B	20	52	80	80	3,67	PHS 20B-2B11
12	122,67	B	20	60	90	80	4,31	PHS 20B-2B12
13	132,67	B	20	64	100	80	5,53	PHS 20B-2B13
14	142,68	B	20	73	110	80	6,62	PHS 20B-2B14
15	152,71	B	20	80	120	80	7,76	PHS 20B-2B15
16	162,75	B	25	80	120	80	9,12	PHS 20B-2B16
17	172,79	B	25	80	120	80	10,44	PHS 20B-2B17
18	182,84	B	25	80	120	80	11,71	PHS 20B-2B18
19	192,90	B	25	80	120	80	12,92	PHS 20B-2B19
20	202,96	B	25	80	120	80	15,43	PHS 20B-2B20
21	213,03	B	25	92	140	80	16,55	PHS 20B-2B21
22	223,10	B	25	92	140	80	17,70	PHS 20B-2B22
23	233,17	B	25	92	140	80	19,05	PHS 20B-2B23
24	243,25	B	25	96	140	80	20,43	PHS 20B-2B24
25	253,32	B	25	96	140	80	21,77	PHS 20B-2B25
26	263,41	B	25	96	150	80	23,15	PHS 20B-2B26
27	273,49	B	25	96	150	80	24,97	PHS 20B-2B27
28	283,57	B	25	96	150	80	26,78	PHS 20B-2B28
30	303,75	B	25	96	150	80	30,41	PHS 20B-2B30
32	323,92	B	25	96	150	80	32,22	PHS 20B-2B32
35	354,20	C	25	100	150	80	34,02	PHS 20B-2C35
36	364,29	C	30	100	150	80	34,70	PHS 20B-2C36
38	384,48	C	30	100	150	80	43,72	PHS 20B-2C38
42	424,86	C	30	100	160	90	43,55	PHS 20B-2C42
45	455,15	C	30	100	160	90	46,72	PHS 20B-2C45
57	576,35	C	30	100	160	100	64,10	PHS 20B-2C57
60	606,66	C	30	125	160	100	79,38	PHS 20B-2C60
68	687,48	C	30	125	180	100	87,74	PHS 20B-2C68
76	768,30	C	30	125	180	100	96,11	PHS 20B-2C76
80	808,71	C	30	125	180	100	100,30	PHS 20B-2C80
95	960,28	C	30	125	180	100	115,98	PHS 20B-2C95
114	1152,26	C	30	125	180	100	135,85	PHS 20B-2C114

Maximum bores can accommodate standard keyways. Larger bores are available where a shallow keyway is used or no keyway is required.

For hardened teeth sprockets, add "H" after the sprocket profile e.g. PHS 08B-1AH8.

Type B

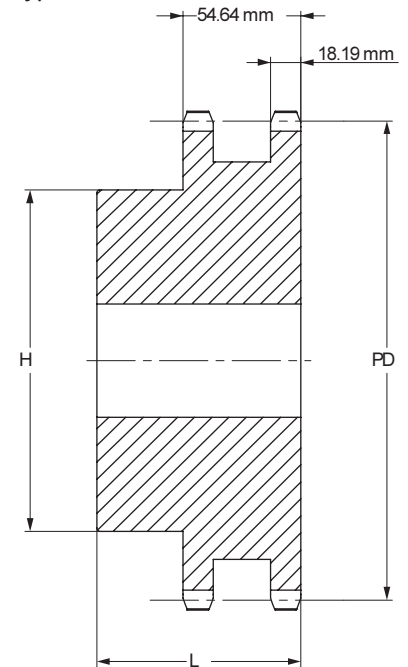

Type C

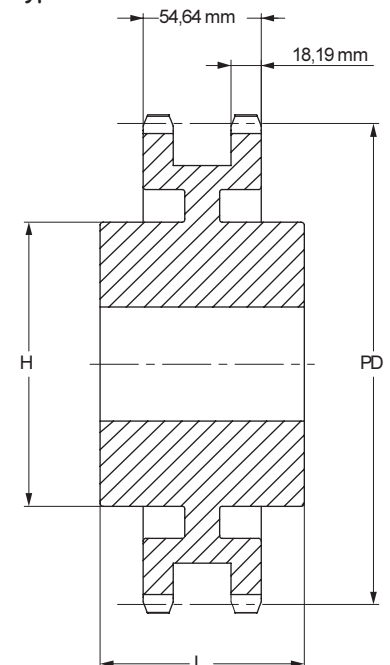



Metric sprockets

Duplex

Standard

- ▶ Belts
- ▶ Chains
- ▶ Couplings
- ▶ Bushings and Hubs
- ▶ Sprockets
- ▶ Pulleys
- ▶ Smart tools

ISO 24B-2 38,10 mm Pitch

Pilot bore Type B/C

No. Teeth	Pitch Diameter mm	Type	Bore		Hub		Weight kg	Designation
			Min mm	Max mm	H mm	L mm		
11	135,23	B	25	60	90	100	6,50	PHS 24B-2B11
12	147,21	B	25	67	102	100	8,13	PHS 24B-2B12
13	159,20	B	25	76	114	100	9,92	PHS 24B-2B13
14	171,22	B	25	84	128	100	11,98	PHS 24B-2B14
15	183,25	B	25	93	132	100	14,13	PHS 24B-2B15
16	195,29	B	25	100	136	100	16,35	PHS 24B-2B16
17	207,35	B	25	100	136	100	17,85	PHS 24B-2B17
18	219,41	B	25	108	150	100	20,35	PHS 24B-2B18
19	231,48	B	25	108	160	100	22,56	PHS 24B-2B19
20	243,55	B	25	108	160	100	24,78	PHS 24B-2B20
21	255,63	B	25	108	160	100	26,99	PHS 24B-2B21
22	267,72	B	25	108	160	100	29,74	PHS 24B-2B22
23	279,80	B	25	108	160	100	32,87	PHS 24B-2B23
24	291,90	B	25	108	160	100	36,00	PHS 24B-2B24
25	303,99	B	25	108	160	100	39,13	PHS 24B-2B25
26	316,09	B	30	108	160	100	42,26	PHS 24B-2B26
27	328,19	B	30	108	160	100	45,40	PHS 24B-2B27
28	340,29	B	30	108	160	100	48,53	PHS 24B-2B28
29	352,39	B	30	108	160	100	51,66	PHS 24B-2B29
30	364,49	B	30	108	160	100	54,79	PHS 24B-2B30
32	388,71	B	30	108	160	100	61,05	PHS 24B-2B32
38	461,37	B	30	137	160	100	72,01	PHS 24B-2B38
40	485,60	C	30	137	160	100	75,80	PHS 24B-2C40
42	509,83	C	30	137	180	100	79,59	PHS 24B-2C42
45	546,19	C	30	137	180	100	85,28	PHS 24B-2C45
48	582,54	C	30	137	180	100	90,97	PHS 24B-2C48
50	606,78	C	30	137	180	100	94,76	PHS 24B-2C50
54	655,26	C	30	161	180	110	127,46	PHS 24B-2C54
57	691,62	C	30	161	180	110	140,74	PHS 24B-2C57
60	727,99	C	30	161	180	120	154,02	PHS 24B-2C60
68	824,97	C	30	161	200	120	189,45	PHS 24B-2C68
72	873,46	C	30	161	200	120	207,16	PHS 24B-2C72
76	921,96	C	30	161	200	120	224,87	PHS 24B-2C76
95	1152,33	C	30	161	200	120	309,00	PHS 24B-2C95
96	1164,46	C	30	161	200	120	313,43	PHS 24B-2C96
114	1382,72	C	30	161	200	120	393,13	PHS 24B-2C114

Maximum bores can accommodate standard keyways. Larger bores are available where a shallow keyway is used or no keyway is required.

For hardened teeth sprockets, add "H" after the sprocket profile e.g. PHS 08B-1AH8.

Type B

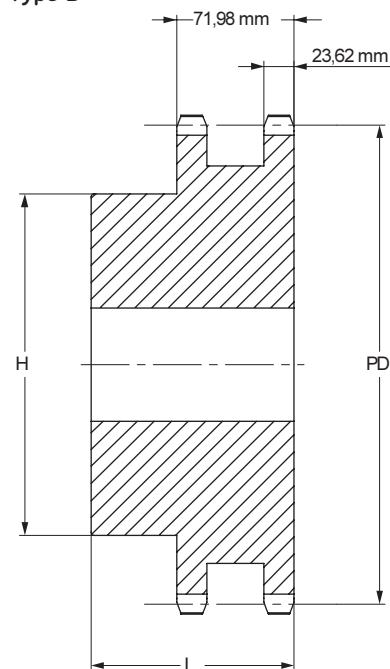

Type C

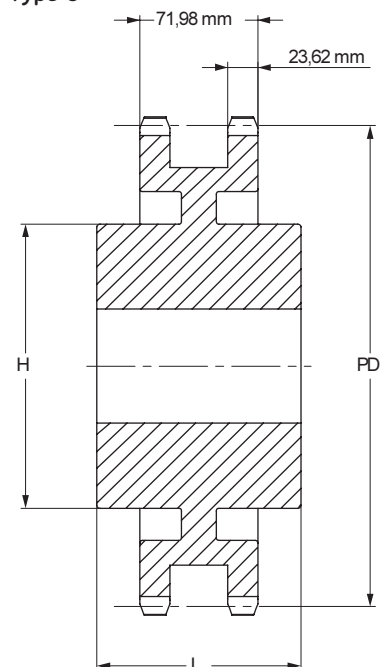



Metric sprockets



Duplex
Standard

ISO 28B-2 44,45 mm Pitch

Pilot bore Type B/C

No. Teeth	Pitch Diameter	Type	Bore		Hub		Weight	Designation
			Min	Max	H	L		
			mm	mm	mm	mm		
11	157,77	B	25	73	112	120	10,21	PHS 28B-2B11
12	171,74	B	25	84	125	120	13,02	PHS 28B-2B12
13	185,75	B	25	84	125	120	16,00	PHS 28B-2B13
14	199,76	B	25	87	125	120	19,28	PHS 28B-2B14
15	213,79	B	25	96	145	120	22,91	PHS 28B-2B15
16	227,84	B	30	108	160	120	26,92	PHS 28B-2B16
17	241,91	B	30	114	160	120	30,83	PHS 28B-2B17
18	255,98	B	30	114	160	120	34,74	PHS 28B-2B18
19	270,06	B	30	133	180	120	38,93	PHS 28B-2B19
20	284,15	B	30	133	180	120	44,27	PHS 28B-2B20
21	298,24	B	30	133	180	120	45,08	PHS 28B-2B21
22	312,34	B	30	133	180	120	48,15	PHS 28B-2B22
23	326,44	B	30	133	180	120	51,59	PHS 28B-2B23
24	340,55	B	30	133	180	120	55,03	PHS 28B-2B24
25	354,66	B	30	133	180	120	58,47	PHS 28B-2B25
26	368,77	B	30	133	180	120	64,06	PHS 28B-2B26
28	397,00	B	30	133	180	120	76,05	PHS 28B-2B28
30	425,24	B	30	133	180	120	89,16	PHS 28B-2B30
32	453,49	B	30	133	180	120	103,38	PHS 28B-2B32
38	538,27	B	30	133	200	120	97,53	PHS 28B-2B38
40	566,54	C	30	137	200	120	109,47	PHS 28B-2C40
45	637,22	C	30	137	200	120	137,32	PHS 28B-2C45
48	679,63	C	30	137	200	120	153,61	PHS 28B-2C48
54	764,46	C	30	162	200	120	204,44	PHS 28B-2C54
57	806,90	C	30	162	200	120	210,02	PHS 28B-2C57
60	849,32	C	30	162	200	130	230,82	PHS 28B-2C60
68	962,46	C	30	162	200	130	273,98	PHS 28B-2C68
72	1019,05	C	30	162	200	130	305,70	PHS 28B-2C72
76	1075,62	C	30	162	200	130	323,56	PHS 28B-2C76

Maximum bores can accommodate standard keyways. Larger bores are available where a shallow keyway is used or no keyway is required.

For hardened teeth sprockets, add "H" after the sprocket profile e.g. PHS 08B-1AH8.

Type B

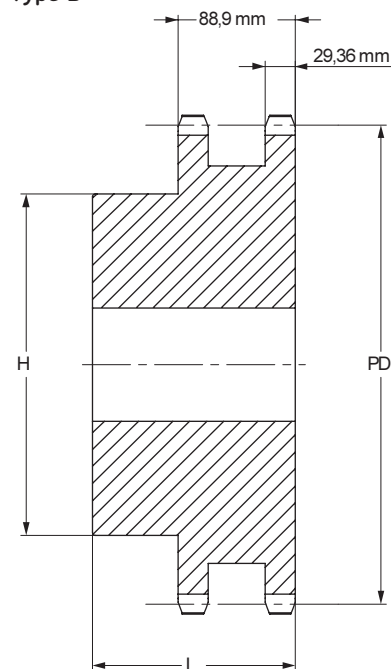

Type C

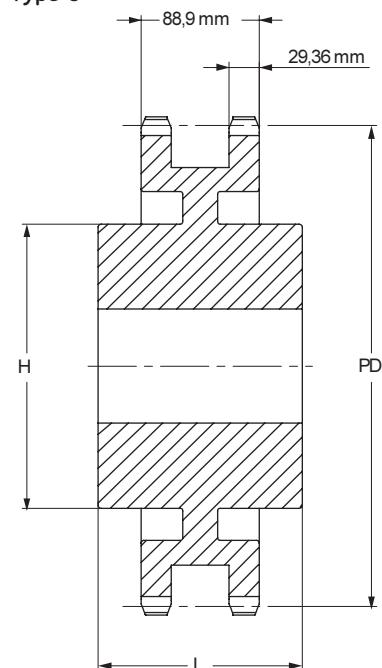



Metric sprockets

Duplex

Standard

- ▶ Belts
- ▶ Chains
- ▶ Couplings
- ▶ Bushings and Hubs
- ▶ Sprockets
- ▶ Pulleys
- ▶ Smart tools

ISO 32B-2 50,80 mm Pitch

Pilot bore Type B/C

No. Teeth	Pitch Diameter	Type	Bore		Hub		Weight	Designation
			Min	Max	H	L		
	mm	mm	mm	mm	mm	mm	kg	
11	180,34	B	30	80	120	120	10,42	PHS 32B-2B11
12	196,29	B	30	89	133	120	16,32	PHS 32B-2B12
13	212,29	B	30	96	145	120	21,77	PHS 32B-2B13
14	228,29	B	30	103	145	120	26,31	PHS 32B-2B14
15	244,30	B	30	106	160	120	30,84	PHS 32B-2B15
16	260,40	B	30	120	160	120	34,02	PHS 32B-2B16
17	276,40	B	30	120	180	120	41,28	PHS 32B-2B17
18	292,55	B	30	120	180	120	43,55	PHS 32B-2B18
19	308,66	B	30	120	200	120	48,53	PHS 32B-2B19
20	324,71	B	30	130	200	120	53,98	PHS 32B-2B20
21	340,82	B	30	130	200	120	58,97	PHS 32B-2B21
22	356,98	B	30	130	200	120	63,96	PHS 32B-2B22
23	373,08	B	30	130	200	120	71,21	PHS 32B-2B23
24	389,18	B	30	130	200	120	77,57	PHS 32B-2B24
25	405,33	B	30	130	200	120	84,82	PHS 32B-2B25
26	421,44	B	30	130	200	120	91,17	PHS 32B-2B26
28	453,69	B	30	130	200	120	101,13	PHS 32B-2B28
30	486,00	B	30	130	200	120	116,57	PHS 32B-2B30
38	615,14	B	30	178	200	120	170,25	PHS 32B-2B38
40	647,49	C	30	178	200	120	177,46	PHS 32B-2C40
45	728,26	C	30	178	200	120	195,50	PHS 32B-2C45
48	776,72	C	30	178	200	120	204,51	PHS 32B-2C48
54	873,68	C	30	178	220	120	222,53	PHS 32B-2C54
57	922,16	C	30	178	220	120	231,54	PHS 32B-2C57
68	1099,96	C	30	178	220	130	255,83	PHS 32B-2C68
76	1229,28	C	30	178	220	130	292,83	PHS 32B-2C76

Maximum bores can accommodate standard keyways. Larger bores are available where a shallow keyway is used or no keyway is required.

For hardened teeth sprockets, add "H" after the sprocket profile e.g. PHS 08B-1AH8.

Type B

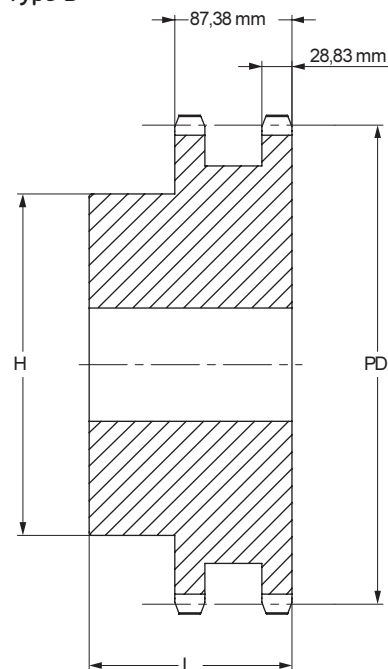

Type C

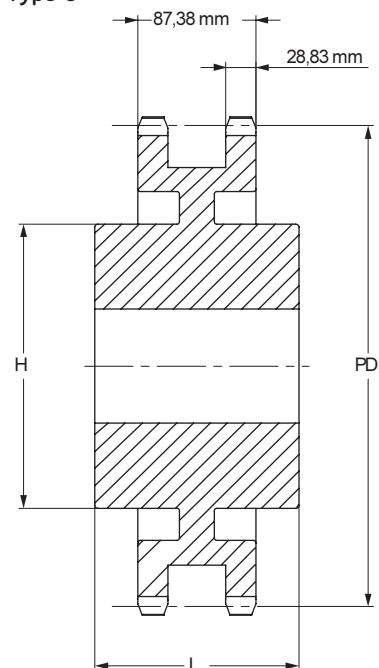

Metric sprockets

Duplex
Taper Bushed



ISO 06B-2 9,525 mm Pitch

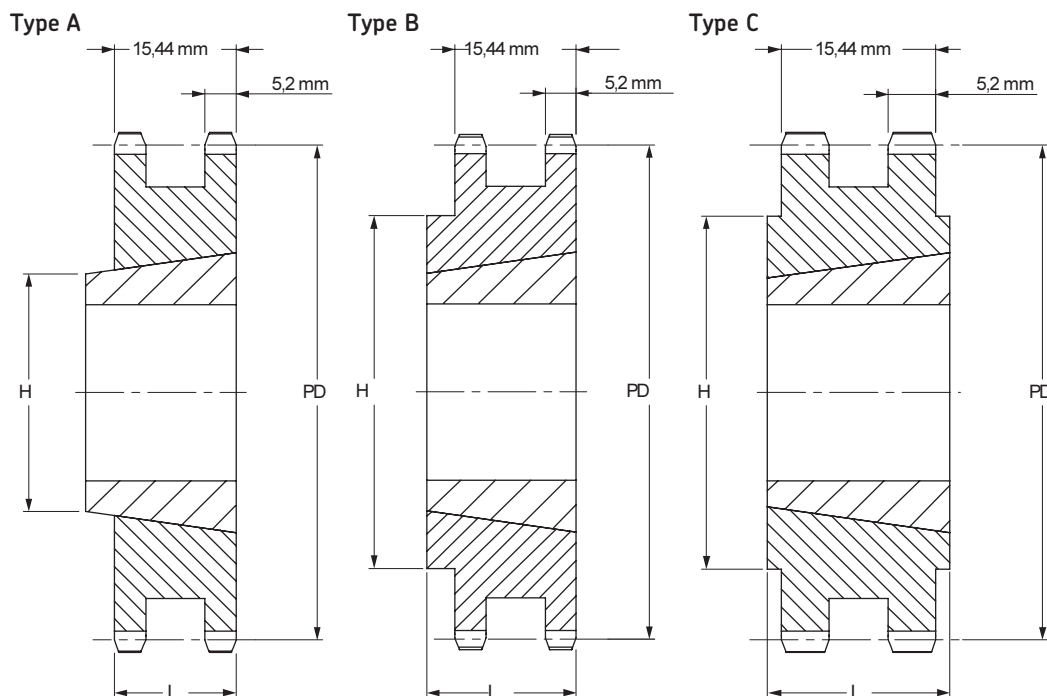

Taper Bushed Type A/B/C

No. Teeth	Pitch Diameter	Type	Bushing Size	Bore		Dimensions		Weight		Designation
				Min	Max	L	H	Rim	Bushing	
	mm			mm	mm	mm	mm	kg	kg	
16	48,82	B	1108	9	25,4	22,0	41	0,06	0,12	PHS 06B-2TB16
17	51,83	B	1008	9	25,4	22,0	41	0,12	0,09	PHS 06B-2TB17
18	54,85	B	1008	9	25,4	22,0	45	0,18	0,09	PHS 06B-2TB18
19	57,87	B	1008	9	25,4	22,0	46	0,20	0,09	PHS 06B-2TB19
20	60,89	B	1008	9	25,4	22,0	48	0,24	0,09	PHS 06B-2TB20
21	63,91	B	1008	9	25,4	22,0	49	0,29	0,09	PHS 06B-2TB21
22	66,93	B	1108	9	25,4	22,0	52	0,30	0,12	PHS 06B-2TB22
23	69,95	B	1210	11	31,8	25,0	59	0,26	0,21	PHS 06B-2TB23
24	72,97	B	1210	11	31,8	25,0	63	0,34	0,21	PHS 06B-2TB24
25	76,00	B	1210	11	31,8	25,0	64	0,41	0,21	PHS 06B-2TB25
26	79,02	B	1210	11	31,8	25,0	65	0,45	0,21	PHS 06B-2TB26
27	82,05	B	1210	11	31,8	25,0	70	0,50	0,21	PHS 06B-2TB27
28	85,07	B	1210	11	31,8	25,0	70	0,54	0,21	PHS 06B-2TB28
29	88,09	B	1210	11	31,8	25,0	70	0,51	0,21	PHS 06B-2TB29
30	91,12	B	1210	11	31,8	25,0	75	0,61	0,21	PHS 06B-2TB30
32	97,17	B	1610	14	41,3	25,0	80	0,75	0,31	PHS 06B-2TB32
35	106,26	B	1610	14	41,3	25,0	80	0,95	0,31	PHS 06B-2TB35
38	115,35	B	1610	14	41,3	25,0	80	1,16	0,31	PHS 06B-2TB38
40	121,40	B	1610	14	41,3	25,0	80	1,30	0,31	PHS 06B-2TB40
45	136,55	B	1610	14	41,3	25,0	80	1,64	0,31	PHS 06B-2TB45
48	145,64	B	1610	14	41,3	25,0	80	1,85	0,31	PHS 06B-2TB48
54	163,82	B	1610	14	41,3	25,0	80	2,26	0,31	PHS 06B-2TB54
57	172,91	B	1610	14	41,3	25,0	80	1,75	0,31	PHS 06B-2TB57
60	182,00	B	1610	14	41,3	25,0	80	2,67	0,31	PHS 06B-2TB60
70	212,30	B	1610	14	41,3	25,0	80	3,36	0,31	PHS 06B-2TB70
76	230,49	B	1610	14	41,3	25,0	80	3,19	0,31	PHS 06B-2TB76
95	288,08	B	1610	14	41,3	25,0	90	5,08	0,31	PHS 06B-2TB95
114	345,68	B	1615	14	50,8	38,0	95	6,39	0,59	PHS 06B-2TB114

For hardened teeth sprockets, add "H" after the sprocket profile e.g. PHS 08B-1AH8.



Metric sprockets

Duplex

Taper Bushed

- ▶ Belts
- ▶ Chains
- ▶ Couplings
- ▶ Bushings and Hubs
- ▶ Sprockets
- ▶ Pulleys
- ▶ Smart tools

ISO 08B-2 12,70 mm Pitch

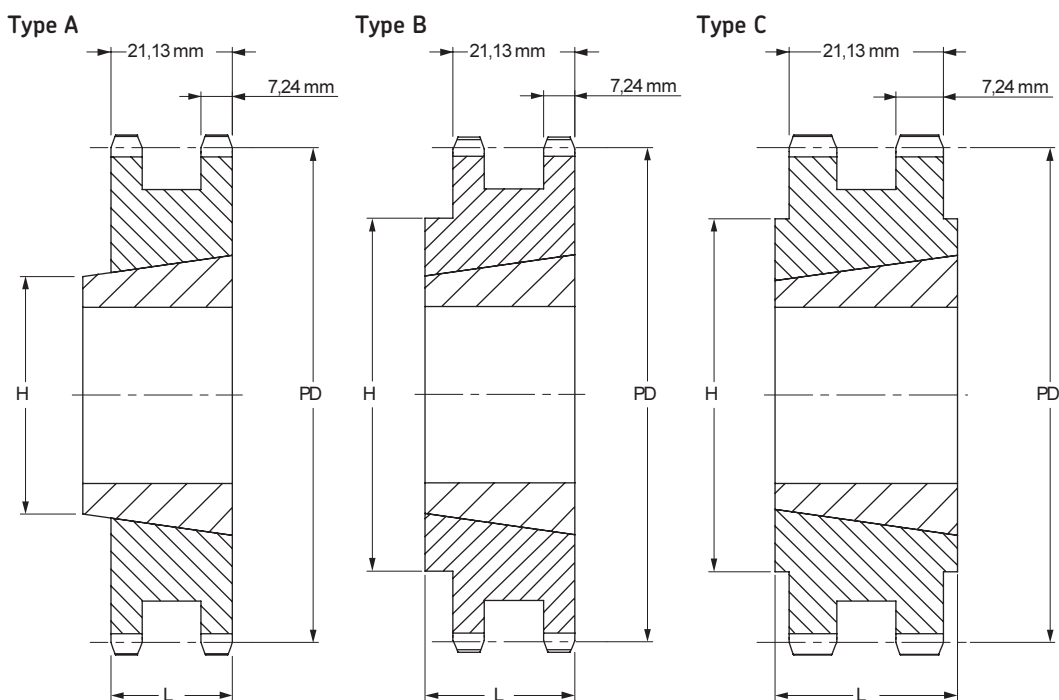

Taper Bushed Type A/B/C

No. Teeth	Pitch Diameter mm	Type	Bushing Size	Bore		Dimensions		Weight		Designation
				Min mm	Max mm	L mm	H mm	Rim kg	Bushing kg	
15	61,09	A	1008	9	25,4	22,0	46	0,23	0,09	PHS 08B-2TB15
16	65,10	A	1108	9	28,0	22,0	50	0,25	0,12	PHS 08B-2TB16
17	69,11	A	1210	11	31,8	25,0	56	0,26	0,21	PHS 08B-2TB17
18	73,14	B	1210	11	31,8	25,0	60	0,31	0,21	PHS 08B-2TB18
19	77,16	B	1210	11	31,8	25,0	62	0,43	0,21	PHS 08B-2TB19
20	81,19	B	1610	14	41,3	25,0	68	0,45	0,31	PHS 08B-2TB20
21	85,22	B	1610	14	41,3	25,0	70	0,48	0,31	PHS 08B-2TB21
22	89,24	B	1610	14	41,3	25,0	76	0,54	0,31	PHS 08B-2TB22
23	93,27	B	1610	14	41,3	25,0	79	0,66	0,31	PHS 08B-2TB23
24	97,29	B	1610	14	50,8	32,0	84	0,60	0,59	PHS 08B-2TB24
25	101,33	B	2012	14	50,8	32,0	87	0,74	0,59	PHS 08B-2TB25
26	105,36	B	2012	14	50,8	32,0	87	0,81	0,59	PHS 08B-2TB26
27	109,40	B	2012	14	50,8	32,0	87	0,92	0,59	PHS 08B-2TB27
28	113,42	B	2012	14	50,8	32,0	87	1,03	0,59	PHS 08B-2TB28
29	117,46	B	2012	14	50,8	32,0	87	1,16	0,59	PHS 08B-2TB29
30	121,50	B	2012	14	50,8	32,0	87	1,25	0,59	PHS 08B-2TB30
35	141,68	B	2012	14	50,8	32,0	100	1,65	0,59	PHS 08B-2TB35
36	145,72	B	2012	14	50,8	32,0	100	2,05	0,59	PHS 08B-2TB36
38	153,80	B	2012	14	50,8	32,0	100	2,53	0,59	PHS 08B-2TB38
42	169,94	C	2517	16	63,5	32,0	100	3,13	1,30	PHS 08B-2TB42
45	182,07	C	2012	14	50,8	32,0	100	3,73	0,59	PHS 08B-2TB45
48	194,18	C	2517	16	63,5	32,0	100	3,84	1,30	PHS 08B-2TB48
54	218,42	C	2517	16	63,5	32,0	100	3,95	1,30	PHS 08B-2TB54
57	230,53	C	2012	14	50,8	32,0	100	4,07	0,59	PHS 08B-2TB57
60	242,66	C	2517	16	63,5	32,0	100	4,20	1,30	PHS 08B-2TB60
68	274,99	C	2517	16	63,5	32,0	100	4,33	1,30	PHS 08B-2TB68
70	283,07	C	2517	16	63,5	32,0	100	4,46	1,30	PHS 08B-2TB70
72	291,15	C	2517	16	63,5	32,0	100	4,59	1,30	PHS 08B-2TB72
76	307,31	C	2012	14	50,8	32,0	100	4,72	0,59	PHS 08B-2TB76
84	339,65	C	2517	16	63,5	32,0	100	6,45	1,30	PHS 08B-2TB84
95	384,10	C	2012	14	50,8	32,0	100	8,18	0,59	PHS 08B-2TB95
96	388,15	C	2517	16	63,5	32,0	110	9,00	1,30	PHS 08B-2TB96
114	460,90	C	2517	16	63,5	45,0	110	10,50	1,30	PHS 08B-2TB114

For hardened teeth sprockets, add "H" after the sprocket profile e.g. PHS 08B-1AH8.



Metric sprockets



Duplex
Taper Bushed

ISO 10B-2 15,88 mm Pitch

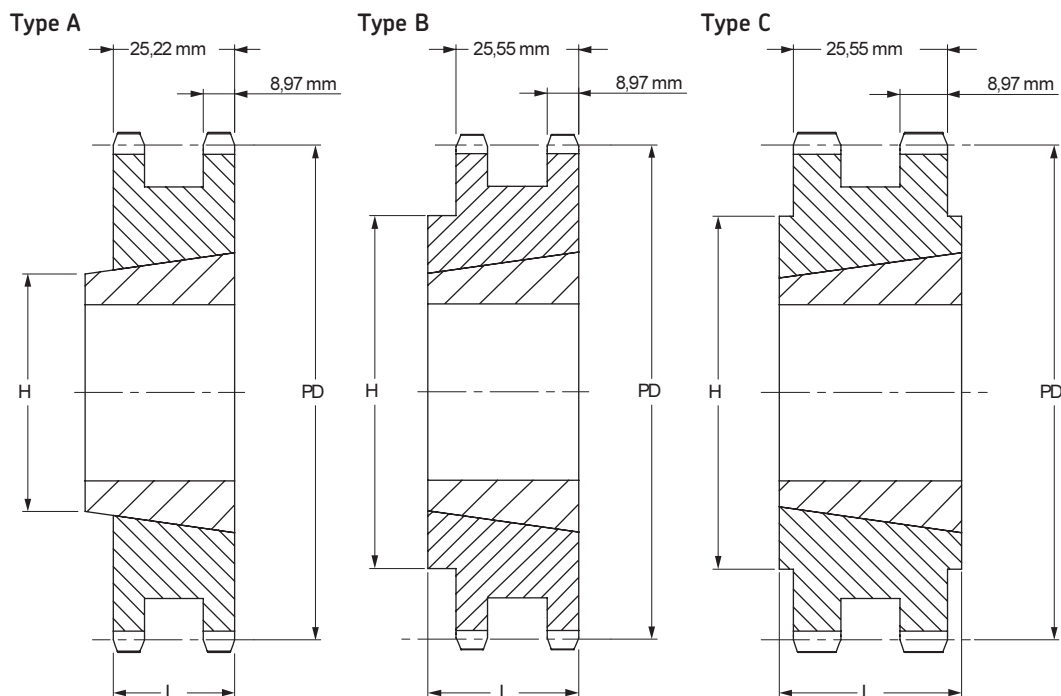

Taper Bushed Type A/B/C

No. Teeth	Pitch Diameter	Type	Bushing Size	Bore		Dimensions		Weight		Designation
				Min	Max	L	H	Rim	Bushing	
	mm			mm	mm	mm	mm	kg	kg	
14	71,34	A	1008	9	25,4	25,5	-	0,43	0,09	PHS 10B-2TB14
15	76,36	A	1210	11	31,8	25,5	-	0,39	0,21	PHS 10B-2TB15
16	81,37	A	1610	14	41,3	25,5	-	0,35	0,31	PHS 10B-2TB16
17	86,39	A	1610	14	41,3	25,5	-	0,46	0,31	PHS 10B-2TB17
18	91,42	A	1610	14	41,3	25,5	-	0,62	0,31	PHS 10B-2TB18
19	96,45	A	1610	14	41,3	25,5	-	0,75	0,31	PHS 10B-2TB19
20	101,49	B	1610	14	41,3	25,5	-	0,87	0,31	PHS 10B-2TB20
21	106,52	B	1610	14	41,3	25,5	-	1,05	0,31	PHS 10B-2TB21
22	111,55	B	1610	14	41,3	25,5	-	1,20	0,31	PHS 10B-2TB22
23	116,58	B	1610	14	41,3	25,5	-	1,38	0,31	PHS 10B-2TB23
24	121,62	B	2012	14	50,8	32,0	90	1,43	0,59	PHS 10B-2TB24
25	126,66	B	2012	14	50,8	32,0	90	1,62	0,59	PHS 10B-2TB25
26	131,70	B	2012	14	50,8	32,0	90	1,79	0,59	PHS 10B-2TB26
27	136,75	B	2012	14	50,8	32,0	90	2,00	0,59	PHS 10B-2TB27
28	141,78	B	2012	14	50,8	32,0	90	2,20	0,59	PHS 10B-2TB28
29	146,83	B	2012	14	50,8	32,0	90	2,43	0,59	PHS 10B-2TB29
30	151,87	B	2012	14	50,8	32,0	90	2,66	0,59	PHS 10B-2TB30
36	182,15	C	2517	16	63,5	45,0	110	4,33	1,30	PHS 10B-2TB36
38	192,24	C	2517	14	50,8	45,0	110	4,88	0,59	PHS 10B-2TB38
42	212,44	C	2517	16	63,5	45,0	110	5,99	1,30	PHS 10B-2TB42
45	227,58	C	2517	16	63,5	45,0	110	6,83	1,30	PHS 10B-2TB45
48	242,73	C	2517	16	63,5	45,0	110	7,66	1,30	PHS 10B-2TB48
57	288,18	C	2517	16	63,5	45,0	110	10,15	1,30	PHS 10B-2TB57
60	303,32	C	2517	16	63,5	45,0	110	10,99	1,30	PHS 10B-2TB60
68	343,74	C	2517	16	63,5	45,0	110	13,21	1,30	PHS 10B-2TB68
76	384,16	C	2517	16	63,5	45,0	110	15,43	1,30	PHS 10B-2TB76
84	424,57	C	2517	16	63,5	45,0	110	17,65	1,30	PHS 10B-2TB84
95	480,14	C	2517	16	63,5	45,0	110	20,70	1,30	PHS 10B-2TB95
114	576,13	C	2517	16	63,5	45,0	110	25,97	1,30	PHS 10B-2TB114

For hardened teeth sprockets, add "H" after the sprocket profile e.g. PHS 08B-1AH8.



Metric sprockets

Duplex

Taper Bushed

- ▶ Belts
- ▶ Chains
- ▶ Couplings
- ▶ Bushings and Hubs
- ▶ Sprockets
- ▶ Pulleys
- ▶ Smart tools

ISO 12B-2 19,05 mm Pitch

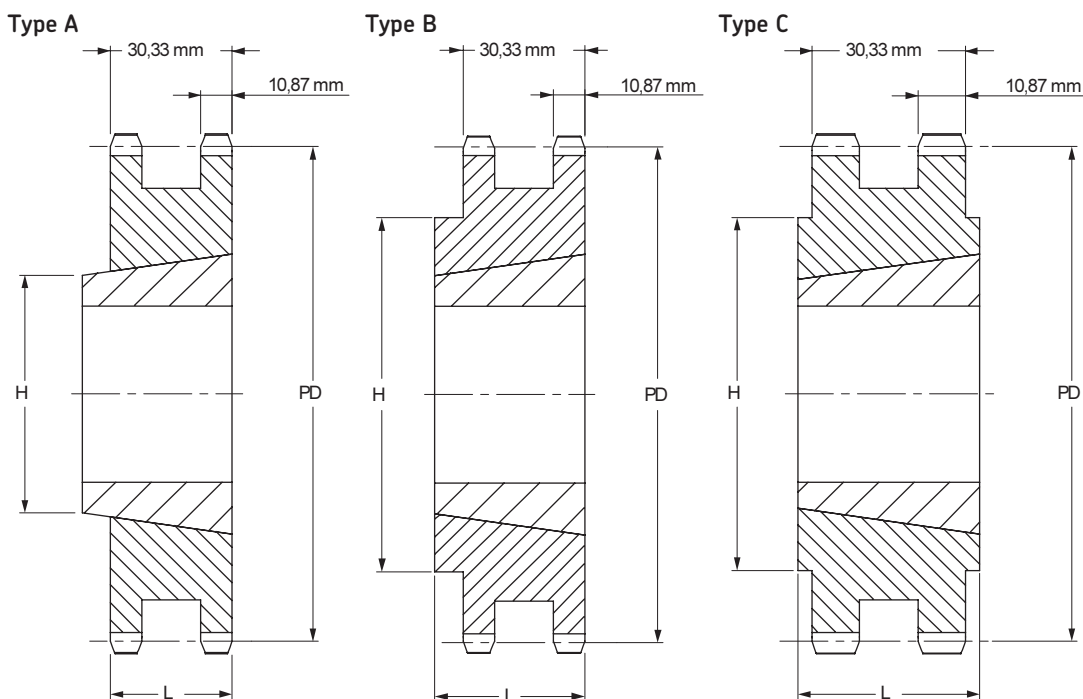

Taper Bushed Type A/B/C

No. Teeth	Pitch Diameter mm	Type	Bushing Size	Bore		Dimensions		Weight		Designation
				Min	Max	L	H	Rim	Bushing	
				mm	mm	mm	mm	kg	kg	
12	73,61	A	1215	11	31,8	30,3	-	0,19	0,30	PHS 12B-2TB12
13	79,59	A	1610	14	41,3	30,3	-	0,36	0,30	PHS 12B-2TB13
14	85,61	A	1610	14	41,3	30,3	-	0,53	0,30	PHS 12B-2TB14
15	91,63	A	1610	14	41,3	30,3	-	0,70	0,31	PHS 12B-2TB15
16	97,65	A	1610	14	41,3	30,3	-	0,87	0,31	PHS 12B-2TB16
17	103,67	A	1610	14	41,3	30,3	-	1,10	0,31	PHS 12B-2TB17
18	109,71	B	2012	14	50,8	31,8	90	1,05	0,59	PHS 12B-2TB18
19	115,75	B	2012	14	50,8	32,0	90	1,29	0,59	PHS 12B-2TB19
20	121,78	B	2517	16	63,5	45,0	102	1,34	1,30	PHS 12B-2TB20
21	127,82	B	2517	16	63,5	45,0	108	1,71	1,30	PHS 12B-2TB21
22	133,86	B	2517	16	63,5	45,0	108	2,03	1,30	PHS 12B-2TB22
23	139,90	B	2517	16	63,5	45,0	108	2,51	1,30	PHS 12B-2TB23
24	145,94	B	2517	16	63,5	45,0	108	2,58	1,30	PHS 12B-2TB24
25	152,00	B	2517	16	63,5	45,0	108	3,38	1,30	PHS 12B-2TB25
26	158,04	B	2517	16	63,5	45,0	108	3,24	1,30	PHS 12B-2TB26
27	164,09	B	2517	16	63,5	45,0	108	4,00	1,30	PHS 12B-2TB27
28	170,13	B	2517	16	63,5	45,0	108	3,92	1,30	PHS 12B-2TB28
30	182,25	B	2517	16	63,5	45,0	108	5,14	1,30	PHS 12B-2TB30
32	194,36	B	2517	16	63,5	44,5	130	5,92	1,30	PHS 12B-2TB32
35	212,52	B	2517	16	63,5	44,5	130	7,08	1,30	PHS 12B-2TB35
38	230,69	B	3020	25	76,2	51,0	140	6,95	2,24	PHS 12B-2TB38
40	242,81	C	3020	25	76,2	51,0	140	9,03	2,24	PHS 12B-2TB40
42	254,93	C	3020	25	76,2	51,0	140	9,81	2,24	PHS 12B-2TB42
45	273,10	C	3020	25	76,2	51,0	140	9,33	2,24	PHS 12B-2TB45
54	327,64	C	3020	25	76,2	51,0	140	14,47	2,24	PHS 12B-2TB54
57	345,81	C	3020	25	76,2	51,0	140	10,50	2,24	PHS 12B-2TB57
60	363,99	C	3020	25	76,2	51,0	140	16,80	2,24	PHS 12B-2TB60
65	394,29	C	3020	25	76,2	51,0	140	18,75	2,24	PHS 12B-2TB65
70	424,60	C	3020	25	76,2	51,0	140	20,69	2,24	PHS 12B-2TB70
76	460,99	C	3020	25	76,2	51,0	140	17,06	2,24	PHS 12B-2TB76
84	509,48	C	3020	25	76,2	51,0	140	26,13	2,24	PHS 12B-2TB84
95	576,17	C	3020	25	76,2	51,0	140	28,50	2,24	PHS 12B-2TB95
114	691,36	C	3020	25	76,2	76,0	140	37,80	2,24	PHS 12B-2TB114

For hardened teeth sprockets, add "H" after the sprocket profile e.g. PHS 08B-1AH8.



Metric sprockets



Duplex
Taper Bushed

ISO 16B-2 25,40 mm Pitch

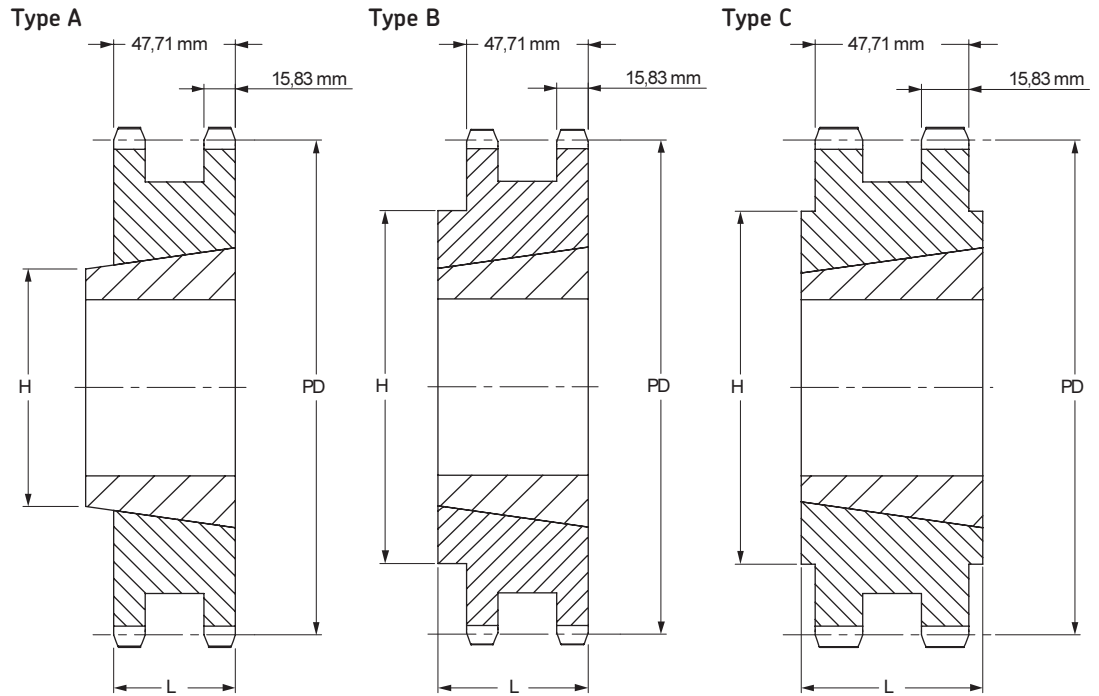

Taper Bushed Type A/B/C

No. Teeth	Pitch Diameter	Type	Bushing Size	Bore		Dimensions		Weight		Designation
				Min	Max	L	H	Rim	Bushing	
	mm			mm	mm	mm	mm	kg	kg	
13	106,12	A	1615	14	42,0	47,7	-	0,51	0,59	PHS 16B-2TB13
14	114,15	A	2012	14	50,8	47,7	-	1,01	0,59	PHS 16B-2TB14
15	122,17	A	2012	14	50,8	47,7	-	2,12	0,59	PHS 16B-2TB15
16	130,20	A	2517	16	63,5	47,7	-	2,01	1,30	PHS 16B-2TB16
17	138,22	A	2517	16	63,5	47,7	-	2,51	1,30	PHS 16B-2TB17
18	146,28	A	2517	16	63,5	47,7	-	3,13	1,30	PHS 16B-2TB18
19	154,33	A	2517	16	63,5	47,7	-	3,76	1,30	PHS 16B-2TB19
20	162,38	B	2517	16	63,5	47,7	140	4,43	1,30	PHS 16B-2TB20
21	170,43	B	3020	25	76,2	51,0	140	4,13	2,24	PHS 16B-2TB21
22	178,48	B	3020	25	76,2	51,0	140	4,95	2,24	PHS 16B-2TB22
23	186,53	B	3020	25	76,2	51,0	140	5,80	2,24	PHS 16B-2TB23
24	194,59	B	3020	25	76,2	51,0	140	6,68	2,24	PHS 16B-2TB24
25	202,66	B	3020	25	76,2	51,0	140	7,65	2,24	PHS 16B-2TB25
26	210,72	B	3020	25	76,2	51,0	140	8,50	2,24	PHS 16B-2TB26
27	218,79	B	3020	25	76,2	51,0	140	9,47	2,24	PHS 16B-2TB27
28	226,85	B	3020	25	76,2	51,0	140	10,46	2,24	PHS 16B-2TB28
29	234,92	B	3020	25	76,2	51,0	140	11,48	2,24	PHS 16B-2TB29
30	243,00	B	3020	25	76,2	51,0	140	12,50	3,04	PHS 16B-2TB30
35	283,36	C	3030	35	76,2	76,0	140	16,36	3,04	PHS 16B-2TB35
38	307,59	C	3020	25	63,5	51,0	140	13,48	3,04	PHS 16B-2TB38
42	339,90	C	3030	35	76,2	76,0	140	22,52	2,24	PHS 16B-2TB42
45	364,13	C	3030	35	76,2	76,0	140	18,30	3,04	PHS 16B-2TB45
57	461,07	C	3525	35	100,0	63,5	175	27,00	3,56	PHS 16B-2TB57
76	614,65	C	3525	35	100,0	63,5	175	43,50	3,56	PHS 16B-2TB76
95	768,22	C	3525	40	101,6	102,0	215	67,00	5,54	PHS 16B-2TB95
114	921,81	C	4040	40	101,6	102,0	215	85,88	5,54	PHS 16B-2TB114

For hardened teeth sprockets, add "H" after the sprocket profile e.g. PHS 08B-1AH8.



Metric sprockets

Triplex
Standard

- ▶ Belts
- ▶ Chains
- ▶ Couplings
- ▶ Bushings and Hubs
- ▶ Sprockets
- ▶ Pulleys
- ▶ Smart tools

ISO 06B-3 9,525 mm Pitch

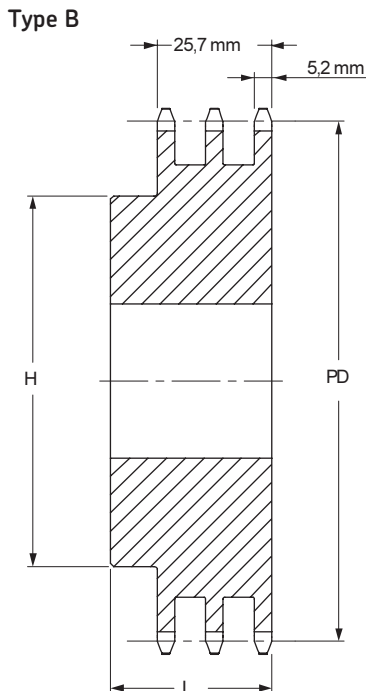

ISO 08B-3 12,70 mm Pitch

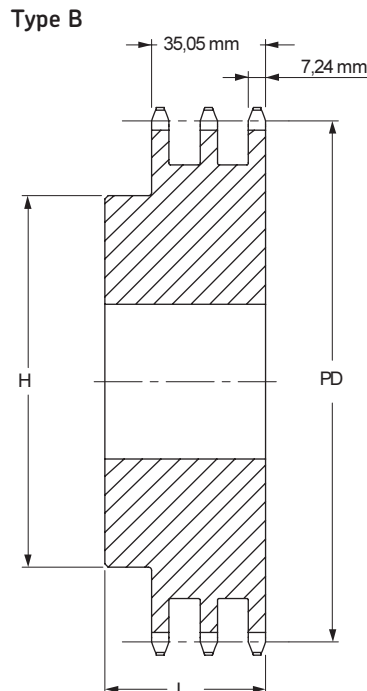

Pilot bore Type B

No. Teeth	Pitch Diameter	Type	Bore		Hub		Weight	Designation
			Min	Max	H	L		
	mm		mm	mm	mm	mm	kg	
12	36,80	B	10	16	25	35	0,23	PHS 06B-3B12
13	39,79	B	10	18	28	35	0,27	PHS 06B-3B13
14	42,80	B	12	18	31	35	0,32	PHS 06B-3B14
15	45,81	B	12	20	34	35	0,36	PHS 06B-3B15
16	48,82	B	12	20	37	35	0,45	PHS 06B-3B16
17	51,83	B	12	24	40	35	0,54	PHS 06B-3B17
18	54,85	B	12	25	43	35	0,64	PHS 06B-3B18
19	57,87	B	12	28	46	35	0,72	PHS 06B-3B19
20	60,89	B	12	30	49	35	0,77	PHS 06B-3B20
21	63,91	B	14	30	52	40	0,86	PHS 06B-3B21
22	66,93	B	14	35	55	40	0,95	PHS 06B-3B22
23	69,95	B	14	38	58	40	1,04	PHS 06B-3B23
24	72,97	B	14	39	61	40	1,18	PHS 06B-3B24
25	76,02	B	14	40	64	40	1,27	PHS 06B-3B25
26	79,02	B	14	42	67	40	1,31	PHS 06B-3B26
27	82,02	B	14	45	70	40	1,36	PHS 06B-3B27
28	85,07	B	14	48	73	40	1,50	PHS 06B-3B28
29	88,09	B	14	50	76	40	1,68	PHS 06B-3B29
30	91,12	B	14	52	79	40	1,72	PHS 06B-3B30
32	97,17	B	16	52	80	40	2,00	PHS 06B-3B32
35	106,26	B	16	52	85	40	2,25	PHS 06B-3B35
36	109,29	B	16	60	90	40	2,33	PHS 06B-3B36
38	115,35	B	16	60	90	40	2,49	PHS 06B-3B38
40	121,40	B	16	60	90	40	2,65	PHS 06B-3B40
42	127,46	B	16	60	90	56	2,81	PHS 06B-3B42
45	136,55	B	16	60	90	56	3,00	PHS 06B-3B45
48	145,64	B	16	60	90	56	3,20	PHS 06B-3B48
52	157,75	B	16	60	90	56	3,46	PHS 06B-3B52
57	172,91	B	16	60	90	56	4,77	PHS 06B-3B57
60	181,99	B	16	60	90	56	5,02	PHS 06B-3B60
68	206,24	B	16	60	90	56	5,69	PHS 06B-3B68
70	212,30	B	16	60	90	56	5,86	PHS 06B-3B70
72	218,37	B	16	60	90	56	6,02	PHS 06B-3B72
76	230,49	B	16	64	90	56	8,48	PHS 06B-3B76
84	254,74	B	16	64	90	56	9,37	PHS 06B-3B84
95	288,08	B	16	64	90	56	13,61	PHS 06B-3B95
96	291,11	B	16	64	90	56	13,75	PHS 06B-3B96
114	345,69	B	16	64	90	56	17,48	PHS 06B-3B114

Maximum bores can accommodate standard keyways. Larger bores are available where a shallow keyway is used or no keyway is required.

For hardened teeth sprockets, add "H" after the sprocket profile e.g. PHS 08B-1AH8.

Pilot bore Type B

No. Teeth	Pitch Diameter	Type	Bore		Hub		Weight	Designation
			Min	Max	H	L		
	mm		mm	mm	mm	mm	kg	
11	45,07	B	14	22	32	50	0,32	PHS 08B-3B11
12	49,07	B	14	24	35	50	0,45	PHS 08B-3B12
13	53,06	B	14	25	38	50	0,59	PHS 08B-3B13
14	57,07	B	14	28	42	50	0,72	PHS 08B-3B14
15	61,09	B	14	31	46	50	0,81	PHS 08B-3B15
16	65,10	B	16	35	50	50	0,90	PHS 08B-3B16
17	69,11	B	16	36	54	50	1,04	PHS 08B-3B17
18	73,14	B	16	38	58	50	1,22	PHS 08B-3B18
19	77,16	B	16	40	62	50	1,41	PHS 08B-3B19
20	81,19	B	16	40	66	50	1,58	PHS 08B-3B20
21	85,22	B	16	45	70	55	1,81	PHS 08B-3B21
22	89,24	B	16	45	70	55	2,03	PHS 08B-3B22
23	93,27	B	16	45	70	55	2,27	PHS 08B-3B23
24	97,29	B	16	50	75	55	2,44	PHS 08B-3B24
25	101,33	B	16	52	80	55	2,54	PHS 08B-3B25
26	105,36	B	20	56	85	55	2,85	PHS 08B-3B26
27	109,40	B	20	56	85	55	2,85	PHS 08B-3B27
28	113,42	B	20	60	90	55	3,16	PHS 08B-3B28
29	117,46	B	20	62	95	55	3,34	PHS 08B-3B29
30	121,50	B	20	64	100	55	3,48	PHS 08B-3B30
35	141,68	B	20	73	110	55	4,79	PHS 08B-3B35
36	145,72	B	25	80	120	55	5,43	PHS 08B-3B36
38	153,80	B	25	80	120	55	6,49	PHS 08B-3B38
42	169,95	B	25	80	120	60	7,17	PHS 08B-3B42
45	182,07	B	25	80	120	60	7,69	PHS 08B-3B45
48	194,18	B	25	80	120	60	8,20	PHS 08B-3B48
52	210,34	B	25	80	120	60	8,88	PHS 08B-3B52
54	218,43	B	25	80	120	60	9,22	PHS 08B-3B54
57	230,54	B	25	80	120	60	12,62	PHS 08B-3B57
60	242,66	B	25	85	120	60	13,84	PHS 08B-3B60
68	274,99	B	25	85	120	60	15,69	PHS 08B-3B68
72	291,16	B	25	85	120	60	16,61	PHS 08B-3B72
76	307,33	B	25	85	120	60	22,23	PHS 08B-3B76
84	339,65	B	25	85	120	60	24,57	PHS 08B-3B84
95	384,11	B	25	85	120	60	33,11	PHS 08B-3B95
114	460,90	B	25	85	120	60	41,90	PHS 08B-3B114

Maximum bores can accommodate standard keyways. Larger bores are available where a shallow keyway is used or no keyway is required.

For hardened teeth sprockets, add "H" after the sprocket profile e.g. PHS 08B-1AH8.



Metric sprockets

Triplex
Standard



ISO 10B-3 15,88 mm Pitch

ISO 12B-3 19,05 mm Pitch

Type B

Type C

Type B

Type C

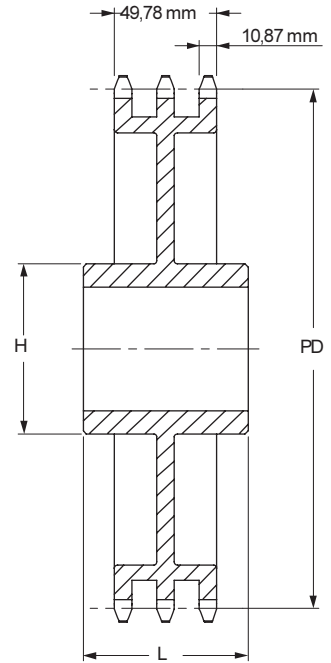
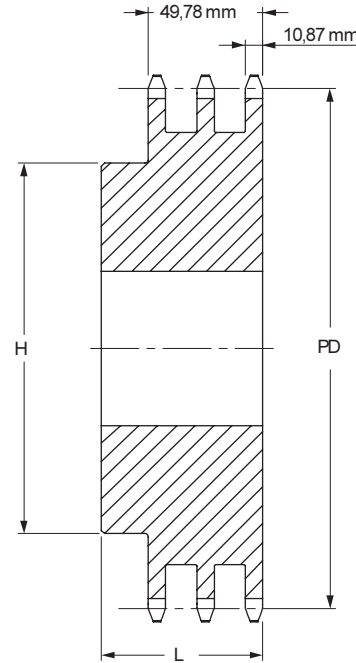
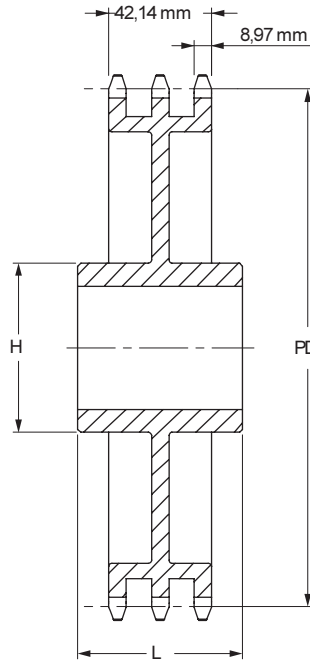
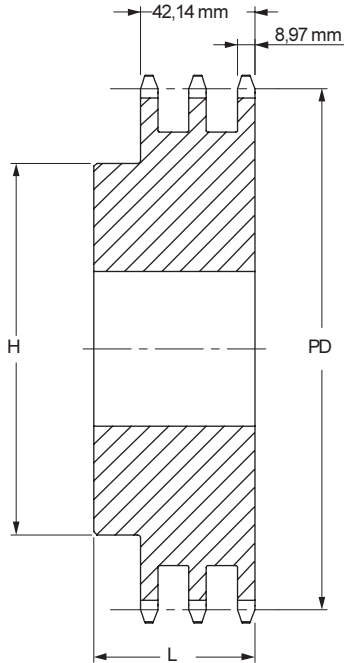

Pilot bore Type B/C

Pilot bore Type B/C

No. Teeth	Pitch Diameter	Type	Bore		Hub		Weight	Designation
			Min	Max	H	L		
	mm		mm	mm	mm	mm	kg	
11	56,34	B	16	24	39	55	0,68	PHS 10B-3B11
12	61,34	B	16	29	44	55	0,82	PHS 10B-3B12
13	66,32	B	16	34	49	55	1,05	PHS 10B-3B13
14	71,34	B	16	35	54	55	1,23	PHS 10B-3B14
15	76,36	B	16	38	59	55	1,36	PHS 10B-3B15
16	81,37	B	16	42	64	60	1,55	PHS 10B-3B16
17	86,38	B	16	45	69	60	1,81	PHS 10B-3B17
18	91,42	B	16	48	74	60	2,09	PHS 10B-3B18
19	96,45	B	16	52	79	60	2,40	PHS 10B-3B19
20	101,49	B	16	56	84	60	2,72	PHS 10B-3B20
21	106,52	B	20	56	85	60	3,04	PHS 10B-3B21
22	111,55	B	20	60	90	60	3,36	PHS 10B-3B22
23	116,58	B	20	62	95	60	3,67	PHS 10B-3B23
24	121,62	B	20	64	100	60	4,00	PHS 10B-3B24
25	126,66	B	20	68	105	60	4,31	PHS 10B-3B25
26	131,70	B	20	73	110	60	5,18	PHS 10B-3B26
27	136,75	B	20	73	110	60	5,63	PHS 10B-3B27
28	141,78	B	20	76	115	60	6,04	PHS 10B-3B28
29	146,83	B	20	76	115	60	6,22	PHS 10B-3B29
30	151,87	B	20	80	120	60	6,36	PHS 10B-3B30
32	161,95	B	20	80	120	60	7,26	PHS 10B-3B32
35	177,10	B	20	80	120	60	8,60	PHS 10B-3B35
36	182,15	B	25	80	120	60	9,34	PHS 10B-3B36
38	192,24	B	25	80	120	60	11,03	PHS 10B-3B38
45	227,58	B	25	80	130	60	14,94	PHS 10B-3B45
48	242,73	B	25	80	130	60	16,62	PHS 10B-3B48
57	288,18	B	25	80	130	64	21,77	PHS 10B-3B57
60	303,32	B	25	80	130	67	22,22	PHS 10B-3B60
76	384,16	C	25	80	130	67	23,13	PHS 10B-3C76
80	404,35	C	25	80	130	67	25,14	PHS 10B-3C80
95	480,14	C	25	80	130	67	32,66	PHS 10B-3C95
114	576,13	C	25	80	130	67	44,76	PHS 10B-3C114

No. Teeth	Pitch Diameter	Type	Bore		Hub		Weight	Designation
			Min	Max	H	L		
	mm		mm	mm	mm	mm	kg	
11	67,61	B	20	32	47	70	1,13	PHS 12B-3B11
12	73,61	B	20	36	53	70	1,50	PHS 12B-3B12
13	79,59	B	20	38	59	70	1,77	PHS 12B-3B13
14	85,61	B	20	42	65	70	2,04	PHS 12B-3B14
15	91,63	B	20	45	71	70	2,45	PHS 12B-3B15
16	97,65	B	20	51	77	70	2,95	PHS 12B-3B16
17	103,67	B	20	54	83	70	3,49	PHS 12B-3B17
18	109,71	B	20	60	89	70	3,86	PHS 12B-3B18
19	115,75	B	20	62	95	70	4,54	PHS 12B-3B19
20	121,78	B	20	64	100	70	5,08	PHS 12B-3B20
21	127,82	B	20	64	100	70	5,67	PHS 12B-3B21
22	133,86	B	20	64	100	70	5,99	PHS 12B-3B22
23	139,90	B	20	73	110	70	6,62	PHS 12B-3B23
24	145,94	B	20	73	110	70	7,17	PHS 12B-3B24
25	152,00	B	20	80	120	70	7,71	PHS 12B-3B25
26	158,04	B	20	80	120	70	8,44	PHS 12B-3B26
27	164,09	B	20	80	120	70	8,99	PHS 12B-3B27
28	170,13	B	20	80	120	70	9,49	PHS 12B-3B28
29	176,19	B	20	80	120	70	9,99	PHS 12B-3B29
30	182,25	B	20	80	120	70	10,53	PHS 12B-3B30
35	212,52	B	25	85	130	70	18,95	PHS 12B-3B35
36	218,58	B	25	85	130	70	19,49	PHS 12B-3B36
38	230,69	B	25	85	130	70	20,57	PHS 12B-3B38
45	273,10	B	25	85	140	70	24,36	PHS 12B-3B45
48	291,27	B	25	85	140	70	25,98	PHS 12B-3B48
57	345,81	B	25	82	140	70	33,73	PHS 12B-3B57
60	363,99	C	25	82	140	70	35,51	PHS 12B-3C60
68	412,49	C	25	82	140	70	40,24	PHS 12B-3C68
76	460,99	C	25	95	140	70	37,19	PHS 12B-3C76
80	485,22	C	25	95	140	70	39,15	PHS 12B-3C80
95	576,17	C	25	95	140	70	47,63	PHS 12B-3C95

Maximum bores can accommodate standard keyways. Larger bores are available where a shallow keyway is used or no keyway is required.

For hardened teeth sprockets, add "H" after the sprocket profile e.g. PHS 08B-1AH8.

Maximum bores can accommodate standard keyways. Larger bores are available where a shallow keyway is used or no keyway is required.

For hardened teeth sprockets, add "H" after the sprocket profile e.g. PHS 08B-1AH8.

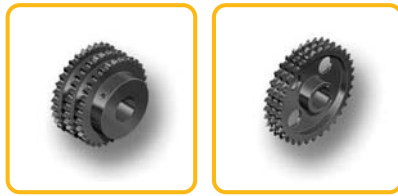

Metric sprockets

Triplex
Standard

- ▶ Belts
- ▶ Chains
- ▶ Couplings
- ▶ Bushings and Hubs
- ▶ Sprockets
- ▶ Pulleys
- ▶ Smart tools

ISO 16B-3 25,40 mm Pitch

ISO 20B-3 31,75 mm Pitch

Type B

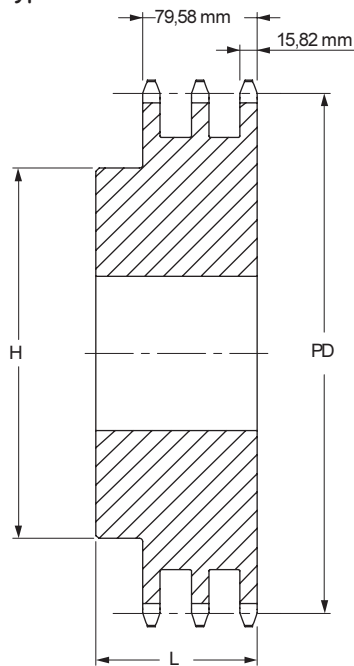

Type C

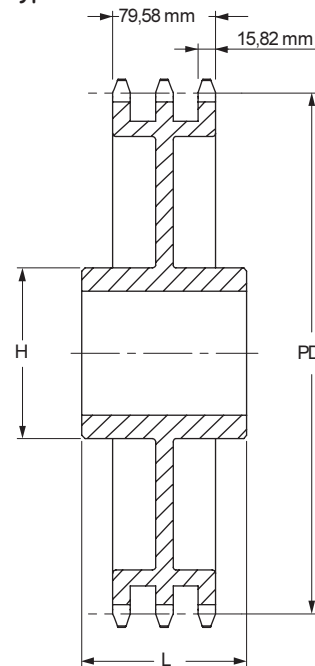

Type B

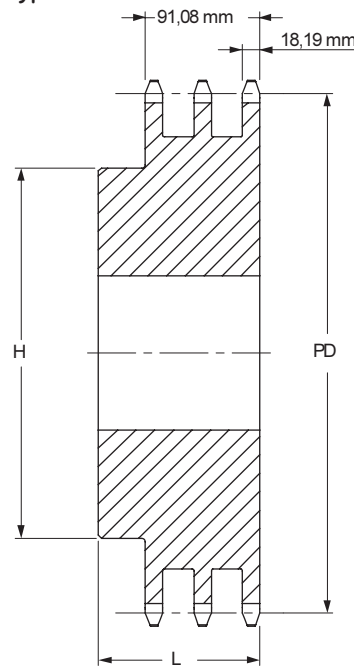

Type C

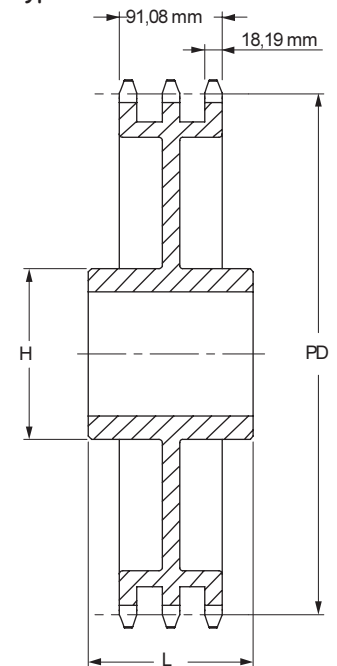

Pilot bore Type B/C

Pilot bore Type B/C

No. Teeth	Pitch Diameter	Type	Bore		Hub		Weight	Designation
			Min	Max	H	L		
			mm	mm	mm	mm		
10	90,14	B	20	42	56	95	1,85	PHS 16B-3B10
11	90,14	B	25	42	64	100	3,59	PHS 16B-3B11
12	98,14	B	25	45	72	100	3,59	PHS 16B-3B12
13	106,12	B	25	52	80	100	4,13	PHS 16B-3B13
14	114,15	B	25	58	88	100	4,68	PHS 16B-3B14
15	122,17	B	25	62	96	100	5,54	PHS 16B-3B15
16	130,20	B	25	66	104	100	6,81	PHS 16B-3B16
17	138,22	B	25	74	112	100	8,07	PHS 16B-3B17
18	146,28	B	25	80	120	100	9,99	PHS 16B-3B18
19	154,33	B	25	84	128	100	10,89	PHS 16B-3B19
20	162,38	B	25	85	130	100	11,80	PHS 16B-3B20
21	170,43	B	25	85	130	100	13,61	PHS 16B-3B21
22	178,48	B	25	85	130	100	14,07	PHS 16B-3B22
23	186,53	B	25	85	130	100	14,97	PHS 16B-3B23
24	194,59	B	25	85	130	100	16,34	PHS 16B-3B24
25	202,66	B	25	85	130	100	17,70	PHS 16B-3B25
26	210,72	B	30	85	130	100	19,98	PHS 16B-3B26
27	218,79	B	30	85	130	100	21,57	PHS 16B-3B27
28	226,85	B	30	85	130	100	23,15	PHS 16B-3B28
29	234,92	B	30	85	130	100	24,74	PHS 16B-3B29
30	243,00	B	30	95	136	100	26,33	PHS 16B-3B30
35	283,36	B	30	95	140	100	36,06	PHS 16B-3B35
36	291,44	B	30	95	140	100	38,06	PHS 16B-3B36
38	307,59	C	30	97	140	100	38,22	PHS 16B-3C38
42	339,89	C	30	97	160	100	38,51	PHS 16B-3C42
45	364,13	C	30	97	160	100	41,77	PHS 16B-3C45
57	461,07	C	30	107	180	110	54,80	PHS 16B-3C57
60	485,32	C	30	107	180	110	58,06	PHS 16B-3C60
68	549,98	C	30	107	180	110	63,50	PHS 16B-3C68
76	614,65	C	30	107	180	110	74,52	PHS 16B-3C76
95	768,22	C	30	114	180	110	100,70	PHS 16B-3C95
114	921,81	C	30	114	180	110	120,84	PHS 16B-3C114

No. Teeth	Pitch Diameter	Type	Bore		Hub		Weight	Designation
			Min	Max	H	L		
			mm	mm	mm	mm		
10	102,75	B	20	47	70	110	3,95	PHS 20B-3B10
11	112,70	B	20	52	80	115	5,26	PHS 20B-3B11
12	122,67	B	20	60	90	115	6,21	PHS 20B-3B12
13	132,67	B	20	64	100	115	9,26	PHS 20B-3B13
14	142,68	B	20	73	110	115	9,76	PHS 20B-3B14
15	152,71	B	20	80	120	115	10,81	PHS 20B-3B15
16	162,75	B	25	80	120	115	12,76	PHS 20B-3B16
17	172,79	B	25	80	120	115	14,76	PHS 20B-3B17
18	182,84	B	25	80	120	115	16,71	PHS 20B-3B18
19	192,90	B	25	80	120	115	19,13	PHS 20B-3B19
20	202,96	B	25	80	120	115	21,57	PHS 20B-3B20
21	213,03	B	25	92	140	115	23,36	PHS 20B-3B21
22	223,10	B	25	92	140	115	25,65	PHS 20B-3B22
23	233,17	B	25	92	140	115	27,90	PHS 20B-3B23
24	243,25	B	25	95	140	115	27,19	PHS 20B-3B24
25	253,32	B	25	95	140	115	27,90	PHS 20B-3B25
26	263,41	B	25	95	150	115	31,90	PHS 20B-3B26
27	273,49	B	25	95	150	115	35,90	PHS 20B-3B27
28	283,57	B	25	95	150	115	39,90	PHS 20B-3B28
30	303,75	B	25	95	150	115	47,90	PHS 20B-3B30
32	323,92	B	30	95	150	115	51,57	PHS 20B-3B32
35	354,20	C	30	97	150	115	57,29	PHS 20B-3C35
36	364,29	C	30	97	150	115	59,35	PHS 20B-3C36
38	384,48	C	30	97	150	115	62,56	PHS 20B-3C38
42	424,86	C	30	97	160	110	70,12	PHS 20B-3C42
45	455,15	C	30	97	160	110	75,84	PHS 20B-3C45
57	576,35	C	30	102	180	123	100,11	PHS 20B-3C57
60	606,66	C	30	102	180	123	104,86	PHS 20B-3C60
68	687,48	C	30	102	200	123	117,54	PHS 20B-3C68
76	768,30	C	30	102	200	123	130,21	PHS 20B-3C76
80	808,71	C	30	102	200	123	136,55	PHS 20B-3C80
95	960,28	C	30	102	200	123	160,31	PHS 20B-3C95
114	1152,27	C	30	102	200	126	190,41	PHS 20B-3C114

Maximum bores can accommodate standard keyways. Larger bores are available where a shallow keyway is used or no keyway is required.

For hardened teeth sprockets, add "H" after the sprocket profile e.g. PHS 08B-1AH8.

Maximum bores can accommodate standard keyways. Larger bores are available where a shallow keyway is used or no keyway is required.

For hardened teeth sprockets, add "H" after the sprocket profile e.g. PHS 08B-1AH8.



Metric sprockets



Triplex
Taper Bushed

ISO 12B-3 19,05 mm Pitch

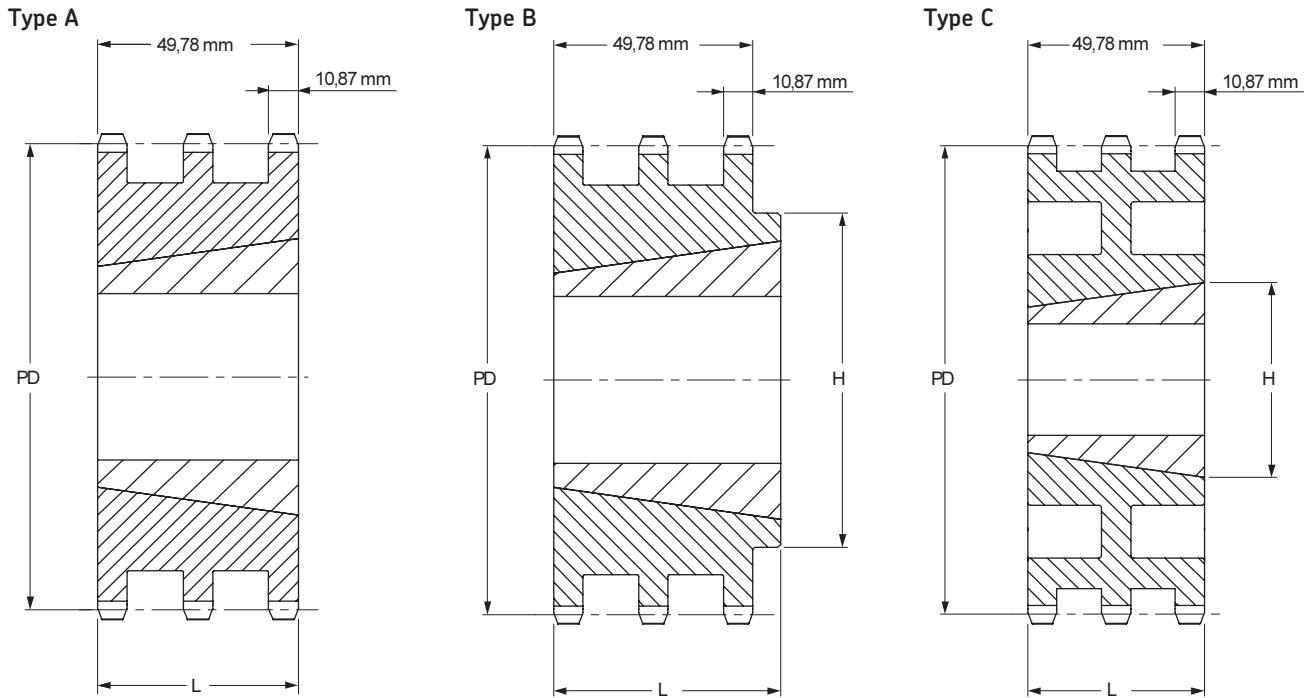

Taper Bushed Type A/B/C

No. Teeth	Pitch Diameter mm	Type	Bushing Size	Bore		Hub		Weight kg	Designation
				Min mm	Max mm	L mm	H mm		
17	103,67	A	2012	14	50	-	-	1,28	PHS 12B-3TB17
19	115,75	A	2517	16	65	-	-	2,02	PHS 12B-3TB19
21	127,82	A	2517	16	65	-	-	2,09	PHS 12B-3TB21
23	139,90	A	2517	16	65	-	-	3,00	PHS 12B-3TB23
25	152,00	A	3020	25	75	-	-	3,97	PHS 12B-3TB25
27	164,09	B	3020	25	75	140	51	3,83	PHS 12B-3TB27
30	182,25	B	3020	25	75	140	51	5,72	PHS 12B-3TB30
38	230,69	B	3020	25	75	140	51	7,76	PHS 12B-3TB38
45	273,10	C	3020	25	75	140	51	10,04	PHS 12B-3TB45
57	345,81	C	3020	25	75	140	51	14,42	PHS 12B-3TB57
76	460,99	C	3020	25	75	140	51	25,50	PHS 12B-3TB76
95	576,17	C	3030	25	75	140	76	36,58	PHS 12B-3TB95
114	691,36	C	3030	25	75	140	76	47,66	PHS 12B-3TB114

Maximum bores can accommodate standard keyways. Larger bores are available where a shallow keyway is used or no keyway is required.

For hardened teeth sprockets, add "H" after the sprocket profile e.g. PHS 08B-1AH8.



Metric sprockets

Triplex

Taper Bushed

- ▶ Belts
- ▶ Chains
- ▶ Couplings
- ▶ Bushings and Hubs
- ▶ Sprockets
- ▶ Pulleys
- ▶ Smart tools

ISO 16B-3 25,40 mm Pitch

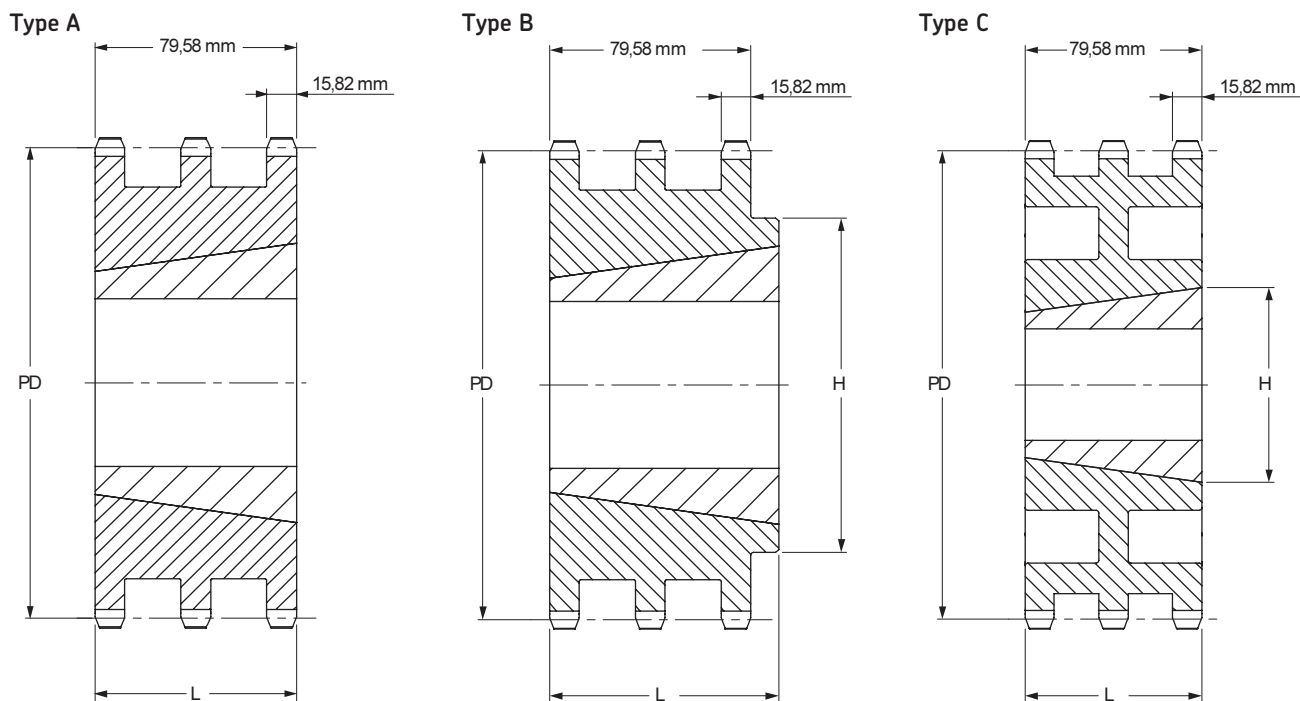

Taper Bushed Type A/B/C

No. Teeth	Pitch Diameter	Type	Bushing Size	Bore		Hub		Weight	Designation
				Min	Max	L	H		
	mm			mm	mm	mm	mm	kg	
17	138,22	A	2517	16	65	-	-	4,20	PHS 16B-3TB17
19	154,33	B	3020	35	75	-	76,2	4,30	PHS 16B-3TB19
21	170,43	B	3020	35	75	-	76,2	6,60	PHS 16B-3TB21
23	186,53	B	3525	35	100	-	65,0	7,00	PHS 16B-3TB23
25	202,66	B	3525	35	100	-	65,0	9,80	PHS 16B-3TB25
27	218,79	B	3525	35	100	-	65,0	12,80	PHS 16B-3TB27
30	243,00	B	3525	35	100	-	65,0	18,00	PHS 16B-3TB30
38	307,59	B	3535	35	100	178	89,0	21,50	PHS 16B-3TB38
45	364,13	C	4040	40	115	216	102,0	33,50	PHS 16B-3TB45
57	461,07	C	4040	40	115	216	102,0	39,50	PHS 16B-3TB57
76	614,65	C	4040	40	115	216	102,0	59,50	PHS 16B-3TB76

Maximum bores can accommodate standard keyways. Larger bores are available where a shallow keyway is used or no keyway is required.

For hardened teeth sprockets, add "H" after the sprocket profile e.g. PHS 08B-1AH8.

ANSI sprockets

Simplex
Pilot Bore



ANSI 25-1 1/4" Pitch

Type A

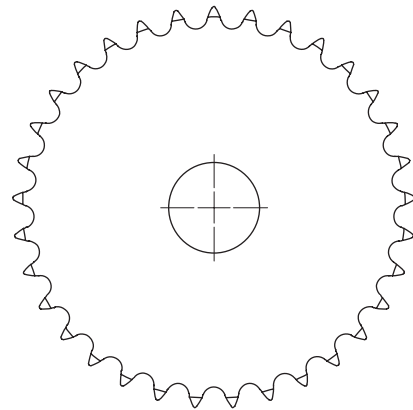
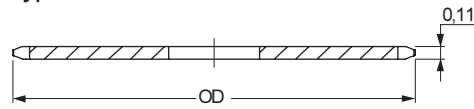

Type B

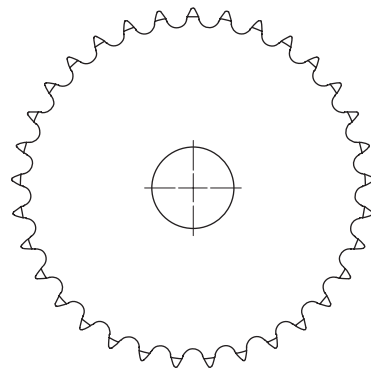
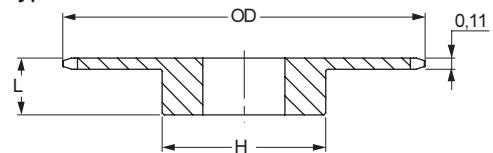

Pilot Bore Type B

Type A

No. Teeth	Outside Diameter	Type	Bore		Hub		Weight	Designation	No. Teeth	Outside Diameter	Type	Bore Stock	Weight	Designation		
			Min	Max	H	L									Inch	lbs
			Inch	Inch	Inch	Inch									Inch	lbs
9	0.84	B	1/4	1/4	7/16	1/2	0.03	PHS 25-1B9	9	0.84	-	-	-	-		
10	0.92	B	1/4	1/4	1/2	1/2	0.03	PHS 25-1B10	10	0.92	-	-	-	-		
11	1.00	B	1/4	5/16	9/16	1/2	0.04	PHS 25-1B11	11	1.00	-	-	-	-		
12	1.08	B	1/4	3/8	5/8	1/2	0.06	PHS 25-1B12	12	1.08	-	-	-	-		
13	1.17	B	1/4	7/16	23/32	1/2	0.07	PHS 25-1B13	13	1.17	-	-	-	-		
14	1.25	B	1/4	9/16	13/16	1/2	0.08	PHS 25-1B14	14	1.25	-	-	-	-		
15	1.33	B	1/4	5/8	57/64	1/2	0.10	PHS 25-1B15	15	1.33	-	-	-	-		
16	1.41	B	1/4	3/4	31/32	1/2	0.12	PHS 25-1B16	16	1.41	-	-	-	-		
17	1.49	B	1/4	5/8	1 1/32	1/2	0.14	PHS 25-1B17	17	1.49	-	-	-	-		
18	1.57	B	1/4	3/4	1 1/8	1/2	0.16	PHS 25-1B18	18	1.57	A	1/4	0.04	PHS 25-1A18		
19	1.65	B	1/4	13/16	1 1/32	1/2	0.19	PHS 25-1B19	19	1.65	A	1/4	0.04	PHS 25-1A19		
20	1.73	B	1/4	7/8	1 1/32	5/8	0.25	PHS 25-1B20	20	1.73	A	1/4	0.04	PHS 25-1A20		
21	1.81	B	1/4	7/8	1 3/8	5/8	0.28	PHS 25-1B21	21	1.81	A	3/8	0.04	PHS 25-1A21		
22	1.89	B	1/4	15/16	1 7/16	5/8	0.31	PHS 25-1B22	22	1.89	A	3/8	0.06	PHS 25-1A22		
23	1.97	B	1/4	1	1 1/2	5/8	0.32	PHS 25-1B23	23	1.97	A	3/8	0.06	PHS 25-1A23		
24	2.05	B	3/8	1	1 1/2	5/8	0.33	PHS 25-1B24	24	2.05	A	3/8	0.08	PHS 25-1A24		
25	2.13	B	3/8	1	1 1/2	5/8	0.34	PHS 25-1B25	25	2.13	A	3/8	0.08	PHS 25-1A25		
26	2.21	B	3/8	1	1 1/2	5/8	0.35	PHS 25-1B26	26	2.21	A	3/8	0.09	PHS 25-1A26		
28	2.37	B	3/8	1	1 1/2	5/8	0.36	PHS 25-1B28	28	2.37	A	3/8	0.10	PHS 25-1A28		
30	2.53	B	3/8	1	1 1/2	5/8	0.38	PHS 25-1B30	30	2.53	A	3/8	0.12	PHS 25-1A30		
32	2.69	B	3/8	1	1 1/2	5/8	0.40	PHS 25-1B32	32	2.69	A	3/8	0.14	PHS 25-1A32		
35	2.93	-	-	-	-	-	-	-	35	2.93	A	3/4	0.16	PHS 25-1A35		
36	3.01	B	3/8	1	1 1/2	3/4	0.50	PHS 25-1B36	36	3.01	A	3/8	0.18	PHS 25-1A36		
40	3.33	B	1/2	1 3/8	2	3/4	0.53	PHS 25-1B40	40	3.33	A	1/2	0.20	PHS 25-1A40		
42	3.49	-	-	-	-	-	-	-	42	3.49	A	1/2	0.24	PHS 25-1A42		
45	3.73	B	1/2	1 3/8	2	3/4	0.56	PHS 25-1B45	45	3.73	A	1/2	0.25	PHS 25-1A45		
48	3.96	B	1/2	1 3/8	2	3/4	0.56	PHS 25-1B48	48	3.96	A	1/2	0.32	PHS 25-1A48		
54	4.44	B	1/2	1 3/8	2	3/4	1.00	PHS 25-1B54	54	4.44	A	1/2	0.38	PHS 25-1A54		
60	4.92	B	1/2	1 3/8	2	3/4	1.10	PHS 25-1B60	60	4.92	A	1/2	0.54	PHS 25-1A60		
70	5.72	B	1/2	1 3/8	2	3/4	1.25	PHS 25-1B70	70	5.72	-	-	-	-		
72	5.88	B	1/2	1 3/8	2	3/4	1.30	PHS 25-1B72	72	5.88	A	1/2	0.74	PHS 25-1A72		

Maximum bores can accommodate standard keyways. Larger bores are available where a shallow keyway is used or no keyway is required.

For hardened teeth sprockets, add "H" after the sprocket profile e.g. PHS 08B-1AH8.



ANSI sprockets

Simplex

Pilot Bore

- ▶ Belts
- ▶ Chains
- ▶ Couplings
- ▶ Bushings and Hubs
- ▶ Sprockets
- ▶ Pulleys
- ▶ Smart tools

ANSI 35-1 3/8" Pitch

Type A

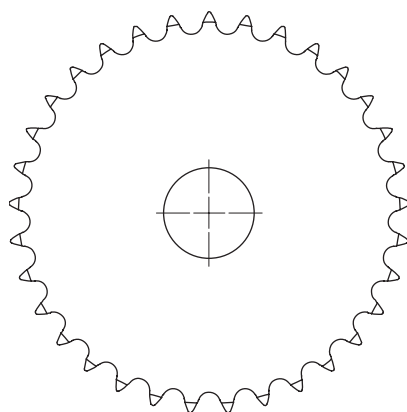
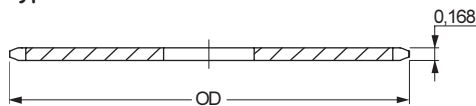

Type B

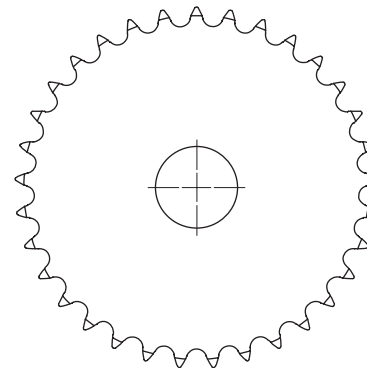
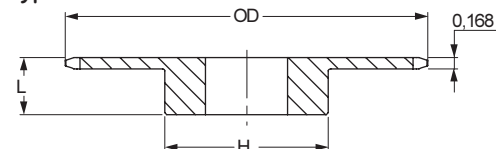

Pilot Bore Type B

Type A

No. Teeth	Outside Diameter	Type	Bore		Hub		Weight	Designation	No. Teeth	Outside Diameter	Type	Bore Stock	Weight	Designation		
			Min	Max	H	L									Inch	lbs
			Inch	Inch	Inch	Inch									Inch	lbs
8	1.13	B	3/8	3/8	3/4	0.07	PHS 35-1B8	8	1.13	-	-	-	-	-		
9	1.26	B	3/8	3/8	27/32	0.09	PHS 35-1B9	9	1.26	-	-	-	-	-		
10	1.38	B	3/8	9/16	31/32	0.14	PHS 35-1B10	10	1.38	-	-	-	-	-		
11	1.50	B	3/8	9/16	1 1/16	0.17	PHS 35-1B11	11	1.50	-	-	-	-	-		
12	1.63	B	1/2	9/16	1 7/32	0.20	PHS 35-1B12	12	1.63	-	-	-	-	-		
13	1.75	B	1/2	11/16	1 1/4	0.23	PHS 35-1B13	13	1.75	-	-	-	-	-		
14	1.87	B	1/2	7/8	1 1/4	0.25	PHS 35-1B14	14	1.87	-	-	-	-	-		
15	1.99	B	1/2	7/8	1 15/32	0.29	PHS 35-1B15	15	1.99	A	1/2	0.10	-	PHS 35-1A15		
16	2.11	B	1/2	15/16	1 15/32	0.35	PHS 35-1B16	16	2.11	A	1/2	0.12	-	PHS 35-1A16		
17	2.23	B	1/2	1 1/16	1 39/32	0.42	PHS 35-1B17	17	2.23	A	3/2	0.12	-	PHS 35-1A17		
18	2.35	B	1/2	1 3/16	1 23/32	0.48	PHS 35-1B18	18	2.35	A	1/2	0.14	-	PHS 35-1A18		
19	2.47	B	1/2	1 1/4	1 27/32	0.54	PHS 35-1B19	19	2.47	A	1/2	0.16	-	PHS 35-1A19		
20	2.59	B	1/2	1 5/16	1 15/16	0.59	PHS 35-1B20	20	2.59	A	1/2	0.20	-	PHS 35-1A20		
21	2.71	B	1/2	1 3/8	2 1/8	0.80	PHS 35-1B21	21	2.71	A	1/2	0.20	-	PHS 35-1A21		
22	2.83	B	1/2	1 3/8	2 7/8	0.80	PHS 35-1B22	22	2.83	A	1/2	0.22	-	PHS 35-1A22		
23	2.95	B	1/2	1 3/8	2 7/8	0.82	PHS 35-1B23	23	2.95	A	1/2	0.24	-	PHS 35-1A23		
24	3.07	B	1/2	1 3/8	2 7/8	0.88	PHS 35-1B24	24	3.07	A	1/2	0.26	-	PHS 35-1A24		
25	3.19	B	1/2	1 3/8	2 7/8	0.88	PHS 35-1B25	25	3.19	A	1/2	0.28	-	PHS 35-1A25		
26	3.31	B	1/2	1 3/8	2 7/8	0.90	PHS 35-1B26	26	3.31	A	1/2	0.28	-	PHS 35-1A26		
27	3.43	B	1/2	1 3/8	2 7/8	0.94	PHS 35-1B27	27	3.43	A	3/2	0.34	-	PHS 35-1A27		
28	3.55	B	1/2	1 3/8	2 7/8	0.94	PHS 35-1B28	28	3.55	A	1/2	0.34	-	PHS 35-1A28		
30	3.79	B	1/2	1 3/8	2 7/8	1.02	PHS 35-1B30	30	3.79	A	1/2	0.46	-	PHS 35-1A30		
32	4.03	B	1/2	1 3/8	2 7/8	1.24	PHS 35-1B32	32	4.03	A	5/8	0.46	-	PHS 35-1A32		
35	4.39	B	5/8	1 1/2	2 1/4	1.50	PHS 35-1B35	35	4.39	A	5/8	0.60	-	PHS 35-1A35		
36	4.51	B	5/8	1 1/2	2 1/4	1.56	PHS 35-1B36	36	4.51	A	5/8	0.62	-	PHS 35-1A36		
40	4.99	B	5/8	1 1/2	2 1/4	1.62	PHS 35-1B40	40	4.99	A	19/32	0.70	-	PHS 35-1A40		
42	5.23	B	5/8	1 1/2	2 1/4	1.68	PHS 35-1B42	42	5.23	A	19/32	0.78	-	PHS 35-1A42		
45	5.59	B	5/8	1 1/2	2 1/4	1.78	PHS 35-1B45	45	5.59	A	19/32	0.88	-	PHS 35-1A45		
48	5.95	B	5/8	1 1/2	2 1/4	1.88	PHS 35-1B48	48	5.95	A	19/32	1.21	-	PHS 35-1A48		
54	6.66	B	5/8	1 1/2	2 1/4	2.20	PHS 35-1B54	54	6.66	A	19/32	1.32	-	PHS 35-1A54		
60	7.38	B	3/4	1 1/2	2 1/4	2.48	PHS 35-1B60	60	7.38	A	23/32	1.66	-	PHS 35-1A60		
70	8.58	B	3/4	1 1/2	2 1/4	3.12	PHS 35-1B70	70	8.58	A	23/32	2.30	-	PHS 35-1A70		
72	8.81	B	3/4	1 1/2	2 1/4	3.42	PHS 35-1B72	72	8.81	A	23/32	2.56	-	PHS 35-1A72		
80	9.77	B	3/4	1 1/2	2 1/4	3.82	PHS 35-1B80	80	9.77	A	23/32	3.16	-	PHS 35-1A80		
84	10.25	B	3/4	1 1/2	2 1/4	4.24	PHS 35-1B84	84	10.25	A	23/32	3.26	-	PHS 35-1A84		
96	11.68	B	3/4	1 1/2	2 1/4	5.16	PHS 35-1B96	96	11.68	A	23/32	4.64	-	PHS 35-1A96		
112	13.59	B	3/4	1 1/2	2 1/4	6.70	PHS 35-1B112	112	13.59	A	23/32	5.05	-	PHS 35-1A112		

Maximum bores can accommodate standard keyways. Larger bores are available where a shallow keyway is used or no keyway is required.

For hardened teeth sprockets, add "H" after the sprocket profile e.g. PHS 08B-1AH8.



ANSI sprockets



Simplex
Pilot Bore

ANSI 41-1 1/2" Pitch

Type A

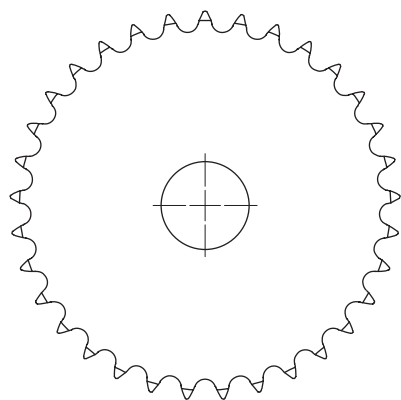
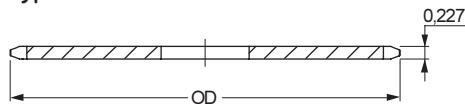

Type B

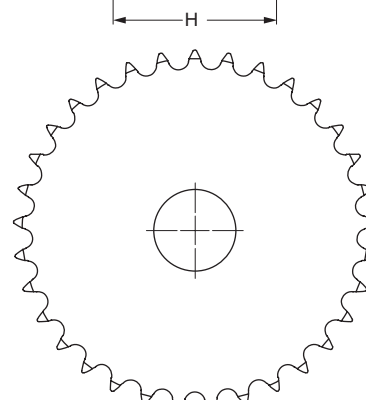
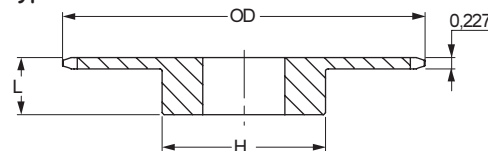

Pilot Bore Type B

Type A

No. Teeth	Outside Diameter	Type	Bore		Hub		Weight	Designation	No. Teeth	Outside Diameter	Type	Bore Stock	Weight	Designation		
			Min	Max	H	L									Inch	lbs
			Inch	Inch	Inch	Inch									Inch	lbs
6	1.17	B	3/8	3/8	21/32	7/8	0.07	PHS 41-1B6	6	1.17	-	-	-	-		
7	1.34	B	3/8	3/8	3/4	7/8	0.10	PHS 41-1B7	7	1.34	-	-	-	-		
8	1.51	B	1/2	1/2	63/64	7/8	0.19	PHS 41-1B8	8	1.51	-	-	-	-		
9	1.67	B	1/2	5/8	1 1/8	7/8	0.20	PHS 41-1B9	9	1.67	-	-	-	-		
10	1.84	B	1/2	3/4	1 1/4	7/8	0.27	PHS 41-1B10	10	1.84	-	-	-	-		
11	2.00	B	1/2	7/8	1 7/16	7/8	0.35	PHS 41-1B11	11	2.00	-	-	-	-		
12	2.17	B	1/2	15/16	1 9/16	7/8	0.44	PHS 41-1B12	12	2.17	-	-	-	-		
13	2.33	B	1/2	1	1 9/16	7/8	0.50	PHS 41-1B13	13	2.33	-	-	-	-		
14	2.49	B	1/2	1 1/4	1 3/4	7/8	0.57	PHS 41-1B14	14	2.49	-	-	-	-		
15	2.65	B	1/2	1 5/16	1 38/32	7/8	0.72	PHS 41-1B15	15	2.65	A	5/8	0.28	PHS 41-1A15		
16	2.81	B	5/8	1 3/8	2 1/16	7/8	0.91	PHS 41-1B16	16	2.81	A	5/8	0.34	PHS 41-1A16		
17	2.97	B	5/8	1 1/2	2 25/64	1	1.09	PHS 41-1B17	17	2.97	A	5/8	0.36	PHS 41-1A17		
18	3.14	B	5/8	1 5/8	2 3/8	1	1.25	PHS 41-1B18	18	3.14	A	5/8	0.44	PHS 41-1A18		
19	3.30	B	5/8	1 3/4	2 15/32	1	1.49	PHS 41-1B19	19	3.30	A	5/8	0.46	PHS 41-1A19		
20	3.46	B	5/8	1 7/8	2 3/4	1	1.64	PHS 41-1B20	20	3.46	A	5/8	0.52	PHS 41-1A20		
21	3.62	B	5/8	1 7/8	2 7/8	1	1.81	PHS 41-1B21	21	3.62	A	5/8	0.60	PHS 41-1A21		
22	3.78	B	5/8	2	3	1	1.93	PHS 41-1B22	22	3.78	A	5/8	0.66	PHS 41-1A22		
23	3.94	B	5/8	2 1/4	3 3/16	1	2.25	PHS 41-1B23	23	3.94	A	5/8	0.72	PHS 41-1A23		
24	4.10	B	5/8	2 1/4	3 3/4	1	2.33	PHS 41-1B24	24	4.10	A	5/8	0.82	PHS 41-1A24		
25	4.26	B	5/8	2 3/4	3 3/4	1	2.46	PHS 41-1B25	25	4.26	A	5/8	0.88	PHS 41-1A25		
26	4.42	B	5/8	2 3/4	3 3/4	1	2.50	PHS 41-1B26	26	4.42	A	5/8	0.94	PHS 41-1A26		
27	4.58	B	5/8	2 3/4	3 3/4	1	2.56	PHS 41-1B27	27	4.58	A	5/8	1.00	PHS 41-1A27		
28	4.74	B	5/8	2 3/4	3 3/4	1	2.64	PHS 41-1B28	28	4.74	A	5/8	1.08	PHS 41-1A28		
30	5.06	B	5/8	2 3/4	3 3/4	1	2.80	PHS 41-1B30	30	5.06	A	19/32	1.20	PHS 41-1A30		
32	5.38	B	5/8	2 3/4	3 3/4	1	2.96	PHS 41-1B32	32	5.38	A	19/32	1.44	PHS 41-1A32		
35	5.86	B	5/8	2 3/8	3 3/4	1	3.12	PHS 41-1B35	35	5.86	A	19/32	1.70	PHS 41-1A35		
36	6.02	B	5/8	2 3/8	3 3/4	1	3.32	PHS 41-1B36	36	6.02	A	19/32	1.84	PHS 41-1A36		
40	6.65	B	3/4	2 3/8	3 3/4	1 1/16	4.06	PHS 41-1B40	40	6.65	A	23/32	2.22	PHS 41-1A40		
42	6.97	B	3/4	2 3/8	3 1/2	1 1/16	4.10	PHS 41-1B42	42	6.97	A	23/32	2.50	PHS 41-1A42		
45	7.45	B	3/4	2 3/8	3 1/2	1 3/16	4.18	PHS 41-1B45	45	7.45	A	23/32	2.52	PHS 41-1A45		
48	7.93	B	3/4	2 3/8	3 1/2	1 1/16	4.92	PHS 41-1B48	48	7.93	A	23/32	2.92	PHS 41-1A48		
54	8.88	B	3/4	2 3/8	3 1/2	1 1/16	5.68	PHS 41-1B54	54	8.88	A	23/32	3.54	PHS 41-1A54		
60	9.84	B	3/4	2 3/8	3 1/2	1 1/16	6.78	PHS 41-1B60	60	9.84	A	23/32	4.60	PHS 41-1A60		
70	11.43	B	3/4	2 3/4	4	1 3/16	9.54	PHS 41-1B70	70	11.43	A	23/32	6.22	PHS 41-1A70		
72	11.75	B	3/4	2 3/4	4	1 3/16	9.64	PHS 41-1B72	72	11.75	A	23/32	6.32	PHS 41-1A72		
80	13.03	B	3/4	2 3/4	4	1 3/16	11.54	PHS 41-1B80	80	13.03	A	23/32	8.46	PHS 41-1A80		
84	13.66	B	3/4	2 3/4	4	1 3/16	12.20	PHS 41-1B84	84	13.66	A	23/32	9.12	PHS 41-1A84		
96	15.57	B	1	2 3/4	4	1 3/16	14.86	PHS 41-1B96	96	15.57	A	15/16	11.84	PHS 41-1A96		
112	18.12	B	1	2 3/4	4	1 3/16	19.16	PHS 41-1B112	112	18.12	A	15/16	15.84	PHS 41-1A112		

Maximum bores can accommodate standard keyways. Larger bores are available where a shallow keyway is used or no keyway is required.

For hardened teeth sprockets, add "H" after the sprocket profile e.g. PHS 08B-1AH8.



ANSI sprockets

Simplex
Pilot Bore

- ▶ Belts
- ▶ Chains
- ▶ Couplings
- ▶ Bushings and Hubs
- ▶ Sprockets
- ▶ Pulleys
- ▶ Smart tools

ANSI 40-1 1/2" Pitch

Pilot Bore Type B

Type A

No. Teeth	Outside Diameter	Type	Bore		Hub		Weight	Designation	No. Teeth	Outside Diameter	Type	Bore Stock	Weight	Designation		
			Min	Max	H	L									Inch	lbs
			Inch	Inch	Inch	Inch									Inch	lbs
8	1.50	B	1/2	1/2	31/32	7/8	0.18	PHS 40-1B8	8	1.50	-	-	-	-	-	
9	1.67	B	1/2	9/16	1	7/8	0.20	PHS 40-1B9	9	1.67	-	-	-	-	-	
10	1.84	B	1/2	3/4	1	7/8	0.27	PHS 40-1B10	10	1.84	-	-	-	-	-	
11	2.00	B	1/2	7/8	1	7/8	0.35	PHS 40-1B11	11	2.00	-	-	-	-	-	
12	2.17	B	1/2	1	1	7/8	0.45	PHS 40-1B12	12	2.17	A	1/2	0.18	PHS 40-1A12		
13	2.33	B	1/2	1	1	7/8	0.50	PHS 40-1B13	13	2.33	A	1/2	0.22	PHS 40-1A13		
14	2.49	B	1/2	1	1	7/8	0.59	PHS 40-1B14	14	2.49	A	1/2	0.26	PHS 40-1A14		
15	2.65	B	1/2	1	1	7/8	0.70	PHS 40-1B15	15	2.65	A	5/8	0.30	PHS 40-1A15		
16	2.81	B	5/8	1	1	7/8	0.79	PHS 40-1B16	16	2.81	A	5/8	0.34	PHS 40-1A16		
17	2.98	B	5/8	1	1	7/8	1.04	PHS 40-1B17	17	2.98	A	5/8	0.36	PHS 40-1A17		
18	3.14	B	5/8	1	1	7/8	1.22	PHS 40-1B18	18	3.14	A	5/8	0.44	PHS 40-1A18		
19	3.30	B	5/8	1	1	7/8	1.43	PHS 40-1B19	19	3.30	A	5/8	0.46	PHS 40-1A19		
20	3.46	B	5/8	1	1	7/8	1.56	PHS 40-1B20	20	3.46	A	5/8	0.56	PHS 40-1A20		
21	3.62	B	5/8	1	1	7/8	1.73	PHS 40-1B21	21	3.62	A	5/8	0.58	PHS 40-1A21		
22	3.78	B	5/8	1	1	7/8	1.96	PHS 40-1B22	22	3.78	A	5/8	0.66	PHS 40-1A22		
23	3.94	B	5/8	2	3	1	2.13	PHS 40-1B23	23	3.94	A	5/8	0.72	PHS 40-1A23		
24	4.10	B	5/8	2	3	1	2.41	PHS 40-1B24	24	4.10	A	5/8	0.82	PHS 40-1A24		
25	4.26	B	5/8	2	3	1	2.54	PHS 40-1B25	25	4.26	A	5/8	0.88	PHS 40-1A25		
26	4.42	B	5/8	2	3	1	2.58	PHS 40-1B26	26	4.42	A	5/8	0.94	PHS 40-1A26		
27	4.58	B	5/8	2	3	1	2.66	PHS 40-1B27	27	4.58	A	5/8	0.98	PHS 40-1A27		
28	4.74	B	5/8	2	3	1	2.73	PHS 40-1B28	28	4.74	A	5/8	1.10	PHS 40-1A28		
29	4.90	B	5/8	2	3	1	2.80	PHS 40-1B29	29	4.90	A	19/32	1.22	PHS 40-1A29		
30	5.06	B	5/8	2	3	1	2.98	PHS 40-1B30	30	5.06	A	19/32	1.26	PHS 40-1A30		
31	5.22	B	5/8	2	3	1	3.10	PHS 40-1B31	31	5.22	A	19/32	1.40	PHS 40-1A31		
32	5.38	B	5/8	2	3	1	3.16	PHS 40-1B32	32	5.38	A	19/32	1.48	PHS 40-1A32		
33	5.54	B	5/8	2	3	1	3.22	PHS 40-1B33	33	5.54	A	19/32	1.56	PHS 40-1A33		
34	5.70	B	5/8	2	3	1	3.30	PHS 40-1B34	34	5.70	A	19/32	1.64	PHS 40-1A34		
35	5.86	B	5/8	2	3	1	3.46	PHS 40-1B35	35	5.86	A	19/32	1.70	PHS 40-1A35		
36	6.02	B	5/8	2	3	1	3.58	PHS 40-1B36	36	6.02	A	19/32	1.84	PHS 40-1A36		
37	6.18	B	5/8	2	3	1	3.62	PHS 40-1B37	37	6.18	A	19/32	1.92	PHS 40-1A37		
38	6.33	B	5/8	2	3	1	3.70	PHS 40-1B38	38	6.33	A	19/32	2.00	PHS 40-1A38		
39	6.49	B	5/8	2	3	1	3.76	PHS 40-1B39	39	6.49	A	19/32	2.02	PHS 40-1A39		
40	6.65	B	3/4	2	3	1	4.69	PHS 40-1B40	40	6.65	A	23/32	2.22	PHS 40-1A40		
41	6.81	B	3/4	2	3	1	4.76	PHS 40-1B41	41	6.81	A	23/32	2.42	PHS 40-1A41		
42	6.97	B	3/4	2	3	1	4.82	PHS 40-1B42	42	6.97	A	23/32	2.50	PHS 40-1A42		
43	7.13	B	3/4	2	3	1	5.12	PHS 40-1B43	43	7.13	A	23/32	2.80	PHS 40-1A43		
44	7.29	B	3/4	2	3	1	5.15	PHS 40-1B44	44	7.29	A	23/32	2.85	PHS 40-1A44		
45	7.45	B	3/4	2	3	1	5.30	PHS 40-1B45	45	7.45	A	23/32	3.15	PHS 40-1A45		
46	7.61	B	3/4	2	3	1	5.57	PHS 40-1B46	46	7.61	A	23/32	3.26	PHS 40-1A46		
47	7.77	B	3/4	2	3	1	5.44	PHS 40-1B47	47	7.77	A	23/32	3.32	PHS 40-1A47		
48	7.93	B	3/4	2	3	1	5.84	PHS 40-1B48	48	7.93	A	23/32	3.22	PHS 40-1A48		
49	8.09	B	3/4	2	3	1	5.90	PHS 40-1B49	49	8.09	A	23/32	3.44	PHS 40-1A49		
50	8.25	B	3/4	2	3	1	5.96	PHS 40-1B50	50	8.25	A	23/32	3.62	PHS 40-1A50		
51	8.41	B	3/4	2	3	1	6.08	PHS 40-1B51	51	8.41	A	23/32	3.94	PHS 40-1A51		
52	8.57	B	3/4	2	3	1	6.28	PHS 40-1B52	52	8.57	A	23/32	4.08	PHS 40-1A52		
53	8.73	B	3/4	2	3	1	6.33	PHS 40-1B53	53	8.73	A	23/32	4.04	PHS 40-1A53		
54	8.89	B	3/4	2	3	1	6.42	PHS 40-1B54	54	8.89	A	23/32	4.44	PHS 40-1A54		
55	9.04	B	3/4	2	3	1	6.46	PHS 40-1B55	55	9.04	A	23/32	4.54	PHS 40-1A55		
56	9.20	B	3/4	2	3	1	6.89	PHS 40-1B56	56	9.20	A	23/32	4.84	PHS 40-1A56		
57	9.36	B	3/4	2	3	1	7.02	PHS 40-1B57	57	9.36	A	23/32	5.00	PHS 40-1A57		
58	9.52	B	3/4	2	3	1	7.36	PHS 40-1B58	58	9.52	A	23/32	5.12	PHS 40-1A58		
59	9.68	B	3/4	2	3	1	7.45	PHS 40-1B59	59	9.68	A	23/32	5.30	PHS 40-1A59		
60	9.84	B	3/4	2	3	1	7.86	PHS 40-1B60	60	9.84	A	23/32	5.48	PHS 40-1A60		
70	11.43	B	3/4	2	3	1	11.00	PHS 40-1B70	70	11.43	A	23/32	7.24	PHS 40-1A70		
72	11.75	B	3/4	2	3	1	11.50	PHS 40-1B72	72	11.75	A	23/32	7.74	PHS 40-1A72		
80	13.03	B	3/4	2	3	1	13.40	PHS 40-1B80	80	13.03	A	23/32	10.20	PHS 40-1A80		
84	13.66	B	3/4	2	3	1	14.04	PHS 40-1B84	84	13.66	A	23/32	10.07	PHS 40-1A84		
96	15.57	B	1	2	3	1	17.56	PHS 40-1B96	96	15.57	A	19/16	12.15	PHS 40-1A96		
112	18.12	B	1	2	3	1	22.56	PHS 40-1B112	112	18.12	A	19/16	20.00	PHS 40-1A112		

Type A

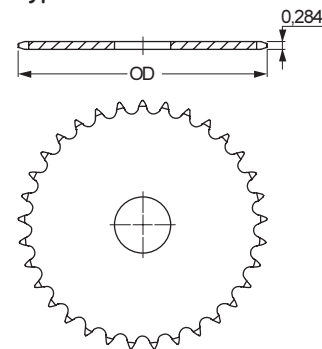

Type B

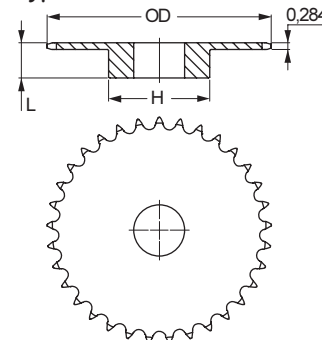

Maximum bores can accommodate standard keyways. Larger bores are available where a shallow keyway is used or no keyway is required.

For hardened teeth sprockets, add "H" after the sprocket profile e.g. PHS 08B-1AH8.



ANSI sprockets

Simplex
Pilot Bore



ANSI 50-1 5/8" Pitch

Pilot Bore Type B

Type A

No. Teeth	Outside Diameter	Type	Bore		Hub		Weight	Designation	No. Teeth	Outside Diameter	Type	Bore Stock	Weight	Designation		
			Min	Max	H	L										
			Inch	Inch	Inch	Inch										
8	1.88	B	5/8	5/8	1	1	0.25	PHS 50-1B8	8	1.88	-	-	-	-	-	
9	2.09	B	5/8	3/4	1	3/8	1	0.36	PHS 50-1B9	9	2.09	-	-	-	-	-
10	2.30	B	5/8	7/8	1	7/16	1	0.48	PHS 50-1B10	10	2.30	-	-	-	-	-
11	2.50	B	5/8	1	1	3/4	1	0.64	PHS 50-1B11	11	2.50	-	-	-	-	-
12	2.71	B	5/8	1 1/4	1	63/64	1	0.83	PHS 50-1B12	12	2.71	A	5/8	0.34	PHS 50-1A12	
13	2.91	B	5/8	1 5/16	1	7/8	1	0.88	PHS 50-1B13	13	2.91	A	5/8	0.42	PHS 50-1A13	
14	3.11	B	5/8	1 7/16	2	7/8	1	1.13	PHS 50-1B14	14	3.11	A	5/8	0.50	PHS 50-1A14	
15	3.32	B	5/8	1 1/2	2	3/8	1	1.34	PHS 50-1B15	15	3.32	A	5/8	0.54	PHS 50-1A15	
16	3.52	B	5/8	1 3/4	2	1/2	1	1.51	PHS 50-1B16	16	3.52	A	5/8	0.68	PHS 50-1A16	
17	3.72	B	5/8	1 7/8	2	11/16	1	1.74	PHS 50-1B17	17	3.72	A	5/8	0.76	PHS 50-1A17	
18	3.92	B	5/8	2	2	7/8	1	2.00	PHS 50-1B18	18	3.92	A	7/8	0.86	PHS 50-1A18	
19	4.12	B	5/8	2	3	1	1	2.22	PHS 50-1B19	19	4.12	A	5/8	0.94	PHS 50-1A19	
20	4.32	B	3/4	2	3	1	1	2.28	PHS 50-1B20	20	4.32	A	3/4	1.06	PHS 50-1A20	
21	4.52	B	3/4	2	3	1	1	2.40	PHS 50-1B21	21	4.52	A	3/4	1.12	PHS 50-1A21	
22	4.72	B	3/4	2	3	1	1	2.56	PHS 50-1B22	22	4.72	A	3/4	1.30	PHS 50-1A22	
23	4.92	B	3/4	2	3	1	1	2.66	PHS 50-1B23	23	4.92	A	3/4	1.44	PHS 50-1A23	
24	5.12	B	3/4	2	3	1	1 1/4	3.30	PHS 50-1B24	24	5.12	A	23/32	1.50	PHS 50-1A24	
25	5.32	B	3/4	2	3	1	1 1/4	3.40	PHS 50-1B25	25	5.32	A	23/32	1.62	PHS 50-1A25	
26	5.52	B	3/4	2	3	1	1 1/4	3.44	PHS 50-1B26	26	5.52	A	23/32	1.72	PHS 50-1A26	
27	5.72	B	3/4	2	3	1	1 1/4	3.74	PHS 50-1B27	27	5.72	A	23/32	1.96	PHS 50-1A27	
28	5.92	B	3/4	2	3	1	1 1/4	3.80	PHS 50-1B28	28	5.92	A	23/32	2.04	PHS 50-1A28	
29	6.12	B	3/4	2	3	1	1 1/4	4.06	PHS 50-1B29	29	6.12	A	23/32	2.36	PHS 50-1A29	
30	6.32	B	3/4	2 1/4	3	1 1/4	1 1/4	4.56	PHS 50-1B30	30	6.32	A	23/32	2.54	PHS 50-1A30	
31	6.52	B	3/4	2 1/4	3	1 1/4	1 1/4	4.74	PHS 50-1B31	31	6.52	A	23/32	2.80	PHS 50-1A31	
32	6.72	B	3/4	2 1/4	3	1 1/4	1 1/4	4.96	PHS 50-1B32	32	6.72	A	23/32	2.72	PHS 50-1A32	
33	6.92	B	3/4	2 1/4	3	1 1/4	1 1/4	5.20	PHS 50-1B33	33	6.92	A	23/32	3.14	PHS 50-1A33	
34	7.12	B	3/4	2 1/4	3	1 1/4	1 1/4	5.14	PHS 50-1B34	34	7.12	A	23/32	3.20	PHS 50-1A34	
35	7.32	B	3/4	2 1/4	3	1 1/4	1 1/4	5.44	PHS 50-1B35	35	7.32	A	23/32	3.34	PHS 50-1A35	
36	7.52	B	3/4	2 1/4	3	1 1/4	1 1/4	5.64	PHS 50-1B36	36	7.52	A	23/32	3.82	PHS 50-1A36	
37	7.72	B	3/4	2 1/4	3	1 1/4	1 1/4	5.90	PHS 50-1B37	37	7.72	A	23/32	3.98	PHS 50-1A37	
38	7.92	B	3/4	2 1/4	3	1 1/4	1 1/4	6.08	PHS 50-1B38	38	7.92	A	23/32	4.14	PHS 50-1A38	
39	8.12	B	3/4	2 1/4	3	1 1/4	1 1/4	6.30	PHS 50-1B39	39	8.12	A	23/32	4.42	PHS 50-1A39	
40	8.32	B	3/4	2 1/4	3	1 1/4	1 1/4	6.50	PHS 50-1B40	40	8.32	A	23/32	4.46	PHS 50-1A40	
41	8.52	B	3/4	2 1/4	3	1 1/4	1 1/4	6.64	PHS 50-1B41	41	8.52	A	23/32	4.86	PHS 50-1A41	
42	8.72	B	3/4	2 1/4	3	1 1/4	1 1/4	6.96	PHS 50-1B42	42	8.72	A	23/32	4.98	PHS 50-1A42	
43	8.91	B	3/4	2 1/4	3	1 1/4	1 1/4	7.06	PHS 50-1B43	43	8.91	A	23/32	5.24	PHS 50-1A43	
44	9.11	B	3/4	2 1/4	3	1 1/4	1 1/4	7.58	PHS 50-1B44	44	9.11	A	23/32	5.42	PHS 50-1A44	
45	9.31	B	3/4	2 1/2	3	1 1/4	1 1/4	8.58	PHS 50-1B45	45	9.31	A	23/32	5.92	PHS 50-1A45	
46	9.51	B	1	2 1/2	3	3/4	1 1/4	8.22	PHS 50-1B46	46	9.51	A	15/16	6.42	PHS 50-1A46	
47	9.71	B	1	2 1/2	3	3/4	1 1/4	8.48	PHS 50-1B47	47	9.71	A	15/16	6.50	PHS 50-1A47	
48	9.91	B	1	2 1/2	3	3/4	1 1/4	9.28	PHS 50-1B48	48	9.91	A	15/16	6.58	PHS 50-1A48	
49	10.11	B	1	2 1/2	3	3/4	1 1/4	9.22	PHS 50-1B49	49	10.11	A	15/16	7.06	PHS 50-1A49	
50	10.31	B	1	2 1/2	3	3/4	1 1/4	9.88	PHS 50-1B50	50	10.31	A	15/16	7.10	PHS 50-1A50	
51	10.51	B	1	2 1/2	3	3/4	1 1/4	9.70	PHS 50-1B51	51	10.51	A	15/16	7.32	PHS 50-1A51	
52	10.71	B	1	2 1/2	3	3/4	1 1/4	10.24	PHS 50-1B52	52	10.71	A	15/16	7.98	PHS 50-1A52	
53	10.91	B	1	2 1/2	3	3/4	1 1/4	10.48	PHS 50-1B53	53	10.91	A	15/16	8.08	PHS 50-1A53	
54	11.11	B	1	2 1/2	3	3/4	1 1/4	11.00	PHS 50-1B54	54	11.11	A	15/16	8.30	PHS 50-1A54	
55	11.31	B	1	2 1/2	3	3/4	1 1/4	10.93	PHS 50-1B55	55	11.31	A	15/16	8.56	PHS 50-1A55	
56	11.50	B	1	2 1/2	3	3/4	1 1/4	11.50	PHS 50-1B56	56	11.50	A	15/16	8.90	PHS 50-1A56	
57	11.70	B	1	2 1/2	3	3/4	1 1/4	12.00	PHS 50-1B57	57	11.70	A	15/16	9.38	PHS 50-1A57	
58	11.90	B	1	2 1/2	3	3/4	1 1/4	11.82	PHS 50-1B58	58	11.90	A	15/16	10.30	PHS 50-1A58	
59	12.10	B	1	2 1/2	3	3/4	1 1/4	12.32	PHS 50-1B59	59	12.10	A	15/16	10.50	PHS 50-1A59	
60	12.30	B	1	2 1/2	3	3/4	1 1/4	13.00	PHS 50-1B60	60	12.30	A	15/16	10.80	PHS 50-1A60	
70	14.29	B	1	2 1/2	3	3/4	1 3/4	18.16	PHS 50-1B70	70	14.29	A	15/16	14.00	PHS 50-1A70	
72	14.69	B	1	2 1/2	3	3/4	1 3/4	19.48	PHS 50-1B72	72	14.69	A	15/16	15.24	PHS 50-1A72	
76	15.49	B	1	2 3/4	3	3/4	1 3/4	21.00	PHS 50-1B76	76	15.49	A	15/16	20.08	PHS 50-1A76	
80	16.28	B	1	2 3/4	4	1/4	1 3/4	24.74	PHS 50-1B80	80	16.28	A	15/16	21.00	PHS 50-1A80	
84	17.08	B	1	2 3/4	4	1/4	1 3/4	25.50	PHS 50-1B84	84	17.08	A	15/16	22.08	PHS 50-1A84	
95	19.27	B	1	2 3/4	4	1/4	1 3/4	32.00	PHS 50-1B95	95	19.27	A	15/16	27.00	PHS 50-1A95	
96	19.47	B	1	2 3/4	4	1/4	1 3/4	32.92	PHS 50-1B96	96	19.47	A	15/16	27.40	PHS 50-1A96	
112	22.65	B	1	2 3/4	4	1/4	1 3/4	42.00	PHS 50-1B112	112	22.65	A	15/16	37.70	PHS 50-1A112	

Type A

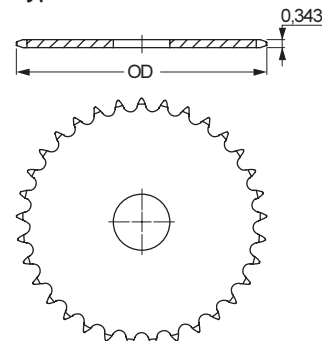

Type B

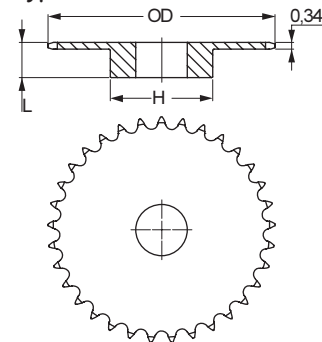

Maximum bores can accommodate standard keyways. Larger bores are available where a shallow keyway is used or no keyway is required.

For hardened teeth sprockets, add "H" after the sprocket profile e.g. PHS 08B-1AH8.



ANSI sprockets

Simplex
Pilot Bore

- ▶ Belts
- ▶ Chains
- ▶ Couplings
- ▶ Bushings and Hubs
- ▶ Sprockets
- ▶ Pulleys
- ▶ Smart tools

ANSI 60-1 3/4" Pitch

Pilot Bore Type B

Type A

No. Teeth	Outside Diameter	Type	Bore		Hub		Weight	Designation	No. Teeth	Outside Diameter	Type	Bore Stock	Weight	Designation
			Min	Max	H	L								
	Inch		Inch	Inch	Inch	Inch			Inch		Inch	lbs		
8	2.26	B	5/8	5/8	1 15/32	1 1/4	0.54	PHS 60-1B88	8	2.26	-	-	-	-
9	2.51	B	3/4	7/8	1 1/16	1 3/4	0.64	PHS 60-1B9	9	2.51	-	-	-	-
10	2.76	B	3/4	1 1/8	1 15/16	1 3/4	0.99	PHS 60-1B10	10	2.76	A	3/4	0.44	PHS 60-1A10
11	3.00	B	3/4	1 5/16	2 3/16	1 3/4	1.16	PHS 60-1B11	11	3.00	A	3/4	0.54	PHS 60-1A11
12	3.25	B	3/4	1 3/8	2 3/8	1 3/4	1.47	PHS 60-1B12	12	3.25	A	3/4	0.68	PHS 60-1A12
13	3.49	B	3/4	1 1/2	2 11/32	1 3/4	1.66	PHS 60-1B13	13	3.49	A	3/4	0.80	PHS 60-1A13
14	3.74	B	3/4	1 3/4	2 7/16	1 3/4	2.00	PHS 60-1B14	14	3.74	A	3/4	0.94	PHS 60-1A14
15	3.98	B	3/4	1 7/8	2 1/8	1 3/4	2.51	PHS 60-1B15	15	3.98	A	3/4	1.08	PHS 60-1A15
16	4.22	B	3/4	2	3 1/16	1 3/4	2.81	PHS 60-1B16	16	4.22	A	3/4	1.24	PHS 60-1A16
17	4.46	B	3/4	2 1/4	3 3/16	1 3/4	3.22	PHS 60-1B17	17	4.46	A	3/4	1.44	PHS 60-1A17
18	4.70	B	3/4	2 3/8	3 1/2	1 3/4	3.72	PHS 60-1B18	18	4.70	A	3/4	1.62	PHS 60-1A18
19	4.95	B	3/4	2 3/8	3 1/2	1 3/4	3.92	PHS 60-1B19	19	4.95	A	3/4	1.84	PHS 60-1A19
20	5.19	B	3/4	2 5/8	3 7/8	1 3/4	4.63	PHS 60-1B20	20	5.19	A	3/4	2.12	PHS 60-1A20
21	5.43	B	3/4	2 3/4	4	1 3/4	5.00	PHS 60-1B21	21	5.43	A	3/4	2.28	PHS 60-1A21
22	5.67	B	3/4	2 3/4	4	1 3/4	5.25	PHS 60-1B22	22	5.67	A	3/4	2.48	PHS 60-1A22
23	5.91	B	3/4	2 3/4	4	1 3/4	5.48	PHS 60-1B23	23	5.91	A	3/4	2.68	PHS 60-1A23
24	6.15	B	3/4	2 3/4	4	1 3/4	5.78	PHS 60-1B24	24	6.15	A	23/32	3.00	PHS 60-1A24
25	6.39	B	3/4	2 3/4	4	1 3/4	6.13	PHS 60-1B25	25	6.39	A	23/32	3.34	PHS 60-1A25
26	6.63	B	3/4	2 3/4	4	1 3/4	6.38	PHS 60-1B26	26	6.63	A	23/32	3.54	PHS 60-1A26
27	6.87	B	3/4	2 3/4	4	1 3/4	6.72	PHS 60-1B27	27	6.87	A	23/32	3.96	PHS 60-1A27
28	7.11	B	3/4	2 3/4	4	1 3/4	6.88	PHS 60-1B28	28	7.11	A	23/32	4.14	PHS 60-1A28
29	7.35	B	3/4	2 3/4	4	1 3/4	7.28	PHS 60-1B29	29	7.35	A	23/32	4.40	PHS 60-1A29
30	7.59	B	3/4	2 3/4	4	1 3/4	7.58	PHS 60-1B30	30	7.59	A	23/32	4.78	PHS 60-1A30
31	7.83	B	3/4	2 3/4	4	1 3/4	7.72	PHS 60-1B31	31	7.83	A	23/32	5.24	PHS 60-1A31
32	8.07	B	3/4	2 3/4	4	1 3/4	8.26	PHS 60-1B32	32	8.07	A	23/32	5.52	PHS 60-1A32
33	8.30	B	1	2 3/4	4	1 3/4	8.42	PHS 60-1B33	33	8.30	A	15/16	5.86	PHS 60-1A33
34	8.54	B	1	2 3/4	4	1 3/4	8.80	PHS 60-1B34	34	8.54	A	15/16	6.16	PHS 60-1A34
35	8.78	B	1	2 3/4	4	1 3/4	9.04	PHS 60-1B35	35	8.78	A	15/16	6.78	PHS 60-1A35
36	9.02	B	1	2 3/4	4	1 3/4	9.60	PHS 60-1B36	36	9.02	A	15/16	6.82	PHS 60-1A36
37	9.26	B	1	2 3/4	4	1 3/4	10.24	PHS 60-1B37	37	9.26	A	15/16	7.52	PHS 60-1A37
38	9.50	B	1	2 3/4	4 3/4	1 3/4	10.84	PHS 60-1B38	38	9.50	A	15/16	7.84	PHS 60-1A38
39	9.74	B	1	2 3/4	4 3/4	1 3/4	11.36	PHS 60-1B39	39	9.74	A	15/16	8.28	PHS 60-1A39
40	9.98	B	1	2 3/4	4 3/4	1 3/4	11.50	PHS 60-1B40	40	9.98	A	15/16	8.56	PHS 60-1A40
41	10.22	B	1	2 3/4	4 3/4	1 3/4	12.14	PHS 60-1B41	41	10.22	A	15/16	9.10	PHS 60-1A41
42	10.46	B	1	2 3/4	4 3/4	1 3/4	12.74	PHS 60-1B42	42	10.46	A	15/16	9.84	PHS 60-1A42
43	10.70	B	1	2 3/4	4 3/4	1 3/4	13.00	PHS 60-1B43	43	10.70	A	15/16	9.74	PHS 60-1A43
44	10.94	B	15/16	2 3/4	4 3/4	1 3/4	13.88	PHS 60-1B44	44	10.94	A	15/16	10.76	PHS 60-1A44
45	11.18	B	15/16	2 3/4	4 3/4	1 3/4	13.98	PHS 60-1B45	45	11.18	A	15/16	11.08	PHS 60-1A45
46	11.42	B	15/16	2 3/4	4 3/4	1 3/4	14.60	PHS 60-1B46	46	11.42	A	15/16	11.50	PHS 60-1A46
47	11.65	B	15/16	2 3/4	4 3/4	1 3/4	15.00	PHS 60-1B47	47	11.65	A	15/16	12.32	PHS 60-1A47
48	11.89	B	15/16	2 3/4	4 3/4	1 3/4	15.82	PHS 60-1B48	48	11.89	A	15/16	12.42	PHS 60-1A48
49	12.13	B	15/16	2 3/4	4 3/4	1 3/4	15.90	PHS 60-1B49	49	12.13	A	15/16	12.92	PHS 60-1A49
50	12.37	B	15/16	2 3/4	4 3/4	1 3/4	17.66	PHS 60-1B50	50	12.37	A	15/16	13.98	PHS 60-1A50
51	12.61	B	15/16	2 3/4	4 3/4	1 3/4	16.98	PHS 60-1B51	51	12.61	A	15/16	14.58	PHS 60-1A51
52	12.85	B	15/16	2 3/4	4 3/4	1 3/4	17.93	PHS 60-1B52	52	12.85	A	15/16	14.60	PHS 60-1A52
53	13.09	B	15/16	2 3/4	4 3/4	1 3/4	17.99	PHS 60-1B53	53	13.09	A	15/16	15.84	PHS 60-1A53
54	13.33	B	15/16	2 3/4	4 3/4	1 3/4	21.60	PHS 60-1B54	54	13.33	A	15/16	15.92	PHS 60-1A54
55	13.57	B	1 1/4	2 3/4	4 3/4	1 3/4	21.14	PHS 60-1B55	55	13.57	A	1 1/4	16.96	PHS 60-1A55
56	13.81	B	1 1/4	2 3/4	4 3/4	1 3/4	21.88	PHS 60-1B56	56	13.81	A	1 1/4	17.60	PHS 60-1A56
57	14.04	B	1 1/4	2 3/4	4 3/4	1 3/4	22.26	PHS 60-1B57	57	14.04	A	1 1/4	17.62	PHS 60-1A57
58	14.28	B	1 1/4	2 3/4	4 3/4	1 3/4	22.80	PHS 60-1B58	58	14.28	A	1 1/4	19.00	PHS 60-1A58
59	14.52	B	1 1/4	2 3/4	4 3/4	1 3/4	23.86	PHS 60-1B59	59	14.52	A	1 1/4	19.20	PHS 60-1A59
60	14.76	B	1 1/4	2 3/4	4 3/4	1 3/4	25.22	PHS 60-1B60	60	14.76	A	1 1/4	20.02	PHS 60-1A60
64	15.72	B	1 3/4	2 3/4	4 3/4	1 3/4	27.40	PHS 60-1B64	64	15.72	A	1 3/4	23.00	PHS 60-1A64
65	15.96	B	1 3/4	2 3/4	4 3/4	1 3/4	28.92	PHS 60-1B65	65	15.96	A	1 3/4	23.24	PHS 60-1A65
66	-	-	-	-	-	-	-	-	66	-	A	1 3/4	24.42	PHS 60-1A66
68	16.67	B	1 3/4	2 3/4	4 3/4	1 3/4	30.38	PHS 60-1B68	68	16.67	A	1 3/4	25.54	PHS 60-1A68
70	17.15	B	1 3/4	2 3/4	4 3/4	1 3/4	31.98	PHS 60-1B70	70	17.15	A	1 3/4	27.20	PHS 60-1A70
72	17.63	B	1 3/4	2 3/4	4 3/4	2	34.18	PHS 60-1B72	72	17.63	A	1 3/4	28.90	PHS 60-1A72
76	18.58	B	1 3/4	2 3/4	4 3/4	2	38.06	PHS 60-1B76	76	18.58	A	1 3/4	32.34	PHS 60-1A76
80	19.54	B	1 3/4	2 3/4	4 3/4	2	41.88	PHS 60-1B80	80	19.54	A	1 3/4	45.50	PHS 60-1A80
84	20.49	B	1 3/4	3 1/4	4 3/4	2	46.46	PHS 60-1B84	84	20.49	A	1 3/4	40.18	PHS 60-1A84
90	21.93	B	1 3/4	3 5/16	5	2 1/4	63.20	PHS 60-1B90	90	21.93	A	1 3/4	43.44	PHS 60-1A90
96	23.36	B	1 3/4	3 3/4	5 1/2	2 1/4	63.08	PHS 60-1B96	96	23.36	A	1 3/4	52.02	PHS 60-1A96

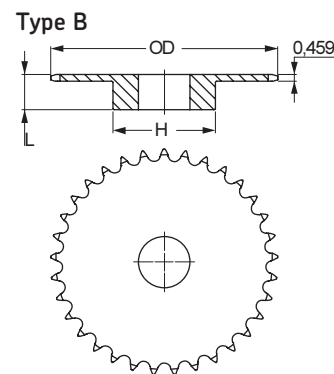
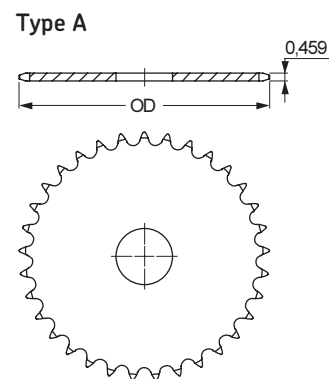

Maximum bores can accommodate standard keyways. Larger bores are available where a shallow keyway is used or no keyway is required. For hardened teeth sprockets, add "H" after the sprocket profile e.g. PHS 08B-1AH8.

ANSI sprockets

Simplex
Pilot Bore



ANSI 80-1 1" Pitch

Pilot Bore Type B/C

Type A

No. Teeth	Outside Diameter	Type	Bore		Hub		Weight	Designation	No. Teeth	Outside Diameter	Type	Bore Stock	Weight	Designation	
			Min	Max	H	L									
			Inch	Inch	Inch	Inch									lbs
8	3.01	B	1	1	1 15/16	1 5/8	1.40	PHS 80-1B8	8	3.01	-	-	-	-	
9	3.35	B	1	1 5/16	2 1/4	1 5/8	1.60	PHS 80-1B9	9	3.35	A	15/16	0.80	PHS 80-1A9	
10	3.68	B	1	1 1/2	2 9/16	1 5/8	2.20	PHS 80-1B10	10	3.68	A	15/16	1.00	PHS 80-1A10	
11	4.01	B	1	1 5/8	2 13/16	1 5/8	3.20	PHS 80-1B11	11	4.01	A	15/16	1.30	PHS 80-1A11	
12	4.33	B	1	1 7/8	3 1/8	1 5/8	3.40	PHS 80-1B12	12	4.33	A	15/16	1.50	PHS 80-1A12	
13	4.66	B	1	2	3	1 1/2	3.50	PHS 80-1B13	13	4.66	A	15/16	1.80	PHS 80-1A13	
14	4.98	B	1	2 1/4	3 1/4	1 1/2	4.10	PHS 80-1B14	14	4.98	A	15/16	2.20	PHS 80-1A14	
15	5.30	B	1	2 1/2	3 13/16	1 1/2	5.30	PHS 80-1B15	15	5.30	A	15/16	2.50	PHS 80-1A15	
16	5.63	B	1	2 3/4	4	1 1/2	5.90	PHS 80-1B16	16	5.63	A	15/16	2.90	PHS 80-1A16	
17	5.95	B	1	2 3/4	4	1 1/2	6.60	PHS 80-1B17	17	5.95	A	15/16	3.30	PHS 80-1A17	
18	6.27	B	1	2 3/4	4 1/4	1 1/2	7.30	PHS 80-1B18	18	6.27	A	15/16	3.70	PHS 80-1A18	
19	6.59	B	1	2 3/4	4 1/4	1 1/2	7.80	PHS 80-1B19	19	6.59	A	15/16	4.10	PHS 80-1A19	
20	6.91	B	1	2 3/4	4 1/4	1 1/2	8.40	PHS 80-1B20	20	6.91	A	15/16	4.70	PHS 80-1A20	
21	7.24	B	1	2 3/4	4 1/4	1 1/2	9.40	PHS 80-1B21	21	7.24	A	15/16	4.90	PHS 80-1A21	
22	7.56	B	1	2 3/4	4 1/4	1 3/4	10.00	PHS 80-1B22	22	7.56	A	15/16	5.50	PHS 80-1A22	
23	7.88	B	1	2 3/4	4 1/4	1 3/4	10.70	PHS 80-1B23	23	7.88	A	15/16	6.30	PHS 80-1A23	
24	8.20	B	1	2 3/4	4 1/4	1 3/4	11.30	PHS 80-1B24	24	8.20	A	15/16	6.70	PHS 80-1A24	
25	8.52	B	1	2 3/4	4 1/4	1 3/4	11.90	PHS 80-1B25	25	8.52	A	15/16	7.20	PHS 80-1A25	
26	8.84	B	1	2 3/4	4 1/4	2	14.30	PHS 80-1B26	26	8.84	A	1 3/16	7.80	PHS 80-1A26	
27	9.16	B	1	2 3/4	4 3/4	2	15.40	PHS 80-1B27	27	9.16	A	1 3/16	8.60	PHS 80-1A27	
28	9.48	B	1	2 3/4	4 3/4	2	16.00	PHS 80-1B28	28	9.48	A	1 3/16	9.30	PHS 80-1A28	
29	9.80	B	1	2 3/4	4 3/4	2	17.10	PHS 80-1B29	29	9.80	A	1 3/16	9.80	PHS 80-1A29	
30	10.11	B	1	2 3/4	4 3/4	2	17.40	PHS 80-1B30	30	10.11	A	1 3/16	10.70	PHS 80-1A30	
31	10.43	B	1	2 3/4	4 3/4	2	18.70	PHS 80-1B31	31	10.43	A	1 3/16	11.30	PHS 80-1A31	
32	10.75	B	1	2 3/4	4 3/4	2	19.50	PHS 80-1B32	32	10.75	A	1 3/16	12.10	PHS 80-1A32	
33	11.07	B	1	2 3/4	4 3/4	2	19.60	PHS 80-1B33	33	11.07	A	1 3/16	13.60	PHS 80-1A33	
34	11.39	B	1	2 3/4	4 3/4	2	21.30	PHS 80-1B34	34	11.39	A	1 3/16	14.30	PHS 80-1A34	
35	11.71	B	1	2 3/4	4 3/4	2	22.10	PHS 80-1B35	35	11.71	A	1 3/16	14.80	PHS 80-1A35	
36	12.03	B	1	2 3/4	4 3/4	2	23.10	PHS 80-1B36	36	12.03	A	1 3/16	16.10	PHS 80-1A36	
37	12.35	B	1	2 3/4	4 3/4	2	23.80	PHS 80-1B37	37	12.35	A	1 3/16	16.80	PHS 80-1A37	
38	12.67	B	1	2 3/4	4 3/4	2	24.70	PHS 80-1B38	38	12.67	A	1 3/16	17.20	PHS 80-1A38	
39	12.99	B	1	2 3/4	4 3/4	2	25.60	PHS 80-1B39	39	12.99	A	1 3/16	17.90	PHS 80-1A39	
40	13.31	B	1	2 3/4	4 3/4	2	26.70	PHS 80-1B40	40	13.31	A	1 3/16	18.90	PHS 80-1A40	
41	13.63	B	1	2 3/4	4 3/4	2	27.80	PHS 80-1B41	41	13.63	A	1 3/16	21.00	PHS 80-1A41	
42	13.94	B	1	2 3/4	4 3/4	2	28.70	PHS 80-1B42	42	13.94	A	1 3/4	21.80	PHS 80-1A42	
43	14.26	B	1	2 3/4	4 3/4	2	29.40	PHS 80-1B43	43	14.26	A	1 3/4	23.60	PHS 80-1A43	
44	14.58	B	1	2 3/4	4 3/4	2	29.90	PHS 80-1B44	44	14.58	A	1 3/4	24.30	PHS 80-1A44	
45	14.90	B	1	2 3/4	4 3/4	2	31.40	PHS 80-1B45	45	14.90	A	1 3/4	25.20	PHS 80-1A45	
46	15.22	B	1	2 3/4	4 3/4	2	33.10	PHS 80-1B46	46	15.22	A	1 3/4	26.60	PHS 80-1A46	
47	15.54	B	1	2 3/4	4 3/4	2	34.00	PHS 80-1B47	47	15.54	A	1 3/4	26.40	PHS 80-1A47	
48	15.86	B	1	2 3/4	4 3/4	2	35.50	PHS 80-1B48	48	15.86	A	1 3/4	27.80	PHS 80-1A48	
49	16.18	B	1	2 3/4	4 3/4	2	35.80	PHS 80-1B49	49	16.18	A	1 3/4	28.90	PHS 80-1A49	
50	16.50	B	1	2 3/4	4 3/4	2	37.30	PHS 80-1B50	50	16.50	A	1 3/4	30.90	PHS 80-1A50	
51	16.81	B	1	2 3/4	4 3/4	2	38.60	PHS 80-1B51	51	16.81	A	1 3/4	32.20	PHS 80-1A51	
52	17.13	B	1	2 3/4	4 3/4	2	39.40	PHS 80-1B52	52	17.13	A	1 3/4	33.00	PHS 80-1A52	
53	17.45	B	1	2 3/4	4 3/4	2	41.30	PHS 80-1B53	53	17.45	A	1 3/4	34.90	PHS 80-1A53	
54	17.77	B	1	2 3/4	5 1/4	2	44.70	PHS 80-1B54	54	17.77	A	1 3/4	36.60	PHS 80-1A54	
55	18.09	B	1	2 3/4	5 1/4	2	45.60	PHS 80-1B55	55	18.09	A	1 3/4	37.50	PHS 80-1A55	
56	18.41	B	1	2 3/4	5 1/4	2	47.50	PHS 80-1B56	56	18.41	A	1 3/4	39.40	PHS 80-1A56	
57	18.73	B	1	2 3/4	5 1/4	2	48.50	PHS 80-1B57	57	18.73	A	1 3/4	40.40	PHS 80-1A57	
58	19.04	B	1	2 3/4	5 1/4	2	50.50	PHS 80-1B58	58	19.04	A	1 3/4	41.30	PHS 80-1A58	
59	19.36	B	1	2 3/4	5 1/4	2	52.10	PHS 80-1B59	59	19.36	A	1 3/4	42.90	PHS 80-1A59	
60	19.68	B	1	2 3/4	5 1/4	2	54.50	PHS 80-1B60	60	19.68	A	1 3/4	45.30	PHS 80-1A60	
65	21.27	B	1	2 3/4	5 3/4	2	61.80	PHS 80-1B65	65	21.27	A	1 3/4	52.20	PHS 80-1A65	
70	22.87	C	1	1/2	4 1/4	6 1/4	3 1/2	75.70	PHS 80-1C70	70	22.87	A	1 1/2	59.80	PHS 80-1A70
72	23.50	C	1	1/2	4 3/4	6 3/4	3 1/2	81.40	PHS 80-1C72	72	23.50	A	1 1/2	65.70	PHS 80-1A72
76	24.78	C	1	1/2	4 1/4	6 3/4	3 1/2	87.80	PHS 80-1C76	76	24.78	A	1 1/2	70.20	PHS 80-1A76
80	26.05	C	1	1/2	4 1/4	6 3/4	3 1/2	89.90	PHS 80-1C80	80	26.05	A	1 1/2	79.60	PHS 80-1A80
84	27.33	C	1	1/2	4 1/4	6 3/4	3 1/2	99.20	PHS 80-1C84	84	27.33	A	1 1/2	86.10	PHS 80-1A84
90	29.24	C	1	1/2	4 1/4	6 3/4	3 1/2	106.00	PHS 80-1C90	90	29.24	A	1 1/2	101.00	PHS 80-1A90
96	31.15	C	1	1/2	4 1/4	6 3/4	3 1/2	117.00	PHS 80-1C96	96	31.15	A	1 1/2	120.00	PHS 80-1A96
112	36.24	C	1	1/2	4 1/4	6 3/4	3 1/2	154.00	PHS 80-1C112	112	36.24	A	1 1/2	165.00	PHS 80-1A112

Type A

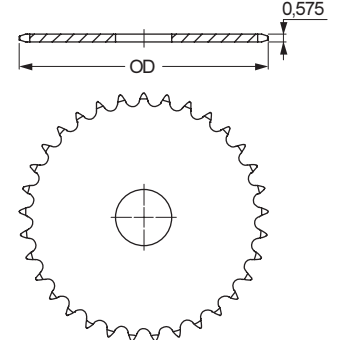

Type B

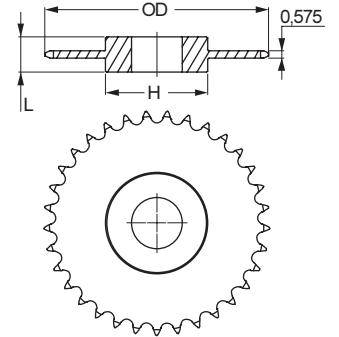

Type C

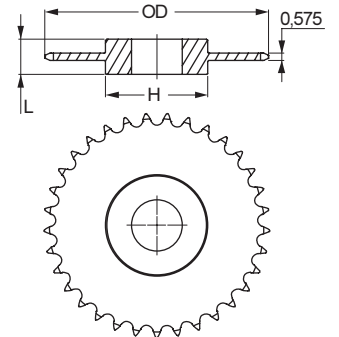

Maximum bores can accommodate standard keyways. Larger bores are available where a shallow keyway is used or no keyway is required.

For hardened teeth sprockets, add "H" after the sprocket profile e.g. PHS 08B-1AH8.



ANSI sprockets

Simplex

Pilot Bore

- ▶ Belts
- ▶ Chains
- ▶ Couplings
- ▶ Bushings and Hubs
- ▶ Sprockets
- ▶ Pulleys
- ▶ Smart tools

ANSI 100-1 1 1/4" Pitch

Pilot Bore Type B/C

Type A

No. Teeth	Outside Diameter	Type	Bore		Hub		Weight	Designation	No. Teeth	Outside Diameter	Type	Bore Stock	Weight	Designation
			Min	Max	H	L								
	Inch		Inch	Inch	Inch	Inch	lbs				Inch	lbs		
7	3,35	-	-	-	-	-	-	-	7	3,35	A	1	1,20	PHS 100-1A7
8	3,77	B	1	1 1/4	2 7/16	1 7/8	2,30	PHS 100-1B8	8	3,77	A	1	1,40	PHS 100-1A8
9	4,18	B	1	1 1/8	2 13/16	1 7/8	3,20	PHS 100-1B9	9	4,18	A	1	1,60	PHS 100-1A9
10	4,60	B	1	1 7/8	3 1/4	1 7/8	4,10	PHS 100-1B10	10	4,60	A	1	2,00	PHS 100-1A10
11	5,01	B	1	2 1/4	3 9/16	1 7/8	5,30	PHS 100-1B11	11	5,01	A	1 1/4	2,50	PHS 100-1A11
12	5,42	B	1	2 3/4	4	1 7/8	6,40	PHS 100-1B12	12	5,42	A	1 3/4	3,00	PHS 100-1A12
13	5,82	B	1	2 3/8	3 7/8	1 5/8	6,60	PHS 100-1B13	13	5,82	A	1 1/4	3,50	PHS 100-1A13
14	6,23	B	1 1/4	2 3/4	4 3/16	1 5/8	7,40	PHS 100-1B14	14	6,23	A	1 3/4	4,10	PHS 100-1A14
15	6,63	B	1 1/4	3	4 1/2	1 3/4	9,20	PHS 100-1B15	15	6,63	A	1 1/4	4,70	PHS 100-1A15
16	7,03	B	1 5/16	3	4 1/2	1 3/4	9,90	PHS 100-1B16	16	7,03	A	1 3/4	5,40	PHS 100-1A16
17	7,44	B	1 5/16	3	4 1/2	1 3/4	10,80	PHS 100-1B17	17	7,44	A	1 3/4	6,10	PHS 100-1A17
18	7,84	B	1 5/16	3	4 1/2	1 3/4	11,50	PHS 100-1B18	18	7,84	A	1 3/4	7,00	PHS 100-1A18
19	8,24	B	1 5/16	3	4 1/2	2	13,10	PHS 100-1B19	19	8,24	A	1 3/4	7,80	PHS 100-1A19
20	8,64	B	1 5/16	3	4 1/2	2	14,20	PHS 100-1B20	20	8,64	A	1 3/4	8,80	PHS 100-1A20
21	9,04	B	1 5/16	3	4 1/2	2	15,30	PHS 100-1B21	21	9,04	A	1 3/4	9,80	PHS 100-1A21
22	9,44	B	1 5/16	3	4 1/2	2	16,10	PHS 100-1B22	22	9,44	A	1 3/4	10,50	PHS 100-1A22
23	9,84	B	1 1/4	3	4 1/2	2	17,20	PHS 100-1B23	23	9,84	A	1 3/4	11,80	PHS 100-1A23
24	10,25	B	1 1/4	3	4 1/2	2	19,20	PHS 100-1B24	24	10,25	A	1 3/4	12,80	PHS 100-1A24
25	10,65	B	1 1/4	3	4 1/2	2	19,50	PHS 100-1B25	25	10,65	A	1 3/4	13,90	PHS 100-1A25
26	11,05	B	1 3/4	3 5/16	5	2	21,70	PHS 100-1B26	26	11,05	A	1 3/4	15,00	PHS 100-1A26
27	11,44	B	1 3/4	3 5/16	5	2	23,00	PHS 100-1B27	27	11,44	A	1 3/4	16,00	PHS 100-1A27
28	11,84	B	1 3/4	3 5/16	5	2	24,40	PHS 100-1B28	28	11,84	A	1 3/4	17,40	PHS 100-1A28
29	12,24	B	1 3/4	3 5/16	5	2	25,00	PHS 100-1B29	29	12,24	A	1 3/4	19,60	PHS 100-1A29
30	12,64	B	1 3/4	3 5/16	5	2	26,90	PHS 100-1B30	30	12,64	A	1 3/4	20,10	PHS 100-1A30
31	13,04	-	-	-	-	-	-	-	31	13,04	A	1 3/4	21,50	PHS 100-1A31
32	13,44	B	1 3/4	3 5/16	5	2	29,80	PHS 100-1B32	32	13,44	A	1 3/4	22,60	PHS 100-1A32
33	13,84	-	-	-	-	-	-	-	33	13,84	A	1 3/4	24,10	PHS 100-1A33
34	14,24	-	-	-	-	-	-	-	34	14,24	A	1 3/4	26,00	PHS 100-1A34
35	14,64	B	1 3/4	3 5/16	5	2 1/2	36,90	PHS 100-1B35	35	14,64	A	1 3/4	27,20	PHS 100-1A35
36	15,04	B	1 3/4	3 5/16	5	2 1/2	38,60	PHS 100-1B36	36	15,04	A	1 3/4	30,00	PHS 100-1A36
37	15,44	-	-	-	-	-	-	-	37	15,44	A	1 3/4	31,00	PHS 100-1A37
38	15,84	B	1 3/4	3 5/16	5	2 1/2	41,50	PHS 100-1B38	38	15,84	A	1 3/4	33,00	PHS 100-1A38
39	16,23	B	1 3/4	3 5/16	5	2 1/2	43,60	PHS 100-1B39	39	16,23	A	1 3/4	35,00	PHS 100-1A39
40	16,63	B	1 3/4	3 5/16	5	2 1/2	46,90	PHS 100-1B40	40	16,63	A	1 3/4	36,00	PHS 100-1A40
41	17,03	-	-	-	-	-	-	-	41	17,03	A	1 3/4	39,00	PHS 100-1A41
42	17,43	B	1 3/4	3 5/16	5	2 1/2	50,40	PHS 100-1B42	42	17,43	A	1 3/4	40,00	PHS 100-1A42
43	17,83	-	-	-	-	-	-	-	43	17,83	A	1 1/2	43,00	PHS 100-1A43
44	18,23	-	-	-	-	-	-	-	44	18,23	A	1 1/2	45,00	PHS 100-1A44
45	18,63	B	1 1/2	3 5/16	5	2 1/2	54,00	PHS 100-1B45	45	18,63	A	1 1/2	47,00	PHS 100-1A45
46	19,02	-	-	-	-	-	-	-	46	19,02	A	1 1/2	48,00	PHS 100-1A46
47	19,42	-	-	-	-	-	-	-	47	19,42	A	1 1/2	52,00	PHS 100-1A47
48	19,82	B	1 1/2	4	6	2 1/2	66,00	PHS 100-1B48	48	19,82	A	1 1/2	54,00	PHS 100-1A48
49	20,22	-	-	-	-	-	-	-	49	20,22	A	1 1/2	56,00	PHS 100-1A49
50	20,62	-	-	-	-	-	-	-	50	20,62	A	1 1/2	57,00	PHS 100-1A50
51	21,02	-	-	-	-	-	-	-	51	21,02	A	1 1/2	63,00	PHS 100-1A51
52	21,42	-	-	-	-	-	-	-	52	21,42	A	1 1/2	64,00	PHS 100-1A52
53	21,81	-	-	-	-	-	-	-	53	21,81	A	1 1/2	64,20	PHS 100-1A53
54	22,21	C	1 1/2	4	6	3 1/4	78,00	PHS 100-1C54	54	22,21	A	1 1/2	68,00	PHS 100-1A54
55	22,61	-	-	-	-	-	-	-	55	22,61	A	1 1/2	70,00	PHS 100-1A55
56	23,01	-	-	-	-	-	-	-	56	23,01	A	1 1/2	72,00	PHS 100-1A56
57	23,41	-	-	-	-	-	-	-	57	23,41	A	1 1/2	75,80	PHS 100-1A57
58	23,81	-	-	-	-	-	-	-	58	23,81	A	1 1/2	76,00	PHS 100-1A58
59	24,20	-	-	-	-	-	-	-	59	24,20	A	1 1/2	77,00	PHS 100-1A59
60	24,60	C	1 1/2	4	6	3 1/4	89,00	PHS 100-1C60	60	24,60	A	1 1/2	80,00	PHS 100-1A60
70	28,58	C	1 1/2	5 1/4	7	3 3/4	125,00	PHS 100-1C70	70	28,58	A	1 1/2	113,00	PHS 100-1A70
72	29,38	C	1 1/2	5 1/4	7	3 3/4	134,00	PHS 100-1C72	72	29,38	A	1 1/2	119,00	PHS 100-1A72
76	30,97	C	1 1/2	5 1/4	7	3 3/4	143,00	PHS 100-1C76	76	30,97	A	1 1/2	133,00	PHS 100-1A76
80	32,57	C	1 1/2	5 1/4	7	3 3/4	151,00	PHS 100-1C80	80	32,57	A	1 1/2	146,00	PHS 100-1A80
84	34,16	C	1 1/2	5 1/4	7	3 3/4	170,00	PHS 100-1C84	84	34,16	A	1 1/2	162,00	PHS 100-1A84
90	36,55	C	1 1/2	5 1/4	7	3 3/4	184,00	PHS 100-1C90	90	36,55	A	1 1/2	193,00	PHS 100-1A90
96	38,93	C	1 1/2	5 1/4	7	4 1/2	203,00	PHS 100-1C96	96	38,93	A	1 1/2	215,00	PHS 100-1A96

Type A

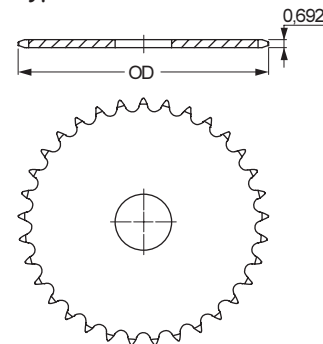

Type B

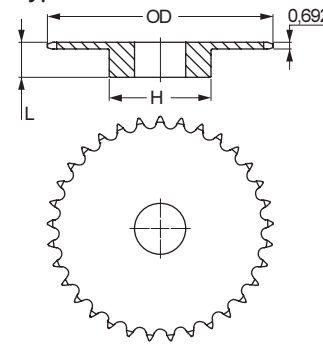

Type C

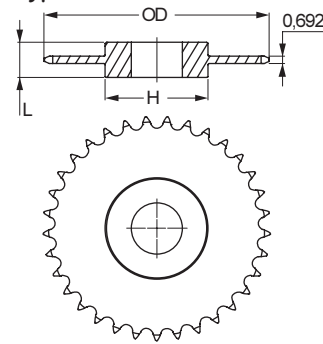

Maximum bores can accommodate standard keyways. Larger bores are available where a shallow keyway is used or no keyway is required.

For hardened teeth sprockets, add "H" after the sprocket profile e.g. PHS 08B-1AH8.

ANSI sprockets

Simplex
Pilot Bore



ANSI 120-1 1 1/2" Pitch

Type A

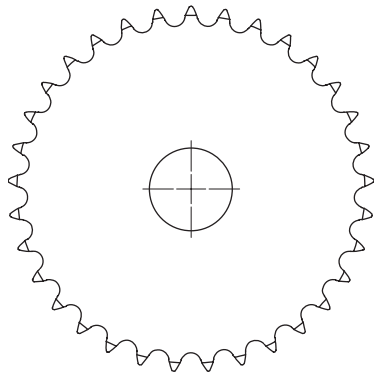
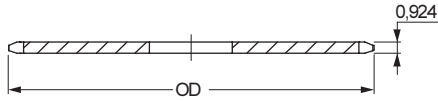

Type B

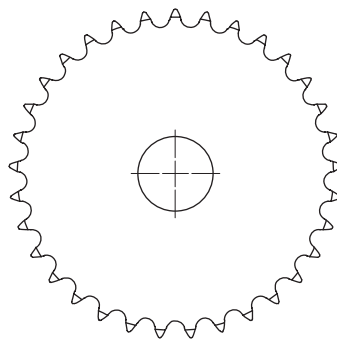
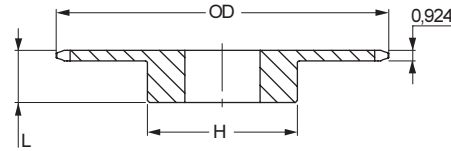

Type C

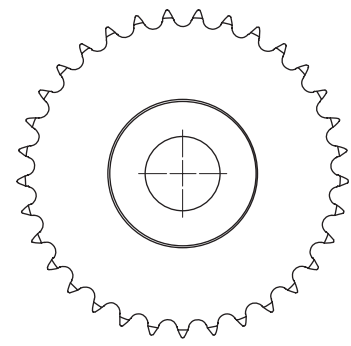
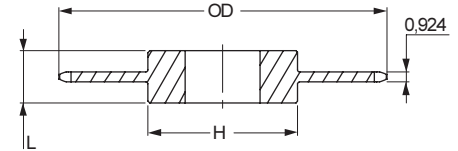

Pilot Bore Type B/C

Type A

No. Teeth	Outside Diameter	Type	Bore		Hub		Weight	Designation	No. Teeth	Outside Diameter	Type	Bore Stock	Weight	Designation
			Min	Max	H	L								
	Inch		Inch	Inch	Inch	Inch	lbs		Inch		Inch	lbs		
8	4,52	-	-	-	-	-	-	-	8	4,52	A	1 1/4	2,40	PHS 120-1A8
9	5,02	B	1 3/8	1 13/16	3 3/8	2 1/4	5,30	PHS 120-1B9	9	5,02	A	1 1/4	3,00	PHS 120-1A9
10	5,52	B	1 3/8	2 1/4	3 3/4	2 1/4	7,10	PHS 120-1B10	10	5,52	A	1 1/4	3,80	PHS 120-1A10
11	6,01	B	1 3/8	2 3/8	3 9/16	2 1/8	7,60	PHS 120-1B11	11	6,01	A	1 1/4	4,80	PHS 120-1A11
12	6,50	B	1 3/8	2 3/4	4 1/8	2 1/8	9,90	PHS 120-1B12	12	6,50	A	1 1/4	5,80	PHS 120-1A12
13	6,99	B	1 3/8	3	4 9/16	2 1/4	12,40	PHS 120-1B13	13	6,99	A	1 1/4	6,70	PHS 120-1A13
14	7,47	B	1 3/8	3 1/4	4 3/4	2 1/4	14,40	PHS 120-1B14	14	7,47	A	1 1/4	8,00	PHS 120-1A14
15	7,96	B	1 3/4	3 3/4	4 3/4	2 3/8	16,70	PHS 120-1B15	15	7,96	A	1 1/4	9,10	PHS 120-1A15
16	8,44	B	1 3/4	3 1/2	5 1/4	2 3/8	19,90	PHS 120-1B16	16	8,44	A	1 1/4	10,60	PHS 120-1A16
17	8,92	B	1 3/4	3 1/2	5 1/4	2 3/8	20,80	PHS 120-1B17	17	8,92	A	1 1/4	12,60	PHS 120-1A17
18	9,41	B	1 3/4	3 1/2	5 1/4	2 3/8	22,20	PHS 120-1B18	18	9,41	A	1 1/4	13,60	PHS 120-1A18
19	9,89	B	1 3/4	3 1/2	5 1/4	2 3/8	24,80	PHS 120-1B19	19	9,89	A	1 1/4	15,10	PHS 120-1A19
20	10,37	B	1 3/4	3 1/2	5 1/4	2 3/8	25,80	PHS 120-1B20	20	10,37	A	1 1/4	16,90	PHS 120-1A20
21	10,85	B	1 3/4	3 1/2	5 1/4	2 3/8	26,70	PHS 120-1B21	21	10,85	A	1 1/4	18,70	PHS 120-1A21
22	11,33	B	1 3/4	3 1/2	5 1/4	2 3/8	28,20	PHS 120-1B22	22	11,33	A	1 1/4	20,00	PHS 120-1A22
23	11,81	B	1 3/4	3 1/2	5 1/4	2 3/8	30,30	PHS 120-1B23	23	11,81	A	1 1/4	22,10	PHS 120-1A23
24	12,29	B	1 3/4	3 1/2	5 1/4	2 3/8	32,10	PHS 120-1B24	24	12,29	A	1 1/4	24,80	PHS 120-1A24
25	12,77	B	1 3/4	3 1/2	5 1/4	2 3/8	34,60	PHS 120-1B25	25	12,77	A	1 1/4	26,80	PHS 120-1A25
26	13,25	B	1 1/2	4	6	2 1/2	40,00	PHS 120-1B26	26	13,25	A	1 1/2	28,30	PHS 120-1A26
27	13,73	-	-	-	-	-	-	-	27	13,73	A	1 1/2	30,90	PHS 120-1A27
28	14,21	B	1 1/2	4	6	2 1/2	44,90	PHS 120-1B28	28	14,21	A	1 1/2	33,60	PHS 120-1A28
30	15,17	B	1 1/2	4	6	2 1/2	50,20	PHS 120-1B30	30	15,17	A	1 1/2	39,00	PHS 120-1A30
32	16,13	B	1 1/2	4	6	2 1/2	56,00	PHS 120-1B32	32	16,13	A	1 1/2	43,90	PHS 120-1A32
33	16,61	-	-	-	-	-	-	-	33	16,61	A	1 1/2	48,20	PHS 120-1A33
34	17,09	-	-	-	-	-	-	-	34	17,09	A	1 1/2	50,00	PHS 120-1A34
35	17,57	B	1 1/2	4	6	2 1/2	62,40	PHS 120-1B35	35	17,57	A	1 1/2	52,00	PHS 120-1A35
36	18,05	B	1 1/2	4	6	2 1/2	66,40	PHS 120-1B36	36	18,05	A	1 1/2	56,00	PHS 120-1A36
40	19,96	C	1 1/2	4	6	3 3/4	92,00	PHS 120-1C40	40	19,96	A	1 1/2	71,00	PHS 120-1A40
42	20,92	C	1 1/2	4	6	3 3/4	98,00	PHS 120-1C42	42	20,92	A	1 1/2	75,00	PHS 120-1A42
45	22,35	C	1 1/2	4	6	3 3/4	99,20	PHS 120-1C45	45	22,35	A	1 1/2	88,00	PHS 120-1A45
48	23,79	C	1 1/2	4	6	4	113,00	PHS 120-1C48	48	23,79	A	1 1/2	103,00	PHS 120-1A48
54	26,65	C	1 1/2	4	6	4	133,00	PHS 120-1C54	54	26,65	A	1 1/2	140,00	PHS 120-1A54
60	29,52	C	1 1/2	5 1/4	7	4	160,00	PHS 120-1C60	60	29,52	A	1 1/2	160,00	PHS 120-1A60
70	34,30	C	1 1/2	5 3/8	7 1/2	4 1/2	206,00	PHS 120-1C70	70	34,30	A	1 1/2	216,00	PHS 120-1A70
80	39,08	C	1 1/2	5 3/8	7 1/2	4 1/2	254,00	PHS 120-1C80	80	39,08	A	1 1/2	284,00	PHS 120-1A80
90	43,85	-	-	-	-	-	-	-	90	43,85	A	1 1/2	358,00	PHS 120-1A90

Maximum bores can accommodate standard keyways. Larger bores are available where a shallow keyway is used or no keyway is required. For hardened teeth sprockets, add "H" after the sprocket profile e.g. PHS 08B-1AH8.



ANSI sprockets

Simplex
Pilot Bore

- ▶ Belts
- ▶ Chains
- ▶ Couplings
- ▶ Bushings and Hubs
- ▶ Sprockets
- ▶ Pulleys
- ▶ Smart tools

ANSI 140-1 1 3/4" Pitch

Type A

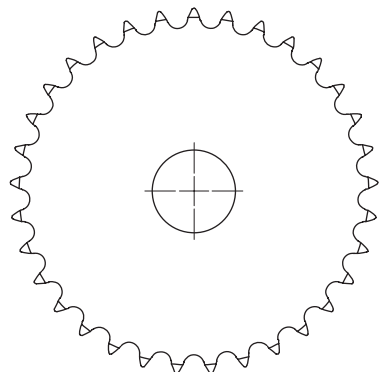
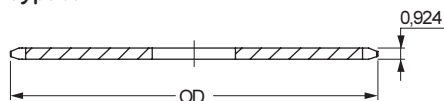

Type B

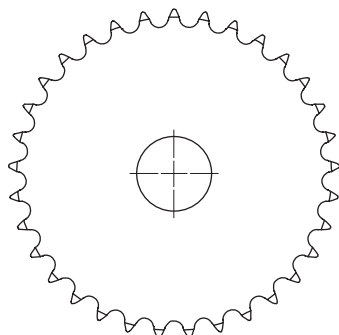
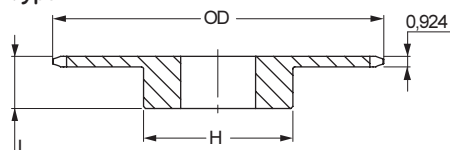

Type C

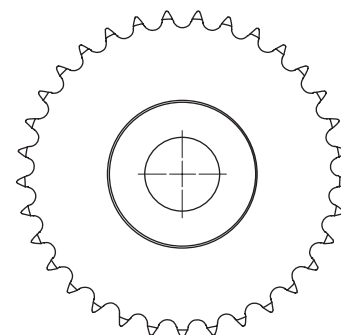
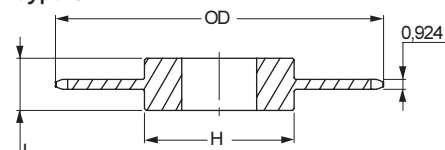

Pilot Bore Type B/C

Type A

No. Teeth	Outside Diameter	Type	Bore		Hub		Weight	Designation	No. Teeth	Outside Diameter	Type	Bore Stock	Weight	Designation
			Min	Max	H	L								
11	7,01	B	1 1/2	2 3/4	4 1/4	2 1/4	11,30	PHS 140-1B11	11	7,01	A	1 1/2	5,00	PHS 140-1A11
12	7,58	B	1 1/2	3	4 1/2	2 1/4	13,20	PHS 140-1B12	12	7,58	A	1 1/2	7,80	PHS 140-1A12
13	8,15	B	1 1/2	3 3/4	5 1/2	2 3/8	18,90	PHS 140-1B13	13	8,15	A	1 1/2	8,20	PHS 140-1A13
14	8,72	B	1 1/2	3 3/4	5 1/2	2 3/8	20,40	PHS 140-1B14	14	8,72	A	1 1/2	10,00	PHS 140-1A14
15	9,28	B	1 1/2	4 1/4	6 1/4	2 3/8	25,10	PHS 140-1B15	15	9,28	A	1 1/2	11,00	PHS 140-1A15
16	9,85	B	1 1/2	4 1/4	6 1/4	2 1/2	27,90	PHS 140-1B16	16	9,85	A	1 1/2	14,00	PHS 140-1A16
17	10,41	B	1 1/2	4 1/4	6 1/4	2 1/2	29,80	PHS 140-1B17	17	10,41	A	1 1/2	16,00	PHS 140-1A17
18	10,98	B	1 1/2	4 1/4	6 1/4	2 1/2	32,00	PHS 140-1B18	18	10,98	A	1 1/2	18,00	PHS 140-1A18
19	11,54	B	1 1/2	4 1/4	6 1/4	2 1/2	34,10	PHS 140-1B19	19	11,54	A	1 1/2	21,00	PHS 140-1A19
20	12,10	B	1 1/2	4 1/4	6 1/4	2 1/2	36,00	PHS 140-1B20	20	12,10	A	1 1/2	23,00	PHS 140-1A20
21	12,66	B	1 1/2	4 1/4	6 1/4	2 1/2	38,70	PHS 140-1B21	21	12,66	A	1 1/2	25,00	PHS 140-1A21
22	13,22	B	1 1/2	4 1/4	6 1/4	2 1/2	40,60	PHS 140-1B22	22	13,22	A	1 1/2	28,00	PHS 140-1A22
23	13,78	B	1 1/2	4 1/4	6 1/4	2 1/2	42,10	PHS 140-1B23	23	13,78	A	1 1/2	30,00	PHS 140-1A23
24	14,34	B	1 1/2	4 1/4	6 1/4	2 1/2	46,20	PHS 140-1B24	24	14,34	A	1 1/2	33,00	PHS 140-1A24
25	14,90	B	1 1/2	4 1/4	6 1/4	2 1/2	47,80	PHS 140-1B25	25	14,90	A	1 1/2	34,00	PHS 140-1A25
26	15,46	B	1 1/2	4 1/4	6 1/4	3	57,20	PHS 140-1B26	26	15,46	A	1 1/2	39,00	PHS 140-1A26
27	16,02	B	1 1/2	4 1/4	6 1/4	3	58,50	PHS 140-1B27	27	16,02	A	1 1/2	41,00	PHS 140-1A27
28	16,58	B	1 1/2	4 1/4	6 1/4	3	62,20	PHS 140-1B28	28	16,58	A	1 1/2	45,00	PHS 140-1A28
30	17,70	B	1 1/2	4 1/4	6 1/4	3	69,80	PHS 140-1B30	30	17,70	A	1 1/2	52,00	PHS 140-1A30
31	18,26	-	-	-	-	-	-	-	31	18,26	-	1 1/2	56,00	PHS 140-1A31
32	18,82	B	1 1/2	4 1/4	6 1/4	3	76,30	PHS 140-1B32	32	18,82	A	1 1/2	60,00	PHS 140-1A32
35	20,49	C	1 1/2	5 1/4	7	4	108,00	PHS 140-1C35	35	20,49	A	1 1/2	73,00	PHS 140-1A35
36	21,05	-	-	-	-	-	-	-	36	21,05	-	1 1/2	77,00	PHS 140-1A36
40	23,29	C	1 1/2	5 1/4	7	4	121,00	PHS 140-1C40	40	23,29	A	1 1/2	93,00	PHS 140-1A40
45	26,08	C	1 1/2	5 1/4	7	4	142,00	PHS 140-1C45	45	26,08	A	1 1/2	131,00	PHS 140-1A45
48	27,75	C	1 1/2	5 1/4	7	4	150,00	PHS 140-1C48	48	27,75	A	1 1/2	134,00	PHS 140-1A48
54	31,10	C	1 1/2	5 1/4	7	4	177,00	PHS 140-1C54	54	31,10	A	1 1/2	173,00	PHS 140-1A54
60	34,44	C	1 1/2	5 1/4	7	5	220,00	PHS 140-1C60	60	34,44	A	1 1/2	219,00	PHS 140-1A60
70	40,02	C	1 1/2	5 3/8	7 1/2	5	282,00	PHS 140-1C70	70	40,02	A	1 1/2	292,00	PHS 140-1A70
80	45,59	C	1 1/2	5 3/8	7 1/2	5	331,00	PHS 140-1C80	80	45,59	A	1 1/2	402,00	PHS 140-1A80

Maximum bores can accommodate standard keyways. Larger bores are available where a shallow keyway is used or no keyway is required. For hardened teeth sprockets, add "H" after the sprocket profile e.g. PHS 08B-1AH8.

ANSI sprockets

Simplex
Pilot Bore



ANSI 160-1 2" Pitch

Type A

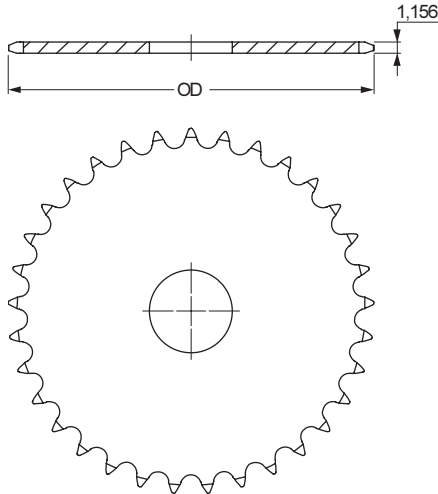

Type B

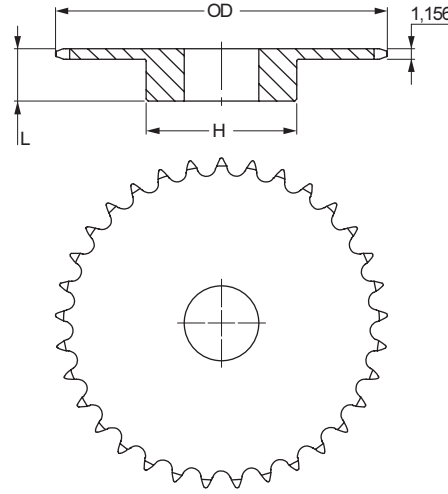

Type C

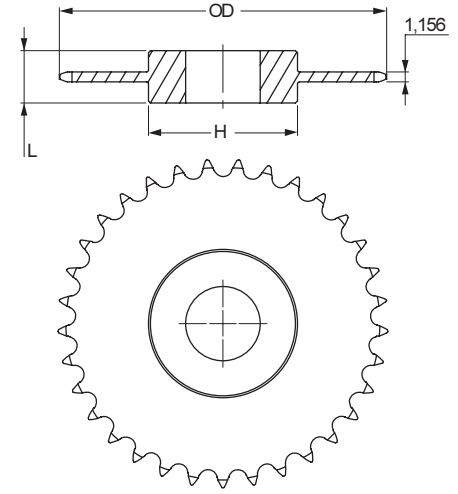

Pilot Bore Type B/C

Type A

No. Teeth	Outside Diameter	Type	Bore		Hub		Weight	Designation	No. Teeth	Outside Diameter	Type	Bore Stock	Weight	Designation
			Min	Max	H	L								
8	6.03	B	1 1/2	1 7/8	3 1/4	2 1/4	8.00	PHS 160-1B8	8	6.03	A	1 1/2	5.00	PHS 160-1A8
9	6.70	B	1 1/2	2 1/8	3 5/8	2 1/4	10.00	PHS 160-1B9	9	6.70	A	1 1/2	7.00	PHS 160-1A9
10	7.36	B	1 1/2	2 3/4	4 1/8	2 1/4	12.00	PHS 160-1B10	10	7.36	A	1 1/2	8.00	PHS 160-1A10
11	8.01	B	1 1/2	3 1/4	4 3/4	2 1/2	17.00	PHS 160-1B11	11	8.01	A	1 1/2	10.00	PHS 160-1A11
12	8.66	B	1 1/2	3 3/4	5 1/2	2 1/2	21.00	PHS 160-1B12	12	8.66	A	1 1/2	12.00	PHS 160-1A12
13	9.31	B	1 1/2	4	6	2 3/4	28.00	PHS 160-1B13	13	9.31	A	1 1/2	16.00	PHS 160-1A13
14	9.96	B	1 1/2	4 1/2	6 1/2	2 3/4	32.00	PHS 160-1B14	14	9.96	A	1 1/2	17.00	PHS 160-1A14
15	10.61	B	1 1/2	5 1/4	7	2 3/4	37.00	PHS 160-1B15	15	10.61	A	1 1/2	21.00	PHS 160-1A15
16	11.26	B	1 1/2	5 3/4	7	2 3/4	41.00	PHS 160-1B16	16	11.26	A	1 1/2	24.00	PHS 160-1A16
17	11.90	B	1 1/2	5 3/4	7	2 3/4	45.00	PHS 160-1B17	17	11.90	A	1 1/2	27.00	PHS 160-1A17
18	12.54	B	1 1/2	5 3/4	7	2 3/4	48.00	PHS 160-1B18	18	12.54	A	1 1/2	30.00	PHS 160-1A18
19	13.19	B	1 1/2	5 3/4	7	2 3/4	52.00	PHS 160-1B19	19	13.19	A	1 1/2	34.00	PHS 160-1A19
20	13.83	B	1 1/2	5 3/4	7	2 3/4	56.00	PHS 160-1B20	20	13.83	A	1 1/2	38.00	PHS 160-1A20
21	14.47	B	1 1/2	5 3/4	7	2 3/4	59.00	PHS 160-1B21	21	14.47	A	1 1/2	42.00	PHS 160-1A21
22	15.11	B	1 1/2	5 3/4	7	2 3/4	65.00	PHS 160-1B22	22	15.11	A	1 1/2	46.00	PHS 160-1A22
23	15.75	B	1 1/2	5 3/4	7	2 3/4	68.00	PHS 160-1B23	23	15.75	A	1 1/2	50.00	PHS 160-1A23
24	16.39	B	1 1/2	5 3/4	7	3	77.00	PHS 160-1B24	24	16.39	A	1 1/2	56.00	PHS 160-1A24
25	17.03	B	1 1/2	5 3/4	7	3	81.00	PHS 160-1B25	25	17.03	A	1 1/2	61.00	PHS 160-1A25
26	17.67	B	1 1/2	5 3/4	7	3	86.00	PHS 160-1B26	26	17.67	A	1 1/2	65.00	PHS 160-1A26
27	18.31	B	1 1/2	5 3/4	7	3	91.00	PHS 160-1B27	27	18.31	A	1 1/2	71.00	PHS 160-1A27
28	18.95	B	1 1/2	5 3/4	7	3	98.00	PHS 160-1B28	28	18.95	A	1 1/2	77.00	PHS 160-1A28
30	20.23	B	1 1/2	5 3/4	7	3	108.00	PHS 160-1B30	30	20.23	A	1 1/2	90.00	PHS 160-1A30
35	23.42	C	1 1/2	5 1/2	8	4 1/2	154.00	PHS 160-1C35	35	23.42	A	1 1/2	121.00	PHS 160-1A35
40	26.61	C	1 1/2	5 1/2	8	4 1/2	196.00	PHS 160-1C40	40	26.61	A	1 1/2	138.00	PHS 160-1A40
45	29.80	C	1 1/2	5 1/2	8	5	234.00	PHS 160-1C45	45	29.80	A	1 1/2	204.00	PHS 160-1A45
54	35.54	C	1 1/2	5 1/2	8	5	276.00	PHS 160-1C54	54	35.54	A	1 1/2	294.00	PHS 160-1A54
60	39.36	C	1 1/2	5 1/2	8	5	329.00	PHS 160-1C60	60	39.36	A	1 1/2	366.00	PHS 160-1A60
70	45.73	C	1 1/2	5 1/2	8	5	446.00	PHS 160-1C70	70	45.73	A	1 1/2	507.00	PHS 160-1A70
80	52.10	C	1 1/2	5 1/2	8	6	612.00	PHS 160-1C80	80	52.10	A	1 1/2	656.00	PHS 160-1A80

Maximum bores can accommodate standard keyways. Larger bores are available where a shallow keyway is used or no keyway is required. For hardened teeth sprockets, add "H" after the sprocket profile e.g. PHS 08B-1AH8.



ANSI sprockets

Simplex
Pilot Bore

- ▶ Belts
- ▶ Chains
- ▶ Couplings
- ▶ Bushings and Hubs
- ▶ Sprockets
- ▶ Pulleys
- ▶ Smart tools

ANSI 180-1 2 1/4" Pitch

Type A

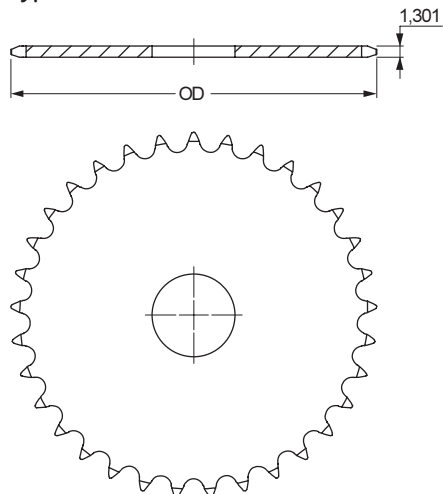

Type B

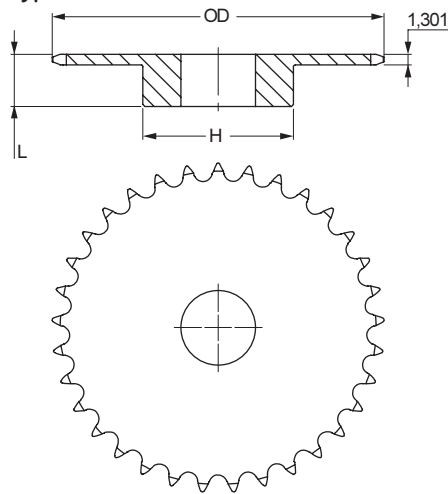

Type C

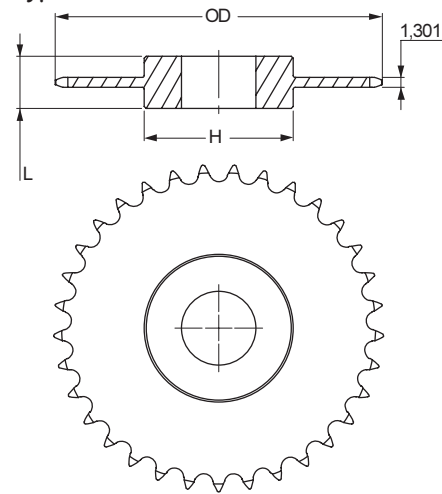

Pilot Bore Type B/C

Type A

No. Teeth	Outside Diameter	Type	Bore		Hub		Weight	Designation	No. Teeth	Outside Diameter	Type	Bore Stock	Weight	Designation
			Min	Max	H	L								
	Inch		Inch	Inch	Inch	Inch	lbs		Inch		Inch	lbs		
11	9.01	B	1 1/2	3 5/8	5 1/2	3	29.00	PHS 180-1B11	11	9.01	A	1 1/2	14.00	PHS 180-1A11
12	9.75	B	1 1/2	4	6	3	32.00	PHS 180-1B12	12	9.75	A	1 1/2	16.00	PHS 180-1A12
13	10.48	B	1 1/2	4 5/8	6 3/4	3 1/8	40.00	PHS 180-1B13	13	10.48	A	1 1/2	20.00	PHS 180-1A13
14	11.21	B	1 1/2	5 1/4	7	3 1/8	44.00	PHS 180-1B14	14	11.21	A	1 1/2	24.00	PHS 180-1A14
15	11.93	B	1 1/2	5 1/4	7	3 1/8	48.00	PHS 180-1B15	15	11.93	A	1 1/2	28.00	PHS 180-1A15
16	12.66	B	1 1/2	5 3/4	7	3 1/8	52.00	PHS 180-1B16	16	12.66	A	1 1/2	32.00	PHS 180-1A16
17	13.39	B	1 1/2	5 3/4	7	3 1/8	58.00	PHS 180-1B17	17	13.39	A	1 1/2	37.00	PHS 180-1A17
18	14.11	B	1 1/2	5 3/4	7	3 1/8	63.00	PHS 180-1B18	18	14.11	A	1 1/2	43.00	PHS 180-1A18
19	14.83	B	1 1/2	5 3/8	7 1/2	3 3/8	74.00	PHS 180-1B19	19	14.83	A	1 1/2	47.00	PHS 180-1A19
20	15.56	B	1 1/2	5 3/8	7 1/2	3 3/8	81.00	PHS 180-1B20	20	15.56	A	1 1/2	53.00	PHS 180-1A20
21	16.28	B	1 1/2	5 3/8	7 1/2	3 3/8	83.00	PHS 180-1B21	21	16.28	A	1 1/2	57.00	PHS 180-1A21
22	17.00	B	1 1/2	5 3/8	7 1/2	3 3/8	92.00	PHS 180-1B22	22	17.00	A	1 1/2	62.00	PHS 180-1A22
23	17.72	B	1 1/2	5 3/8	7 1/2	3 3/8	99.00	PHS 180-1B23	23	17.72	A	1 1/2	69.00	PHS 180-1A23
24	18.44	B	1 1/2	5 3/8	7 1/2	3 3/8	105.00	PHS 180-1B24	24	18.44	A	1 1/2	77.00	PHS 180-1A24
25	19.16	B	1 1/2	5 3/8	7 1/2	3 3/8	113.00	PHS 180-1B25	25	19.16	A	1 1/2	84.00	PHS 180-1A25
28	21.32	B	1 1/2	5 1/2	8	3 1/2	135.00	PHS 180-1B28	28	21.32	A	1 1/2	104.00	PHS 180-1A28
30	22.76	C	1 1/2	5 3/4	8 1/2	4 3/8	180.00	PHS 180-1C30	30	22.76	A	1 1/2	120.00	PHS 180-1A30
35	26.35	C	1 1/2	5 3/4	8 1/2	4 3/8	222.00	PHS 180-1C35	35	26.35	A	1 1/2	172.00	PHS 180-1A35
40	29.94	C	1 1/2	5 3/4	8 1/2	4 3/8	270.00	PHS 180-1C40	40	29.94	A	1 1/2	229.00	PHS 180-1A40
45	33.53	C	1 1/2	6	9	5	315.00	PHS 180-1C45	45	33.53	A	1 1/2	284.00	PHS 180-1A45
54	39.98	C	1 1/2	6	9	5	477.00	PHS 180-1C54	54	39.98	A	1 1/2	420.00	PHS 180-1A54
60	44.28	C	1 1/2	6 1/2	9 1/2	5 3/8	489.00	PHS 180-1C60	60	44.28	A	1 1/2	505.00	PHS 180-1A60

Maximum bores can accommodate standard keyways. Larger bores are available where a shallow keyway is used or no keyway is required. For hardened teeth sprockets, add "H" after the sprocket profile e.g. PHS 08B-1AH8.

ANSI sprockets

Simplex
Pilot Bore



ANSI 200-1 2 1/2" Pitch

Type A

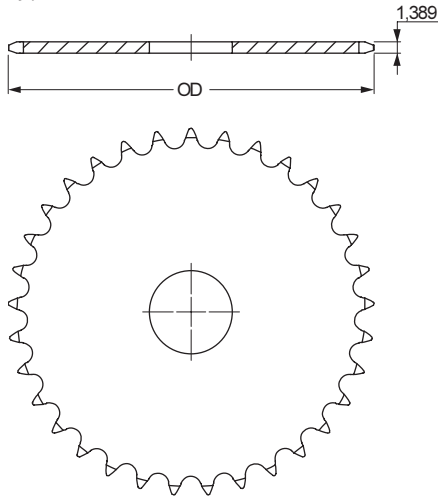

Type B

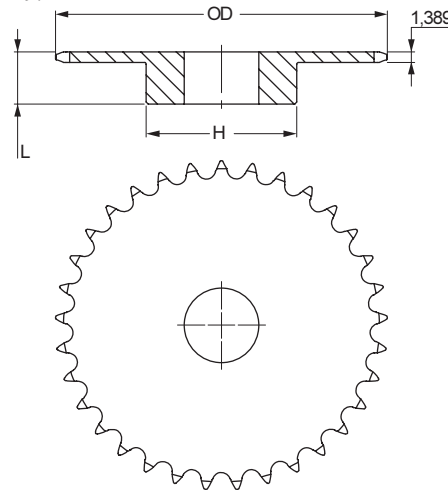

Type C

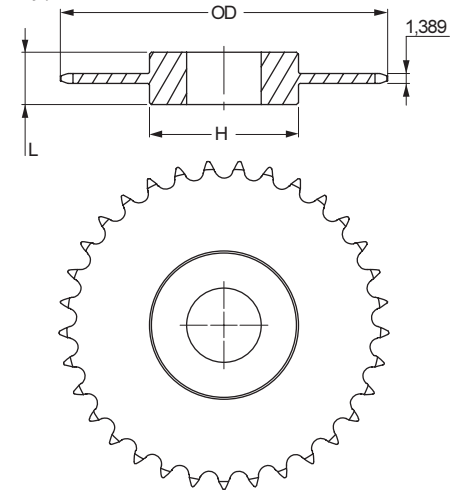

Pilot Bore Type B/C

Type A

No. Teeth	Outside Diameter	Type	Bore		Hub		Weight	Designation	No. Teeth	Outside Diameter	Type	Bore Stock	Weight	Designation
			Min	Max	H	L								
10	9,20	B	1 1/2	3 3/4	5 1/2	3	26,00	PHS 200-1B10	10	9,20	A	1 1/2	16,00	PHS 200-1A10
11	10,02	B	1 1/2	4	6	3	33,00	PHS 200-1B11	11	10,02	A	1 1/2	20,00	PHS 200-1A11
12	10,83	B	1 1/2	4 1/2	6 1/2	3	37,00	PHS 200-1B12	12	10,83	A	1 1/2	24,00	PHS 200-1A12
13	11,64	B	1 1/2	5 1/4	7	3	46,00	PHS 200-1B13	13	11,64	A	1 1/2	30,00	PHS 200-1A13
14	12,46	B	1 1/2	5 3/8	7 1/2	3 1/2	59,00	PHS 200-1B14	14	12,46	A	1 1/2	32,00	PHS 200-1A14
15	13,26	B	1 1/2	5 3/8	7 1/2	3 1/2	64,00	PHS 200-1B15	15	13,26	A	1 1/2	40,00	PHS 200-1A15
16	14,07	B	1 1/2	5 3/8	7 1/2	3 1/2	72,00	PHS 200-1B16	16	14,07	A	1 1/2	46,00	PHS 200-1A16
17	14,87	B	1 1/2	5 3/8	7 1/2	3 1/2	76,00	PHS 200-1B17	17	14,87	A	1 1/2	51,00	PHS 200-1A17
18	15,68	B	1 1/2	5 3/8	7 1/2	3 1/2	84,00	PHS 200-1B18	18	15,68	A	1 1/2	57,00	PHS 200-1A18
19	16,48	B	1 1/2	5 3/8	7 1/2	3 1/2	91,00	PHS 200-1B19	19	16,48	A	1 1/2	65,00	PHS 200-1A19
20	17,29	B	1 1/2	5 3/8	7 1/2	3 1/2	98,00	PHS 200-1B20	20	17,29	A	1 1/2	72,00	PHS 200-1A20
21	18,09	B	1 1/2	5 3/8	7 1/2	3 1/2	106,00	PHS 200-1B21	21	18,09	A	1 1/2	82,00	PHS 200-1A21
22	18,89	B	1 1/2	5 3/4	8 1/2	4	131,00	PHS 200-1B22	22	18,89	A	1 1/2	88,00	PHS 200-1A22
23	19,69	B	1 1/2	5 3/4	8 1/2	4	136,00	PHS 200-1B23	23	19,69	A	1 1/2	95,00	PHS 200-1A23
24	20,49	B	1 1/2	5 3/4	8 1/2	4	142,00	PHS 200-1B24	24	20,49	A	1 1/2	105,00	PHS 200-1A24
25	21,29	B	1 1/2	5 3/4	8 1/2	4	153,00	PHS 200-1B25	25	21,29	A	1 1/2	113,00	PHS 200-1A25
26	22,09	C	1 1/2	5 3/4	8 1/2	4 1/2	178,00	PHS 200-1C26	26	22,09	A	1 1/2	124,00	PHS 200-1A26
28	23,69	C	1 1/2	5 3/4	8 1/2	4 1/2	195,00	PHS 200-1C28	28	23,69	A	1 1/2	144,00	PHS 200-1A28
30	25,29	C	1 1/2	5 3/4	8 1/2	4 1/2	212,00	PHS 200-1C30	30	25,29	A	1 1/2	167,00	PHS 200-1A30
32	26,88	C	1 1/2	5 3/4	8 1/2	4 1/2	220,00	PHS 200-1C32	32	26,88	A	1 1/2	195,00	PHS 200-1A32
35	29,28	C	1 1/2	5 3/4	8 1/2	4 1/2	254,00	PHS 200-1C35	35	29,28	A	1 1/2	227,00	PHS 200-1A35
40	33,27	C	1 1/2	6	9	5	320,00	PHS 200-1C40	40	33,27	A	1 1/2	301,00	PHS 200-1A40
45	37,25	C	1 1/2	6	9	5	364,00	PHS 200-1C45	45	37,25	A	1 1/2	390,00	PHS 200-1A45
54	44,42	C	1 1/2	6 1/2	9 1/2	5 1/2	512,00	PHS 200-1C54	54	44,42	A	1 1/2	555,00	PHS 200-1A54
60	49,20	C	1 1/2	6 1/2	9 1/2	5 1/2	654,00	PHS 200-1C60	60	49,20	A	1 1/2	692,00	PHS 200-1A60

Maximum bores can accommodate standard keyways. Larger bores are available where a shallow keyway is used or no keyway is required. For hardened teeth sprockets, add "H" after the sprocket profile e.g. PHS 08B-1AH8.



ANSI sprockets

Simplex
Pilot Bore

- ▶ Belts
- ▶ Chains
- ▶ Couplings
- ▶ Bushings and Hubs
- ▶ Sprockets
- ▶ Pulleys
- ▶ Smart tools

ANSI 240-1 3" Pitch

Type A

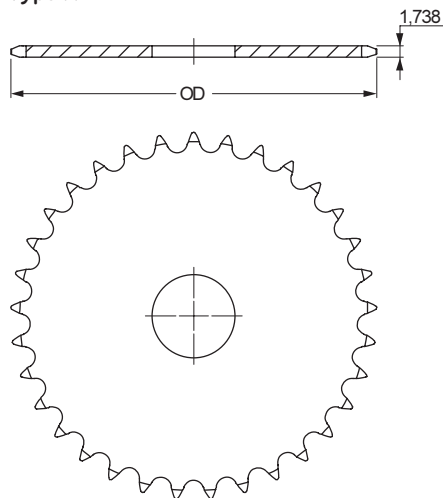

Type B

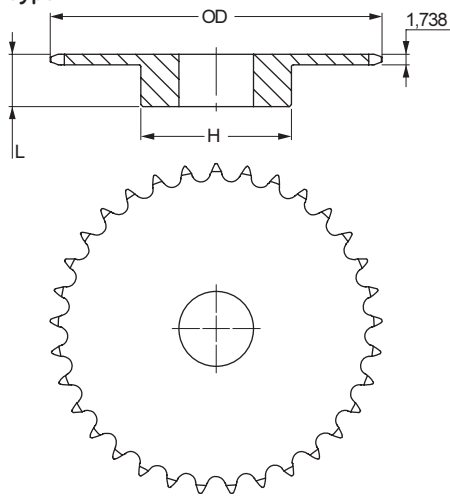

Type C

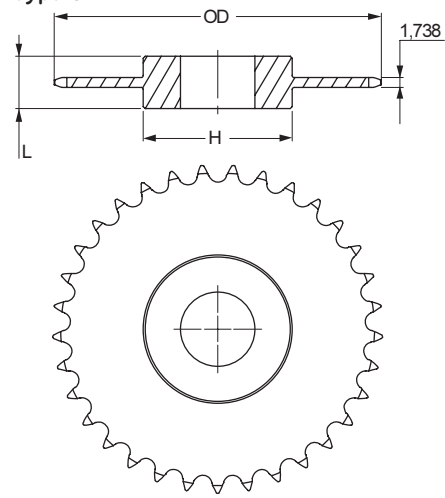

Pilot Bore Type B/C

Type A

No. Teeth	Outside Diameter	Type	Bore		Hub		Weight	Designation	No. Teeth	Outside Diameter	Type	Bore Stock	Weight	Designation		
			Min	Max	H	L									Inch	lbs
			Inch	Inch	Inch	Inch										
10	11.03	B	1 1/2	4 1/2	6 1/2	3 3/8	49,00	PHS 240-1B10	10	11.03	A	1 1/2	30,00	PHS 240-1A10		
11	12.02	B	1 1/2	4 3/4	7	3 7/8	66,00	PHS 240-1B11	11	12.02	A	1 1/2	37,00	PHS 240-1A11		
12	13.00	B	1 1/2	5 3/8	7 1/2	3 7/8	72,00	PHS 240-1B12	12	13.00	A	1 1/2	45,00	PHS 240-1A12		
13	13.97	B	1 1/2	5 3/8	7 1/2	3 7/8	81,00	PHS 240-1B13	13	13.97	A	1 1/2	54,00	PHS 240-1A13		
14	14.94	B	1 1/2	5 3/8	7 1/2	3 7/8	88,00	PHS 240-1B14	14	14.94	A	1 1/2	62,00	PHS 240-1A14		
15	15.91	B	1 1/2	5 3/8	7 1/2	3 7/8	98,00	PHS 240-1B15	15	15.91	A	1 1/2	68,00	PHS 240-1A15		
16	16.88	B	1 1/2	5 1/2	8	4 1/8	120,00	PHS 240-1B16	16	16.88	A	1 1/2	82,00	PHS 240-1A16		
17	17.85	B	1 1/2	5 1/2	8	4 1/8	137,00	PHS 240-1B17	17	17.85	A	1 1/2	93,00	PHS 240-1A17		
18	18.81	B	1 1/2	5 1/2	8	4 1/8	142,00	PHS 240-1B18	18	18.81	A	1 1/2	108,00	PHS 240-1A18		
19	19.78	B	1 1/2	5 1/2	8	4 1/8	154,00	PHS 240-1B19	19	19.78	A	1 1/2	120,00	PHS 240-1A19		
20	20.74	B	1 1/2	5 1/2	8	4 1/8	169,00	PHS 240-1B20	20	20.74	A	1 1/2	128,00	PHS 240-1A20		
21	21.71	B	1 1/2	5 1/2	8	4 1/8	186,00	PHS 240-1B21	21	21.71	A	1 1/2	148,00	PHS 240-1A21		
25	25.55	B	1 1/2	5 1/2	8	4 1/8	254,00	PHS 240-1B25	25	25.55	A	1 1/2	208,00	PHS 240-1A25		
30	30.34	C	1 1/2	6	9	6 3/4	398,00	PHS 240-1C30	30	30.34	A	1 1/2	310,00	PHS 240-1A30		
35	35.13	C	1 1/2	6	9	6 3/4	527,00	PHS 240-1C35	35	35.13	A	1 1/2	416,00	PHS 240-1A35		
40	39.92	C	1 1/2	7	10	6 3/4	672,00	PHS 240-1C40	40	39.92	A	1 1/2	548,00	PHS 240-1A40		
45	44.70	C	1 1/2	7	10	6 3/4	850,00	PHS 240-1C45	45	44.70	A	1 1/2	702,00	PHS 240-1A45		
54	53.31	C	1 1/2	7	10	6 3/4	1148,00	PHS 240-1C54	54	53.31	A	1 1/2	1022,00	PHS 240-1A54		
60	59.04	C	1 1/2	7	10	6 3/4	1419,00	PHS 240-1C60	60	59.04	A	1 1/2	1268,00	PHS 240-1A60		

Maximum bores can accommodate standard keyways. Larger bores are available where a shallow keyway is used or no keyway is required. For hardened teeth sprockets, add "H" after the sprocket profile e.g. PHS 08B-1AH8.

ANSI sprockets

Simplex
Taper Bushed



ANSI 35-1 3/8" Pitch

Taper Bushed Type B

No. Teeth	Diameter		Type	Bushing Size	Bore		Dimensions		Weight		Designation
	Outside	Pitch			Min	Max	L	H	Rim	Bushing	
18	2,35	2,16	B	1008	3/8	1	7/8	1 7/8	0,4	0,3	PHS 35-1TB18
19	2,47	2,28	B	1008	3/8	1	7/8	1 13/16	0,5	0,3	PHS 35-1TB19
20	2,59	2,40	B	1008	3/8	1	7/8	1 15/16	0,6	0,3	PHS 35-1TB20
21	2,71	2,52	B	1008	3/8	1	7/8	2 1/16	0,7	0,3	PHS 35-1TB21
22	2,88	2,63	B	1210	5/8	1 1/4	1	2 3/8	0,8	0,6	PHS 35-1TB22
23	2,95	2,75	B	1210	5/8	1 1/4	1	2 7/16	0,9	0,6	PHS 35-1TB23
24	3,07	2,87	B	1210	5/8	1 1/4	1	2 7/16	0,9	0,6	PHS 35-1TB24
25	3,19	2,99	B	1210	5/8	1 1/4	1	2 7/16	1,2	0,6	PHS 35-1TB25
26	3,31	3,11	B	1610	1/2	1 5/8	1	2 7/8	1,1	0,9	PHS 35-1TB26
28	3,55	3,35	B	1610	1/2	1 5/8	1	2 7/8	1,2	0,9	PHS 35-1TB28
30	3,79	3,59	B	1610	1/2	1 5/8	1	3 1/8	1,2	0,9	PHS 35-1TB30
32	4,03	3,83	B	1610	1/2	1 5/8	1	3 1/4	1,3	0,9	PHS 35-1TB32
35	4,39	4,18	B	1610	1/2	1 5/8	1	3 1/4	1,4	0,9	PHS 35-1TB35
36	4,51	4,30	B	1610	1/2	1 5/8	1	3 1/4	1,4	0,9	PHS 35-1TB36
40	4,99	4,79	B	1610	1/2	1 5/8	1	3 1/4	1,9	0,9	PHS 35-1TB40
42	5,23	5,02	B	1610	1/2	1 5/8	1	3 1/4	2,0	0,9	PHS 35-1TB42
45	5,59	5,38	B	1610	1/2	1 5/8	1	3 1/4	2,1	0,9	PHS 35-1TB45
48	5,95	5,73	B	1610	1/2	1 5/8	1	3 1/4	2,3	0,9	PHS 35-1TB48
54	6,66	6,45	B	1610	1/2	1 5/8	1	3 1/4	2,6	0,9	PHS 35-1TB54
60	7,38	7,17	B	1610	1/2	1 5/8	1	3 1/4	3,0	0,9	PHS 35-1TB60
70	8,57	8,36	B	1610	1/2	1 5/8	1	3 1/4	3,7	0,9	PHS 35-1TB70
72	8,81	8,60	B	1610	1/2	1 5/8	1	3 1/4	3,9	0,9	PHS 35-1TB72
80	9,77	9,55	B	1610	1/2	1 5/8	1	3 1/4	4,5	0,9	PHS 35-1TB80
84	10,25	10,03	B	1610	1/2	1 5/8	1	3 1/4	4,9	0,9	PHS 35-1TB84
96	11,68	11,46	B	1610	1/2	1 5/8	1	3 1/4	6,0	0,9	PHS 35-1TB96
112	13,59	13,37	B	1610	1/2	1 5/8	1	3 1/4	7,8	0,9	PHS 35-1TB112

For hardened teeth sprockets, add "H" after the sprocket profile e.g. PHS 08B-1AH8.

Type B

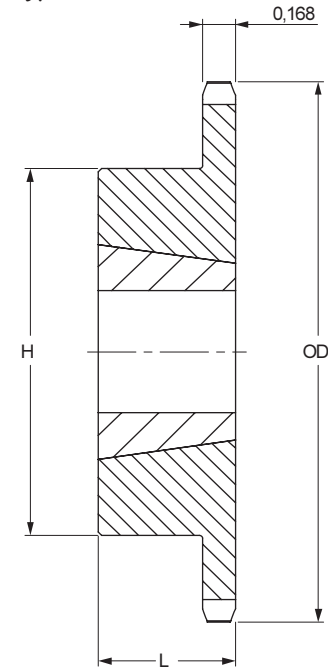

ANSI 41-1 1/2" Pitch

Taper Bushed Type B

No. Teeth	Diameter		Type	Bushing Size	Bore		Dimensions		Weight		Designation
	Outside	Pitch			Min	Max	L	H	Rim	Bushing	
14	2,49	2,25	B	1008	3/8	1	7/8	1 7/8	0,4	0,3	PHS 41-1TB14
15	2,65	2,40	B	1008	3/8	1	7/8	1 7/8	0,5	0,3	PHS 41-1TB15
16	2,81	2,50	B	1008	3/8	1	7/8	2	0,6	0,3	PHS 41-1TB16
17	2,97	2,72	B	1210	5/8	1 1/4	1	2 3/8	0,7	0,6	PHS 41-1TB17
18	3,14	2,88	B	1210	5/8	1 1/4	1	3 3/8	0,9	0,6	PHS 41-1TB18
19	3,30	3,04	B	1210	5/8	1 1/4	1	2 1/2	1,1	0,6	PHS 41-1TB19
20	3,46	3,20	B	1610	1/2	1 5/8	1	2 7/8	1,1	0,9	PHS 41-1TB20
21	3,62	3,36	B	1610	1/2	1 5/8	1	3	1,2	0,9	PHS 41-1TB21
22	3,78	3,51	B	1610	1/2	1 5/8	1	3	1,3	0,9	PHS 41-1TB22
23	3,94	3,67	B	1610	1/2	1 5/8	1	3	1,4	0,9	PHS 41-1TB23
24	4,10	3,83	B	1610	1/2	1 5/8	1	3	1,4	0,9	PHS 41-1TB24
25	4,26	3,99	B	1610	1/2	1 5/8	1	3	1,5	0,9	PHS 41-1TB25
26	4,42	4,15	B	1610	1/2	1 5/8	1	3	1,5	0,9	PHS 41-1TB26
28	4,74	4,47	B	1610	1/2	1 5/8	1	3	1,7	0,9	PHS 41-1TB28
30	5,06	4,78	B	1610	1/2	1 5/8	1	3	1,8	0,9	PHS 41-1TB30
32	5,38	5,10	B	1610	1/2	1 5/8	1	3	1,9	0,9	PHS 41-1TB32
35	5,86	5,58	B	1610	1/2	1 5/8	1	3	2,3	0,9	PHS 41-1TB35
36	6,02	5,74	B	1610	1/2	1 5/8	1	3	2,4	0,9	PHS 41-1TB36
40	6,65	6,37	B	1610	1/2	1 5/8	1	3	2,7	0,9	PHS 41-1TB40
45	7,45	7,17	B	1610	1/2	1 5/8	1	3	3,5	0,9	PHS 41-1TB45
48	7,93	7,64	B	1610	1/2	1 5/8	1	3	4,1	0,9	PHS 41-1TB48
54	8,88	8,60	B	1610	1/2	1 5/8	1	3	4,9	0,9	PHS 41-1TB54
60	9,84	9,55	B	1610	1/2	1 5/8	1	3	5,7	0,9	PHS 41-1TB60
70	11,43	11,14	B	1610	1/2	1 5/8	1	3	7,4	0,9	PHS 41-1TB70
72	11,75	11,46	B	1610	1/2	1 5/8	1	3	8,2	0,9	PHS 41-1TB72
80	13,03	12,74	B	1610	1/2	1 5/8	1	3	9,6	0,9	PHS 41-1TB80
96	15,57	15,28	B	1610	1/2	1 5/8	1	3	13,1	0,9	PHS 41-1TB96

For hardened teeth sprockets, add "H" after the sprocket profile e.g. PHS 08B-1AH8.

Type B

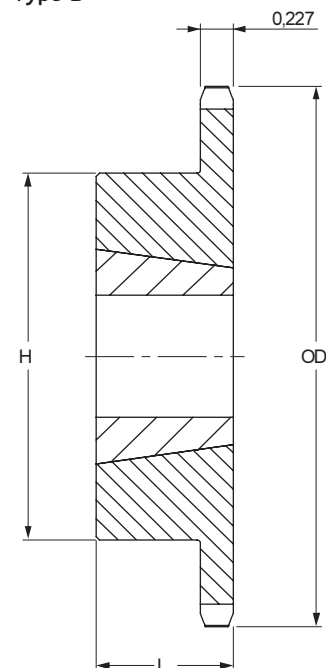



ANSI sprockets

Simplex

Taper Bushed

- ▶ Belts
- ▶ Chains
- ▶ Couplings
- ▶ Bushings and Hubs
- ▶ Sprockets
- ▶ Pulleys
- ▶ Smart tools

ANSI 40-1 1/2" Pitch

Taper Bushed Type B

No. Teeth	Diameter		Type	Bushing Size	Bore		Dimensions		Weight		Designation
	Outside	Pitch			Min	Max	L	H	Rim	Bushing	
	Inch	Inch			Inch	Inch	Inch	Inch	lbs	lbs	
14	2,49	2,25	B	1008	3/8	1	7/8	1 13/16	0,3	0,3	PHS 40-1TB14
15	2,65	2,40	B	1008	3/8	1	7/8	1 13/16	0,4	0,3	PHS 40-1TB15
16	2,81	2,56	B	1008	3/8	1	7/8	1 15/16	0,5	0,3	PHS 40-1TB16
17	2,98	2,72	B	1210	5/8	1 1/4	1	2 3/8	0,5	0,3	PHS 40-1TB17
18	3,13	2,88	B	1210	5/8	1 1/4	1	2 15/32	0,6	0,6	PHS 40-1TB18
19	3,30	3,04	B	1210	5/8	1 1/4	1	2 15/32	0,7	0,6	PHS 40-1TB19
20	3,46	3,20	B	1610	1/2	1 5/8	1	2 25/32	0,7	0,9	PHS 40-1TB20
21	3,62	3,36	B	1610	1/2	1 5/8	1	2 25/32	0,8	0,9	PHS 40-1TB21
22	3,78	3,51	B	1610	1/2	1 5/8	1	2 25/32	0,9	0,9	PHS 40-1TB22
23	3,94	3,67	B	1610	1/2	1 5/8	1	3	1,0	0,9	PHS 40-1TB23
24	4,10	3,83	B	1610	1/2	1 5/8	1	3 1/4	1,4	0,9	PHS 40-1TB24
25	4,26	3,99	B	1610	1/2	1 5/8	1	3 1/4	1,5	0,9	PHS 40-1TB25
26	4,42	4,15	B	1610	1/2	1 5/8	1	3 1/4	1,7	0,9	PHS 40-1TB26
28	4,74	4,47	B	1610	1/2	1 5/8	1	3	1,8	0,9	PHS 40-1TB28
30	5,06	4,78	B	1610	1/2	1 5/8	1	3	1,9	0,9	PHS 40-1TB30
32	5,38	5,10	B	1610	1/2	1 5/8	1	3	1,9	0,9	PHS 40-1TB32
35	5,86	5,58	B	1610	1/2	1 5/8	1	3	2,3	0,9	PHS 40-1TB35
36	6,01	5,74	B	1610	1/2	1 5/8	1	3	2,4	0,9	PHS 40-1TB36
40	6,65	6,37	B	1610	1/2	1 5/8	1	3	2,8	0,9	PHS 40-1TB40
42	6,97	6,69	B	1610	1/2	1 5/8	1	3	2,9	0,9	PHS 40-1TB42
45	7,45	7,17	B	1610	1/2	1 5/8	1	3	3,5	0,9	PHS 40-1TB45
48	7,93	7,64	B	1610	1/2	1 5/8	1	3	4,0	0,9	PHS 40-1TB48
54	8,88	8,60	B	1610	1/2	1 5/8	1	3	4,9	0,9	PHS 40-1TB54
60	9,84	9,55	B	1610	1/2	1 5/8	1	3	6,0	0,9	PHS 40-1TB60
70	11,43	11,14	B	2012	3/4	2	1 1/4	3 7/16	8,2	1,7	PHS 40-1TB70
72	11,75	11,46	B	2012	3/4	2	1 1/4	3 7/16	9,0	1,7	PHS 40-1TB72
80	13,03	12,74	B	2012	3/4	2	1 1/4	3 7/16	10,8	1,7	PHS 40-1TB80
84	13,66	13,37	B	2012	3/4	2	1 1/4	3 7/16	11,3	1,7	PHS 40-1TB84
96	15,57	15,28	B	2012	3/4	2	1 1/4	3 7/16	14,6	1,7	PHS 40-1TB96
112	18,12	17,83	B	2517	3/4	2 1/2	1 3/4	4 1/4	20,5	1,7	PHS 40-1TB112

For hardened teeth sprockets, add "H" after the sprocket profile e.g. PHS 08B-1AH8.

Type B

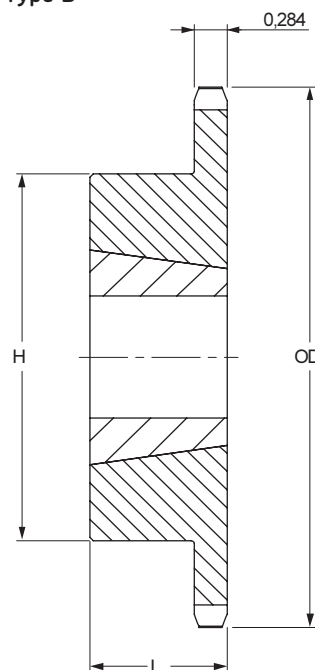

ANSI 50-1 5/8" Pitch

Taper Bushed Type B

No. Teeth	Diameter		Type	Bushing Size	Bore		Dimensions		Weight		Designation
	Outside	Pitch			Min	Max	L	H	Rim	Bushing	
	Inch	Inch			Inch	Inch	Inch	Inch	lbs	lbs	
12	2,71	2,42	B	1008	3/8	1	7/8	1 15/16	0,5	0,3	PHS 50-1TB12
13	2,91	2,61	B	1008	3/8	1	7/8	1 15/16	0,5	0,3	PHS 50-1TB13
14	3,11	2,81	B	1008	3/8	1	7/8	1 15/16	0,6	0,3	PHS 50-1TB14
15	3,31	3,01	B	1210	5/8	1 1/4	1	2 15/32	0,7	0,6	PHS 50-1TB15
16	3,52	3,20	B	1610	1/2	1 5/8	1	2 25/32	0,7	0,9	PHS 50-1TB16
17	3,72	3,40	B	1610	1/2	1 5/8	1	2 25/32	0,8	0,9	PHS 50-1TB17
18	3,92	3,60	B	1610	1/2	1 5/8	1	2 25/32	0,9	0,9	PHS 50-1TB18
19	4,12	3,80	B	1610	1/2	1 5/8	1	3	1,3	0,9	PHS 50-1TB19
20	4,32	4,00	B	1610	1/2	1 5/8	1	3 1/4	1,6	0,9	PHS 50-1TB20
21	4,52	4,19	B	1610	1/2	1 5/8	1	3	1,5	0,9	PHS 50-1TB21
22	4,72	4,39	B	1610	1/2	1 5/8	1	3	1,6	0,9	PHS 50-1TB22
23	4,92	4,59	B	2012	3/4	2	1 1/4	3 7/16	2,0	1,7	PHS 50-1TB23
24	5,12	4,79	B	2012	3/4	2	1 1/4	3 7/16	2,2	1,7	PHS 50-1TB24
25	5,32	4,99	B	2012	3/4	2	1 1/4	3 7/16	2,4	1,7	PHS 50-1TB25
26	5,52	5,18	B	2012	3/4	2	1 1/4	3 7/16	2,5	1,7	PHS 50-1TB26
27	5,72	5,38	B	2012	3/4	2	1 1/4	3 7/16	2,6	1,7	PHS 50-1TB27
28	5,92	5,58	B	2012	3/4	2	1 1/4	3 7/16	2,8	1,7	PHS 50-1TB28
30	6,32	5,98	B	2012	3/4	2	1 1/4	3 7/16	3,2	1,7	PHS 50-1TB30
32	6,72	6,38	B	2012	3/4	2	1 1/4	3 7/16	3,6	1,7	PHS 50-1TB32
35	7,32	6,97	B	2012	3/4	2	1 1/4	3 7/16	4,2	1,7	PHS 50-1TB35
36	7,52	7,17	B	2012	3/4	2	1 1/4	3 7/16	4,3	1,7	PHS 50-1TB36
40	8,32	7,97	B	2012	3/4	2	1 1/4	3 7/16	5,2	1,7	PHS 50-1TB40
42	8,71	8,36	B	2012	3/4	2	1 1/4	3 7/16	5,9	1,7	PHS 50-1TB42
45	9,31	8,96	B	2012	3/4	2	1 1/4	3 7/16	6,5	1,7	PHS 50-1TB45
48	9,91	9,56	B	2012	3/4	2	1 1/4	3 7/16	7,3	1,7	PHS 50-1TB48
54	11,11	10,75	B	2012	3/4	2	1 1/4	3 7/16	9,0	1,7	PHS 50-1TB54
60	12,30	11,94	B	2012	3/4	2	1 1/4	3 7/16	10,8	1,7	PHS 50-1TB60
70	14,29	13,93	B	2517	3/4	2 1/2	1 3/4	4 1/4	14,0	3,5	PHS 50-1TB70
72	14,69	14,33	B	2517	3/4	2 1/2	1 3/4	4 1/4	15,5	3,5	PHS 50-1TB72
80	16,28	15,92	B	2517	3/4	2 1/2	1 3/4	4 1/4	19,5	3,5	PHS 50-1TB80
84	17,08	16,71	B	2517	3/4	2 1/2	1 3/4	4 1/4	22,5	3,5	PHS 50-1TB84
96	19,47	19,10	B	2517	3/4	2 1/2	1 3/4	4 1/4	29,0	3,5	PHS 50-1TB96
112	22,65	22,29	B	2517	3/4	2 1/2	1 3/4	4 1/4	38,7	3,5	PHS 50-1TB112

For hardened teeth sprockets, add "H" after the sprocket profile e.g. PHS 08B-1AH8.

Type B

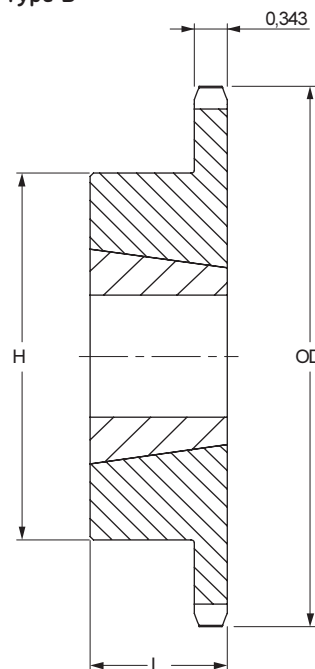



ANSI sprockets



Simplex
Taper Bushed

ANSI 60-1 3/4" Pitch

Taper Bushed Type B

No. Teeth	Diameter		Type	Bushing Size	Bore		Dimensions		Weight		Designation
	Outside	Pitch			Min	Max	L	H	Rim	Bushing	
	Inch	Inch			Inch	Inch	Inch	Inch	lbs	lbs	
11	3,00	2,66	B	1008	3/8	1	7/8	1 13/16	0,6	0,3	PHS 60-1TB11
12	3,25	2,90	B	1008	3/8	1	7/8	1 15/16	0,8	0,3	PHS 60-1TB12
13	3,49	3,13	B	1210	5/8	1 1/4	1	2 15/32	0,8	0,6	PHS 60-1TB13
14	3,74	3,37	B	1210	5/8	1 1/4	1	2 15/32	1,0	0,6	PHS 60-1TB14
15	3,98	3,61	B	1610	1/2	1 5/8	1	2 25/32	1,0	0,9	PHS 60-1TB15
16	4,22	3,84	B	1610	1/2	1 5/8	1	3	1,4	0,9	PHS 60-1TB16
17	4,46	4,08	B	1610	1/2	1 5/8	1	3 1/4	1,8	0,9	PHS 60-1TB17
18	4,70	4,32	B	1610	1/2	1 5/8	1	3 1/4	1,9	0,9	PHS 60-1TB18
19	4,95	4,56	B	1610	1/2	1 5/8	1	3 1/4	2,2	0,9	PHS 60-1TB19
20	5,18	4,79	B	2012	3/4	2	1 1/4	3 9/16	2,2	1,7	PHS 60-1TB20
21	5,43	5,03	B	2012	3/4	2	1 1/4	3 9/16	2,5	1,7	PHS 60-1TB21
22	5,67	5,27	B	2012	3/4	2	1 1/4	3 9/16	2,8	1,7	PHS 60-1TB22
23	5,91	5,51	B	2012	3/4	2	1 1/4	3 9/16	3,1	1,7	PHS 60-1TB23
24	6,15	5,75	B	2012	3/4	2	1 1/4	3 9/16	3,4	1,7	PHS 60-1TB24
25	6,39	5,98	B	2012	3/4	2	1 1/4	3 9/16	3,7	1,7	PHS 60-1TB25
26	6,63	6,22	B	2012	3/4	2	1 1/4	3 9/16	4,0	1,7	PHS 60-1TB26
27	6,87	6,42	B	2012	3/4	2	1 1/4	3 9/16	4,2	1,7	PHS 60-1TB27
28	7,11	6,70	B	2012	3/4	2	1 1/4	3 9/16	4,6	1,7	PHS 60-1TB28
30	7,59	7,17	B	2012	3/4	2	1 1/4	3 9/16	5,2	1,7	PHS 60-1TB30
32	8,06	7,65	B	2012	3/4	2	1 1/4	3 9/16	5,6	1,7	PHS 60-1TB32
35	8,78	8,37	B	2012	3/4	2	1 1/4	3 9/16	6,4	1,7	PHS 60-1TB35
36	9,02	8,61	B	2012	3/4	2	1 1/4	3 9/16	6,6	1,7	PHS 60-1TB36
40	9,98	9,56	B	2012	3/4	2	1 1/4	3 9/16	8,3	1,7	PHS 60-1TB40
42	10,46	10,04	B	2012	3/4	2	1 1/4	3 9/16	10,0	1,7	PHS 60-1TB42
45	11,18	10,75	B	2012	3/4	2	1 1/4	3 9/16	11,5	1,7	PHS 60-1TB45
48	11,89	11,47	B	2012	3/4	2	1 1/4	3 9/16	13,2	1,7	PHS 60-1TB48
54	13,33	12,90	B	2517	3/4	2 1/2	1 3/4	4 1/4	17,1	3,5	PHS 60-1TB54
60	14,76	14,33	B	2517	3/4	2 1/2	1 3/4	4 1/4	21,0	3,5	PHS 60-1TB60
70	17,15	16,72	B	2517	3/4	2 1/2	1 3/4	4 1/4	27,6	3,5	PHS 60-1TB70
72	17,63	17,19	B	2517	3/4	2 1/2	1 3/4	4 1/4	30,0	3,5	PHS 60-1TB72
80	19,54	19,10	B	2517	3/4	2 1/2	1 3/4	4 1/4	36,3	3,5	PHS 60-1TB80
84	20,49	20,06	B	2517	3/4	2 1/2	1 3/4	4 1/4	40,6	3,5	PHS 60-1TB84

For hardened teeth sprockets, add "H" after the sprocket profile e.g. PHS 08B-1AH8.

Type B

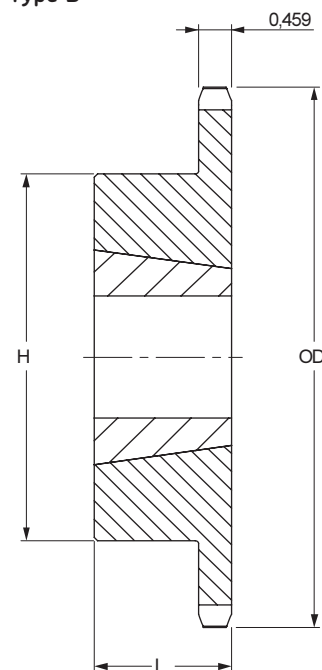

ANSI 80-1 1" Pitch

Taper Bushed Type B

No. Teeth	Diameter		Type	Bushing Size	Bore		Dimensions		Weight		Designation
	Outside	Pitch			Min	Max	L	H	Rim	Bushing	
	Inch	Inch			Inch	Inch	Inch	Inch	lbs	lbs	
10	3,68	3,24	B	1215	5/8	1 1/4	1 1/2	2 3/8	1,1	0,8	PHS 80-1TB10
11	4,01	3,55	B	1215	5/8	1 1/4	1 1/2	2 15/32	1,5	0,8	PHS 80-1TB11
12	4,33	3,86	B	1615	1/2	1 5/8	1 1/2	3	1,8	1,2	PHS 80-1TB12
13	4,66	4,18	B	1615	1/2	1 5/8	1 1/2	3	2,3	1,2	PHS 80-1TB13
14	4,98	4,49	B	1615	1/2	1 5/8	1 1/2	3 1/4	2,5	1,2	PHS 80-1TB14
15	5,30	4,81	B	1615	1/2	1 5/8	1 1/2	3 1/4	2,7	1,2	PHS 80-1TB15
16	5,63	5,13	B	2012	3/4	2	1 1/4	3 9/16	2,8	1,7	PHS 80-1TB16
17	5,95	5,44	B	2012	3/4	2	1 1/4	3 9/16	3,1	1,7	PHS 80-1TB17
18	6,27	5,76	B	2012	3/4	2	1 1/4	3 9/16	2,6	1,7	PHS 80-1TB18
19	6,59	6,08	B	2012	3/4	2	1 1/4	3 9/16	4,1	1,7	PHS 80-1TB19
20	6,91	6,39	B	2517	3/4	2 1/2	1 3/4	4 1/4	5,5	1,7	PHS 80-1TB20
21	7,24	6,71	B	2517	3/4	2 1/2	1 3/4	4 1/4	6,0	3,5	PHS 80-1TB21
22	7,55	7,03	B	2517	3/4	2 1/2	1 3/4	4 1/4	6,5	3,5	PHS 80-1TB22
23	7,88	7,34	B	2517	3/4	2 1/2	1 3/4	4 1/4	7,0	3,5	PHS 80-1TB23
24	8,20	7,66	B	2517	3/4	2 1/2	1 3/4	4 1/4	7,5	3,5	PHS 80-1TB24
25	8,52	7,98	B	2517	3/4	2 1/2	1 3/4	4 1/4	8,1	3,5	PHS 80-1TB25
26	8,84	8,30	B	2517	3/4	2 1/2	1 3/4	4 1/4	8,8	3,5	PHS 80-1TB26
27	9,16	8,61	B	2517	3/4	2 1/2	1 3/4	4 1/4	9,0	3,5	PHS 80-1TB27
28	9,47	8,93	B	2517	3/4	2 1/2	1 3/4	4 1/4	9,5	3,5	PHS 80-1TB28
30	10,11	9,57	B	2517	3/4	2 1/2	1 3/4	4 1/4	11,5	3,5	PHS 80-1TB30
32	10,75	10,20	B	2517	3/4	2 1/2	1 3/4	4 1/4	12,0	3,5	PHS 80-1TB32
35	11,71	11,16	B	2517	3/4	2 1/2	1 3/4	4 1/4	15,2	3,5	PHS 80-1TB35
36	12,03	11,47	B	2517	3/4	2 1/2	1 3/4	4 1/4	17,0	3,5	PHS 80-1TB36
40	13,31	12,75	B	2517	3/4	2 1/2	1 3/4	4 1/4	21,0	3,5	PHS 80-1TB40
45	14,90	14,34	B	2517	3/4	2 1/2	1 3/4	4 1/4	26,5	3,5	PHS 80-1TB45
48	15,86	15,29	B	2517	3/4	2 1/2	1 3/4	4 1/4	29,5	3,5	PHS 80-1TB48
54	17,77	17,20	B	2517	3/4	2 1/2	1 3/4	4 1/4	38,5	3,5	PHS 80-1TB54
60	19,68	19,11	B	2517	3/4	2 1/2	1 3/4	4 1/4	45,0	3,5	PHS 80-1TB60
70	22,87	22,29	B	3020	1 1/4	3	2	5 1/4	52,3	6,5	PHS 80-1TB70
80	26,05	25,47	B	3020	1 1/4	3	2	5 1/4	69,2	6,5	PHS 80-1TB80

For hardened teeth sprockets, add "H" after the sprocket profile e.g. PHS 08B-1AH8.

Type B

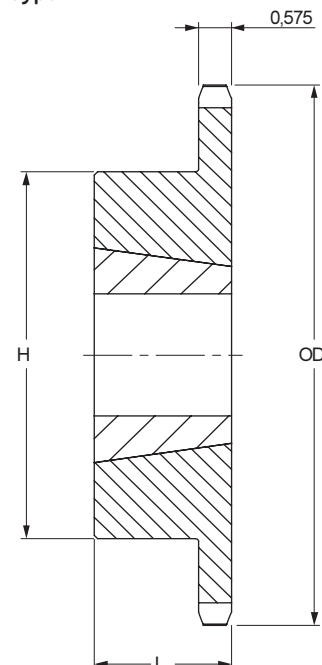



ANSI sprockets

Simplex

Taper Bushed

- ▶ Belts
- ▶ Chains
- ▶ Couplings
- ▶ Bushings and Hubs
- ▶ Sprockets
- ▶ Pulleys
- ▶ Smart tools

ANSI 100-1 1 1/4" Pitch

Taper Bushed Type B

No. Teeth	Diameter		Type	Bushing Size	Bore		Dimensions		Weight		Designation
	Outside	Pitch			Min	Max	L	H	Rim	Bushing	
11	5,01	4,44	B	1615	1/2	1 1/8	1 1/2	3	2,7	1,2	PHS 100-1TB11
12	5,42	4,83	B	1615	1/2	1 1/8	1 1/2	3 1/4	3,5	1,2	PHS 100-1TB12
13	5,82	5,22	B	2012	3/4	2	1 1/4	3 1/16	3,6	1,7	PHS 100-1TB13
14	6,23	5,62	B	2012	3/4	2	1 1/4	3 1/16	3,9	1,7	PHS 100-1TB14
15	6,63	6,01	B	2517	3/4	2 1/2	1 3/4	4 1/4	5,0	3,5	PHS 100-1TB15
16	7,03	6,41	B	2517	3/4	2 1/2	1 3/4	4 1/2	6,4	3,5	PHS 100-1TB16
17	7,44	6,80	B	2517	3/4	2 1/2	1 3/4	4 1/2	7,1	3,5	PHS 100-1TB17
18	7,84	7,20	B	2517	3/4	2 1/2	1 3/4	4 1/2	7,8	3,5	PHS 100-1TB18
19	8,24	7,59	B	2517	3/4	2 1/2	1 3/4	4 1/2	8,7	3,5	PHS 100-1TB19
20	8,64	7,99	B	2517	3/4	2 1/2	1 3/4	4 1/2	9,6	3,5	PHS 100-1TB20
21	9,04	8,39	B	2517	3/4	2 1/2	1 3/4	4 1/2	10,6	3,5	PHS 100-1TB21
22	9,44	8,78	B	2517	3/4	2 1/2	1 3/4	4 1/2	11,0	3,5	PHS 100-1TB22
24	10,24	9,58	B	2517	3/4	2 1/2	1 3/4	4 1/2	13,0	3,5	PHS 100-1TB24
26	11,04	10,37	B	2517	3/4	2 1/2	1 3/4	4 1/2	15,0	3,5	PHS 100-1TB26
28	11,84	11,16	B	3020	1 1/4	3	2	5 1/4	16,5	6,5	PHS 100-1TB28
30	12,64	11,96	B	3020	1 1/4	3	2	5 1/4	22,0	6,5	PHS 100-1TB30
32	13,44	12,75	B	3020	1 1/4	3	2	5 1/4	23,0	6,5	PHS 100-1TB32
35	14,64	13,95	B	3020	1 1/4	3	2	5 1/4	28,0	6,5	PHS 100-1TB35
36	15,04	14,34	B	3020	1 1/4	3	2	5 1/4	31,0	6,5	PHS 100-1TB36
40	16,63	15,93	B	3020	1 1/4	3	2	5 1/4	37,0	6,5	PHS 100-1TB40
45	18,63	17,92	B	3020	1 1/4	3	2	5 1/4	46,0	6,5	PHS 100-1TB45
48	19,82	19,11	B	3020	1 1/4	3	2	5 1/4	53,0	6,5	PHS 100-1TB48
54	22,21	21,50	B	3020	1 1/4	3	2	5 1/4	62,0	6,5	PHS 100-1TB54
60	24,60	23,88	B	3020	1 1/4	3	2	5 1/4	72,0	6,5	PHS 100-1TB60

For hardened teeth sprockets, add "H" after the sprocket profile e.g. PHS 08B-1AH8.

Type B

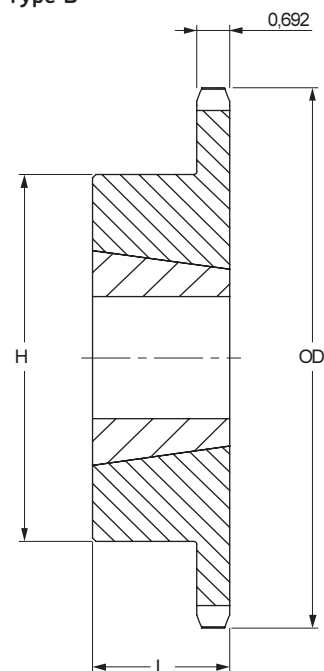

ANSI 120-1 1 1/2" Pitch

Taper Bushed Type B/C

No. Teeth	Diameter		Type	Bushing Size	Bore		Dimensions		Weight		Designation
	Outside	Pitch			Min	Max	L	H	Rim	Bushing	
12	6,50	5,80	B	2012	3/4	2	1 1/4	3 1/16	5,5	1,7	PHS 120-1TB12
13	6,90	6,27	B	2517	3/4	2 1/2	1 3/4	4 1/4	6,0	3,5	PHS 120-1TB13
14	7,47	6,74	B	2517	3/4	2 1/2	1 3/4	4 1/4	7,0	3,5	PHS 120-1TB14
15	7,96	7,21	B	2517	3/4	2 1/2	1 3/4	4 1/4	8,0	3,5	PHS 120-1TB15
16	8,44	7,69	B	3020	1 1/4	3	2	5 1/4	10,0	6,5	PHS 120-1TB16
17	8,92	8,16	B	3020	1 1/4	3	2	5 1/4	11,0	6,5	PHS 120-1TB17
18	9,41	8,64	B	3020	1 1/4	3	2	5 1/4	12,0	6,5	PHS 120-1TB18
19	9,89	9,11	B	3020	1 1/4	3	2	5 1/4	14,0	6,5	PHS 120-1TB19
20	10,37	9,59	B	3020	1 1/4	3	2	5 1/4	15,5	6,5	PHS 120-1TB20
21	10,85	10,06	B	3020	1 1/4	3	2	5 1/4	17,5	6,5	PHS 120-1TB21
24	12,29	11,49	B	3020	1 1/4	3	2	5 1/4	23,5	6,5	PHS 120-1TB24
26	13,25	12,44	B	3020	1 1/4	3	2	5 1/4	28,5	6,5	PHS 120-1TB26
30	15,17	14,35	B	3020	1 1/4	3	2	5 1/4	33,5	6,5	PHS 120-1TB30
35	17,57	16,73	C	3020	1 1/4	3	2	5 1/4	52,0	6,5	PHS 120-1TB35
45	22,35	21,50	C	3030	1 1/4	3	3	5 7/8	82,0	9,2	PHS 120-1TB45
60	29,52	28,66	C	3535	1 1/2	3 1/2	3 1/2	6 1/2	140,0	14,0	PHS 120-1TB60
70	34,30	33,43	C	3535	1 1/2	3 1/2	3 1/2	6 1/2	175,0	14,0	PHS 120-1TB70
80	39,08	38,21	C	3535	1 1/2	3 1/4	3 1/2	6 1/2	220,0	14,0	PHS 120-1TB80

For hardened teeth sprockets, add "H" after the sprocket profile e.g. PHS 08B-1AH8.

Type B

Type C

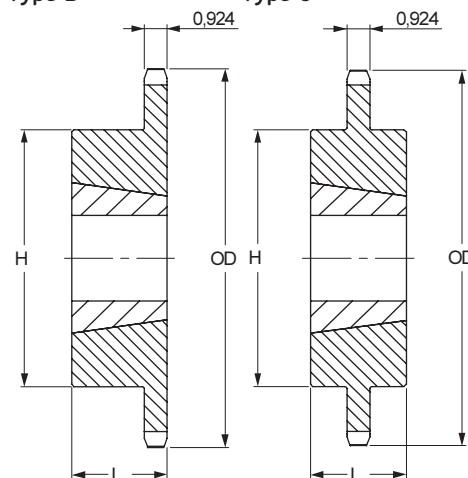



ANSI sprockets



Simplex
Taper Bushed

ANSI 140-1 1 3/4" Pitch

Taper Bushed Type B/C

No. Teeth	Diameter		Type	Bushing Size	Bore		Dimensions		Weight		Designation
	Outside	Pitch			Min	Max	L	H	Rim	Bushing	
	Inch	Inch			Inch	Inch	Inch	Inch	lbs	lbs	
12	7,58	6,76	B	2517	3/4	2 1/2	1 3/4	4 1/4	7,0	3,5	PHS 140-1TB12
13	8,15	7,31	B	3020	1 1/4	3	2	5 1/4	8,0	6,5	PHS 140-1TB13
14	8,72	7,86	B	3020	1 1/4	3	2	5 1/4	10,0	6,5	PHS 140-1TB14
15	9,28	8,42	B	3020	1 1/4	3	2	5 1/4	12,0	6,5	PHS 140-1TB15
16	9,85	8,97	B	3020	1 1/4	3	2	5 1/4	14,0	6,5	PHS 140-1TB16
17	10,41	9,52	B	3020	1 1/4	3	2	5 1/4	16,0	6,5	PHS 140-1TB17
18	10,97	10,08	B	3020	1 1/4	3	2	5 1/4	18,0	6,5	PHS 140-1TB18
19	11,54	10,63	B	3020	1 1/4	3	2	5 1/4	20,0	6,5	PHS 140-1TB19
21	12,66	11,74	B	3020	1 1/4	3	2	5 1/4	24,0	6,5	PHS 140-1TB21
26	15,46	14,52	B	3020	1 1/4	3	2	5 1/4	40,0	6,5	PHS 140-1TB26
35	20,49	19,52	C	3535	1 1/2	3 1/2	3 1/2	6 1/2	78,0	14,0	PHS 140-1TB35
45	26,08	25,09	C	4040	1 3/4	4	4	7 3/4	118,0	22,0	PHS 140-1TB45
60	34,44	33,44	C	4040	1 3/4	4	4	7 3/4	188,0	22,0	PHS 140-1TB60
70	40,02	39,01	C	4040	1 3/4	4	4	7 3/4	241,0	22,0	PHS 140-1TB70

For hardened teeth sprockets, add "H" after the sprocket profile e.g. PHS 08B-1AH8.

Type B

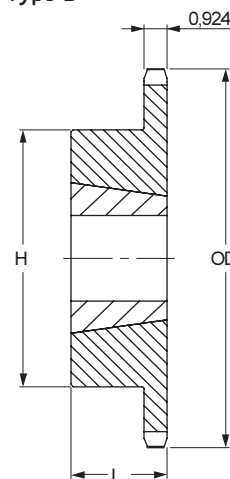

Type C

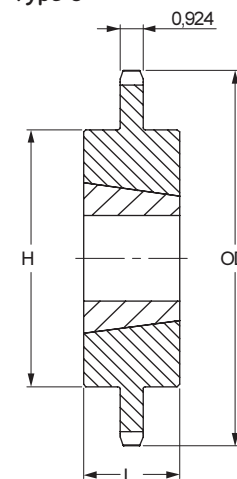

ANSI 160-1 2" Pitch

Taper Bushed Type B/C

No. Teeth	Diameter		Type	Bushing Size	Bore		Dimensions		Weight		Designation
	Outside	Pitch			Min	Max	L	H	Rim	Bushing	
	Inch	Inch			Inch	Inch	Inch	Inch	lbs	lbs	
11	8,01	7,10	B	2517	3/4	2 1/2	1 3/4	4 1/4	9,0	3,5	PHS 160-1TB11
12	8,66	7,73	B	3020	1 1/4	3	2	5 1/4	11,0	6,5	PHS 160-1TB12
13	9,31	8,36	B	3020	1 1/4	3	2	5 1/4	13,0	6,5	PHS 160-1TB13
14	9,96	8,99	B	3020	1 1/4	3	2	5 1/4	16,0	6,5	PHS 160-1TB14
15	10,61	9,62	B	3535	1 1/2	3 1/2	3 1/2	6 1/2	25,0	14,0	PHS 160-1TB15
16	11,26	10,25	B	3535	1 1/2	3 1/2	3 1/2	6 1/2	28,0	14,0	PHS 160-1TB16
17	11,90	10,88	B	3535	1 1/2	3 1/2	3 1/2	6 1/2	32,0	14,0	PHS 160-1TB17
18	12,54	11,52	B	3535	1 1/2	3 1/2	3 1/2	6 1/2	35,0	14,0	PHS 160-1TB18
19	13,19	12,15	B	3535	1 1/2	3 1/2	3 1/2	6 1/2	39,0	14,0	PHS 160-1TB19
21	14,47	13,42	B	3535	1 1/2	3 1/2	3 1/2	6 1/2	48,0	14,0	PHS 160-1TB21
26	17,67	16,59	B	3535	1 1/2	3 1/2	3 1/2	6 1/2	68,0	14,0	PHS 160-1TB26
35	23,42	22,31	C	4040	1 3/4	4	4	7 3/4	118,0	14,0	PHS 160-1TB35
45	29,80	28,67	C	4040	1 3/4	4	4	7 3/4	186,0	22,0	PHS 160-1TB45
60	39,36	38,22	C	4545	2 1/8	4 1/2	4 1/2	7 3/4	292,0	30,0	PHS 160-1TB60

For hardened teeth sprockets, add "H" after the sprocket profile e.g. PHS 08B-1AH8.

Type B

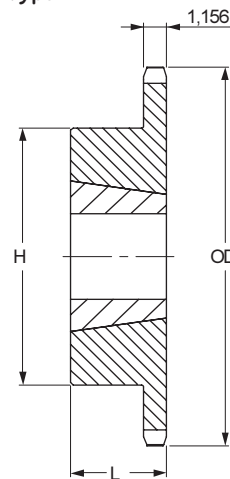

Type C

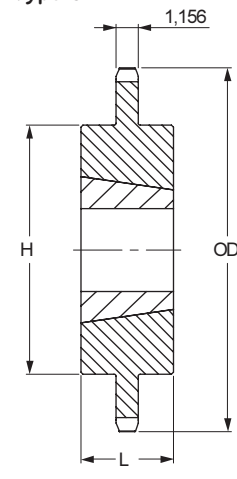

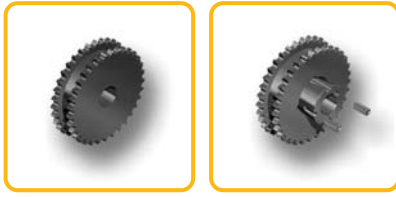

ANSI sprockets

Double Simplex

- ▶ Belts
- ▶ Chains
- ▶ Couplings
- ▶ Bushings and Hubs
- ▶ Sprockets
- ▶ Pulleys
- ▶ Smart tools

ANSI 40-1 1/2" Pitch

Double Simplex Type A

No. Teeth	Diameter		Type	Bore		Dimensions			Weight lbs	Designation
	Outside	Pitch		Min	Max	L	C	E		
15	2,65	2,40	A	1/2	1 1/4	1 13/32	1 1/8	1 13/16	1,2	PHS 40-1DSA15
16	2,81	2,56	A	1/2	1 1/4	1 13/32	1 1/8	2	1,4	PHS 40-1DSA16
17	2,98	2,72	A	1/2	1 5/16	1 13/32	1 1/8	2 1/8	1,6	PHS 40-1DSA17
18	3,14	2,88	A	1/2	1 1/2	1 13/32	1 1/8	2 5/16	1,8	PHS 40-1DSA18
19	3,30	3,04	A	5/8	1 11/16	1 13/32	1 1/8	2 1/2	2,2	PHS 40-1DSA19
20	3,46	3,20	A	5/8	1 3/4	1 13/32	1 1/8	2 5/8	2,6	PHS 40-1DSA20
21	3,62	3,36	A	5/8	1 3/4	1 13/32	1 1/8	2 25/32	2,9	PHS 40-1DSA21
22	3,78	3,51	A	5/8	1 13/16	1 13/32	1 1/8	2 15/16	3,0	PHS 40-1DSA22
23	3,94	3,67	A	5/8	2 1/16	1 13/32	1 1/8	2 3/32	3,5	PHS 40-1DSA23
24	4,10	3,83	A	5/8	2 1/4	1 13/32	1 1/8	2 17/64	4,0	PHS 40-1DSA24
25	4,26	3,99	A	5/8	2 1/4	1 13/32	1 1/8	2 7/16	4,5	PHS 40-1DSA25

For hardened teeth sprockets, add "H" after the sprocket profile e.g. PHS 08B-1AH8.

Type A

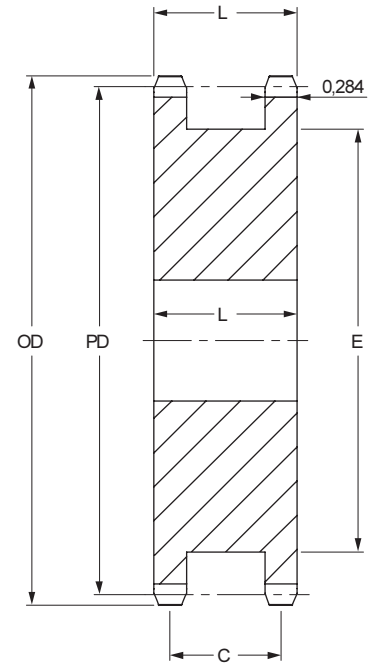

Double Simplex Taper Bushed Type A

No. Teeth	Bushing Size	Diameters		Type	Bore		Dimensions				Weight* lbs	Designation
		Outside	Pitch		Min	Max	L ₁	C	E	L ₂		
18	1215	3,14	2,88	A	1/2	1 1/4	1 13/32	1 1/8	2 5/16	1 1/2	1,0	PHS 40-1DSTB18
19	1215	3,30	3,04	A	1/2	1 1/4	1 13/32	1 1/8	2 1/2	1 1/2	1,1	PHS 40-1DSTB19
20	1215	3,46	3,20	A	1/2	1 1/4	1 13/32	1 1/8	2 5/8	1 1/2	1,3	PHS 40-1DSTB20
21	1615	3,62	3,36	A	1/2	1 5/8	1 13/32	1 1/8	2 25/32	1 1/2	1,3	PHS 40-1DSTB21
23	1615	3,94	3,67	A	1/2	1 5/8	1 13/32	1 1/8	3 3/32	1 1/2	1,5	PHS 40-1DSTB23
24	1615	4,10	3,83	A	1/2	1 5/8	1 13/32	1 1/8	3 17/64	1 1/2	1,7	PHS 40-1DSTB24

* Weight for rim only

For hardened teeth sprockets, add "H" after the sprocket profile e.g. PHS 08B-1AH8.

Type A Taper Bush

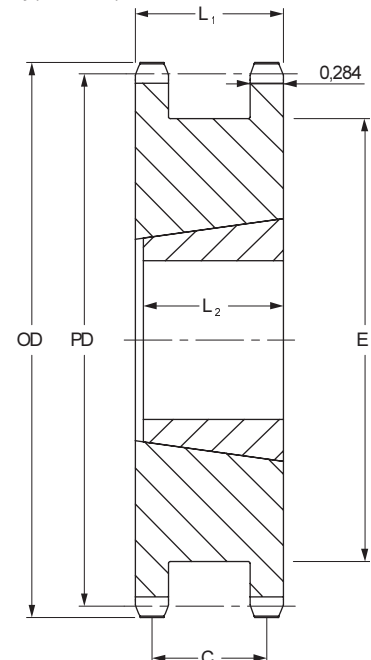



ANSI sprockets

Double Simplex



ANSI 50-1 5/8" Pitch

Double Simplex Type A

No. Teeth	Diameter		Type	Bore		Dimensions			Weight	Designation
	Outside	Pitch		Min	Max	L	C	E		
15	3,32	3,01	A	$\frac{5}{8}$	$1\frac{1}{2}$	$1\frac{21}{32}$	$1\frac{3}{16}$	$2\frac{3}{8}$	2,1	PHS 50-1DSA15
16	3,52	3,20	A	$\frac{5}{8}$	$1\frac{11}{16}$	$1\frac{21}{32}$	$1\frac{7}{16}$	$2\frac{1}{2}$	2,4	PHS 50-1DSA16
17	3,72	3,40	A	$\frac{5}{8}$	$1\frac{3}{4}$	$1\frac{21}{32}$	$1\frac{7}{16}$	$2\frac{11}{16}$	2,9	PHS 50-1DSA17
18	3,92	3,60	A	$\frac{5}{8}$	$1\frac{7}{8}$	$1\frac{21}{32}$	$1\frac{5}{16}$	$2\frac{57}{64}$	3,3	PHS 50-1DSA18
19	4,12	3,80	A	$\frac{5}{8}$	$2\frac{1}{16}$	$1\frac{21}{32}$	$1\frac{5}{16}$	$3\frac{9}{64}$	3,7	PHS 50-1DSA19
20	4,32	4,00	A	$\frac{5}{8}$	$2\frac{1}{4}$	$1\frac{21}{32}$	$1\frac{5}{16}$	$3\frac{9}{32}$	4,2	PHS 50-1DSA20
21	4,52	4,19	A	$\frac{5}{8}$	$2\frac{3}{4}$	$1\frac{21}{32}$	$1\frac{5}{16}$	$3\frac{31}{64}$	4,8	PHS 50-1DSA21
22	4,72	4,39	A	$\frac{5}{8}$	$2\frac{7}{16}$	$1\frac{21}{32}$	$1\frac{5}{16}$	$3\frac{11}{16}$	5,3	PHS 50-1DSA22
23	4,92	4,59	A	$\frac{5}{8}$	$2\frac{5}{8}$	$1\frac{21}{32}$	$1\frac{5}{16}$	$3\frac{57}{64}$	5,8	PHS 50-1DSA23
24	5,12	4,79	A	$\frac{5}{8}$	$2\frac{3}{4}$	$1\frac{21}{32}$	$1\frac{5}{16}$	$4\frac{5}{64}$	6,3	PHS 50-1DSA24

For hardened teeth sprockets, add "H" after the sprocket profile e.g. PHS 08B-1AH8.

Type A

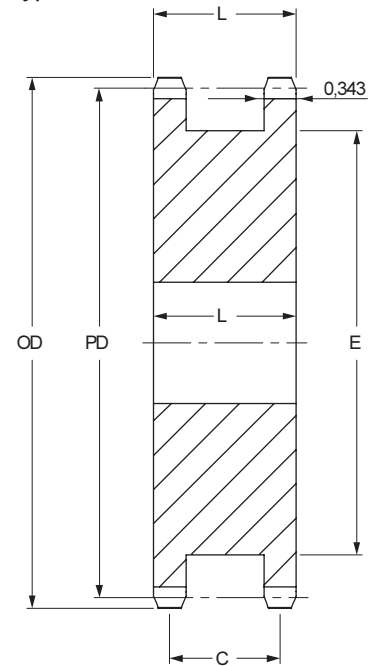

Double Simplex Taper Bushed Type A

No. Teeth	Bushing Size	Diameters		Type	Bore		Dimensions					Weight*	Designation
		Pitch	Min		Max	L ₁	C	E	L ₂	Inch			
											Inch		
16	1215	3,52	3,20	A	$\frac{1}{2}$	$1\frac{5}{8}$	$1\frac{21}{32}$	$1\frac{5}{16}$	$2\frac{31}{64}$	$1\frac{1}{2}$	3,0	PHS 50-1DSTB16	
17	1615	3,72	3,40	A	$\frac{1}{2}$	$1\frac{5}{8}$	$1\frac{21}{32}$	$1\frac{5}{16}$	$2\frac{11}{16}$	$1\frac{1}{2}$	1,8	PHS 50-1DSTB17	
18	1615	3,92	3,60	A	$\frac{1}{2}$	$1\frac{5}{8}$	$1\frac{21}{32}$	$1\frac{5}{16}$	$2\frac{57}{64}$	$1\frac{1}{2}$	2,2	PHS 50-1DSTB18	
19	1615	4,12	3,80	A	$\frac{1}{2}$	$1\frac{5}{8}$	$1\frac{21}{32}$	$1\frac{5}{16}$	$3\frac{9}{64}$	$1\frac{1}{2}$	2,7	PHS 50-1DSTB19	
20	1615	4,32	4,00	A	$\frac{1}{2}$	$1\frac{5}{8}$	$1\frac{21}{32}$	$1\frac{5}{16}$	$3\frac{9}{32}$	$1\frac{1}{2}$	5,0	PHS 50-1DSTB20	
21	2012	4,52	4,19	A	$\frac{1}{2}$	2	$1\frac{21}{32}$	$1\frac{5}{16}$	$3\frac{31}{64}$	$1\frac{3}{4}$	3,3	PHS 50-1DSTB21	
23	2012	4,92	4,59	A	$\frac{1}{2}$	2	$1\frac{21}{32}$	$1\frac{5}{16}$	$3\frac{57}{64}$	$1\frac{3}{4}$	3,7	PHS 50-1DSTB23	
24	2012	5,12	4,79	A	$\frac{1}{2}$	2	$1\frac{21}{32}$	$1\frac{5}{16}$	$4\frac{5}{64}$	$1\frac{3}{4}$	4,1	PHS 50-1DSTB24	

* Weight for rim only

For hardened teeth sprockets, add "H" after the sprocket profile e.g. PHS 08B-1AH8.

Type A Taper Bush

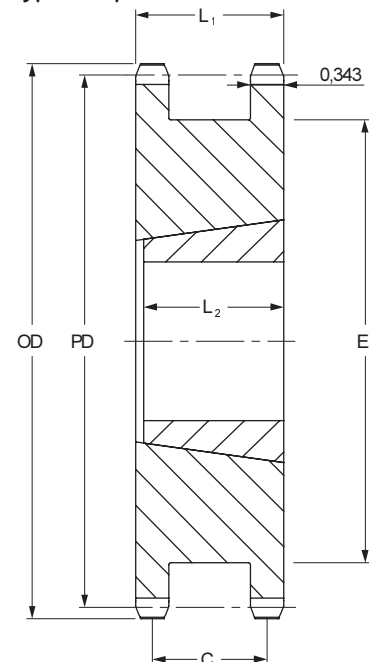



ANSI sprockets

Double Simplex

- ▶ Belts
- ▶ Chains
- ▶ Couplings
- ▶ Bushings and Hubs
- ▶ Sprockets
- ▶ Pulleys
- ▶ Smart tools

ANSI 60-1 3/4" Pitch

Double Simplex Type A

No. Teeth	Diameter		Type	Bore		Dimensions			Weight lbs	Designation
	Outside	Pitch		Min	Max	L	C	E		
13	3,49	3,13	A	3/4	1 1/4	1 15/16	1 31/64	2 11/32	2,6	PHS 60-1DSA13
14	3,74	3,37	A	3/4	1 5/16	1 15/16	1 31/64	2 7/16	3,2	PHS 60-1DSA14
15	3,98	3,61	A	3/4	1 1/2	1 15/16	1 31/64	2 7/8	3,8	PHS 60-1DSA15
16	4,22	3,84	A	3/4	1 11/16	1 15/16	1 31/64	3 3/64	4,5	PHS 60-1DSA16
17	4,46	4,08	A	3/4	1 3/4	1 15/16	1 31/64	3 1/4	5,3	PHS 60-1DSA17
18	4,70	4,32	A	3/4	1 7/8	1 15/16	1 31/64	3 1/2	6,5	PHS 60-1DSA18
19	4,95	4,56	A	3/4	2 1/16	1 15/16	1 31/64	3 45/64	6,8	PHS 60-1DSA19
20	5,19	4,79	A	3/4	2 1/4	1 15/16	1 31/64	3 63/64	7,0	PHS 60-1DSA20
21	5,43	5,03	A	3/4	2 3/4	1 15/16	1 31/64	4 3/16	7,5	PHS 60-1DSA21
22	5,67	5,27	A	3/4	2 3/4	1 15/16	1 31/64	4 7/16	11,0	PHS 60-1DSA22
23	5,91	5,51	A	3/4	2 3/4	1 15/16	1 31/64	4 21/32	11,5	PHS 60-1DSA23
24	6,15	5,75	A	3/4	2 3/4	1 15/16	1 31/64	4 38/32	12,0	PHS 60-1DSA24

For hardened teeth sprockets, add "H" after the sprocket profile e.g. PHS 08B-1AH8.

Type A

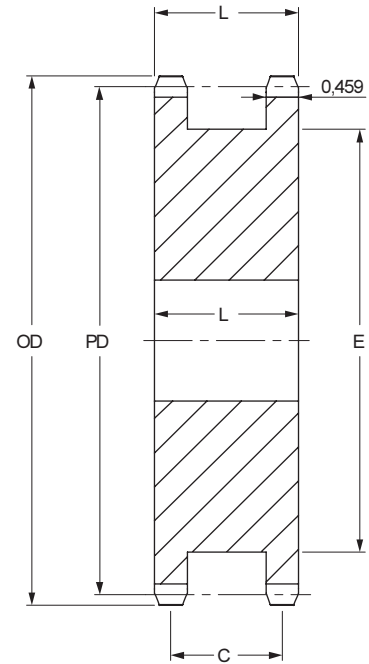

Double Simplex Taper Bushed Type A

No. Teeth	Bushing Size	Diameters		Type	Bore		Dimensions				Weight*	Designation
		Outside	Pitch		Min	Max	L ₁	C	E	L ₂		
16	1615	4,22	3,84	A	1/2	1 5/8	1 15/16	1 31/64	2 63/64	1 1/2	4,5	PHS 60-1DSTB16
17	1615	4,46	4,00	A	1/2	1 5/8	1 15/16	1 31/64	3 7/32	1 3/2	4,5	PHS 60-1DSTB17
18	2012	4,70	4,32	A	1/2	2	1 15/16	1 31/64	3 25/32	1 1/4	5,0	PHS 60-1DSTB18
19	2012	4,95	4,56	A	1/2	2	1 15/16	1 31/64	3 45/64	1 1/4	5,8	PHS 60-1DSTB19
20	2517	5,19	4,79	A	1/2	2 1/2	1 15/16	1 31/64	3 61/64	1 3/4	5,6	PHS 60-1DSTB20
21	2517	5,43	5,03	A	1/2	2 1/2	1 15/16	1 31/64	4 3/16	1 3/4	6,4	PHS 60-1DSTB21
23	2517	5,91	5,51	A	1/2	2 1/2	1 15/16	1 31/64	4 43/64	1 3/4	7,3	PHS 60-1DSTB23
24	2517	6,15	5,75	A	1/2	2 1/2	1 15/16	1 31/64	4 38/32	1 3/4	8,2	PHS 60-1DSTB24

* Weight for rim only

For hardened teeth sprockets, add "H" after the sprocket profile e.g. PHS 08B-1AH8.

Type A Taper Bush

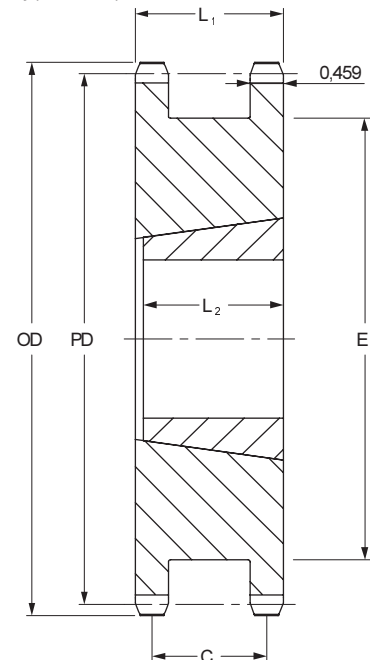



ANSI sprockets

Double Simplex



ANSI 80-1 1" Pitch

Double Simplex Type A

No. Teeth	Diameter		Type	Bore		Dimensions			Weight	Designation
	Outside	Pitch		Min	Max	L	C	E		
	Inch	Inch		Inch	Inch	Inch	Inch	Inch		
13	4,66	4,18	A	1	2	2 3/16	1 5/8	3 1/64	6,5	PHS 80-1DSA13
14	4,98	4,49	A	1	2 1/4	2 3/16	1 5/8	3 13/32	7,7	PHS 80-1DSA14
15	5,30	4,81	A	1	2 5/8	2 3/16	1 5/8	3 13/16	9,1	PHS 80-1DSA15
16	5,63	5,13	A	1	2 13/16	2 3/16	1 5/8	4	9,5	PHS 80-1DSA16
17	5,95	5,44	A	1	2 13/16	2 3/16	1 5/8	4 5/16	10,8	PHS 80-1DSA17
18	6,27	5,76	A	1	3 1/8	2 3/16	1 5/8	4 43/64	12,1	PHS 80-1DSA18
19	6,59	6,08	A	1	3 1/4	2 3/16	1 5/8	4 61/64	12,8	PHS 80-1DSA19
20	6,91	6,39	A	1	3 1/2	2 3/16	1 5/8	5 9/32	14,0	PHS 80-1DSA20
21	7,24	6,71	A	1	3 3/4	2 3/16	1 5/8	5 19/32	16,5	PHS 80-1DSA21
22	7,56	7,03	A	1	3 7/8	2 3/16	1 5/8	5 59/64	18,4	PHS 80-1DSA22
23	7,88	7,34	A	1	3 7/8	2 3/16	1 5/8	6 15/64	20,5	PHS 80-1DSA23

For hardened teeth sprockets, add "H" after the sprocket profile e.g. PHS 08B-1AH8.

Type A

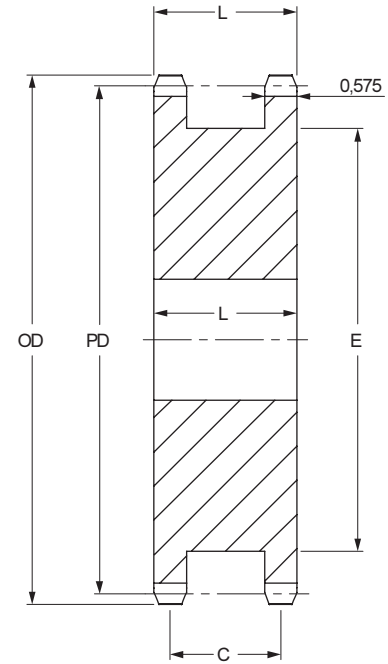

Double Simplex Taper Bushed Type A

No. Teeth	Bushing Size	Diameters		Type	Bore		Dimensions				Weight*	Designation
		Outside	Pitch		Min	Max	L ₁	C	E	L ₂		
		Inch	Inch		Inch	Inch	Inch	Inch	Inch	Inch		
17	2517	5,95	5,44	A	1 1/2	2 1/2	2 3/16	1 5/8	4 5/16	1 3/4	7,6	PHS 80-1DSTB17
18	2517	6,27	5,76	A	1 1/2	2 3/2	2 3/16	1 5/8	4 3/4	1 3/4	8,7	PHS 80-1DSTB18
19	3020	6,59	6,08	A	1 5/16	3	2 3/16	1 5/8	4 61/64	2	9,7	PHS 80-1DSTB19
20	3020	6,91	6,39	A	1 5/16	3	2 3/16	1 5/8	5 9/32	2	10,0	PHS 80-1DSTB20
21	3020	7,24	6,71	A	1 5/16	3	2 3/16	1 5/8	5 19/32	2	12,0	PHS 80-1DSTB21
22	3020	7,56	7,03	A	1 5/16	3	2 3/16	1 5/8	5 19/32	2	13,0	PHS 80-1DSTB22
23	3020	7,88	7,34	A	1 5/16	3	2 3/16	1 5/8	6 15/64	2	14,5	PHS 80-1DSTB23

* Weight for rim only

For hardened teeth sprockets, add "H" after the sprocket profile e.g. PHS 08B-1AH8.

Type A Taper Bush

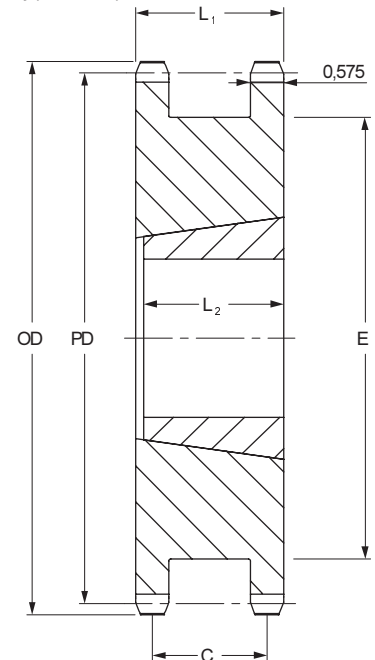



ANSI sprockets

Double Simplex

- ▶ Belts
- ▶ Chains
- ▶ Couplings
- ▶ Bushings and Hubs
- ▶ Sprockets
- ▶ Pulleys
- ▶ Smart tools

ANSI 100-1 1 1/4" Pitch

Double Simplex Type A

No. Teeth	Diameter		Type	Bore		Dimensions			Weight lbs	Designation
	Outside	Pitch		Min	Max	L	C	E		
	Inch	Inch		Inch	Inch	Inch	Inch	Inch		
13	5,82	5,22	A	1	2 1/2	2 11/16	2	3 25/32	11,2	PHS 100-1DSA13
14	6,23	5,62	A	1 1/4	2 3/4	2 11/16	2	4 3/16	13,5	PHS 100-1DSA14
15	6,63	6,01	A	1 1/4	3 1/16	2 11/16	2	4 19/32	16,8	PHS 100-1DSA15
16	7,03	6,41	A	1 1/4	3 1/4	2 11/16	2	5	19,3	PHS 100-1DSA16
17	7,44	6,80	A	1 1/4	3 5/8	2 11/16	2	5 13/32	21,5	PHS 100-1DSA17
18	7,84	7,20	A	1 1/4	3 3/4	2 11/16	2	5 53/64	23,0	PHS 100-1DSA18
19	8,24	7,59	A	1 1/4	4 3/16	2 11/16	2	6 13/64	25,0	PHS 100-1DSA19
20	8,64	7,99	A	1 1/4	4 3/8	2 11/16	2	6 39/64	26,5	PHS 100-1DSA20
21	9,04	8,39	A	1 1/4	5 1/4	2 11/16	2	7	29,0	PHS 100-1DSA21

For hardened teeth sprockets, add "H" after the sprocket profile e.g. PHS 08B-1AH8.

Type A

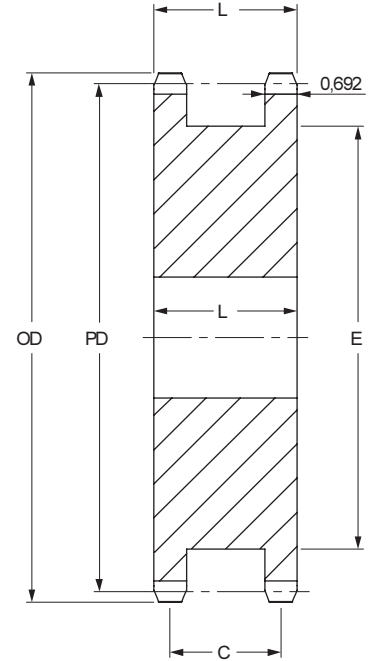

Double Simplex Taper Bushed Type A

No. Teeth	Bushing Size	Diameters		Type	Bore		Dimensions				Weight* lbs	Designation
		Outside	Pitch		Min	Max	L1	C	E	L2		
		Inch	Inch		Inch	Inch	Inch	Inch	Inch	Inch		
15	2517	6,63	6,01	A	3/4	2 1/2	2 11/16	2	4 19/32	1 3/4	12,5	PHS 100-1DSTB15
16	2517	7,03	6,41	A	3/4	2 1/2	2 11/16	2	5	1 3/4	13,0	PHS 100-1DSTB16
17	3020	7,44	6,80	A	15/16	3	2 11/16	2	5 13/32	2	14,0	PHS 100-1DSTB17
18	3020	7,84	7,20	A	15/16	3	2 11/16	2	5 53/64	2	16,0	PHS 100-1DSTB18
19	3020	8,24	7,59	A	15/16	3	2 11/16	2	6 13/64	2	20,0	PHS 100-1DSTB19
20	3020	8,64	7,99	A	15/16	3	2 11/16	2	6 39/64	1 3/4	27,5	PHS 100-1DSTB20
21	3020	9,04	8,39	A	15/16	3	2 11/16	2	7	2	27,5	PHS 100-1DSTB21

* Weight for rim only

For hardened teeth sprockets, add "H" after the sprocket profile e.g. PHS 08B-1AH8.

Type A Taper Bush

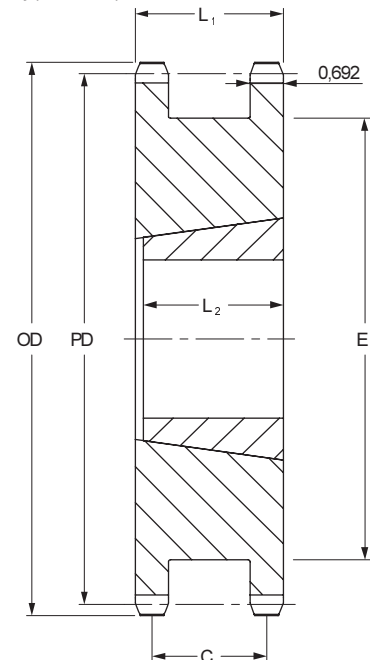

ANSI sprockets

Double Simplex



ANSI 120-1 1 1/2" Pitch

Double Simplex Type A

No. Teeth	Diameter		Type	Bore		Dimensions			Weight	Designation
	Outside	Pitch		Min	Max	L	C	E		
	Inch	Inch		Inch	Inch	Inch	Inch	Inch		
15	7,96	7,21	A	1 ⁷ / ₁₆	3 ³ / ₄	3 ¹¹ / ₃₂	2 ⁷ / ₁₆	5 ¹ / ₂	30	PHS 120-1DSA15
16	8,44	7,69	A	1 ⁷ / ₁₆	4	3 ¹¹ / ₃₂	2 ⁷ / ₁₆	6	34	PHS 120-1DSA16
17	8,92	8,16	A	1 ⁷ / ₁₆	4 ⁷ / ₁₆	3 ¹¹ / ₃₂	2 ⁷ / ₁₆	6 ³¹ / ₆₄	37	PHS 120-1DSA17
18	9,41	8,64	A	1 ⁷ / ₁₆	5 ³ / ₁₆	3 ¹¹ / ₃₂	2 ⁷ / ₁₆	6 ³¹ / ₆₄	42	PHS 120-1DSA18
19	9,89	9,11	A	1 ⁷ / ₁₆	5 ¹ / ₂	3 ¹¹ / ₃₂	2 ⁷ / ₁₆	7 ²⁹ / ₆₄	47	PHS 120-1DSA19
20	10,37	9,59	A	1 ⁷ / ₁₆	5 ¹⁵ / ₁₆	3 ¹¹ / ₃₂	2 ⁷ / ₁₆	7 ¹⁵ / ₁₆	51	PHS 120-1DSA20

For hardened teeth sprockets, add "H" after the sprocket profile e.g. PHS 08B-1AH8.

ANSI 140-1 1 3/4" Pitch

Double Simplex Type A

No. Teeth	Diameter		Type	Bore		Dimensions			Weight	Designation
	Outside	Pitch		Min	Max	L	C	E		
	Inch	Inch		Inch	Inch	Inch	Inch	Inch		
14	8,72	7,86	A	1 ⁷ / ₁₆	3 ⁷ / ₈	3 ³⁹ / ₆₄	2 ¹¹ / ₁₆	5 ⁷ / ₈	35	PHS 140-1DSA14
15	9,28	8,42	A	1 ⁷ / ₁₆	4 ⁷ / ₁₆	3 ³⁹ / ₆₄	2 ¹¹ / ₁₆	6 ²⁹ / ₆₄	43	PHS 140-1DSA15
16	9,85	8,97	A	1 ⁷ / ₁₆	5 ¹ / ₄	3 ³⁹ / ₆₄	2 ¹¹ / ₁₆	7 ¹ / ₆₄	49	PHS 140-1DSA16
17	10,41	9,52	A	1 ⁷ / ₁₆	5 ⁹ / ₁₆	3 ³⁹ / ₆₄	2 ¹¹ / ₁₆	7 ³⁷ / ₆₄	58	PHS 140-1DSA17
18	10,98	10,08	A	1 ⁷ / ₁₆	6 ¹ / ₈	3 ³⁹ / ₆₄	2 ¹¹ / ₁₆	8 ⁹ / ₆₄	66	PHS 140-1DSA18

For hardened teeth sprockets, add "H" after the sprocket profile e.g. PHS 08B-1AH8.

ANSI 160-1 2" Pitch

Double Simplex Type A

No. Teeth	Diameter		Type	Bore		Dimensions			Weight	Designation
	Outside	Pitch		Min	Max	L	C	E		
	Inch	Inch		Inch	Inch	Inch	Inch	Inch		
15	10,61	9,62	A	1 ¹¹ / ₁₆	5 ¹ / ₂	4 ¹ / ₄	3 ³ / ₃₂	7 ³ / ₈	69	PHS 160-1DSA15
16	11,26	10,25	A	1 ¹¹ / ₁₆	6	4 ¹ / ₄	3 ³ / ₃₂	8 ¹ / ₆₄	75	PHS 160-1DSA16
17	11,90	10,88	A	1 ¹¹ / ₁₆	6 ¹ / ₂	4 ¹ / ₄	3 ³ / ₃₂	8 ²¹ / ₃₂	92	PHS 160-1DSA17
18	12,54	11,52	A	1 ¹¹ / ₁₆	6 ³ / ₁₆	4 ¹ / ₄	3 ³ / ₃₂	9 ⁵ / ₁₆	97	PHS 160-1DSA18

For hardened teeth sprockets, add "H" after the sprocket profile e.g. PHS 08B-1AH8.

Type A

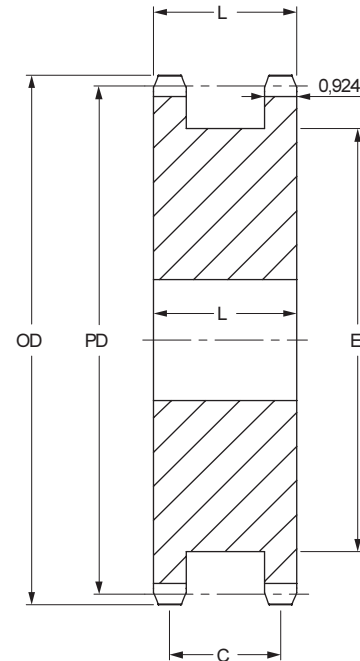



ANSI sprockets

Duplex
Pilot Bore

- ▶ Belts
- ▶ Chains
- ▶ Couplings
- ▶ Bushings and Hubs
- ▶ Sprockets
- ▶ Pulleys
- ▶ Smart tools

ANSI 35-2 3/8" Pitch

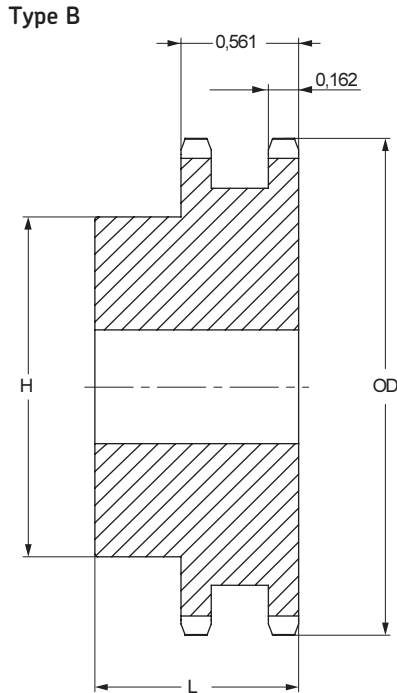

ANSI 40-2 1/2" Pitch

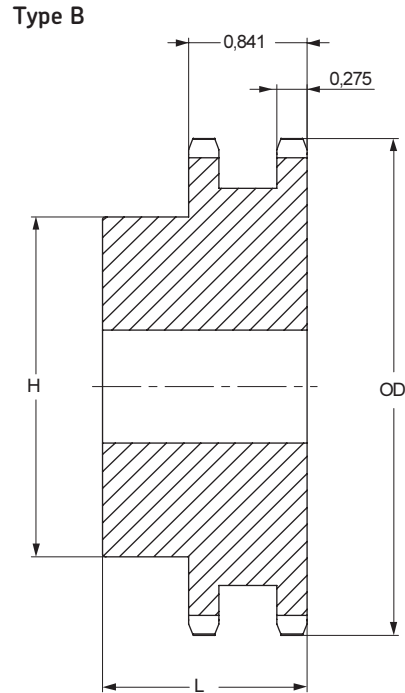

Pilot Bore Type B

No. Teeth	Outside Diameter	Type	Bore		Hub		Weight	Designation
			Min	Max	H	L		
			Inch	Inch	Inch	Inch		
12	1,63	B	1/2	3/16	63/64	1 1/4	0,32	PHS 35-2B12
13	1,75	B	1/2	11/16	1 7/64	1 1/4	0,36	PHS 35-2B13
14	1,87	B	1/2	7/8	1 1/4	1 1/4	0,44	PHS 35-2B14
15	1,99	B	1/2	15/16	1 13/32	1 3/4	0,56	PHS 35-2B15
16	2,11	B	1/2	15/16	1 15/32	1 3/4	0,64	PHS 35-2B16
17	2,23	B	1/2	11/16	1 13/32	1 3/4	0,74	PHS 35-2B17
18	2,35	B	1/2	13/16	1 23/32	1 3/4	0,84	PHS 35-2B18
19	2,47	B	1/2	15/16	1 7/8	1 3/4	0,96	PHS 35-2B19
20	2,59	B	3/4	15/16	1 15/16	1 3/8	1,08	PHS 35-2B20
21	2,71	B	3/4	1 3/8	2 1/16	1 3/8	1,24	PHS 35-2B21
22	2,83	B	3/4	1 7/16	2 3/16	1 3/8	1,42	PHS 35-2B22
23	2,95	B	3/4	1 1/2	2 1/4	1 3/8	1,54	PHS 35-2B23
24	3,07	B	3/4	1 1/2	2 1/4	1 3/8	1,62	PHS 35-2B24
25	3,19	B	3/4	1 1/2	2 1/4	1 3/8	1,66	PHS 35-2B25
26	3,31	B	3/4	1 3/4	2 1/2	1 3/8	1,98	PHS 35-2B26
30	3,79	B	3/4	1 3/4	2 1/2	1 3/8	2,34	PHS 35-2B30
36	4,51	B	3/4	1 3/4	2 1/2	1 3/8	3,00	PHS 35-2B36
42	5,23	B	3/4	1 3/4	2 1/2	1 3/8	3,80	PHS 35-2B42
48	5,95	B	3/4	1 3/4	2 1/2	1 3/8	4,66	PHS 35-2B48
52	6,43	B	3/4	1 3/4	2 1/2	1 3/8	5,40	PHS 35-2B52
60	7,38	B	3/4	1 3/4	2 1/2	1 3/8	6,84	PHS 35-2B60
68	8,34	B	3/4	2 3/8	3 1/2	1 1/2	10,01	PHS 35-2B68
72	8,81	B	3/4	2 3/8	3 1/2	1 1/2	11,04	PHS 35-2B72
76	9,29	B	3/4	2 3/8	3 1/2	1 1/2	11,94	PHS 35-2B76
84	10,25	B	3/4	2 3/8	3 1/2	1 1/2	14,98	PHS 35-2B84
95	11,56	B	1	2 3/8	3 1/2	1 1/2	17,42	PHS 35-2B95
96	11,68	B	1	2 3/8	3 1/2	1 1/2	18,14	PHS 35-2B96
102	12,40	B	1	2 3/8	3 1/2	1 1/2	19,92	PHS 35-2B102

Maximum bores can accommodate standard keyways. Larger bores are available where a shallow keyway is used or no keyway is required. For hardened teeth sprockets, add "H" after the sprocket profile e.g. PHS 08B-1AH8.

Pilot Bore Type B

No. Teeth	Outside Diameter	Type	Bore		Hub		Weight	Designation
			Min	Max	H	L		
			Inch	Inch	Inch	Inch		
11	2,00	B	1/2	3/4	1 7/16	1 1/2	0,62	PHS 40-2B11
12	2,17	B	1/2	15/16	1 7/16	1 1/2	0,76	PHS 40-2B12
13	2,33	B	1/2	1	1 1/2	1 1/2	0,86	PHS 40-2B13
14	2,49	B	1/2	1 1/8	1 13/16	1 1/2	1,08	PHS 40-2B14
15	2,65	B	1/2	1 1/4	1 13/16	1 1/2	1,24	PHS 40-2B15
16	2,81	B	5/8	1 3/8	2	1 1/2	1,42	PHS 40-2B16
17	2,98	B	5/8	1 7/16	2 1/8	1 1/2	1,64	PHS 40-2B17
18	3,14	B	5/8	1 1/2	2 3/16	1 1/2	1,92	PHS 40-2B18
19	3,30	B	5/8	1 3/4	2 1/2	1 1/2	2,22	PHS 40-2B19
20	3,46	B	5/8	1 7/8	2 5/8	1 5/8	2,64	PHS 40-2B20
21	3,62	B	5/8	1 7/8	2 3/4	1 5/8	2,94	PHS 40-2B21
22	3,78	B	5/8	1 7/8	2 3/4	1 5/8	3,18	PHS 40-2B22
23	3,94	B	5/8	2	3	1 5/8	3,52	PHS 40-2B23
24	4,10	B	5/8	2 1/4	3 1/4	1 5/8	4,04	PHS 40-2B24
25	4,26	B	5/8	2 1/4	3 1/4	1 5/8	4,26	PHS 40-2B25
26	4,42	B	5/8	2 1/4	3 1/4	1 5/8	4,48	PHS 40-2B26
30	5,06	B	7/8	2 1/4	3 1/4	1 5/8	5,34	PHS 40-2B30
35	5,86	B	7/8	2 1/4	3 1/4	1 5/8	6,80	PHS 40-2B35
36	6,02	B	15/16	2 1/2	3 3/4	1 5/8	7,20	PHS 40-2B36
40	6,65	B	15/16	2 1/2	3 3/4	1 5/8	9,40	PHS 40-2B40
42	6,97	B	15/16	2 1/2	3 3/4	1 3/4	10,20	PHS 40-2B42
45	7,45	B	15/16	2 1/2	3 3/4	1 3/4	11,36	PHS 40-2B45
48	7,93	B	15/16	2 1/2	3 3/4	1 3/4	12,66	PHS 40-2B48
52	8,57	B	15/16	2 1/2	3 3/4	1 3/4	14,46	PHS 40-2B52
54	8,89	B	15/16	2 1/2	3 3/4	1 3/4	15,48	PHS 40-2B54
60	9,84	B	15/16	2 1/2	3 3/4	1 3/4	18,60	PHS 40-2B60
68	11,12	B	1 3/16	2 3/4	4 1/4	2 1/8	24,96	PHS 40-2B68
72	11,75	B	1 3/16	2 3/4	4 1/4	2 1/8	27,88	PHS 40-2B72
76	12,39	B	1 3/16	2 3/4	4 1/4	2 1/8	30,18	PHS 40-2B76
84	13,66	B	1 3/16	2 3/4	4 1/4	2 1/8	36,24	PHS 40-2B84
95	15,41	B	1 3/16	2 3/4	4 1/4	2 1/8	38,84	PHS 40-2B95
96	15,57	B	1 3/16	2 3/4	4 1/4	2 1/8	39,50	PHS 40-2B96
102	16,53	B	1 3/16	2 3/4	4 1/4	2 1/8	42,72	PHS 40-2B102
112	18,12	B	1 3/16	2 3/4	4 1/4	2 1/8	55,54	PHS 40-2B112

Maximum bores can accommodate standard keyways. Larger bores are available where a shallow keyway is used or no keyway is required. For hardened teeth sprockets, add "H" after the sprocket profile e.g. PHS 08B-1AH8.



ANSI sprockets



Duplex
Pilot Bore

ANSI 50-2 5/8" Pitch

Type B

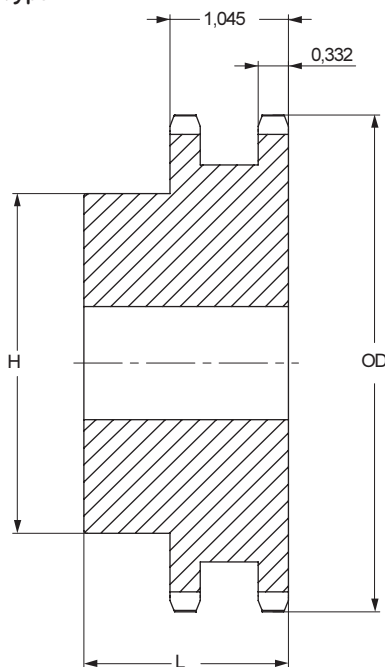

ANSI 60-2 3/4" Pitch

Type B

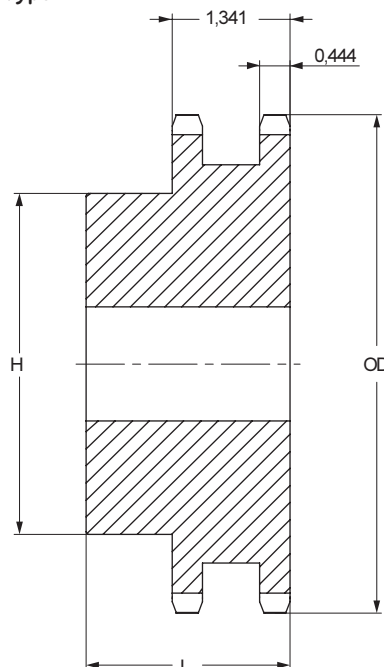

Type C

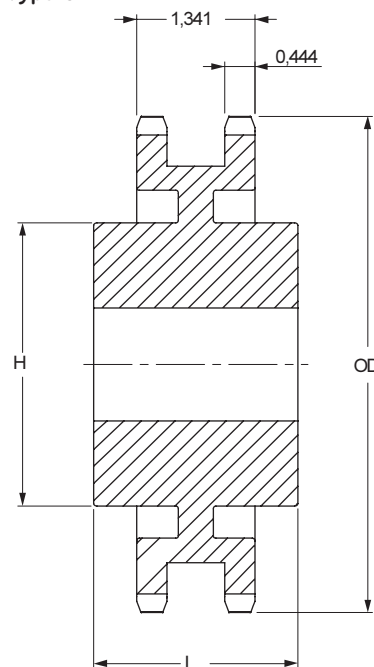

Pilot Bore Type B

No. Teeth	Outside Diameter	Type	Bore		Hub		Weight	Designation
			Min	Max	H	L		
			Inch	Inch	Inch	Inch		
11	2,50	B	5/8	1 1/16	1 15/32	1 3/4	0,96	PHS 50-2B11
12	2,71	B	5/8	1 1/8	1 11/16	1 3/4	1,25	PHS 50-2B12
13	2,91	B	5/8	1 5/16	1 7/8	1 3/4	1,56	PHS 50-2B13
14	3,11	B	5/8	1 3/8	2 1/16	1 3/4	1,86	PHS 50-2B14
15	3,32	B	3/4	1 1/2	2 5/16	1 3/4	2,22	PHS 50-2B15
16	3,52	B	3/4	1 3/4	2 1/2	1 3/4	2,62	PHS 50-2B16
17	3,72	B	3/4	1 7/8	2 11/16	1 3/4	3,04	PHS 50-2B17
18	3,92	B	3/4	1 15/16	2 15/16	1 3/4	3,58	PHS 50-2B18
19	4,12	B	1	2 1/8	3 3/8	1 3/4	3,90	PHS 50-2B19
20	4,32	B	1	2 1/4	3 1/4	1 3/4	4,26	PHS 50-2B20
21	4,52	B	1	2 3/8	3 1/2	1 3/4	4,90	PHS 50-2B21
22	4,72	B	1	2 3/8	3 9/16	1 7/8	5,58	PHS 50-2B22
23	4,92	B	1	2 1/2	3 5/8	1 7/8	6,10	PHS 50-2B23
24	5,12	B	1	2 1/2	3 3/8	1 7/8	6,50	PHS 50-2B24
25	5,32	B	1	2 1/2	3 5/8	1 7/8	6,94	PHS 50-2B25
26	5,52	B	1	2 1/2	3 3/4	1 7/8	7,54	PHS 50-2B26
30	6,32	B	1	2 1/2	3 3/4	1 7/8	9,40	PHS 50-2B30
32	6,72	B	1	2 3/4	3 3/4	1 7/8	10,46	PHS 50-2B32
35	7,32	B	1	2 1/2	3 3/4	1 7/8	12,28	PHS 50-2B35
36	7,52	B	1 3/16	2 3/4	4	2 1/8	13,94	PHS 50-2B36
40	8,32	B	1 3/16	2 3/4	4	2 1/8	16,54	PHS 50-2B40
42	8,72	B	1 3/16	2 3/4	4	2 3/8	17,92	PHS 50-2B42
45	9,31	B	1 3/16	2 3/4	4	2 3/8	20,30	PHS 50-2B45
48	9,91	B	1 3/16	2 3/4	4 1/4	2 3/8	24,08	PHS 50-2B48
52	10,71	B	1 3/16	2 3/4	4 1/4	2 3/8	27,42	PHS 50-2B52
54	11,11	B	1 3/16	2 3/4	4 1/4	2 3/8	29,16	PHS 50-2B54
60	12,30	B	1 3/16	3	4 1/2	2 3/8	35,88	PHS 50-2B60
68	13,89	B	1 3/16	3	4 1/2	2 3/8	44,98	PHS 50-2B68
72	14,69	B	1 3/16	3	4 1/2	2 3/8	50,22	PHS 50-2B72
76	15,49	B	1 3/16	3	4 1/2	2 3/8	55,64	PHS 50-2B76
84	17,08	B	1 5/16	3	4 1/2	2 3/8	51,64	PHS 50-2B84
95	19,27	B	1 5/16	3	4 1/2	2 3/8	64,32	PHS 50-2B95
96	19,47	B	1 5/16	3	4 1/2	2 3/8	67,42	PHS 50-2B96
102	20,66	B	1 5/16	3	4 1/2	2 3/8	72,68	PHS 50-2B102
112	22,65	B	1 5/16	3 1/16	5 1/4	2 3/8	90,22	PHS 50-2B112

Pilot Bore Type B/C

No. Teeth	Outside Diameter	Type	Bore		Hub		Weight	Designation
			Min	Max	H	L		
			Inch	Inch	Inch	Inch		
11	3,00	B	1	1 1/4	1 13/16	2 1/8	1,62	PHS 60-2B11
12	3,25	B	1	1 1/4	2 1/8	2 1/8	2,20	PHS 60-2B12
13	3,49	B	1	1 1/2	2 1/4	2 1/8	2,60	PHS 60-2B13
14	3,74	B	1	1 1/4	2 3/2	2 1/8	3,24	PHS 60-2B14
15	3,98	B	1	1 1/8	2 13/16	2 1/8	3,96	PHS 60-2B15
16	4,22	B	1	2	3	2 1/8	4,62	PHS 60-2B16
17	4,46	B	1	2 1/4	3 1/4	2 1/8	5,40	PHS 60-2B17
18	4,70	B	1	2 3/8	3 1/2	2 3/8	6,24	PHS 60-2B18
19	4,95	B	1	2 1/2	3 13/16	2 3/8	7,00	PHS 60-2B19
20	5,19	B	1	2 1/2	3 3/4	2 3/8	7,72	PHS 60-2B20
21	5,43	B	1	2 3/4	4 1/8	2 3/8	8,82	PHS 60-2B21
22	5,67	B	1	2 3/4	4 1/4	2 3/8	9,68	PHS 60-2B22
23	5,91	B	1	2 3/4	4 1/4	2 3/8	10,30	PHS 60-2B23
24	6,15	B	1	2 3/4	4 3/4	2 3/8	11,14	PHS 60-2B24
25	6,39	B	1	2 3/4	4 1/4	2 3/8	11,96	PHS 60-2B25
26	6,63	B	1	2 3/4	4 3/4	2 3/8	12,70	PHS 60-2B26
30	7,59	B	1	2 3/4	4 1/4	2 3/8	16,36	PHS 60-2B30
32	8,07	B	1 1/4	3	4 1/2	2 3/8	19,52	PHS 60-2B32
35	8,78	B	1 1/4	3	4 1/2	2 3/8	22,80	PHS 60-2B35
36	9,02	B	1 1/4	3	4 3/2	2 3/8	23,82	PHS 60-2B36
40	9,98	B	1 1/4	3 1/4	4 3/4	2 3/8	30,84	PHS 60-2B40
42	10,46	B	1 1/4	3 1/4	4 3/4	2 3/8	33,08	PHS 60-2B42
45	11,18	B	1 1/4	3 1/4	4 3/4	2 3/8	37,08	PHS 60-2B45
52	12,85	B	1 1/4	3 1/4	4 3/4	2 3/8	48,70	PHS 60-2B52
60	14,76	B	1 1/4	3 1/4	4 3/4	2 3/8	63,10	PHS 60-2B60
68	16,67	C	1 1/4	3 1/16	5	3	53,68	PHS 60-2C68
72	17,63	C	1 1/4	3 1/16	5	3	53,74	PHS 60-2C72
76	18,58	C	1 1/4	3 1/16	5	3	60,28	PHS 60-2C76
95	23,12	C	1 1/4	3 1/4	5 1/2	3 1/2	87,14	PHS 60-2C95

Maximum bores can accommodate standard keyways. Larger bores are available where a shallow keyway is used or no keyway is required. For hardened teeth sprockets, add "H" after the sprocket profile e.g. PHS 08B-1AH8.

Maximum bores can accommodate standard keyways. Larger bores are available where a shallow keyway is used or no keyway is required. For hardened teeth sprockets, add "H" after the sprocket profile e.g. PHS 08B-1AH8



ANSI sprockets

Duplex
Pilot Bore

- ▶ Belts
- ▶ Chains
- ▶ Couplings
- ▶ Bushings and Hubs
- ▶ Sprockets
- ▶ Pulleys
- ▶ Smart tools

ANSI 80-2 1" Pitch

ANSI 100-2 1 1/4" Pitch

Type B

Type C

Type B

Type C

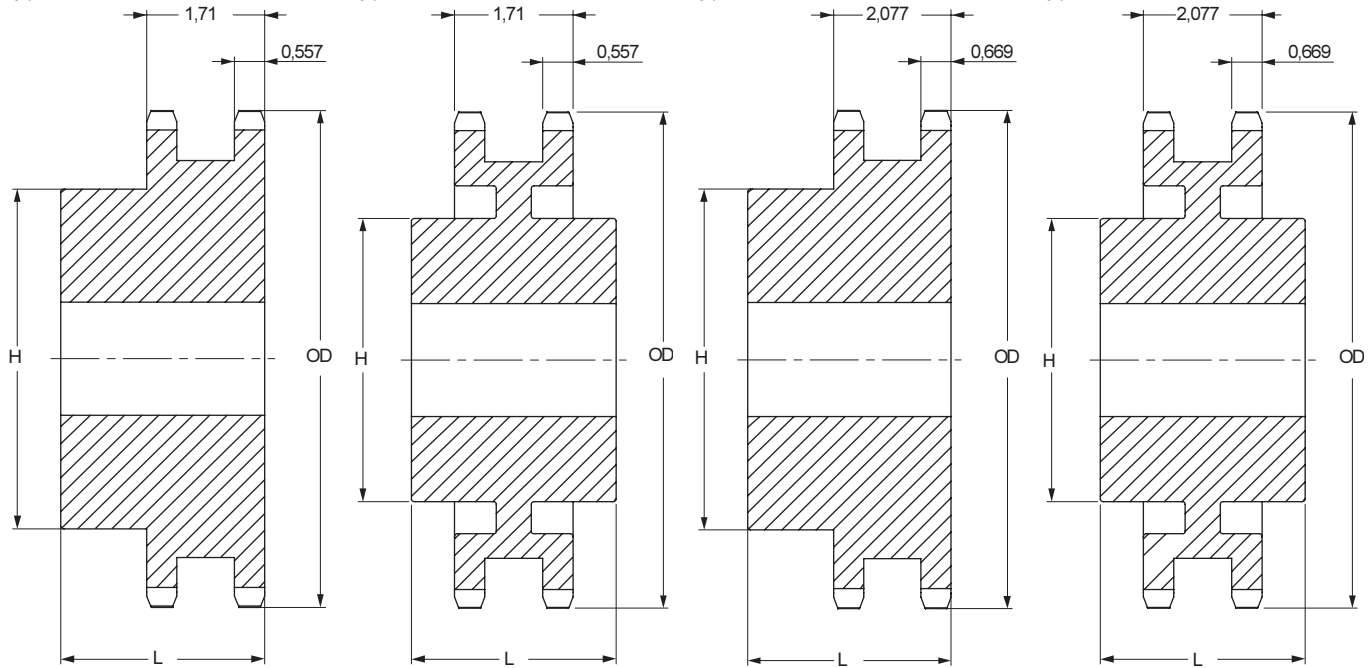

Pilot Bore Type B/C

Pilot Bore Type B/C

No. Teeth	Outside Diameter	Type	Bore		Hub		Weight lbs	Designation
			Min	Max	H	L		
			Inch	Inch	Inch	Inch		
10	3,68	B	1	1 1/2	2 3/16	2 3/4	3,60	PHS 80-2B10
11	4,01	B	1	1 3/4	2 1/2	2 1/2	4,00	PHS 80-2B11
12	4,33	B	1	1 7/8	2 27/32	2 1/2	5,10	PHS 80-2B12
13	4,66	B	1	2 1/4	3 3/32	2 3/2	6,30	PHS 80-2B13
14	4,98	B	1	2 3/8	3 15/32	2 1/2	7,60	PHS 80-2B14
15	5,30	B	1	2 1/2	3 51/64	2 1/2	9,00	PHS 80-2B15
16	5,63	B	1	2 3/4	4	2 3/4	11,00	PHS 80-2B16
17	5,95	B	1	3	4 27/64	2 3/4	13,20	PHS 80-2B17
18	6,27	B	1	3 1/4	4 47/64	2 3/4	15,00	PHS 80-2B18
19	6,59	B	1	3 5/16	5	2 3/4	17,00	PHS 80-2B19
20	6,91	B	1	3 7/16	5	2 3/4	18,20	PHS 80-2B20
21	7,24	B	1	3 5/16	5	2 3/4	19,60	PHS 80-2B21
22	7,56	B	1	3 7/16	5	2 3/4	21,00	PHS 80-2B22
23	7,88	B	1	3 5/16	5	2 3/4	22,80	PHS 80-2B23
24	8,20	B	1	3 1/2	5 1/4	2 3/4	25,10	PHS 80-2B24
25	8,52	B	1	3 1/2	5 3/4	3	28,30	PHS 80-2B25
26	8,84	B	1	3 1/2	5 1/4	3	29,90	PHS 80-2B26
30	10,11	B	1	3 3/4	5 3/4	3	39,50	PHS 80-2B30
32	10,75	B	1	3 3/4	5 3/4	3	43,80	PHS 80-2B32
35	11,71	B	1	3 3/4	5 3/4	3	49,10	PHS 80-2B35
36	12,03	B	1	3 3/4	5 3/4	3 1/8	54,20	PHS 80-2B36
42	13,94	B	1	3 3/4	5 3/4	3 3/8	71,50	PHS 80-2B42
45	14,90	B	1	3 3/4	5 3/4	3 1/8	73,50	PHS 80-2B45
52	17,13	C	1	3 3/4	5 3/4	3 3/4	78,40	PHS 80-2C52
60	19,68	C	1	3 3/4	5 3/4	3 3/4	93,30	PHS 80-2C60
68	22,23	C	1	3 3/4	5 3/4	6	96,20	PHS 80-2C68
76	24,78	C	1	3 3/4	5 3/4	6	113,00	PHS 80-2C76
95	30,83	C	1	3 3/4	6	4 1/4	165,00	PHS 80-2C95

No. Teeth	Outside Diameter	Type	Bore		Hub		Weight lbs	Designation
			Min	Max	H	L		
			Inch	Inch	Inch	Inch		
9	4,18	B	1	1 5/8	2 3/8	2 7/8	4,60	PHS 100-2B9
10	4,60	B	1	1 7/8	2 3/4	2 7/8	6,20	PHS 100-2B10
11	5,01	B	1	2 1/8	3 3/8	2 7/8	7,90	PHS 100-2B11
12	5,42	B	1	2 1/4	3 3/8	2 7/8	9,30	PHS 100-2B12
13	5,82	B	1	2 1/2	3 13/16	2 7/8	11,40	PHS 100-2B13
14	6,23	B	1	2 3/4	4 47/64	2 7/8	13,60	PHS 100-2B14
15	6,63	B	1	2 3/4	4 5/8	3 1/8	17,10	PHS 100-2B15
16	7,03	B	1	3 1/8	5 3/16	3 1/8	20,10	PHS 100-2B16
17	7,44	B	1	3 1/2	5 1/4	3 1/8	23,10	PHS 100-2B17
18	7,84	B	1	3 1/2	5 1/4	3 1/8	25,40	PHS 100-2B18
19	8,24	B	1	3 3/4	5 1/2	3 3/8	29,60	PHS 100-2B19
20	8,64	B	1	3 3/4	5 1/2	3 3/8	32,40	PHS 100-2B20
21	9,04	B	1	3 3/4	5 1/2	3 3/8	35,30	PHS 100-2B21
22	9,44	B	1	3 3/4	5 1/2	3 3/8	38,40	PHS 100-2B22
23	9,84	B	1	3 3/4	5 1/2	3 3/8	41,30	PHS 100-2B23
24	10,25	B	1	3 3/4	5 1/2	3 3/8	45,10	PHS 100-2B24
25	10,65	B	1	3 3/4	5 3/4	3 3/8	48,50	PHS 100-2B25
26	11,05	B	1	3 3/4	5 3/4	3 3/8	51,50	PHS 100-2B26
30	12,64	B	1	3 3/4	5 3/4	3 3/8	65,00	PHS 100-2B30
35	14,64	C	1	3 3/4	6	4 1/4	75,00	PHS 100-2C35
45	18,63	C	1	3 3/4	6	4 1/2	103,00	PHS 100-2C45
60	24,60	C	1	3 3/4	7 1/2	5	175,00	PHS 100-2C60
70	28,58	C	1	3 3/4	7 1/2	5	197,00	PHS 100-2C70
80	32,57	C	1	3 3/4	7 1/2	5	231,00	PHS 100-2C80

Maximum bores can accommodate standard keyways. Larger bores are available where a shallow keyway is used or no keyway is required. For hardened teeth sprockets, add "H" after the sprocket profile e.g. PHS 08B-1AH8.

Maximum bores can accommodate standard keyways. Larger bores are available where a shallow keyway is used or no keyway is required. For hardened teeth sprockets, add "H" after the sprocket profile e.g. PHS 08B-1AH8.

ANSI sprockets

Duplex
Pilot Bore



ANSI 120-2 1 1/2" Pitch

ANSI 140-2 1 3/4" Pitch

Type B

Type C

Type B

Type C

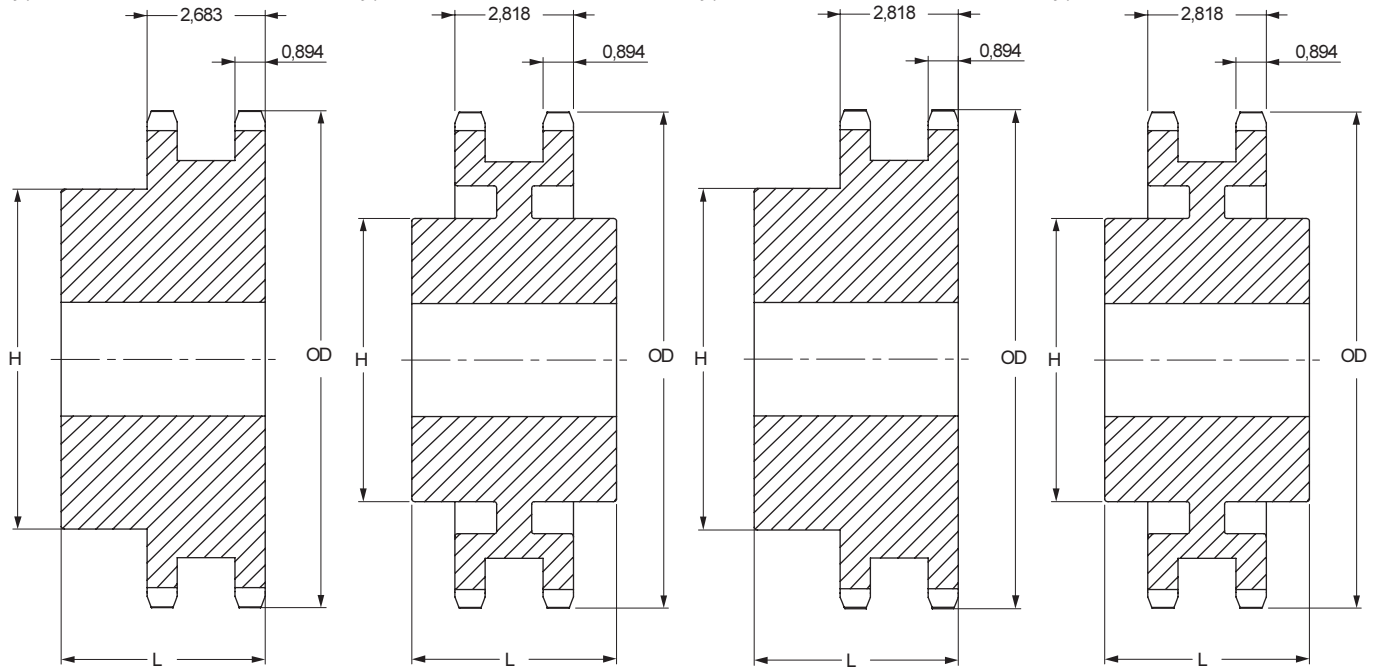

Pilot Bore Type B/C

No. Teeth	Outside Diameter	Type	Bore		Hub		Weight lbs	Designation
			Min	Max	H	L		
			Inch	Inch	Inch	Inch		
11	6,01	B	1 1/2	2 3/8	3 3/16	3 3/4	13,60	PHS 120-2B11
12	6,50	B	1 1/2	2 3/4	4 1/16	3 3/4	17,30	PHS 120-2B12
13	6,99	B	1 1/2	3	4 1/2	3 3/4	21,10	PHS 120-2B13
14	7,47	B	1 1/2	3 5/16	5	3 3/4	25,60	PHS 120-2B14
15	7,96	B	1 1/2	3 1/2	5 1/4	3 3/4	29,90	PHS 120-2B15
16	8,44	B	1 1/2	3 3/2	5 3/4	3 3/4	33,80	PHS 120-2B16
17	8,92	B	1 1/2	3 1/2	5 1/4	3 3/4	36,90	PHS 120-2B17
18	9,41	B	1 1/2	3 3/2	5 1/4	3 3/4	41,90	PHS 120-2B18
19	9,89	B	1 1/2	3 1/2	5 1/4	3 3/4	46,50	PHS 120-2B19
20	10,37	B	1 1/2	3 1/2	5 1/2	3 3/4	50,20	PHS 120-2B20
21	10,85	B	1 1/2	3 1/2	5 1/2	3 3/4	55,60	PHS 120-2B21
22	11,33	B	1 1/2	3 3/16	5 3/4	4	64,00	PHS 120-2B22
23	11,81	B	1 1/2	4 1/2	6 1/2	4	75,00	PHS 120-2B23
24	12,29	B	1 1/2	4 3/2	6 3/2	4	79,00	PHS 120-2B24
25	12,77	B	1 1/2	4 1/2	6 1/2	4	84,00	PHS 120-2B25
26	13,25	B	1 1/2	4 3/2	6 1/2	4	90,00	PHS 120-2B26
30	15,17	B	1 1/2	4 1/2	6 1/2	4	119,00	PHS 120-2B30
35	17,57	C	1 1/2	5 3/8	7 1/2	6	148,00	PHS 120-2C35
45	22,35	C	1 1/2	5 3/8	7 1/2	6	188,00	PHS 120-2C45
60	29,52	C	1 1/2	6 3/8	9 1/2	6 1/4	307,00	PHS 120-2C60

Maximum bores can accommodate standard keyways. Larger bores are available where a shallow keyway is used or no keyway is required. For hardened teeth sprockets, add "H" after the sprocket profile e.g. PHS 08B-1AH8.

Pilot Bore Type B/C

No. Teeth	Outside Diameter	Type	Bore		Hub		Weight lbs	Designation
			Min	Max	H	L		
			Inch	Inch	Inch	Inch		
13	8,15	B	1 5/8	3 7/16	5	3 3/4	29,00	PHS 140-2B13
14	8,72	B	1 5/8	3 3/4	5 1/2	3 3/4	34,80	PHS 140-2B14
15	9,28	B	1 5/8	4 1/2	6 1/2	3 3/4	42,50	PHS 140-2B15
16	9,85	B	1 5/8	5 1/4	7	4	48,10	PHS 140-2B16
17	10,41	B	1 5/8	5 1/4	7	4	57,50	PHS 140-2B17
18	10,98	B	1 3/4	5 1/4	7	4	65,60	PHS 140-2B18
19	11,54	B	1 3/4	5 1/4	7	4	72,00	PHS 140-2B19
20	12,10	B	1 3/4	5 1/4	7	4	76,00	PHS 140-2B20
21	12,66	B	1 3/4	5 1/4	7	4	82,00	PHS 140-2B21
22	13,22	B	1 3/4	5 1/4	7	4	94,00	PHS 140-2B22
23	13,78	B	1 3/4	5 1/4	7	4	100,00	PHS 140-2B23
24	14,34	B	1 3/4	5 1/4	7	4	104,00	PHS 140-2B24
25	14,90	B	1 3/4	5 1/4	7	4	120,00	PHS 140-2B25
26	15,46	B	1 3/4	5 1/4	7	4	128,00	PHS 140-2B26
35	20,49	C	1 1/2	5 3/8	7 1/2	6	180,00	PHS 140-2C35
45	26,08	C	1 1/2	5 3/8	7 1/2	6	232,00	PHS 140-2C45
60	34,44	C	1 1/2	6 3/8	9 1/2	6 1/4	372,00	PHS 140-2C60

Maximum bores can accommodate standard keyways. Larger bores are available where a shallow keyway is used or no keyway is required. For hardened teeth sprockets, add "H" after the sprocket profile e.g. PHS 08B-1AH8.



ANSI sprockets

Duplex

Pilot Bore

- ▶ Belts
- ▶ Chains
- ▶ Couplings
- ▶ Bushings and Hubs
- ▶ Sprockets
- ▶ Pulleys
- ▶ Smart tools

ANSI 160-2 2" Pitch

ANSI 200-2 2 1/2" Pitch

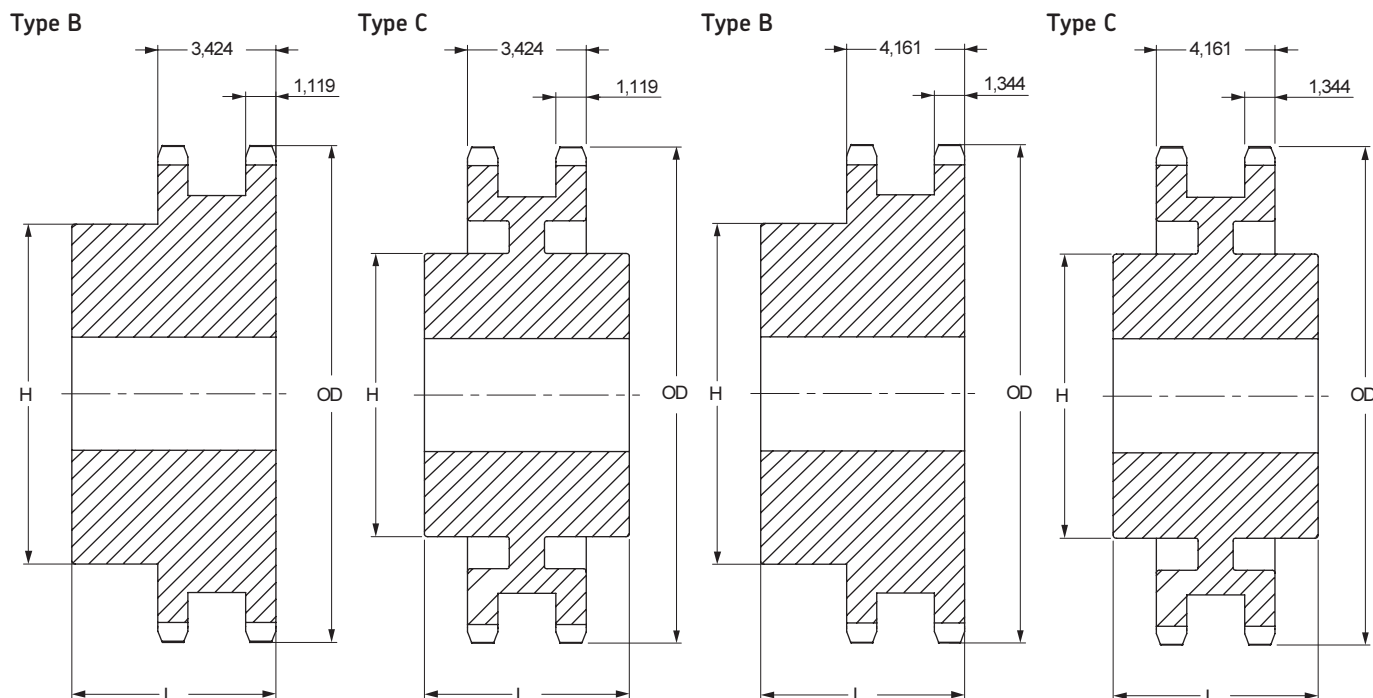

Pilot Bore Type B/C

Pilot Bore Type B/C

No. Teeth	Outside Diameter	Type	Bore		Hub		Weight	Designation
			Min	Max	H	L		
			Inch	Inch	Inch	Inch		
13	9.31	B	2	4	6	4 3/4	48,00	PHS 160-2B13
14	9.96	B	2	4 3/4	6 3/4	4 3/4	58,00	PHS 160-2B14
15	10.61	B	2	5 1/4	7	4 3/4	68,00	PHS 160-2B15
16	11.26	B	2	5 3/4	7	4 3/4	75,00	PHS 160-2B16
17	11.90	B	2	5 3/4	7	4 3/4	91,00	PHS 160-2B17
18	12.54	B	2	5 3/4	7	4 3/4	96,00	PHS 160-2B18
19	13.19	B	2	5 3/4	7	4 3/4	107,00	PHS 160-2B19
20	13.83	B	2	5 3/4	7	4 3/4	119,00	PHS 160-2B20
21	14.47	B	2	5 3/8	7 1/2	4 3/4	130,00	PHS 160-2B21
22	15.11	B	2	5 3/8	7 1/2	4 3/4	141,00	PHS 160-2B22
23	15.75	B	2	5 3/8	7 1/2	4 3/4	157,00	PHS 160-2B23
24	16.39	B	2	5 3/8	7 1/2	4 3/4	171,00	PHS 160-2B24
25	17.03	B	2	5 3/8	7 1/2	4 3/4	187,00	PHS 160-2B25
26	17.67	B	2	5 3/8	7 1/2	4 3/4	201,00	PHS 160-2B26
35	23.42	C	1 1/2	6 3/4	9 1/2	6 5/8	306,00	PHS 160-2C35
45	29.80	C	1 1/2	7	10	7 1/8	431,00	PHS 160-2C45
60	39.36	C	1 1/2	7	10	7 1/8	564,00	PHS 160-2C60

No. Teeth	Outside Diameter	Type	Bore		Hub		Weight	Designation
			Min	Max	H	L		
			Inch	Inch	Inch	Inch		
11	10.02	B	2	3 3/4	5 1/2	5 7/8	57,00	PHS 200-2B11
12	10.83	B	2	4 1/2	6 1/2	6 1/4	80,00	PHS 200-2B12
13	11.64	B	2	5 1/4	7	6 3/8	96,00	PHS 200-2B13
14	12.46	B	2	5 1/2	8	6 3/8	119,00	PHS 200-2B14
15	13.26	B	2	5 3/4	8 1/2	6 3/8	138,00	PHS 200-2B15
16	14.07	B	2	5 3/4	8 1/2	6 5/8	161,00	PHS 200-2B16
17	14.87	B	2	5 3/4	8 1/2	6 5/8	178,00	PHS 200-2B17
18	15.68	B	2	5 3/4	8 1/2	6 5/8	196,00	PHS 200-2B18
19	16.48	B	2	5 3/4	8 1/2	6 5/8	217,00	PHS 200-2B19
20	17.29	B	2	5 3/4	8 1/2	6 5/8	236,00	PHS 200-2B20
21	18.09	B	2	5 3/4	8 1/2	6 5/8	250,00	PHS 200-2B21
22	18.89	B	2	5 3/4	8 1/2	6 5/8	284,00	PHS 200-2B22
23	19.69	B	2	5 3/4	8 1/2	6 5/8	308,00	PHS 200-2B23
24	20.49	B	2	5 3/4	8 1/2	6 5/8	330,00	PHS 200-2B24
25	21.29	B	2	5 3/4	8 1/2	6 5/8	358,00	PHS 200-2B25
26	22.09	B	2	5 3/4	8 1/2	6 5/8	386,00	PHS 200-2B26
45	37.25	C	1 1/2	7	10	8 1/2	665,00	PHS 200-2C45
60	49.20	C	1 1/2	7	10	9	972,00	PHS 200-2C60

Maximum bores can accommodate standard keyways. Larger bores are available where a shallow keyway is used or no keyway is required. For hardened teeth sprockets, add "H" after the sprocket profile e.g. PHS 08B-1AH8.

Maximum bores can accommodate standard keyways. Larger bores are available where a shallow keyway is used or no keyway is required. For hardened teeth sprockets, add "H" after the sprocket profile e.g. PHS 08B-1AH8.



ANSI sprockets



Duplex
Taper Bushed

ANSI 35-2 3/8" Pitch

Taper Bushed Type B

No. Teeth	Diameter		Type	Bushing Number	Bore		Dimensions		Weight		Designation
	Outside	Pitch			Min	Max	L	H	Rim	Bushing	
19	2,47	2,28	B	1008	$\frac{3}{8}$	1	$\frac{7}{8}$	1 $\frac{53}{64}$	0,6	0,3	PHS 35-2TB19
20	2,59	2,40	B	1008	$\frac{3}{8}$	1	$\frac{7}{8}$	1 $\frac{15}{16}$	0,8	0,3	PHS 35-2TB20
21	2,71	2,52	B	1008	$\frac{3}{8}$	1	$\frac{7}{8}$	2 $\frac{1}{16}$	1,4	0,3	PHS 35-2TB21
22	2,83	2,63	B	1008	$\frac{3}{8}$	1	$\frac{7}{8}$	2 $\frac{3}{16}$	1,7	0,3	PHS 35-2TB22
23	3,07	2,87	B	1210	$\frac{5}{8}$	1 $\frac{1}{4}$	1	2 $\frac{7}{16}$	1,8	0,6	PHS 35-2TB24
26	3,31	3,11	B	1210	$\frac{5}{8}$	1 $\frac{1}{4}$	1	2 $\frac{5}{8}$	2,0	0,6	PHS 35-2TB26
30	3,79	3,59	B	1610	$\frac{1}{2}$	1 $\frac{5}{8}$	1	3 $\frac{1}{8}$	1,8	0,9	PHS 35-2TB30
32	4,03	3,83	B	1610	$\frac{1}{2}$	1 $\frac{5}{8}$	1	3 $\frac{1}{4}$	2,0	0,9	PHS 35-2TB32
35	4,39	4,18	B	1610	$\frac{1}{2}$	1 $\frac{5}{8}$	1	3 $\frac{1}{4}$	2,3	0,9	PHS 35-2TB35
40	4,99	4,78	B	1610	$\frac{1}{2}$	1 $\frac{5}{8}$	1	3 $\frac{1}{4}$	2,9	0,9	PHS 35-2TB40
45	5,59	5,38	B	1610	$\frac{1}{2}$	1 $\frac{5}{8}$	1	3 $\frac{1}{4}$	3,2	0,9	PHS 35-2TB45
48	5,95	5,73	B	1610	$\frac{1}{2}$	1 $\frac{5}{8}$	1	3 $\frac{5}{8}$	3,5	0,9	PHS 35-2TB48
54	6,66	6,45	B	1610	$\frac{1}{2}$	1 $\frac{5}{8}$	1	3 $\frac{5}{8}$	3,9	0,9	PHS 35-2TB54
60	7,38	7,17	B	1610	$\frac{1}{2}$	1 $\frac{5}{8}$	1	3 $\frac{5}{8}$	4,9	0,9	PHS 35-2TB60
70	8,57	8,36	B	1610	$\frac{1}{2}$	1 $\frac{5}{8}$	1	3 $\frac{5}{8}$	6,3	0,9	PHS 35-2TB70
80	9,77	9,55	B	1610	$\frac{1}{2}$	1 $\frac{5}{8}$	1	3 $\frac{5}{8}$	7,9	0,9	PHS 35-2TB80
96	11,68	11,46	B	1610	$\frac{1}{2}$	1 $\frac{5}{8}$	1	3 $\frac{5}{8}$	9,9	0,9	PHS 35-2TB96
112	13,59	13,37	B	1610	$\frac{1}{2}$	1 $\frac{5}{8}$	1	3 $\frac{5}{8}$	10,9	0,9	PHS 35-2TB112

For hardened teeth sprockets, add "H" after the sprocket profile e.g. PHS 08B-1AH8.

Type B

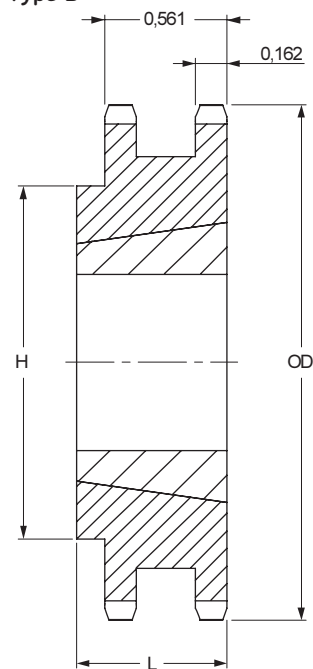



ANSI sprockets

Duplex

Taper Bushed

- ▶ Belts
- ▶ Chains
- ▶ Couplings
- ▶ Bushings and Hubs
- ▶ Sprockets
- ▶ Pulleys
- ▶ Smart tools

ANSI 40-2 1/2" Pitch

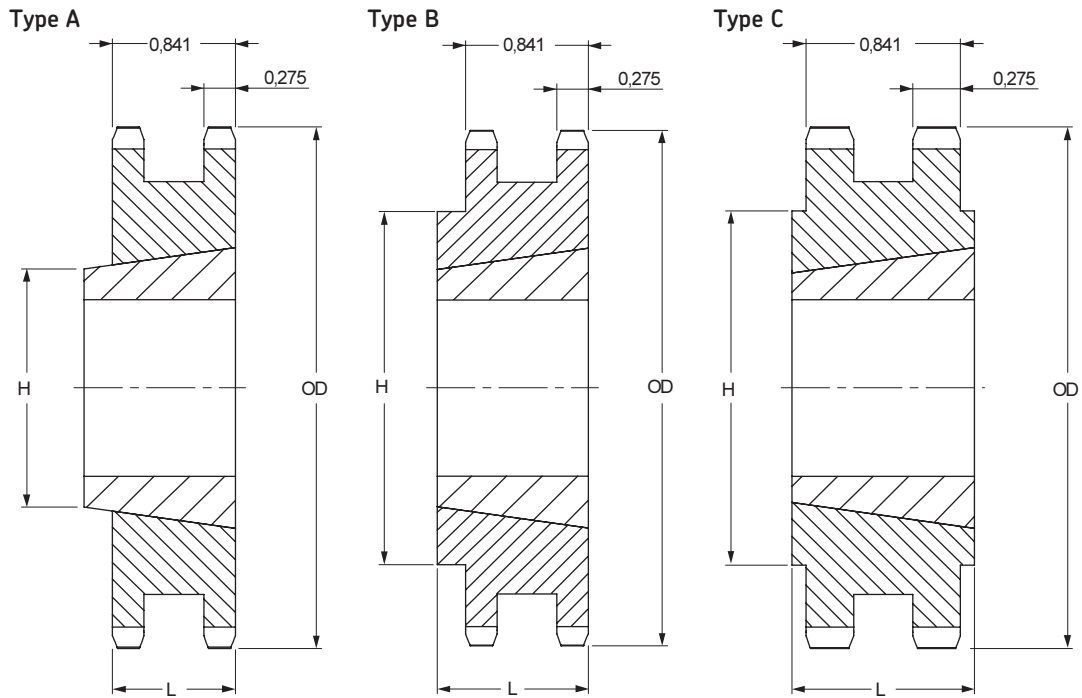

Taper Bushed Type A/B/C

No. Teeth	Diameter		Type	Bushing Number	Bore		Dimensions		Weight		Designation
	Outside	Pitch			Min	Max	L	H	Rim	Bushing	
	Inch	Inch			Inch	Inch	Inch	Inch	lbs	lbs	
15	2,65	2,40	A	1008	$\frac{3}{8}$	1	$\frac{7}{8}$	1 $\frac{17}{64}$	0,5	0,3	PHS 40-2TB15
16	2,81	2,56	A	1008	$\frac{3}{8}$	1	$\frac{7}{8}$	1 $\frac{17}{64}$	0,6	0,3	PHS 40-2TB16
17	2,98	2,72	A	1008	$\frac{3}{8}$	1	$\frac{7}{8}$	1 $\frac{17}{64}$	0,7	0,3	PHS 40-2TB17
18	3,13	2,88	B	1210	$\frac{5}{8}$	1 $\frac{1}{4}$	1	2 $\frac{3}{16}$	0,7	0,6	PHS 40-2TB18
19	3,30	3,04	B	1210	$\frac{5}{8}$	1 $\frac{1}{4}$	1	2 $\frac{3}{16}$	0,9	0,6	PHS 40-2TB19
20	3,46	3,20	B	1610	$\frac{1}{2}$	1 $\frac{5}{8}$	1	2 $\frac{5}{8}$	0,9	0,9	PHS 40-2TB20
21	3,62	3,36	B	1610	$\frac{1}{2}$	1 $\frac{5}{8}$	1	2 $\frac{3}{4}$	1,0	0,9	PHS 40-2TB21
23	3,94	3,67	B	1610	$\frac{1}{2}$	1 $\frac{5}{8}$	1	3	1,3	0,9	PHS 40-2TB23
25	4,26	3,99	B	2012	$\frac{3}{4}$	2	1 $\frac{1}{4}$	3 $\frac{13}{32}$	1,6	1,7	PHS 40-2TB25
30	5,06	4,78	B	2012	$\frac{3}{4}$	2	1 $\frac{1}{4}$	4 $\frac{15}{64}$	3,4	1,7	PHS 40-2TB30
36	6,01	5,74	B	2012	$\frac{3}{4}$	2	1 $\frac{1}{4}$	5 $\frac{5}{32}$	5,9	1,7	PHS 40-2TB36
42	6,97	6,69	C	2517	$\frac{3}{4}$	2 $\frac{1}{2}$	1 $\frac{3}{4}$	4 $\frac{1}{4}$	7,0	3,5	PHS 40-2TB42
48	7,93	7,64	C	2517	$\frac{3}{4}$	2 $\frac{1}{2}$	1 $\frac{3}{4}$	4 $\frac{1}{4}$	9,6	3,5	PHS 40-2TB48
52	8,57	8,28	C	2517	$\frac{3}{4}$	2 $\frac{1}{2}$	1 $\frac{3}{4}$	4 $\frac{1}{4}$	11,4	3,5	PHS 40-2TB52
60	9,84	9,55	C	2517	$\frac{3}{4}$	2 $\frac{1}{2}$	1 $\frac{3}{4}$	4 $\frac{1}{4}$	15,4	3,5	PHS 40-2TB60
68	11,12	10,83	C	2517	$\frac{3}{4}$	2 $\frac{1}{2}$	1 $\frac{3}{4}$	4 $\frac{1}{4}$	20,5	3,5	PHS 40-2TB68
76	12,39	12,10	C	2517	$\frac{3}{4}$	2 $\frac{1}{2}$	1 $\frac{3}{4}$	4 $\frac{1}{4}$	25,7	3,5	PHS 40-2TB76
84	13,66	13,37	C	2517	$\frac{3}{4}$	2 $\frac{1}{2}$	1 $\frac{3}{4}$	4 $\frac{1}{4}$	31,6	3,5	PHS 40-2TB84
95	15,41	15,12	C	2517	$\frac{3}{4}$	2 $\frac{1}{2}$	1 $\frac{3}{4}$	4 $\frac{1}{4}$	34,1	3,5	PHS 40-2TB95
102	16,53	16,24	C	2517	$\frac{3}{4}$	2 $\frac{1}{2}$	1 $\frac{3}{4}$	4 $\frac{1}{4}$	36,8	3,5	PHS 40-2TB102

For hardened teeth sprockets, add "H" after the sprocket profile e.g. PHS 08B-1AH8.

ANSI sprockets

Duplex
Taper Bushed



ANSI 50-2 5/8" Pitch

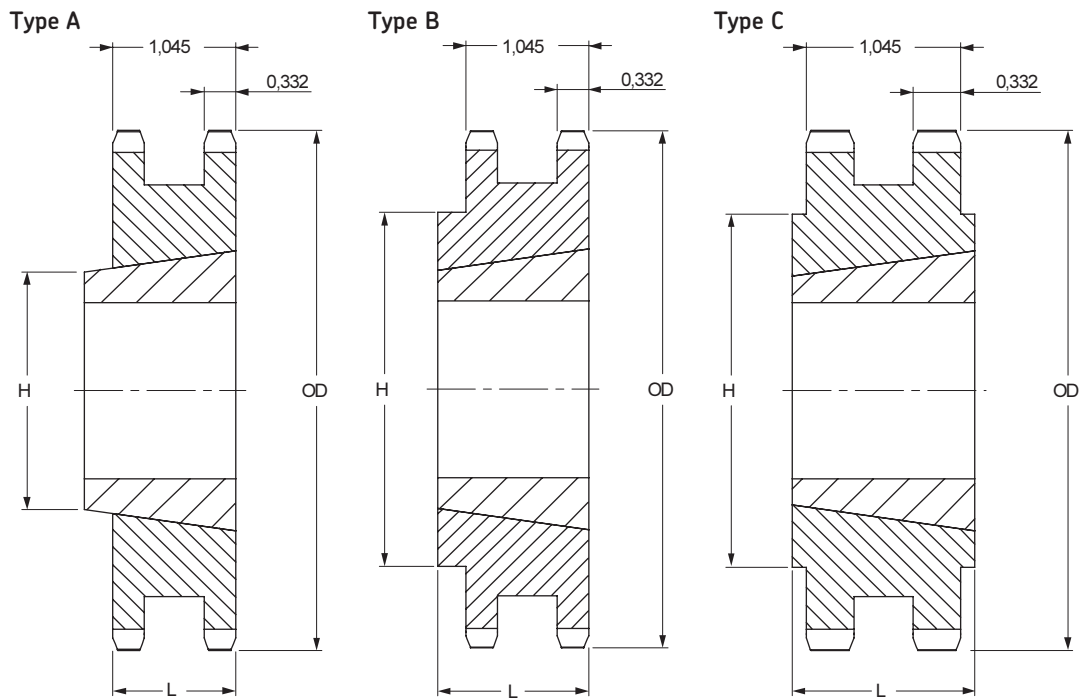

Taper Bushed Type A/B/C

No. Teeth	Diameter		Type	Bushing Number	Bore		Dimensions		Weight		Designation
	Outside	Pitch			Min	Max	L	H	Rim	Bushing	
	Inch	Inch			Inch	Inch	Inch	Inch	lbs	lbs	
14	3,11	2,81	A	1008	$\frac{3}{8}$	1	$\frac{7}{8}$	—	0,8	0,3	PHS 50-2TB14
15	3,31	3,01	A	1210	$\frac{5}{8}$	$1 \frac{1}{4}$	1	—	0,9	0,6	PHS 50-2TB15
16	3,52	3,20	A	1210	$\frac{5}{8}$	$1 \frac{1}{4}$	1	—	1,1	0,6	PHS 50-2TB16
17	3,72	3,41	A	1610	$\frac{1}{2}$	$1 \frac{5}{8}$	1	—	1,1	0,6	PHS 50-2TB17
18	3,92	3,60	A	1610	$\frac{1}{2}$	$1 \frac{5}{8}$	1	—	1,3	0,9	PHS 50-2TB18
19	4,12	3,80	A	1610	$\frac{1}{2}$	$1 \frac{5}{8}$	1	—	1,6	0,9	PHS 50-2TB19
20	4,32	4,00	B	2012	$\frac{3}{4}$	2	$1 \frac{1}{4}$	$3 \frac{1}{4}$	1,5	1,7	PHS 50-2TB20
21	4,52	4,19	B	2012	$\frac{3}{4}$	2	$1 \frac{1}{4}$	$3 \frac{1}{2}$	1,9	1,7	PHS 50-2TB21
25	5,32	4,99	B	2012	$\frac{3}{4}$	2	$1 \frac{1}{4}$	$4 \frac{9}{32}$	3,8	1,7	PHS 50-2TB25
30	6,32	5,98	B	2517	$\frac{3}{4}$	$2 \frac{1}{2}$	$1 \frac{3}{4}$	$5 \frac{9}{32}$	7,5	3,5	PHS 50-2TB30
36	7,52	7,17	C	2517	$\frac{3}{4}$	$2 \frac{1}{2}$	$1 \frac{3}{4}$	$4 \frac{1}{4}$	9,4	3,5	PHS 50-2TB36
42	8,71	8,36	C	2517	$\frac{3}{4}$	$2 \frac{1}{2}$	$1 \frac{3}{4}$	$4 \frac{1}{4}$	13,4	3,5	PHS 50-2TB42
48	9,91	9,56	C	2517	$\frac{3}{4}$	$2 \frac{1}{2}$	$1 \frac{3}{4}$	$4 \frac{1}{4}$	18,6	3,5	PHS 50-2TB48
52	10,71	10,35	C	2517	$\frac{3}{4}$	$2 \frac{1}{2}$	$1 \frac{3}{4}$	$4 \frac{3}{8}$	22,2	3,5	PHS 50-2TB52
60	12,30	11,94	C	2517	$\frac{3}{4}$	$2 \frac{1}{2}$	$1 \frac{3}{4}$	$4 \frac{3}{8}$	30,3	3,5	PHS 50-2TB60
68	13,89	13,53	C	2517	$\frac{3}{4}$	$2 \frac{1}{2}$	$1 \frac{3}{4}$	$4 \frac{3}{8}$	39,4	3,5	PHS 50-2TB68
76	15,49	15,12	C	2517	$\frac{3}{4}$	$2 \frac{1}{2}$	$1 \frac{3}{4}$	$4 \frac{3}{8}$	41,2	3,5	PHS 50-2TB76
84	17,08	16,71	C	2517	$\frac{3}{4}$	$2 \frac{1}{2}$	$1 \frac{3}{4}$	$4 \frac{3}{8}$	45,3	3,5	PHS 50-2TB84
95	19,27	18,90	C	2517	$\frac{3}{4}$	$2 \frac{1}{2}$	$1 \frac{3}{4}$	$4 \frac{3}{8}$	58,8	3,5	PHS 50-2TB95
102	20,66	20,30	C	2517	$\frac{3}{4}$	$2 \frac{1}{2}$	$1 \frac{3}{4}$	$4 \frac{3}{8}$	67,1	3,5	PHS 50-2TB102

For hardened teeth sprockets, add "H" after the sprocket profile e.g. PHS 08B-1AH8.



ANSI sprockets

Duplex

Taper Bushed

- ▶ Belts
- ▶ Chains
- ▶ Couplings
- ▶ Bushings and Hubs
- ▶ Sprockets
- ▶ Pulleys
- ▶ Smart tools

ANSI 60-2 3/4" Pitch

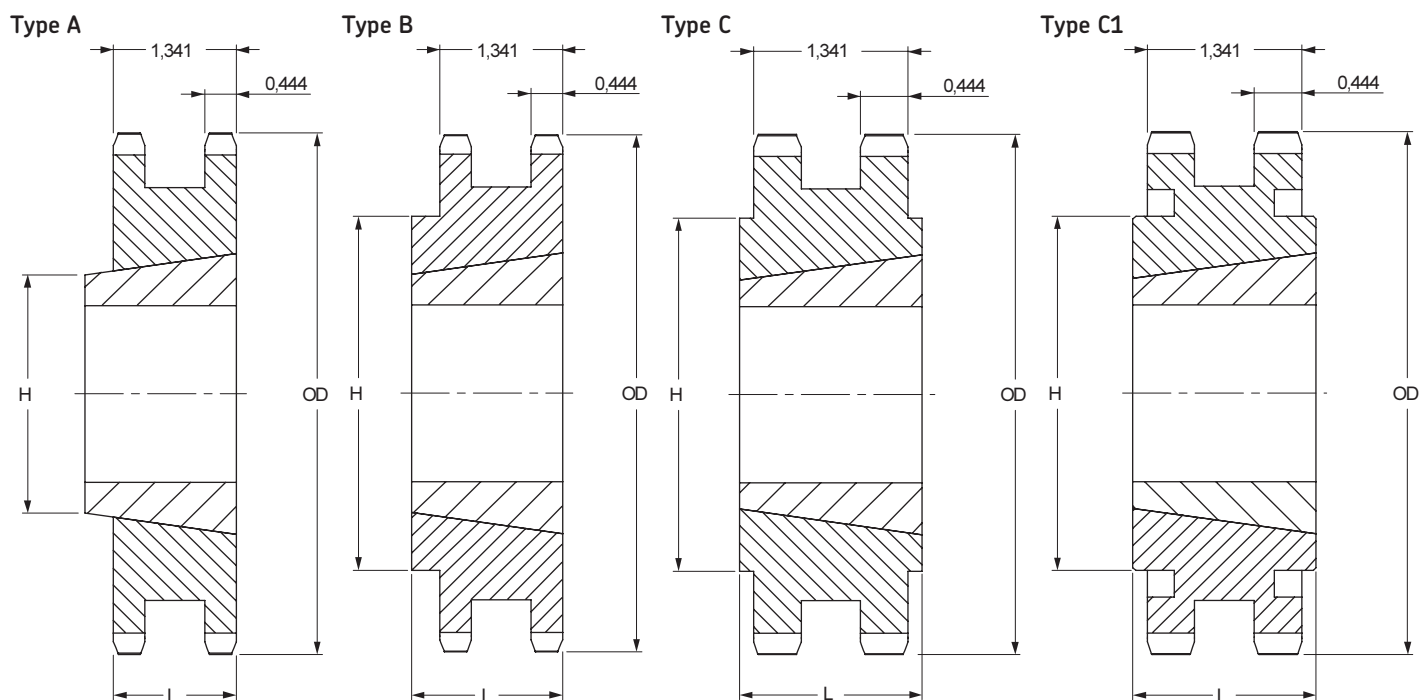

Taper Bushed Type A/B/C/C1

No. Teeth	Diameter		Type	Bushing Number	Bore		Dimensions		Weight		Designation
	Outside	Pitch			Min	Max	L	H	Rim	Bushing	
	Inch	Inch			Inch	Inch	Inch	Inch	lbs	lbs	
13	3,49	3,13	B	1215	5/8	1 1/4	1 1/2	2 1/4	1,2	1,6	PHS 60-2TB13
14	3,74	3,37	B	1215	5/8	1 3/4	1 1/2	2 1/2	1,6	1,7	PHS 60-2TB14
15	3,98	3,61	B	1615	1/2	1 5/8	1 1/2	2 13/16	1,3	1,8	PHS 60-2TB15
16	4,22	3,84	B	1615	1/2	1 5/8	1 1/2	3	2,2	2,3	PHS 60-2TB16
17	4,46	4,08	B	1615	1/2	1 5/8	1 1/2	3 1/4	2,5	2,8	PHS 60-2TB17
18	4,70	4,32	A	2012	3/4	2	1 1/4	-	3,0	2,4	PHS 60-2TB18
19	4,95	4,56	A	2012	3/4	2	1 1/4	-	3,5	2,9	PHS 60-2TB19
20	5,18	4,79	B	2517	3/4	1 1/2	1 3/4	3 61/64	4,0	2,9	PHS 60-2TB20
21	5,43	5,03	B	2517	3/4	1 1/2	1 3/4	4 3/16	5,0	3,8	PHS 60-2TB21
25	6,39	4,98	B	2517	3/4	1 1/2	1 3/4	5 3/32	7,5	7,4	PHS 60-2TB25
30	7,59	7,17	B	2517	3/4	1 1/2	1 3/4	6 11/32	13,5	13,3	PHS 60-2TB30
36	9,02	8,61	C	2517	3/4	1 1/2	1 3/4	4 3/4	17,5	17,4	PHS 60-2TB36
42	10,46	10,04	C	2517	3/4	1 1/2	1 3/4	4 3/4	25,5	25,0	PHS 60-2TB42
45	11,18	10,75	C	2517	3/4	1 1/2	1 3/4	4 3/4	29,5	29,3	PHS 60-2TB45
52	12,85	12,42	C	2517	3/4	1 1/2	1 3/4	4 3/4	41,0	40,3	PHS 60-2TB52
60	14,76	14,33	C1	2517	3/4	1 1/2	1 3/4	4 3/4	32,5	33,5	PHS 60-2TB60
68	16,67	16,24	C1	2517	3/4	1 1/2	1 3/4	4 1/2	36,5	43,2	PHS 60-2TB68
76	18,58	18,15	C1	3020	1 1/4	3	2	5 1/4	42,5	47,8	PHS 60-2TB76
95	23,12	22,68	C1	3020	1 1/4	3	2	5 1/4	48,5	69,8	PHS 60-2TB95

For hardened teeth sprockets, add "H" after the sprocket profile e.g. PHS 08B-1AH8.

ANSI sprockets

Duplex
Taper Bushed



ANSI 80-2 1" Pitch

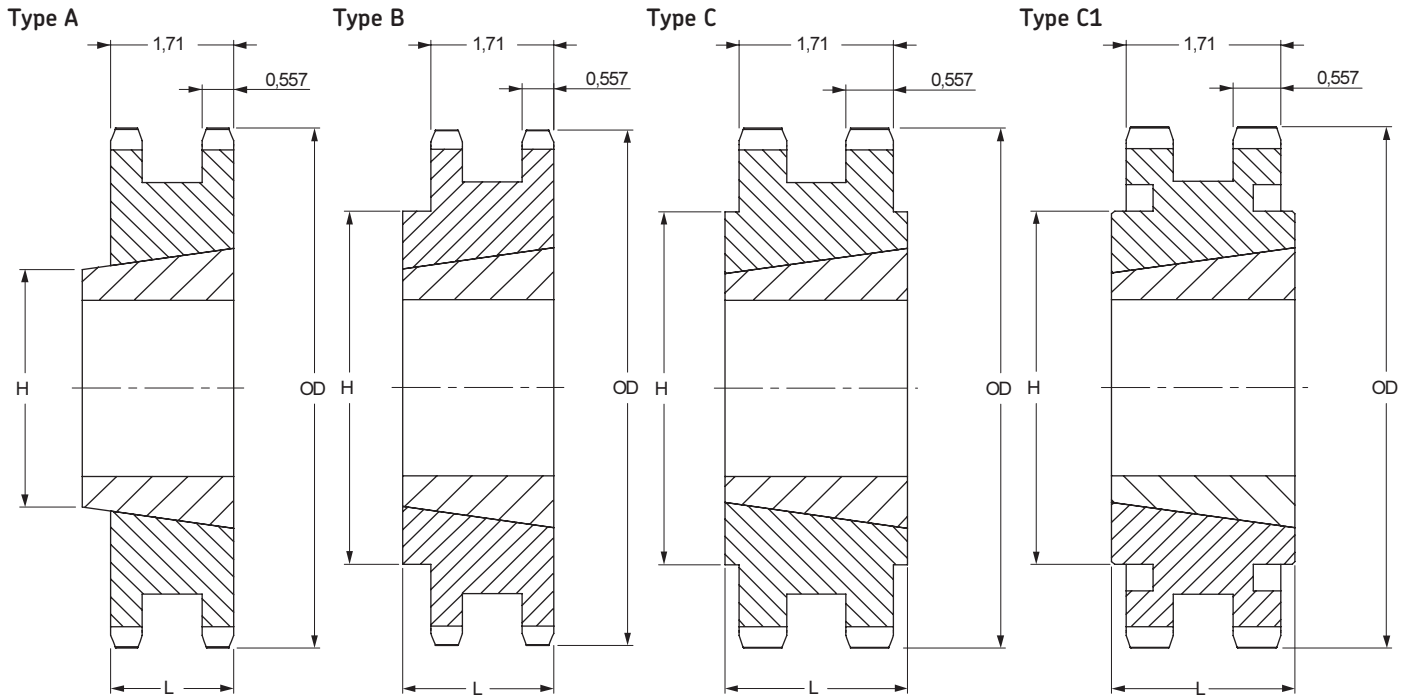

Taper Bushed Type A/B/C/C1

No. Teeth	Diameter		Type	Bushing Number	Bore		Dimensions		Weight		Designation
	Outside	Pitch			Min	Max	L	H	Rim	Bushing	
13	4,66	4,18	A	1615	1/2	1 5/8	1 1/2	-	3,4	1,2	PHS 80-2TB13
14	4,98	4,49	A	2012	3/4	2	1 1/4	-	3,5	1,7	PHS 80-2TB14
15	5,30	4,81	A	2012	3/4	2	1 1/4	-	4,3	1,7	PHS 80-2TB15
16	5,63	5,13	A	2517	3/4	2 1/2	1 3/4	3 1/8	3,8	3,5	PHS 80-2TB16
17	5,95	5,44	A	2517	3/4	2 1/2	1 3/4	3 1/8	5,1	3,5	PHS 80-2TB17
18	6,27	5,76	A	2517	3/4	2 1/2	1 3/4	3 1/8	6,4	3,5	PHS 80-2TB18
19	6,59	6,08	B	3020	1 1/4	3	2	5	5,6	6,5	PHS 80-2TB19
20	6,91	6,39	B	3020	1 1/4	3	2	5 1/4	7,1	6,5	PHS 80-2TB20
21	7,24	6,71	B	3020	1 1/4	3	2	5 9/16	8,9	6,5	PHS 80-2TB21
25	8,52	7,98	B	3020	1 1/4	3	2	6 7/8	16,5	6,5	PHS 80-2TB25
30	10,11	9,57	C	3020	1 1/4	3	2	5 1/4	25,1	6,5	PHS 80-2TB30
36	12,03	11,47	C	3020	1 3/4	3	2	5 1/4	39,4	6,5	PHS 80-2TB36
42	13,94	13,39	C	3020	1 3/4	3	2	5 1/4	36,4	6,5	PHS 80-2TB42
45	14,90	14,34	C1	3020	1 3/4	3	2	5 1/4	41,4	6,5	PHS 80-2TB45
52	17,13	16,56	C1	3020	1 3/4	3	2	5 1/4	56,2	6,5	PHS 80-2TB52
60	19,68	19,11	C1	3020	1 3/4	3	2	5 1/4	66,3	6,5	PHS 80-2TB60
68	22,23	21,65	C1	3020	1 3/4	3	2	5 1/4	72,0	6,5	PHS 80-2TB68
76	24,78	24,20	C1	3020	1 3/4	3	2	5 1/4	89,1	6,5	PHS 80-2TB76
95	30,83	30,25	C1	3020	1 3/4	3	2	5 1/4	112,0	6,5	PHS 80-2TB95

For hardened teeth sprockets, add "H" after the sprocket profile e.g. PHS 08B-1AH8.



ANSI sprockets

Triplex
Pilot Bore

- ▶ Belts
- ▶ Chains
- ▶ Couplings
- ▶ Bushings and Hubs
- ▶ Sprockets
- ▶ Pulleys
- ▶ Smart tools

ANSI 35-3 3/8" Pitch

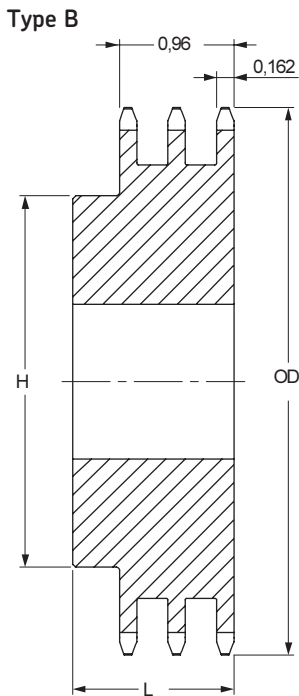

ANSI 40-3 1/2" Pitch

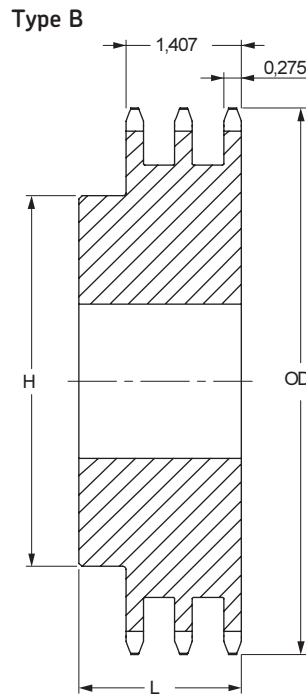

Pilot Bore Type B

No. Teeth	Outside Diameter	Type	Bore		Hub		Weight	Designation
			Min	Max	H	L		
			Inch	Inch	Inch	Inch		
13	1.75	B	1/2	11/16	1 7/64	1 3/4	0.5	PHS 35-3B13
14	1.87	B	1/2	7/8	1 3/4	1 3/4	0.6	PHS 35-3B14
15	1.99	B	1/2	15/16	1 13/32	1 3/4	0.8	PHS 35-3B15
17	2.23	B	1/2	11/16	1 29/32	1 3/4	1.0	PHS 35-3B17
18	2.35	B	1/2	13/16	1 23/32	1 3/4	1.2	PHS 35-3B18
20	2.59	B	3/4	15/16	1 15/16	1 7/8	1.5	PHS 35-3B20
21	2.71	B	3/4	1 3/8	2 1/16	1 7/8	1.7	PHS 35-3B21
22	2.83	B	3/4	1 7/16	2 3/16	1 7/8	2.0	PHS 35-3B22
23	2.95	B	3/4	1 1/2	2 1/4	1 7/8	2.1	PHS 35-3B23
24	3.07	B	3/4	1 1/2	2 1/4	1 7/8	2.3	PHS 35-3B24
25	3.19	B	3/4	1 1/2	2 1/4	1 7/8	2.4	PHS 35-3B25
26	3.31	B	3/4	1 1/2	2 1/2	1 7/8	2.8	PHS 35-3B26
30	3.79	B	3/4	1 3/4	2 1/2	1 7/8	3.4	PHS 35-3B30
36	4.51	B	3/4	1 3/4	2 1/2	1 7/8	4.5	PHS 35-3B36
42	5.23	B	3/4	1 3/4	2 1/2	1 7/8	5.9	PHS 35-3B42
48	5.95	B	3/4	1 3/4	2 1/2	1 7/8	7.4	PHS 35-3B48
52	6.43	B	3/4	1 3/4	2 1/2	1 7/8	8.5	PHS 35-3B52
60	7.38	B	3/4	1 3/4	2 1/2	1 7/8	11.2	PHS 35-3B60
68	8.34	B	3/4	2 3/8	3 1/2	1 7/8	15.4	PHS 35-3B68
72	8.81	B	3/4	2 3/8	3 1/2	1 7/8	17.3	PHS 35-3B72
76	9.29	B	3/4	2 3/8	3 1/2	1 7/8	18.9	PHS 35-3B76
84	10.25	B	1	2 3/8	3 1/2	1 7/8	22.8	PHS 35-3B84
95	11.56	B	1	2 1/2	3 3/4	2 1/8	29.3	PHS 35-3B95
96	11.68	B	1	2 1/2	3 3/4	2 1/8	30.1	PHS 35-3B96
102	12.40	B	1	2 1/2	3 3/4	2 1/8	33.4	PHS 35-3B102
16	2.11	B	1/2	15/16	1 13/32	1 3/4	0.8	PHS 35-3B16
19	2.47	B	1/2	15/16	1 7/8	1 3/4	1.4	PHS 35-3B19

Maximum bores can accommodate standard keyways. Larger bores are available where a shallow keyway is used or no keyway is required. For hardened teeth sprockets, add "H" after the sprocket profile e.g. PHS 08B-1AH8.

Pilot Bore Type B

No. Teeth	Outside Diameter	Type	Bore		Hub		Weight	Designation
			Min	Max	H	L		
			Inch	Inch	Inch	Inch		
11	2.00	B	1/2	3/4	1 7/16	2 1/8	0.8	PHS 40-3B11
12	2.17	B	3/2	15/16	1 3/16	2 1/8	1.1	PHS 40-3B12
13	2.33	B	1/2	1	1 1/2	2 1/8	1.2	PHS 40-3B13
14	2.49	B	1/2	1 1/8	1 13/16	2 1/8	1.5	PHS 40-3B14
15	2.65	B	1/2	1 1/4	1 13/16	2 1/8	1.8	PHS 40-3B15
16	2.81	B	5/8	1 3/8	2	2 1/8	2.0	PHS 40-3B16
19	3.30	B	5/8	1 3/4	2 1/2	2 1/8	3.1	PHS 40-3B19
20	3.46	B	5/8	1 7/8	2 5/8	2 1/4	3.7	PHS 40-3B20
22	3.78	B	5/8	1 7/8	2 7/8	2 1/4	4.5	PHS 40-3B22
23	3.94	B	5/8	2	3	2 1/4	5.0	PHS 40-3B23
24	4.10	B	5/8	2 1/4	3 1/4	2 1/4	5.6	PHS 40-3B24
25	4.26	B	5/8	2 1/4	3 3/4	2 1/4	6.0	PHS 40-3B25
26	4.42	B	5/8	2 1/4	3 3/4	2 1/4	6.4	PHS 40-3B26
30	5.06	B	7/8	2 1/4	3 3/4	2 1/4	7.8	PHS 40-3B30
35	5.86	B	7/8	2 1/4	3 3/4	2 1/4	10.3	PHS 40-3B35
36	6.02	B	15/16	2 1/2	3 3/4	2 3/8	11.7	PHS 40-3B36
42	6.97	B	15/16	2 1/2	3 3/4	2 3/8	15.4	PHS 40-3B42
48	7.93	B	15/16	2 1/2	3 3/4	2 3/8	19.4	PHS 40-3B48
52	8.57	B	15/16	2 1/2	3 3/4	2 3/8	22.4	PHS 40-3B52
60	9.84	B	15/16	2 1/2	3 3/4	2 3/8	30.0	PHS 40-3B60
68	11.12	B	1 1/16	2 3/4	4	2 5/8	38.4	PHS 40-3B68
95	15.41	B	1 3/16	2 3/4	4 1/4	2 3/4	62.2	PHS 40-3B95
17	2.98	B	5/8	1 7/16	2 1/8	2 1/8	2.3	PHS 40-3B17
18	3.14	B	5/8	1 1/2	2 1/8	2 1/8	2.7	PHS 40-3B18
21	3.62	B	5/8	1 7/8	2 3/4	2 1/8	4.1	PHS 40-3B21
72	11.75	B	1 3/16	2 3/4	4	2 5/8	42.5	PHS 40-3B72
76	12.39	B	1 3/16	2 3/4	4	2 5/8	46.9	PHS 40-3B76
84	13.66	B	1 3/16	2 3/4	4 1/4	2 5/8	57.3	PHS 40-3B84
102	16.53	B	1 3/16	2 3/4	4 1/4	2 3/4	68.4	PHS 40-3B102

Maximum bores can accommodate standard keyways. Larger bores are available where a shallow keyway is used or no keyway is required. For hardened teeth sprockets, add "H" after the sprocket profile e.g. PHS 08B-1AH8.



ANSI sprockets

Triplex
Pilot Bore



ANSI 50-3 5/8" Pitch

ANSI 60-3 3/4" Pitch

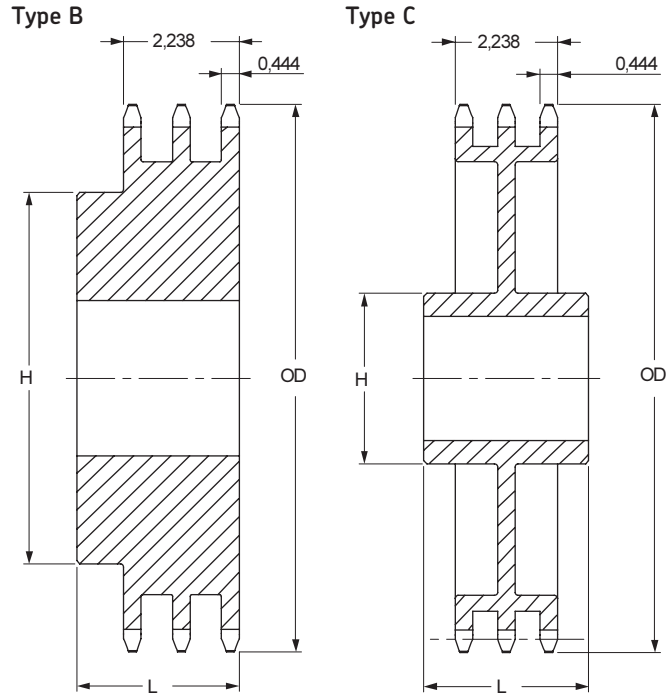
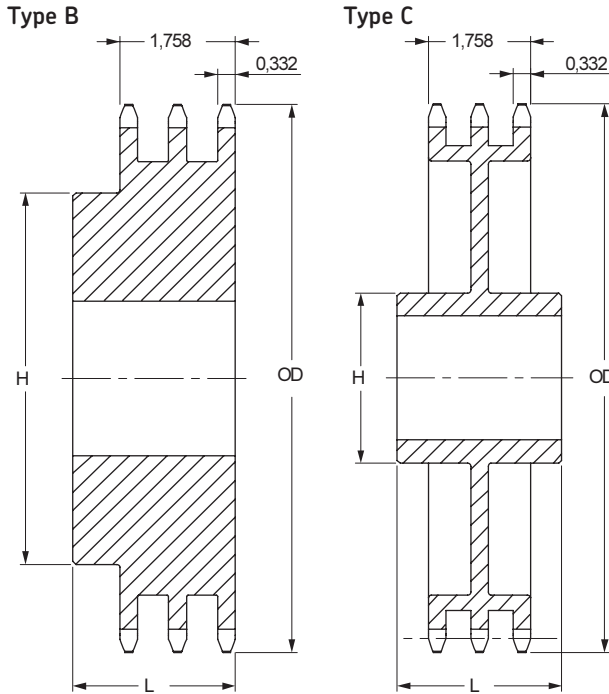

Pilot Bore Type B/C

Pilot Bore Type B/C

No. Teeth	Outside Diameter	Type	Bore		Hub		Weight	Designation
			Min	Max	H	L		
			Inch	Inch	Inch	Inch		
11	2,50	B	5/8	15/16	1 15/32	2 1/2	1,4	PHS 50-3B11
12	2,71	B	5/8	1 1/8	1 11/16	2 1/2	1,8	PHS 50-3B12
13	2,91	B	5/8	1 1/16	1 7/8	2 1/2	2,3	PHS 50-3B13
14	3,11	B	5/8	1 3/8	2 1/16	2 1/2	2,7	PHS 50-3B14
15	3,32	B	3/4	1 1/2	2 5/16	2 1/2	3,2	PHS 50-3B15
16	3,52	B	3/4	1 3/4	2 1/2	2 1/2	3,8	PHS 50-3B16
17	3,72	B	3/4	1 7/8	2 11/16	2 1/2	4,4	PHS 50-3B17
18	3,92	B	3/4	1 15/16	2 15/16	2 1/2	5,1	PHS 50-3B18
19	4,12	B	1	2 1/8	3 1/8	2 1/2	5,6	PHS 50-3B19
20	4,32	B	1	2 1/4	3 3/4	2 5/8	6,4	PHS 50-3B20
21	4,52	B	1	2 3/8	3 1/2	2 5/8	7,4	PHS 50-3B21
22	4,72	B	1	2 3/8	3 9/16	2 5/8	7,9	PHS 50-3B22
23	4,92	B	1	2 1/2	3 5/8	2 5/8	8,8	PHS 50-3B23
24	5,12	B	1	2 1/2	3 5/8	2 5/8	9,4	PHS 50-3B24
25	5,32	B	1	2 1/2	3 5/8	2 5/8	10,2	PHS 50-3B25
26	5,52	B	1	2 1/2	3 3/4	2 5/8	11,0	PHS 50-3B26
30	6,32	B	1	2 1/2	3 3/4	2 5/8	14,2	PHS 50-3B30
35	7,32	B	1	2 1/2	3 3/4	2 5/8	19,0	PHS 50-3B35
36	7,52	B	1 3/16	2 3/4	4	2 3/4	20,6	PHS 50-3B36
42	8,72	B	1 3/16	2 3/4	4	2 3/4	27,5	PHS 50-3B42
48	9,91	B	1 3/16	2 3/4	4	3 1/8	36,6	PHS 50-3B48
52	10,71	B	1 3/16	2 3/4	4	3 1/8	42,5	PHS 50-3B52
60	12,30	B	1 5/16	3	4 1/2	3 1/8	56,8	PHS 50-3B60
68	13,89	B	1 5/16	3	4 1/2	3 1/8	73,2	PHS 50-3B68
72	14,69	C	1 3/16	3	4 3/4	3 1/2	54,4	PHS 50-3C72
76	15,49	C	1 3/16	3	4 3/4	3 1/2	51,2	PHS 50-3C76
84	17,08	C	1 3/16	3	4 3/4	3 1/2	65,3	PHS 50-3C84
95	19,27	C	1 5/16	3	4 3/4	3 1/4	74,4	PHS 50-3C95
102	20,66	C	1 5/16	3	4 3/4	3 1/4	79,9	PHS 50-3C102

No. Teeth	Outside Diameter	Type	Bore		Hub		Weight	Designation
			Min	Max	H	L		
			Inch	Inch	Inch	Inch		
11	3,00	B	1	1 1/4	1 13/16	3	2,5	PHS 60-3B11
13	3,49	B	1	1 1/2	2 1/4	3	3,9	PHS 60-3B13
14	3,74	B	1	1 1/4	2 1/2	3	4,5	PHS 60-3B14
15	3,98	B	1	1 7/8	2 13/16	3	5,4	PHS 60-3B15
16	4,22	B	1	2	3	3	6,5	PHS 60-3B16
18	4,70	B	1	2 3/8	3 1/2	3	8,5	PHS 60-3B18
19	4,95	B	1	2 1/2	3 13/16	3	10,0	PHS 60-3B19
20	5,19	B	1	2 1/2	3 3/4	3	11,2	PHS 60-3B20
21	5,43	B	1	2 3/4	4 1/8	3	12,5	PHS 60-3B21
22	5,67	B	1	2 3/4	4 1/4	3	13,2	PHS 60-3B22
23	5,91	B	1	2 3/4	4 1/4	3	14,6	PHS 60-3B23
25	6,39	B	1	2 3/4	4 1/4	3	17,0	PHS 60-3B25
30	7,59	B	1	2 3/4	4 1/4	3	23,2	PHS 60-3B30
35	8,78	B	1 1/4	3	4 1/2	3 1/4	34,5	PHS 60-3B35
42	10,46	B	1 1/4	3 1/4	4 3/4	3 5/8	49,0	PHS 60-3B42
45	11,18	B	1 1/4	3 1/4	4 3/4	3 5/8	57,0	PHS 60-3B45
52	12,85	C	1 1/4	3 1/4	4 3/4	3 1/2	73,0	PHS 60-3C52
60	14,76	C	1 1/4	3 1/4	4 3/4	3 1/2	63,0	PHS 60-3C60
68	16,67	C	1 1/4	3 1/4	5	3 1/2	73,0	PHS 60-3C68
72	17,63	C	1 1/4	3 1/4	5	3 1/2	85,0	PHS 60-3C72
76	18,58	C	1 1/2	3 3/4	5 1/2	3 1/2	82,0	PHS 60-3C76
12	3,25	B	1	1 7/16	2 1/8	3	3,3	PHS 60-3B12
17	4,46	B	1	2 1/4	3 1/4	3	7,7	PHS 60-3B17
24	6,15	B	1	2 3/4	4 1/4	3	15,8	PHS 60-3B24
26	6,63	B	1	2 3/4	4 1/4	3	18,6	PHS 60-3B26
36	9,02	B	1 1/4	3	4 1/2	3 1/4	37,0	PHS 60-3B36
95	23,12	C	1 1/2	3 3/4	5 1/2	4	105,0	PHS 60-3C95

Maximum bores can accommodate standard keyways. Larger bores are available where a shallow keyway is used or no keyway is required. For hardened teeth sprockets, add "H" after the sprocket profile e.g. PHS 08B-1AH8.

Maximum bores can accommodate standard keyways. Larger bores are available where a shallow keyway is used or no keyway is required. For hardened teeth sprockets, add "H" after the sprocket profile e.g. PHS 08B-1AH8.

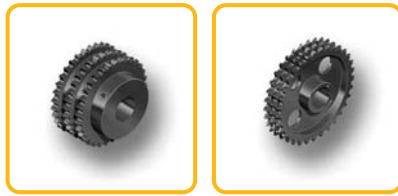

ANSI sprockets

Triplex
Pilot Bore

- ▶ Belts
- ▶ Chains
- ▶ Couplings
- ▶ Bushings and Hubs
- ▶ Sprockets
- ▶ Pulleys
- ▶ Smart tools

ANSI 80-3 1" Pitch

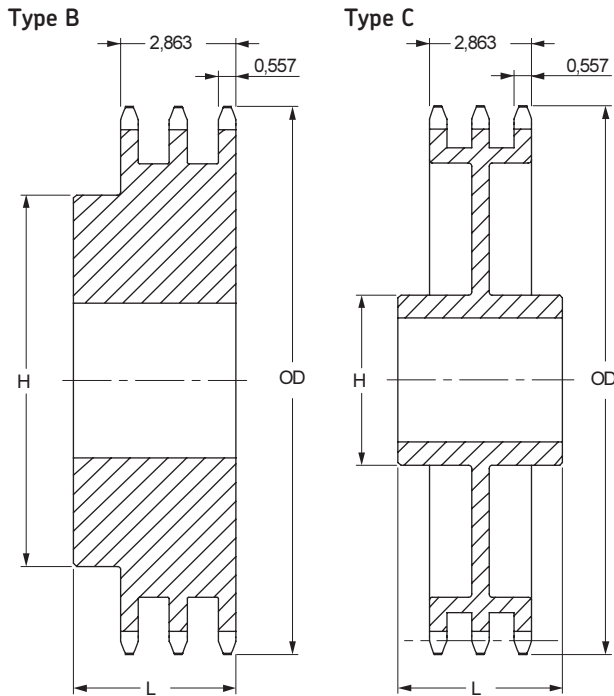

ANSI 100-3 1 1/4" Pitch

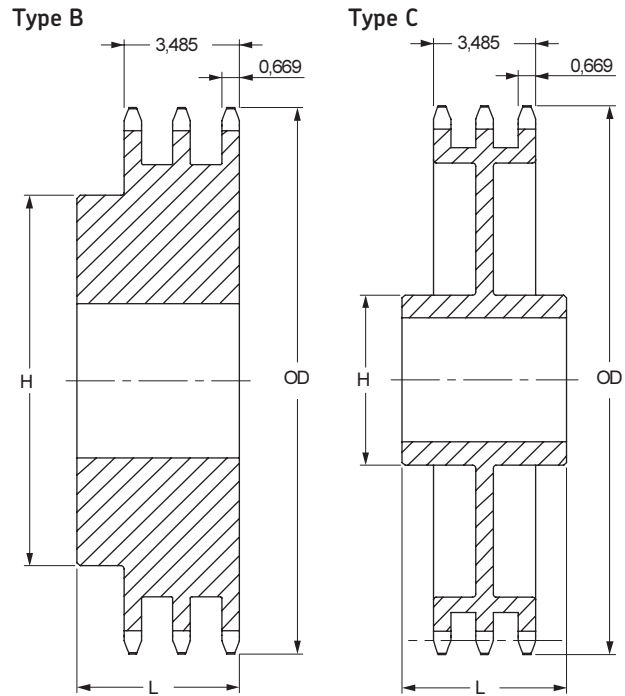

Pilot Bore Type B/C

No. Teeth	Outside Diameter	Type	Bore		Hub		Weight	Designation
			Min	Max	H	L		
			Inch	Inch	Inch	Inch		
11	4,01	B	1	3/4	2 1/2	3 5/8	5,9	PHS 80-3B11
12	4,33	B	1	7/8	2 27/32	3 5/8	7,5	PHS 80-3B12
13	4,66	B	1	2 1/4	3 5/32	3 5/8	9,2	PHS 80-3B13
14	4,98	B	1	2 3/8	3 13/32	3 5/8	11,0	PHS 80-3B14
15	5,30	B	1	2 1/2	3 51/64	3 5/8	13,1	PHS 80-3B15
16	5,63	B	1	2 3/4	4	3 7/8	15,8	PHS 80-3B16
17	5,95	B	1	3	4 27/64	3 7/8	18,6	PHS 80-3B17
18	6,27	B	1	3 1/4	4 47/64	3 7/8	21,2	PHS 80-3B18
19	6,59	B	1	3 5/16	5	3 7/8	23,7	PHS 80-3B19
20	6,91	B	1	3 3/16	5	3 7/8	26,0	PHS 80-3B20
21	7,24	B	1	3 1/16	5	3 7/8	28,4	PHS 80-3B21
22	7,56	B	1	3 5/16	5	3 7/8	31,0	PHS 80-3B22
23	7,88	B	1	3 1/16	5	3 7/8	33,6	PHS 80-3B23
24	8,20	B	1	3 1/2	5 1/4	3 7/8	37,1	PHS 80-3B24
25	8,52	B	1	3 1/2	5 1/4	3 7/8	40,1	PHS 80-3B25
26	8,84	B	1	3 3/2	5 1/4	3 7/8	42,9	PHS 80-3B26
30	10,11	B	1 3/4	3 3/4	5 3/4	4 1/4	54,5	PHS 80-3B30
35	11,71	B	1 3/4	3 3/4	5 3/4	4 1/4	79,5	PHS 80-3B35
36	12,03	B	1 3/4	3 3/4	5 3/4	4 1/4	83,9	PHS 80-3B36
42	13,94	C	1 3/4	3 13/16	6	4 1/2	84,9	PHS 80-3C42
45	14,90	C	1 3/4	3 13/16	6	4 1/2	92,4	PHS 80-3C45
52	17,13	C	1 3/2	3 13/16	6	4 1/2	107,0	PHS 80-3C52
60	19,68	C	1 1/2	4 1/4	6 1/4	4 3/4	128,0	PHS 80-3C60
68	22,23	C	1 1/2	4 1/4	6 1/4	4 3/4	140,0	PHS 80-3C68
76	24,78	C	1 1/2	4 1/4	6 1/4	4 3/4	165,0	PHS 80-3C76
95	30,83	C	1 1/2	4 1/2	6 3/4	5	240,0	PHS 80-3C95

Maximum bores can accommodate standard keyways. Larger bores are available where a shallow keyway is used or no keyway is required. For hardened teeth sprockets, add "H" after the sprocket profile e.g. PHS 08B-1AH8.

Pilot Bore Type B/C

No. Teeth	Outside Diameter	Type	Bore		Hub		Weight	Designation
			Min	Max	H	L		
			Inch	Inch	Inch	Inch		
11	5,01	B	1	2 1/8	3 1/8	4 1/4	11,7	PHS 100-3B11
12	5,42	B	1 1/8	2 1/4	3 3/8	4 1/4	13,7	PHS 100-3B12
13	5,82	B	1 1/8	2 1/2	3 13/16	4 1/4	16,9	PHS 100-3B13
14	6,23	B	1 1/8	2 3/4	4 3/16	4 1/4	20,2	PHS 100-3B14
15	6,63	B	1 1/4	3 1/8	4 5/8	4 1/2	25,0	PHS 100-3B15
16	7,03	B	1 1/4	3 5/16	5	4 1/2	29,3	PHS 100-3B16
17	7,44	B	1 1/4	3 1/2	5 1/4	4 1/2	33,8	PHS 100-3B17
18	7,84	B	1 1/4	3 1/2	5 1/4	4 3/4	38,6	PHS 100-3B18
19	8,24	B	1 1/4	3 3/4	5 1/2	4 3/4	43,3	PHS 100-3B19
20	8,64	B	1 1/4	3 3/4	5 1/2	4 3/4	47,9	PHS 100-3B20
21	9,04	B	1 1/4	3 3/4	5 1/2	4 3/4	52,3	PHS 100-3B21
22	9,44	B	1 1/4	3 3/4	5 1/2	4 3/4	57,5	PHS 100-3B22
23	9,84	B	1 1/4	3 3/4	5 1/2	4 3/4	62,5	PHS 100-3B23
24	10,25	B	1 1/4	3 3/4	5 1/2	4 3/4	69,0	PHS 100-3B24
25	10,65	B	1 1/4	3 3/4	5 1/2	4 3/4	73,0	PHS 100-3B25
26	11,05	B	1 1/2	3 13/16	5 3/4	4 3/4	79,0	PHS 100-3B26
30	12,64	B	1 1/2	3 13/16	5 3/4	4 3/4	103,0	PHS 100-3B30
35	14,64	C	1 1/2	4	6	5	108,0	PHS 100-3C35
45	18,63	C	1 1/2	4	6	5	143,0	PHS 100-3C45
60	24,60	C	1 1/2	5 3/8	7 1/2	5	217,0	PHS 100-3C60
70	28,58	C	1 1/2	5 3/8	7 1/2	5	262,0	PHS 100-3C70
80	32,57	C	1 1/2	5 3/8	7 1/2	5	313,0	PHS 100-3C80

Maximum bores can accommodate standard keyways. Larger bores are available where a shallow keyway is used or no keyway is required. For hardened teeth sprockets, add "H" after the sprocket profile e.g. PHS 08B-1AH8.

Pulleys





Pulleys

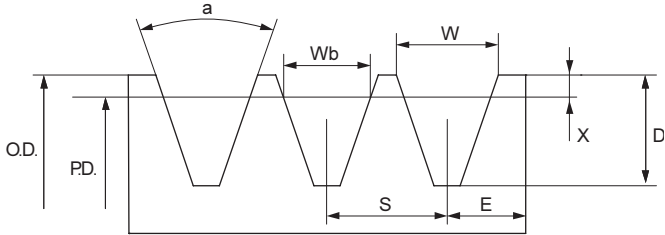

Wedge belt pulleys

Belt series	Pitch Diameter Range	Groove Angle		Dimensions				
		a	W	W _b	D	X	S	E
		°	mm	mm	mm	mm	mm	mm
SPZ	Up to 80	34°	9,7	8,5	11,0	2,00	12,0	8,0
	Over 80	38°	9,7	8,5	11,0	2,00	12,0	8,0
SPA	Up to 118	34°	12,7	11,0	13,8	2,75	15,0	10,0
	Over 118	38°	12,7	11,0	13,8	2,75	15,0	10,0
SPB	Up to 190	34°	16,2	14,0	17,5	3,50	19,0	12,5
	Over 190	38°	16,2	14,0	17,5	3,50	19,0	12,5
SPC	Up to 315	34°	22,0	19,0	23,8	4,80	25,5	17,0
	Over 315	38°	22,0	19,0	23,8	4,80	25,5	17,0

Classical V-belt pulleys

Belt series	Pitch Diameter Range	Groove Angle		Dimensions			
		a	W	W _b	D	X	S
		°	Inches	Inches	Inches	Inches	Inches
A-B	3,4 - 6,8	34°	0,612	0,625	0,175	0,750	0,500
	Over 6,8	38°	0,625	0,625	0,175	0,750	0,500
C	7,0 - 7,99	34°	0,879	0,780	0,200	1,000	0,688
	8,0 - 12,0	36°	0,887	0,780	0,200	1,000	0,688
	Over 12,0	38°	0,895	0,780	0,200	1,000	0,688
D	12,0 - 12,99	34°	1,259	1,050	0,300	1,438	0,875
	13,0 - 17,0	36°	1,271	1,050	0,300	1,438	0,875
	Over 17,0	38°	1,283	1,050	0,300	1,438	0,875
E	18,0 - 24,0	36°	1,527	1,300	0,400	1,750	1,230
	Over 24,0	38°	1,542	1,300	0,400	1,750	1,230

Narrow wedge belt pulleys

Belt series	Pitch Diameter Range	Groove Angle		Dimensions			
		a	W	W _b	D	X	S
		°	Inches	Inches	Inches	Inches	Inches
3V	Under 3,5	36°	0,350	0,350	0,025	0,407	0,344
	3,5 - 6	38°	0,350	0,350	0,025	0,407	0,344
	6,01 - 12	40°	0,350	0,350	0,025	0,407	0,344
	Over 12	42°	0,350	0,350	0,025	0,407	0,344
5V	Under 10	38°	0,600	0,050	0,050	0,688	0,500
	10 - 16	40°	0,600	0,050	0,050	0,688	0,500
	Over 16	42°	0,600	0,050	0,050	0,688	0,500
8V	Under 16	38°	1,000	1,000	0,100	1,125	0,750
	16 - 22,4	40°	1,000	1,000	0,100	1,125	0,750
	Over 22,4	42°	1,000	1,000	0,100	1,125	0,750



Wedge belt pulleys

SPZ taper bushed

- ▶ Belts
- ▶ Chains
- ▶ Couplings
- ▶ Bushings and Hubs
- ▶ Sprockets
- ▶ Pulleys
- ▶ Smart tools

1 Groove SPZ

Pitch Diameter	OD	Pulley Type	Bush No.	Bore		F	G	K	L	M	H	Weight*	Designation
				Min	Max								
mm	mm			mm	mm	mm	mm	mm	mm	mm	mm	kg	
50	54	9	1008	9	25	37	28	15,0	22	-	-	0,3	PHP 1SPZ50TB
56	60	9	1008	9	25	37	23	15,0	22	-	-	0,5	PHP 1SPZ56TB
60	64	9	1008	9	25	22	-	-	22	-	-	0,3	PHP 1SPZ60TB
63	67	1	1108	9	28	16	-	-	22	6,0	62	0,3	PHP 1SPZ63TB
67	71	1	1108	9	28	16	-	-	22	6,0	62	0,3	PHP 1SPZ67TB
71	75	1	1108	9	28	16	-	-	22	6,0	62	0,4	PHP 1SPZ71TB
75	79	1	1108	9	28	16	-	-	22	6,0	62	0,4	PHP 1SPZ75TB
80	84	1	1210	11	32	16	-	-	25	9,0	75	0,5	PHP 1SPZ80TB
85	89	1	1210	11	32	16	-	-	25	9,0	75	0,7	PHP 1SPZ85TB
90	94	1	1210	11	32	16	-	-	25	9,0	75	0,7	PHP 1SPZ90TB
95	99	1	1210	11	32	16	-	-	25	9,0	75	0,8	PHP 1SPZ95TB
100	104	1	1210	11	32	16	-	-	25	9,0	75	0,9	PHP 1SPZ100TB
106	110	1	1610	14	42	16	-	-	25	9,0	80	1,0	PHP 1SPZ106TB
112	116	1	1610	14	42	16	-	-	25	9,0	80	1,1	PHP 1SPZ112TB
118	122	1	1610	14	42	16	-	-	25	9,0	80	1,2	PHP 1SPZ118TB
125	129	1	1610	14	42	16	-	-	25	9,0	80	1,3	PHP 1SPZ125TB
132	136	1	1610	14	42	16	-	-	25	9,0	80	1,5	PHP 1SPZ132TB
140	144	1	1610	14	42	16	-	-	25	9,0	80	1,7	PHP 1SPZ140TB
150	154	1	1610	14	42	16	-	-	25	9,0	80	2,0	PHP 1SPZ150TB
160	164	1	1610	14	42	16	-	-	25	9,0	80	2,2	PHP 1SPZ160TB
170	174	1	1610	14	42	16	-	-	25	9,0	80	2,2	PHP 1SPZ170TB
180	184	1	1610	14	42	16	-	-	25	9,0	80	2,1	PHP 1SPZ180TB
190	194	8	1610	14	42	16	161	-	25	9,0	80	2,7	PHP 1SPZ190TB
200	204	8	2012	14	50	16	172	-	32	16,0	100	3,4	PHP 1SPZ200TB
224	228	8	2012	14	50	16	196	-	32	16,0	100	3,6	PHP 1SPZ224TB
250	254	4	2012	14	50	16	222	8,0	32	8,0	100	4,6	PHP 1SPZ250TB
280	284	4	2012	14	50	16	252	8,0	32	8,0	100	5,5	PHP 1SPZ280TB
315	319	4	2012	14	50	16	287	8,0	32	8,0	100	6,7	PHP 1SPZ315TB
355	359	4	2012	14	50	16	326	8,0	32	8,0	112	6,8	PHP 1SPZ355TB
400	404	4	2012	14	50	16	371	8,0	32	8,0	112	6,9	PHP 1SPZ400TB
450	454	4	2517	16	60	16	421	14,5	45	14,5	120	7,2	PHP 1SPZ450TB

Type 1

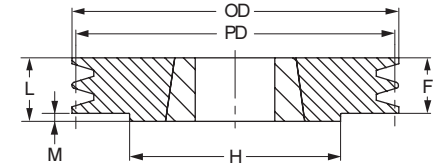

Type 4

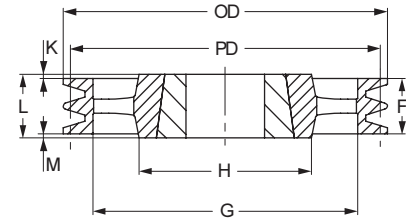

Type 6

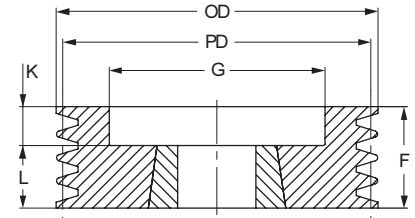

2 Groove SPZ

Pitch Diameter	OD	Pulley Type	Bush No.	Bore		F	G	K	L	M	H	Weight*	Designation
				Min	Max								
mm	mm			mm	mm	mm	mm	mm	mm	mm	mm	kg	
50	54	9	1008	9	25	49	28	27,0	22	-	-	0,4	PHP 2SPZ50TB
56	60	9	1008	9	25	49	35	27,0	22	-	-	0,5	PHP 2SPZ56TB
60	64	9	1108	9	25	49	36	27,0	22	-	-	0,7	PHP 2SPZ60TB
63	67	6	1108	9	28	28	40	6,0	22	-	-	0,3	PHP 2SPZ63TB
67	71	6	1108	9	28	28	42	6,0	22	-	-	0,4	PHP 2SPZ67TB
71	75	6	1108	9	28	28	42	6,0	22	-	-	0,5	PHP 2SPZ71TB
75	79	6	1210	11	32	28	51	3,0	25	-	-	0,5	PHP 2SPZ75TB
80	84	6	1210	11	32	28	51	3,0	25	-	-	0,6	PHP 2SPZ80TB
85	89	6	1610	14	42	28	60	3,0	25	-	-	0,6	PHP 2SPZ85TB
90	94	6	1610	14	42	28	61	3,0	25	-	-	0,7	PHP 2SPZ90TB
95	99	6	1610	14	42	28	66	3,0	25	-	-	0,8	PHP 2SPZ95TB
100	104	6	1610	14	42	28	71	3,0	25	-	-	0,9	PHP 2SPZ100TB
106	110	6	1610	14	42	28	76	3,0	25	-	-	1,1	PHP 2SPZ106TB
112	116	6	1610	14	42	28	84	3,0	25	-	-	1,3	PHP 2SPZ112TB
118	122	6	1610	14	42	28	90	3,0	25	-	-	1,5	PHP 2SPZ118TB
125	129	6	1610	14	42	28	97	3,0	25	-	-	1,7	PHP 2SPZ125TB
132	136	6	1610	14	42	28	104	3,0	25	-	-	2,0	PHP 2SPZ132TB
140	144	6	1610	14	42	28	112	3,0	25	-	-	2,4	PHP 2SPZ140TB
150	154	1	2012	14	50	28	-	-	32	4,0	100	2,6	PHP 2SPZ150TB
160	164	1	2012	14	50	28	-	-	32	4,0	100	3,1	PHP 2SPZ160TB
170	174	1	2012	14	50	28	-	-	32	4,0	100	2,8	PHP 2SPZ170TB
180	184	8	2012	14	50	28	152	-	32	4,0	100	2,9	PHP 2SPZ180TB
190	194	8	2012	14	50	28	161	-	32	4,0	100	3,1	PHP 2SPZ190TB
200	204	8	2012	14	50	28	171	-	32	4,0	100	3,4	PHP 2SPZ200TB
224	228	8	2012	14	50	28	196	-	32	4,0	100	4,5	PHP 2SPZ224TB
250	254	4	2012	14	50	28	222	2,0	32	2,0	100	5,4	PHP 2SPZ250TB
280	284	4	2012	14	50	28	252	2,0	32	2,0	100	6,2	PHP 2SPZ280TB
315	319	4	2012	14	50	28	286	2,0	32	2,0	100	7,2	PHP 2SPZ315TB
355	359	4	2012	14	50	28	326	2,0	32	2,0	112	8,6	PHP 2SPZ355TB
400	404	4	2517	16	60	28	371	8,5	45	8,5	120	9,9	PHP 2SPZ400TB
450	454	4	2517	16	60	28	421	8,5	45	8,5	120	11,2	PHP 2SPZ450TB

Type 8

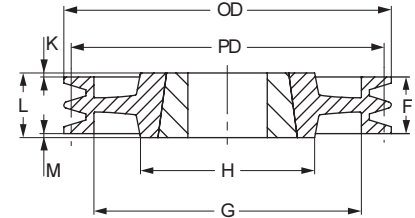

Type 9

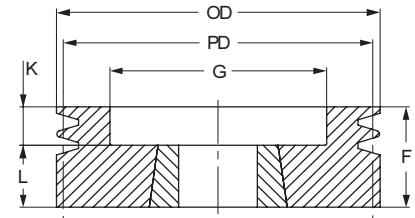

Dimensions in mm unless otherwise stated

* Weights do not include bushings

Non-functional dimensions may vary slightly



Wedge belt pulleys

SPZ taper bushed



3 Groove SPZ

Pitch Diameter	OD	Pulley Type	Bush No.	Bore		F	G	K	L	M	H	Weight*	Designation
				Min	Max								
mm	mm			mm	mm	mm	mm	mm	mm	mm	mm	kg	
63	67	6	1108	9	28	40	40	18,0	22	-	-	0,4	PHP 3SPZ63TB
67	71	6	1108	9	28	40	42	18,0	22	-	-	0,5	PHP 3SPZ67TB
71	75	6	1108	9	28	40	42	18,0	22	-	-	0,6	PHP 3SPZ71TB
75	79	6	1210	11	32	40	48	15,0	25	-	-	0,7	PHP 3SPZ75TB
80	84	6	1210	11	32	40	51	15,0	25	-	-	0,7	PHP 3SPZ80TB
85	89	6	1610	14	42	40	60	15,0	25	-	-	0,8	PHP 3SPZ85TB
90	94	6	1610	14	42	40	61	15,0	25	-	-	0,9	PHP 3SPZ90TB
95	99	6	1610	14	42	40	66	15,0	25	-	-	1,0	PHP 3SPZ95TB
100	104	6	1610	14	42	40	71	15,0	25	-	-	1,1	PHP 3SPZ100TB
106	110	6	1610	14	42	40	78	15,0	25	-	-	1,4	PHP 3SPZ106TB
112	116	6	2012	14	50	40	84	8,0	32	-	-	1,4	PHP 3SPZ112TB
118	122	6	2012	14	50	40	92	8,0	32	-	-	1,7	PHP 3SPZ118TB
125	129	2	2012	14	50	40	97	-	32	8,0	-	2,0	PHP 3SPZ125TB
132	136	2	2012	14	50	40	104	-	32	8,0	-	2,3	PHP 3SPZ132TB
140	144	2	2012	14	50	40	112	-	32	8,0	-	2,7	PHP 3SPZ140TB
150	154	2	2012	14	50	40	122	-	32	8,0	-	3,3	PHP 3SPZ150TB
160	164	2	2012	14	50	40	132	-	32	8,0	-	3,9	PHP 3SPZ160TB
170	174	2	2012	14	50	40	141	-	32	4,0	-	3,2	PHP 3SPZ170TB
180	184	2	2012	14	50	40	152	-	32	8,0	-	3,4	PHP 3SPZ180TB
190	194	7	2012	14	50	40	161	4,0	32	4,0	100	3,4	PHP 3SPZ190TB
200	204	7	2012	14	50	40	172	4,0	32	4,0	100	3,9	PHP 3SPZ200TB
224	228	7	2012	14	50	40	196	4,0	32	4,0	100	5,4	PHP 3SPZ224TB
250	254	5	2012	14	50	40	222	4,0	32	4,0	100	6,4	PHP 3SPZ250TB
280	284	4	2517	16	60	40	252	2,5	45	2,5	120	8,3	PHP 3SPZ280TB
315	319	4	2517	16	60	40	287	2,5	45	2,5	120	10,1	PHP 3SPZ315TB
355	359	4	2517	16	60	40	326	2,5	45	2,5	120	11,7	PHP 3SPZ355TB
400	404	4	2517	16	60	40	371	2,5	45	2,5	120	13,3	PHP 3SPZ400TB
450	454	4	2517	16	60	40	421	2,5	45	2,5	120	14,6	PHP 3SPZ450TB
500	504	4	2517	16	60	40	471	2,5	45	2,5	120	15,8	PHP 3SPZ500TB
630	634	4	2517	16	60	40	601	5,5	45	2,5	120	17,0	PHP 3SPZ630TB
800	804	4	3020	25	75	40	771	5,5	51	2,5	150	33,0	PHP 3SPZ800TB

Type 2

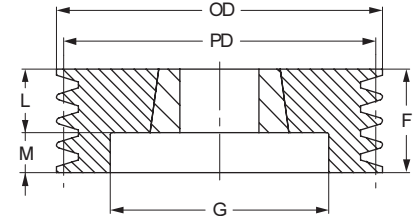

Type 4

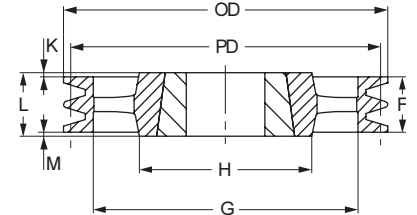

Type 5

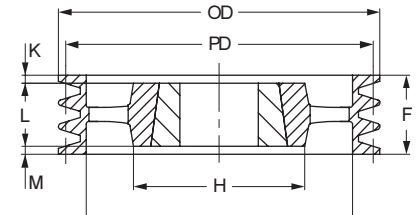

4 Groove SPZ

Pitch Diameter	OD	Pulley Type	Bush No.	Bore		F	G	K	L	M	H	Weight*	Designation
				Min	Max								
mm	mm			mm	mm	mm	mm	mm	mm	mm	mm	kg	
63	67	6	1108	9	28	52	38	30,0	22	-	-	0,5	PHP 4SPZ63TB
67	71	6	1108	9	28	52	41	30,0	22	-	-	0,6	PHP 4SPZ67TB
71	75	6	1108	9	28	52	45	30,0	22	-	-	0,7	PHP 4SPZ71TB
75	79	6	1210	11	32	52	46	27,0	25	-	-	0,8	PHP 4SPZ75TB
80	84	6	1210	11	32	52	51	27,0	25	-	-	0,9	PHP 4SPZ80TB
85	89	6	1610	14	42	52	60	27,0	25	-	-	1,0	PHP 4SPZ85TB
90	94	6	1610	14	42	52	61	27,0	25	-	-	1,1	PHP 4SPZ90TB
95	99	6	1610	14	42	52	66	27,0	25	-	-	1,3	PHP 4SPZ95TB
100	104	6	1610	14	42	52	72	27,0	25	-	-	1,4	PHP 4SPZ100TB
106	110	6	1610	14	42	52	80	27,0	25	-	-	1,6	PHP 4SPZ106TB
112	116	6	2012	14	50	52	86	20,0	32	-	-	1,7	PHP 4SPZ112TB
118	122	6	2012	14	50	52	92	20,0	32	-	-	2,0	PHP 4SPZ118TB
125	129	2	2012	14	50	52	99	-	32	20,0	-	2,3	PHP 4SPZ125TB
132	136	2	2012	14	50	52	104	-	32	20,0	-	2,6	PHP 4SPZ132TB
140	144	2	2012	14	50	52	112	-	32	20,0	-	3,1	PHP 4SPZ140TB
150	154	2	2517	16	60	52	122	-	45	7,0	-	3,8	PHP 4SPZ150TB
160	164	2	2517	16	60	52	132	-	45	7,0	-	4,6	PHP 4SPZ160TB
170	174	2	2517	16	65	52	141	-	45	7,0	-	5,5	PHP 4SPZ170TB
180	184	2	2517	16	60	52	152	-	45	7,0	-	6,3	PHP 4SPZ180TB
190	194	7	2517	16	65	52	161	3,5	45	3,5	120	5,3	PHP 4SPZ190TB
200	204	7	2517	16	60	52	172	3,5	45	3,5	120	5,4	PHP 4SPZ200TB
224	228	7	2517	16	60	52	196	3,5	45	3,5	120	7,0	PHP 4SPZ224TB
250	254	7	2517	16	60	52	222	3,5	45	3,5	120	8,0	PHP 4SPZ250TB
280	284	7	2517	16	60	52	252	3,5	45	3,5	120	9,5	PHP 4SPZ280TB
315	319	7	2517	16	60	52	287	3,5	45	3,5	120	12,1	PHP 4SPZ315TB
355	359	5	2517	16	60	52	326	3,5	45	3,5	120	12,8	PHP 4SPZ355TB
400	404	5	2517	16	60	52	371	3,5	45	3,5	120	13,6	PHP 4SPZ400TB
450	454	5	3020	25	75	52	421	0,5	51	0,5	150	14,5	PHP 4SPZ450TB
500	504	5	3020	25	75	52	471	0,5	51	0,5	150	17,3	PHP 4SPZ500TB
630	634	4	3020	25	75	52	601	12,0	76	12,0	150	23,0	PHP 4SPZ630TB
800	804	4	3030	35	75	52	771	12,0	76	12,0	150	36,0	PHP 4SPZ800TB

Type 6

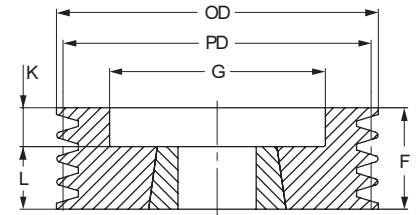

Type 7

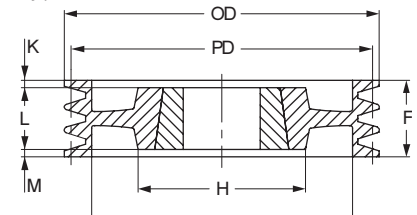

Dimensions in mm unless otherwise stated

* Weights do not include bushings

Non-functional dimensions may vary slightly



Wedge belt pulleys

SPZ taper bushed

- ▶ Belts
- ▶ Chains
- ▶ Couplings
- ▶ Bushings and Hubs
- ▶ Sprockets
- ▶ Pulleys
- ▶ Smart tools

5 Groove SPZ

Pitch Diameter	OD	Pulley Type	Bush No.	Bore		F	G	K	L	M	H	Weight*	Designation
				Min	Max								
mm	mm			mm	mm	mm	mm	mm	mm	mm	mm	kg	
85	89	6	1610	14	42	64	60	39,0	25	-	-	1,3	PHP 5SPZ85TB
90	94	6	1610	14	42	64	61	39,0	25	-	-	1,3	PHP 5SPZ90TB
95	99	6	1610	14	42	64	66	39,0	25	-	-	1,5	PHP 5SPZ95TB
100	104	6	2012	14	50	64	72	32,0	32	-	-	1,6	PHP 5SPZ100TB
106	110	6	2012	14	50	64	78	32,0	32	-	-	1,8	PHP 5SPZ106TB
112	116	6	2012	14	50	64	84	32,0	32	-	-	2,0	PHP 5SPZ112TB
118	122	6	2012	14	50	64	90	32,0	32	-	-	2,3	PHP 5SPZ118TB
125	129	6	2012	14	50	64	97	32,0	32	-	-	2,7	PHP 5SPZ125TB
132	136	6	2517	16	60	64	104	19,0	45	-	-	2,8	PHP 5SPZ132TB
140	144	2	2517	16	60	64	112	-	45	19,0	-	3,4	PHP 5SPZ140TB
150	154	2	2517	16	60	64	122	-	45	19,0	-	4,3	PHP 5SPZ150TB
160	164	2	2517	16	60	64	132	-	45	19,0	-	5,1	PHP 5SPZ160TB
170	174	2	2517	16	60	64	141	-	45	19,0	-	5,7	PHP 5SPZ170TB
180	184	2	2517	16	60	64	152	-	45	19,0	-	6,8	PHP 5SPZ180TB
190	194	7	2517	16	60	64	161	9,5	45	9,5	-	7,8	PHP 5SPZ190TB
200	204	7	2517	16	60	64	172	9,5	45	9,5	-	8,8	PHP 5SPZ200TB
224	228	7	2517	16	60	64	196	9,5	45	9,5	120	8,8	PHP 5SPZ224TB
250	254	5	2517	16	60	64	222	9,5	45	9,5	120	9,0	PHP 5SPZ250TB
280	284	5	2517	16	60	64	252	9,5	45	9,5	120	11,0	PHP 5SPZ280TB
315	319	5	2517	16	60	64	287	9,5	45	9,5	120	13,3	PHP 5SPZ315TB
355	359	5	2517	16	60	64	326	9,5	45	9,5	120	13,0	PHP 5SPZ355TB
400	404	5	3020	25	75	64	371	6,5	51	6,5	150	15,6	PHP 5SPZ400TB
450	454	5	3020	25	75	64	421	6,5	51	6,5	150	19,0	PHP 5SPZ450TB
500	504	4	3020	25	75	64	471	6,0	51	6,0	150	22,6	PHP 5SPZ500TB
630	634	4	3020	25	75	64	601	6,0	51	6,0	150	29,0	PHP 5SPZ630TB
800	804	4	3535	35	90	64	771	12,5	89	12,5	170	44,1	PHP 5SPZ800TB

Type 2

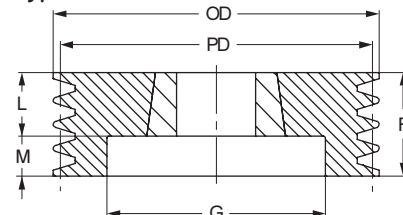

Type 4

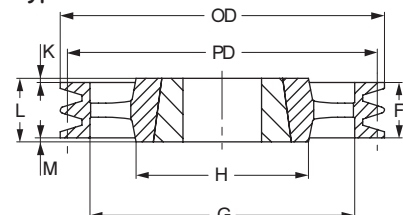

Type 5

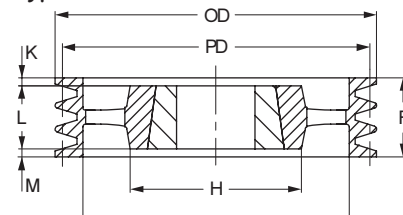

Type 6

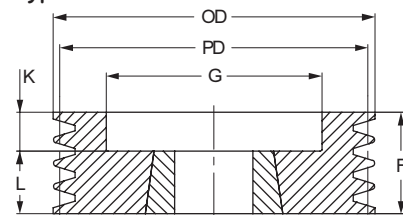

Type 7

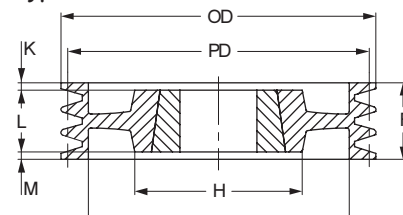

6 Groove SPZ

Pitch Diameter	OD	Pulley Type	Bush No.	Bore		F	G	K	L	M	H	Weight*	Designation
				Min	Max								
mm	mm			mm	mm	mm	mm	mm	mm	mm	mm	kg	
85	89	6	1610	14	42	76	61	51,0	25	-	-	1,3	PHP 6SPZ85TB
90	94	6	1610	14	42	76	61	51,0	25	-	-	1,5	PHP 6SPZ90TB
95	99	6	1610	14	42	76	66	51,0	25	-	-	1,7	PHP 6SPZ95TB
100	104	6	2012	14	50	76	72	44,0	32	-	-	1,9	PHP 6SPZ100TB
106	110	6	2012	14	50	76	78	44,0	32	-	-	2,0	PHP 6SPZ106TB
112	116	6	2012	14	50	76	84	44,0	32	-	-	2,3	PHP 6SPZ112TB
118	122	6	2517	16	60	76	90	31,0	45	-	-	2,3	PHP 6SPZ118TB
125	129	6	2517	16	60	76	97	31,0	45	-	-	2,7	PHP 6SPZ125TB
132	136	6	2517	16	60	76	104	31,0	45	-	-	3,2	PHP 6SPZ132TB
140	144	2	2517	16	60	76	112	-	45	31,0	-	3,8	PHP 6SPZ140TB
150	154	2	2517	16	60	76	122	-	45	31,0	-	4,6	PHP 6SPZ150TB
160	164	2	2517	16	60	76	132	-	45	31,0	-	5,5	PHP 6SPZ160TB
170	174	2	2517	16	65	76	141	-	45	31,0	-	6,5	PHP 6SPZ170TB
180	184	2	2517	16	60	76	152	-	45	31,0	-	7,3	PHP 6SPZ180TB
190	194	7	2517	16	65	76	161	15,5	45	15,5	120	8,4	PHP 6SPZ190TB
200	204	7	2517	16	60	76	172	15,5	45	15,5	120	9,4	PHP 6SPZ200TB
224	228	7	2517	16	60	76	196	15,5	45	15,5	120	9,7	PHP 6SPZ224TB
250	254	5	2517	16	60	76	222	15,5	45	15,5	120	11,8	PHP 6SPZ250TB
280	284	5	2517	16	60	76	252	15,5	45	15,5	120	12,8	PHP 6SPZ280TB
315	319	5	2517	16	60	76	287	15,5	45	15,5	120	13,8	PHP 6SPZ315TB
355	359	5	2517	16	60	76	326	15,5	45	15,5	125	15,0	PHP 6SPZ355TB
400	404	5	3030	25	75	76	371	-	76	-	150	18,3	PHP 6SPZ400TB
450	454	5	3030	25	75	76	421	-	76	-	150	21,5	PHP 6SPZ450TB
500	504	5	3030	25	75	76	471	-	76	-	150	24,6	PHP 6SPZ500TB
630	634	4	3525	35	90	76	601	6,5	89	6,5	170	35,0	PHP 6SPZ630TB
800	804	4	3535	35	90	76	771	6,5	89	6,5	170	57,9	PHP 6SPZ800TB

Dimensions in mm unless otherwise stated

* Weights do not include bushings

Non-functional dimensions may vary slightly



Wedge belt pulleys

SPZ taper bushed



8 Groove SPZ

Pitch Diameter	OD	Pulley Type	Bush No.	Bore		F	G	K	L	M	H	Weight*	Designation
				Min	Max								
140	144	3	2517	16	60	100	112	27,5	45	27,5	-	4,0	PHP 8SPZ140TB
150	154	3	2517	16	60	100	122	27,5	45	27,5	-	5,1	PHP 8SPZ150TB
160	164	3	2517	16	60	100	132	27,5	45	27,5	-	5,6	PHP 8SPZ160TB
180	184	3	3020	25	75	100	152	27,5	45	27,5	-	7,1	PHP 8SPZ180TB
200	204	3	3020	25	75	100	171	24,5	51	24,5	-	9,3	PHP 8SPZ200TB
224	228	3	3020	25	75	100	195	24,5	51	24,5	-	11,8	PHP 8SPZ224TB
250	254	7	3020	25	75	100	221	24,5	51	24,5	150	10,5	PHP 8SPZ250TB
280	284	5	3020	25	75	100	252	24,5	51	24,5	150	10,8	PHP 8SPZ280TB
355	359	5	3030	35	75	100	326	12,0	76	12,0	150	16,0	PHP 8SPZ355TB
400	404	5	3030	35	75	100	371	12,0	76	12,0	150	18,2	PHP 8SPZ400TB
450	454	5	3535	35	90	100	421	5,5	89	5,5	170	24,0	PHP 8SPZ450TB

Dimensions in mm unless otherwise stated

* Weights do not include bushings

Non-functional dimensions may vary slightly

Type 3

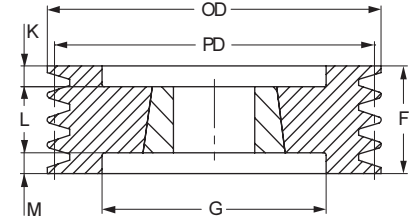

Type 5

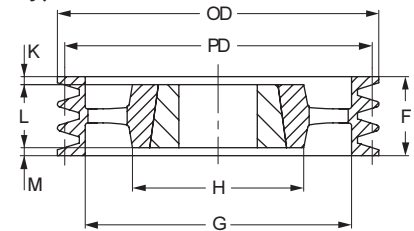

Type 7

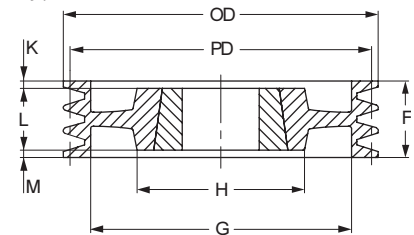



Wedge belt pulleys

SPA taper bushed

- ▶ Belts
- ▶ Chains
- ▶ Couplings
- ▶ Bushings and Hubs
- ▶ Sprockets
- ▶ Pulleys
- ▶ Smart tools

1 Groove SPA

Pitch Diameter	OD	Pulley Type	Bush No.	Bore		F	G	K	L	M	H	Weight*	Designation
				Min	Max								
mm	mm			mm	mm	mm	mm	mm	mm	mm	mm	kg	
63	68,5	9	1008	9	25	40	38	18	22	-	-	0,8	PHP 1SPA63TB
67	72,5	1	1108	9	28	20	-	-	22	2	62	0,5	PHP 1SPA67TB
71	76,5	1	1108	9	28	20	-	-	22	2	62	0,5	PHP 1SPA71TB
75	80,5	1	1108	9	28	22	-	-	22	2	62	0,4	PHP 1SPA75TB
80	85,5	1	1210	11	32	20	-	-	25	5	75	0,5	PHP 1SPA80TB
85	90,5	1	1210	11	32	20	-	-	25	5	75	0,6	PHP 1SPA85TB
90	95,5	1	1210	11	32	20	-	-	25	5	75	0,7	PHP 1SPA90TB
95	100,5	1	1210	11	32	20	-	-	25	5	75	0,9	PHP 1SPA95TB
100	105,5	1	1610	14	42	20	-	-	25	5	80	0,8	PHP 1SPA100TB
106	111,5	1	1610	14	42	20	-	-	25	5	80	0,9	PHP 1SPA106TB
112	117,5	1	1610	14	42	20	-	-	25	5	80	1,1	PHP 1SPA112TB
118	123,5	1	1610	14	42	20	-	-	25	5	80	1,2	PHP 1SPA118TB
125	130,5	1	1610	14	42	20	-	-	25	5	80	1,4	PHP 1SPA125TB
132	137,5	1	1610	14	42	20	-	-	25	5	80	1,6	PHP 1SPA132TB
140	145,5	1	1610	14	42	20	-	-	25	5	80	1,8	PHP 1SPA140TB
150	155,5	1	1610	14	42	20	-	-	25	5	80	2,1	PHP 1SPA150TB
160	165,5	1	1610	14	42	20	-	-	25	5	80	2,4	PHP 1SPA160TB
170	175,5	1	1610	14	42	20	-	-	25	5	80	1,1	PHP 1SPA170TB
180	185,5	1	1610	14	42	20	-	-	25	5	80	2,3	PHP 1SPA180TB
190	195,5	1	1610	14	42	20	-	-	25	5	80	2,7	PHP 1SPA190TB
200	205,5	8	2012	14	50	20	165	6	32	6	100	2,3	PHP 1SPA200TB
212	217,5	8	2012	14	50	20	177	6	32	6	100	3,5	PHP 1SPA212TB
224	229,5	8	2012	14	50	20	189	6	32	6	100	4,0	PHP 1SPA224TB
250	255,5	8	2012	14	50	20	215	6	32	6	100	4,8	PHP 1SPA250TB
280	285,5	8	2012	14	50	20	245	6	32	6	100	6,3	PHP 1SPA280TB
315	320,5	8	2012	14	50	20	280	6	32	6	100	7,2	PHP 1SPA315TB
355	360,5	4	2012	14	50	20	320	6	32	6	100	7,6	PHP 1SPA355TB
400	405,5	4	2012	14	50	20	365	6	32	6	100	7,9	PHP 1SPA400TB
450	455,5	4	2012	16	60	20	415	6	32	6	100	8,4	PHP 1SPA450TB
500	505,5	4	2517	16	60	20	465	-	45	25	120	9,4	PHP 1SPA500TB
630	635,5	4	2517	16	60	20	595	-	45	25	120	13,1	PHP 1SPA630TB

Type 1

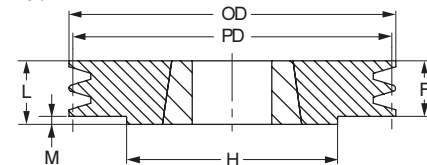

Type 4

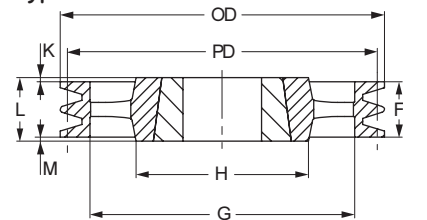

Type 6

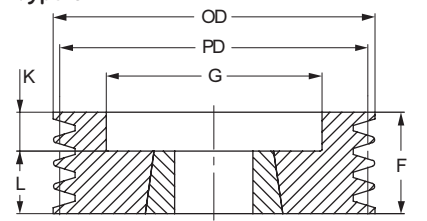

2 Groove SPA

Pitch Diameter	OD	Pulley Type	Bush No.	Bore		F	G	K	L	M	H	Weight*	Designation
				Min	Max								
mm	mm			mm	mm	mm	mm	mm	mm	mm	mm	kg	
63	68,5	9	1008	9	28	55	36	33	22	-	-	0,6	PHP 2SPA63TB
67	72,5	6	1108	9	28	35	37	13	22	-	-	0,4	PHP 2SPA67TB
71	76,5	6	1108	9	28	35	40	13	22	-	-	0,5	PHP 2SPA71TB
75	80,5	6	1108	9	28	35	44	10	25	-	-	0,7	PHP 2SPA75TB
80	85,5	6	1210	11	32	35	47	10	25	-	-	0,6	PHP 2SPA80TB
85	90,5	6	1210	11	32	35	50	10	25	-	-	0,7	PHP 2SPA85TB
90	95,5	6	1610	14	42	35	60	10	25	-	-	0,7	PHP 2SPA90TB
95	100,5	6	1610	14	42	35	64	10	25	-	-	0,9	PHP 2SPA95TB
100	105,5	6	1610	14	42	35	70	10	25	-	-	1,1	PHP 2SPA100TB
106	111,5	6	1610	14	42	35	76	10	25	-	-	1,2	PHP 2SPA106TB
112	117,5	6	1610	14	42	35	80	10	25	-	-	1,4	PHP 2SPA112TB
118	123,5	6	1610	14	42	35	86	10	25	-	-	1,6	PHP 2SPA118TB
125	130,5	6	1610	14	42	35	90	10	25	-	-	1,9	PHP 2SPA125TB
132	137,5	6	2012	14	50	35	98	3	32	-	-	2,1	PHP 2SPA132TB
140	145,5	6	2012	14	50	35	106	3	32	-	-	2,6	PHP 2SPA140TB
150	155,5	6	2012	14	50	35	116	3	32	-	-	3,2	PHP 2SPA150TB
160	165,5	6	2012	14	50	35	125	3	32	-	-	3,8	PHP 2SPA160TB
170	175,5	6	2012	14	50	35	135	3	32	-	-	4,5	PHP 2SPA170TB
180	185,5	7	2012	14	50	35	148	1,5	32	1,5	100	5,2	PHP 2SPA180TB
190	195,5	7	2012	14	50	35	158	1,5	32	1,5	100	4,4	PHP 2SPA190TB
200	205,5	8	2517	16	60	35	165	5	45	5	120	4,9	PHP 2SPA200TB
212	217,5	8	2517	16	60	35	177	5	45	5	120	5,8	PHP 2SPA212TB
224	229,5	8	2517	16	60	35	189	-	45	10	120	6,6	PHP 2SPA224TB
250	255,5	8	2517	16	60	35	215	5	45	5	120	6,8	PHP 2SPA250TB
280	285,5	8	2517	16	60	35	245	-	45	10	120	8,3	PHP 2SPA280TB
315	320,5	8	2517	16	60	35	280	-	45	10	120	10,2	PHP 2SPA315TB
355	360,5	4	2517	16	60	35	320	-	45	10	120	10,5	PHP 2SPA355TB
400	405,5	4	2517	16	60	35	365	-	45	10	120	11,3	PHP 2SPA400TB
450	455,5	4	2517	16	60	35	465	-	45	10	120	15,0	PHP 2SPA450TB
500	505,5	4	2517	16	60	35	525	-	51	16	150	18,7	PHP 2SPA500TB
630	635,5	4	3020	25	75	35	595	-	51	16	150	22,0	PHP 2SPA630TB

Type 7

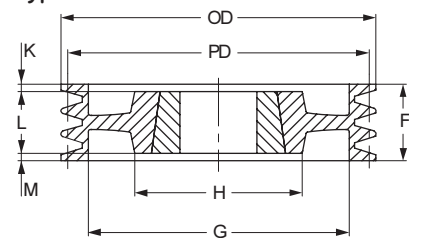

Type 8

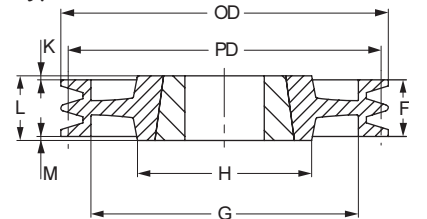

Type 9

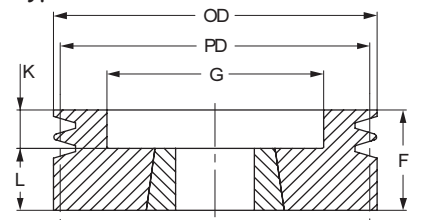

Dimensions in mm unless otherwise stated

* Weights do not include bushings

Non-functional dimensions may vary slightly



Wedge belt pulleys

SPA taper bushed



3 Groove SPA

Pitch Diameter	OD	Pulley Type	Bush No.	Bore		F	G	K	L	M	H	Weight*	Designation
				Min	Max								
mm	mm			mm	mm	mm	mm	mm	mm	mm	mm	kg	
71	76,5	6	1108	9	28	50	40	28,0	22	-	-	0,7	PHP 3SPA71TB
75	80,5	6	1210	11	32	50	44	25,0	25	-	-	0,8	PHP 3SPA75TB
80	85,5	6	1210	11	32	50	47	25,0	25	-	-	0,9	PHP 3SPA80TB
85	90,5	6	1210	11	32	50	50	25,0	25	-	-	1,0	PHP 3SPA85TB
90	95,5	6	1610	14	42	50	60	25,0	25	-	-	1,0	PHP 3SPA90TB
95	100,5	6	1610	14	42	50	64	25,0	25	-	-	1,2	PHP 3SPA95TB
100	105,5	2	1610	14	42	50	70	-	25	25,0	-	1,3	PHP 3SPA100TB
106	111,5	2	1610	14	42	50	76	-	25	25,0	-	1,6	PHP 3SPA106TB
112	117,5	6	2012	14	50	50	83	18,0	32	-	-	1,6	PHP 3SPA112TB
118	123,5	2	2012	14	50	50	86	-	32	18,0	-	1,9	PHP 3SPA118TB
125	130,5	2	2012	14	50	50	92	-	32	18,0	-	2,3	PHP 3SPA125TB
132	137,5	2	2012	14	50	50	98	-	32	18,0	-	2,6	PHP 3SPA132TB
140	145,5	6	2517	16	60	50	106	5,0	45	-	-	2,9	PHP 3SPA140TB
150	155,5	6	2517	16	60	50	116	5,0	45	-	-	3,7	PHP 3SPA150TB
160	165,5	6	2517	16	60	50	126	5,0	45	-	-	4,5	PHP 3SPA160TB
170	175,5	6	2517	16	60	50	138	5,0	45	-	-	5,0	PHP 3SPA170TB
180	185,5	6	2517	16	60	50	146	5,0	45	-	-	6,2	PHP 3SPA180TB
190	195,5	6	2517	16	60	50	158	5,0	45	-	-	7,0	PHP 3SPA190TB
200	205,5	7	2517	16	60	50	165	2,5	45	2,5	120	5,6	PHP 3SPA200TB
212	217,5	7	2517	16	60	50	177	2,5	45	2,5	120	6,6	PHP 3SPA212TB
224	229,5	7	2517	16	60	50	189	2,5	45	2,5	120	7,5	PHP 3SPA224TB
250	255,5	7	2517	16	60	50	215	2,5	45	2,5	120	8,6	PHP 3SPA250TB
280	285,5	7	2517	16	60	50	245	2,5	45	2,5	120	10,0	PHP 3SPA280TB
315	320,5	8	3020	25	75	50	280	0,5	51	0,5	160	12,8	PHP 3SPA315TB
355	360,5	4	3020	25	75	50	320	0,5	51	0,5	150	13,4	PHP 3SPA355TB
400	405,5	4	3020	25	75	50	365	0,5	51	0,5	150	15,9	PHP 3SPA400TB
450	455,5	4	3020	25	75	50	415	0,5	51	0,5	150	19,3	PHP 3SPA450TB
500	505,5	4	3020	25	75	50	465	0,5	51	0,5	150	22,6	PHP 3SPA500TB
560	565,5	4	3020	25	75	50	525	0,5	51	0,5	150	23,5	PHP 3SPA560TB
630	635,5	4	3020	25	75	50	595	0,5	51	0,5	150	27,5	PHP 3SPA630TB
800	805,5	4	3535	35	90	50	765	19,5	89	19,5	170	40,8	PHP 3SPA800TB
1000	1005,5	4	3535	35	90	50	965	19,5	89	19,5	178	50,0	PHP 3SPA1000TB

4 Groove SPA

Pitch Diameter	OD	Pulley Type	Bush No.	Bore		F	G	K	L	M	H	Weight*	Designation
				Min	Max								
mm	mm			mm	mm	mm	mm	mm	mm	mm	mm	kg	
90	95,5	3	1615	14	42	65	64	13,5	38	13,5	-	1,2	PHP 4SPA90TB
95	100,5	3	1615	14	42	65	64	13,5	38	13,5	-	1,4	PHP 4SPA95TB
100	105,5	2	1615	14	42	65	70	-	38	27,0	-	1,6	PHP 4SPA100TB
106	111,5	6	2012	14	50	65	76	33,0	32	-	-	1,7	PHP 4SPA106TB
112	117,5	6	2012	14	50	65	80	33,0	32	-	-	2,0	PHP 4SPA112TB
118	123,5	2	2012	14	50	65	86	-	32	33,0	-	2,3	PHP 4SPA118TB
125	130,5	2	2012	14	50	65	92	-	32	33,0	-	2,7	PHP 4SPA125TB
132	137,5	2	2517	16	60	65	98	-	45	20,0	-	2,9	PHP 4SPA132TB
140	145,5	2	2517	16	60	65	106	-	45	20,0	-	3,5	PHP 4SPA140TB
150	155,5	2	2517	16	60	65	116	-	45	20,0	-	4,2	PHP 4SPA150TB
160	165,5	2	2517	16	60	65	126	-	45	20,0	-	5,1	PHP 4SPA160TB
170	175,5	2	2517	16	60	65	138	-	45	20,0	-	6,0	PHP 4SPA170TB
180	185,5	2	2517	16	60	65	146	-	45	20,0	-	6,9	PHP 4SPA180TB
190	195,5	2	2517	16	60	65	158	-	45	20,0	-	7,2	PHP 4SPA190TB
200	205,5	2	3020	25	75	65	165	-	51	14,0	-	8,4	PHP 4SPA200TB
212	217,5	2	3020	25	75	65	177	-	51	14,0	-	9,9	PHP 4SPA212TB
224	229,5	2	3020	25	75	65	189	-	51	14,0	-	11,4	PHP 4SPA224TB
250	255,5	7	3020	25	75	65	215	7,0	51	7,0	150	10,5	PHP 4SPA250TB
280	285,5	7	3020	25	75	65	245	7,0	51	7,0	150	11,6	PHP 4SPA280TB
315	320,5	7	3020	25	75	65	280	7,0	51	7,0	150	13,8	PHP 4SPA315TB
355	360,5	5	3020	25	75	65	320	7,0	51	7,0	150	15,8	PHP 4SPA355TB
400	405,5	5	3020	25	75	65	365	7,0	51	7,0	150	17,7	PHP 4SPA400TB
450	455,5	5	3020	25	75	65	415	7,0	51	7,0	150	23,2	PHP 4SPA450TB
500	505,5	5	3020	25	75	65	465	7,0	51	7,0	150	27,4	PHP 4SPA500TB
560	565,5	4	3535	35	90	65	525	12,0	89	12,0	170	30,5	PHP 4SPA560TB
630	635,5	4	3535	35	90	65	595	12,0	89	12,0	170	34,1	PHP 4SPA630TB
800	805,5	4	3535	35	90	65	765	12,0	89	12,0	170	50,8	PHP 4SPA800TB
1000	1005,5	4	4040	40	100	65	965	18,5	102	18,5	216	62,0	PHP 4SPA1000TB

Dimensions in mm unless otherwise stated

* Weights do not include bushings

Non-functional dimensions may vary slightly

Type 2

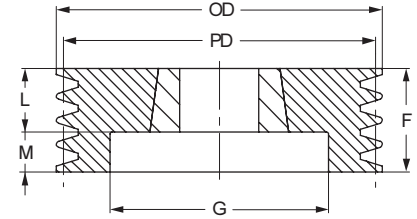

Type 3

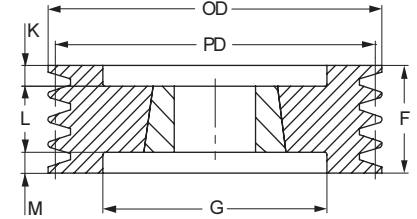

Type 4

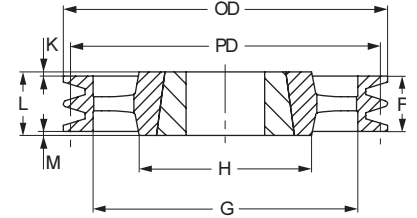

Type 5

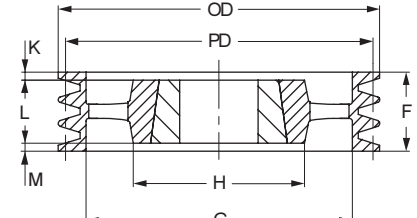

Type 6

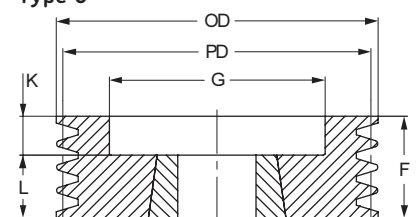

Type 7

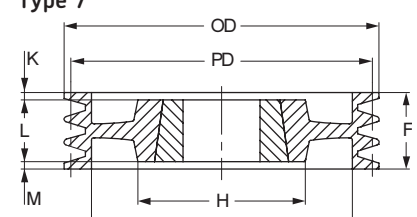

Type 8

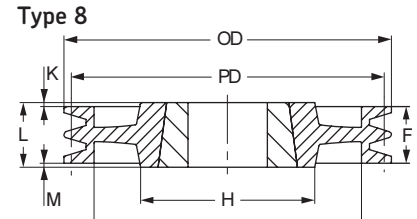



Wedge belt pulleys

SPA taper bushed

- ▶ Belts
- ▶ Chains
- ▶ Couplings
- ▶ Bushings and Hubs
- ▶ Sprockets
- ▶ Pulleys
- ▶ Smart tools

5 Groove SPA

Pitch Diameter	OD	Pulley Type	Bush No.	Bore		F	G	K	L	M	H	Weight*	Designation
				Min	Max								
mm	mm			mm	mm	mm	mm	mm	mm	mm	mm	kg	
100	105,5	2	1615	14	42	80	70	-	38	42,0	-	1,9	PHP 5SPA100TB
106	111,5	6	2012	14	50	80	76	48,0	32	-	-	2,1	PHP 5SPA106TB
112	117,5	6	2012	14	50	80	80	48,0	32	-	-	2,4	PHP 5SPA112TB
118	123,5	2	2012	14	50	80	86	-	32	48,0	-	2,7	PHP 5SPA118TB
125	130,5	3	2012	14	50	80	92	24,0	32	24,0	-	3,1	PHP 5SPA125TB
132	137,5	3	2517	16	60	80	98	17,5	45	17,5	-	3,2	PHP 5SPA132TB
140	145,5	3	2517	16	60	80	106	17,5	45	17,5	-	3,9	PHP 5SPA140TB
150	155,5	3	2517	16	60	80	116	17,5	45	17,5	-	4,7	PHP 5SPA150TB
160	165,5	3	2517	16	60	80	126	17,5	45	17,5	-	5,6	PHP 5SPA160TB
170	175,5	3	2517	16	60	80	146	17,5	45	17,5	-	6,2	PHP 5SPA170TB
180	185,5	3	3020	25	75	80	165	14,5	51	14,5	-	6,8	PHP 5SPA180TB
190	195,5	2	3020	25	75	80	189	-	51	29,0	-	7,4	PHP 5SPA190TB
200	205,5	3	3020	25	75	80	215	14,5	51	14,5	-	9,1	PHP 5SPA200TB
212	217,5	2	3020	25	75	80	245	-	51	29,0	-	10,7	PHP 5SPA212TB
224	229,5	2	3020	25	75	80	280	-	51	29,0	-	12,3	PHP 5SPA224TB
250	255,5	7	3020	25	75	80	215	14,5	51	14,5	150	11,7	PHP 5SPA250TB
280	285,5	8	3535	35	90	80	245	4,5	89	4,5	170	17,4	PHP 5SPA280TB
315	320,5	8	3535	35	90	80	280	4,5	89	4,5	170	20,0	PHP 5SPA315TB
355	360,5	4	3535	35	90	80	320	4,5	89	4,5	170	22,8	PHP 5SPA355TB
400	405,5	4	3535	35	90	80	365	4,5	89	4,5	170	24,8	PHP 5SPA400TB
450	455,5	4	3535	35	90	80	415	4,5	89	4,5	170	28,5	PHP 5SPA450TB
500	505,5	4	3535	35	90	80	465	4,5	89	4,5	170	31,7	PHP 5SPA500TB
560	565,5	4	3535	35	90	80	525	4,5	89	4,5	170	35,0	PHP 5SPA560TB
630	635,5	4	3535	35	90	80	595	4,5	89	4,5	170	42,0	PHP 5SPA630TB
800	805,5	4	4030	40	100	80	765	11,0	102	11,0	216	60,0	PHP 5SPA800TB
1000	1005,5	4	4545	55	120	80	965	17,0	114	17,0	225	70,0	PHP 5SPA1000TB

6 Groove SPA

Pitch Diameter	OD	Pulley Type	Bush No.	Bore		F	G	K	L	M	H	Weight*	Designation
				Min	Max								
mm	mm			mm	mm	mm	mm	mm	mm	mm	mm	kg	
100	105,5	3	1610	14	42	95	70	28,5	38	28,5	-	2,2	PHP 6SPA100TB
106	111,5	6	2012	14	50	95	76	63,0	32	-	-	2,5	PHP 6SPA106TB
112	117,5	6	2012	14	50	95	80	63,0	32	-	-	2,8	PHP 6SPA112TB
118	123,5	6	2012	14	50	95	86	63,0	32	-	-	3,1	PHP 6SPA118TB
125	130,5	3	2012	14	50	95	92	31,5	32	31,5	-	3,7	PHP 6SPA125TB
132	137,5	3	2517	16	60	95	98	25,0	45	25,0	-	3,6	PHP 6SPA132TB
140	145,5	3	2517	16	60	95	106	25,0	45	25,0	-	4,5	PHP 6SPA140TB
150	155,5	3	2517	16	60	95	116	25,0	45	25,0	-	5,3	PHP 6SPA150TB
160	165,5	3	2517	16	60	95	126	25,0	45	25,0	-	6,3	PHP 6SPA160TB
170	175,5	3	3020	25	75	95	135	22,0	51	22,0	-	6,3	PHP 6SPA170TB
180	185,5	3	3020	25	75	95	146	22,0	51	22,0	-	7,5	PHP 6SPA180TB
190	195,5	3	3020	25	75	95	155	22,0	51	22,0	-	8,6	PHP 6SPA190TB
200	205,5	3	3020	25	75	95	165	22,0	51	22,0	-	9,9	PHP 6SPA200TB
212	217,5	3	3020	25	75	95	176	22,0	51	22,0	-	11,6	PHP 6SPA212TB
224	229,5	3	3020	25	75	95	189	22,0	51	22,0	-	13,2	PHP 6SPA224TB
250	255,5	7	3020	25	75	95	215	22,0	51	22,0	150	12,5	PHP 6SPA250TB
280	285,5	7	3535	35	90	95	245	3,0	89	3,0	170	19,0	PHP 6SPA280TB
315	320,5	7	3535	35	90	95	280	3,0	89	3,0	170	21,1	PHP 6SPA315TB
355	360,5	5	3535	35	90	95	320	3,0	89	3,0	170	23,5	PHP 6SPA355TB
400	405,5	5	3535	35	90	95	365	3,0	89	3,0	170	26,0	PHP 6SPA400TB
450	455,5	5	3535	35	90	95	415	3,0	89	3,0	170	30,0	PHP 6SPA450TB
500	505,5	5	3535	35	90	95	465	3,0	89	3,0	170	34,0	PHP 6SPA500TB
560	565,5	5	3535	35	90	95	525	3,0	89	3,0	170	39,0	PHP 6SPA560TB
630	635,5	4	4030	40	100	95	595	3,5	102	3,5	216	53,5	PHP 6SPA630TB
800	805,5	4	4030	40	100	95	765	3,5	102	3,5	216	70,0	PHP 6SPA800TB
1000	1005,5	4	4545	55	120	95	965	9,5	114	9,5	225	85,5	PHP 6SPA1000TB

Dimensions in mm unless otherwise stated
 * Weights do not include bushings
 Non-functional dimensions may vary slightly

Type 2

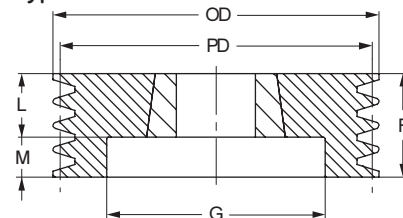

Type 3

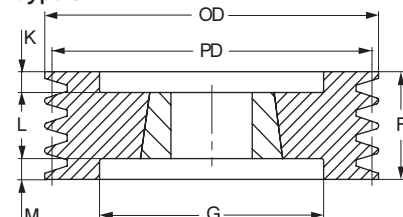

Type 4

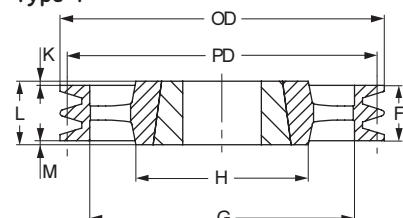

Type 5

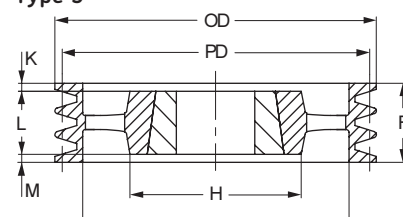

Type 6

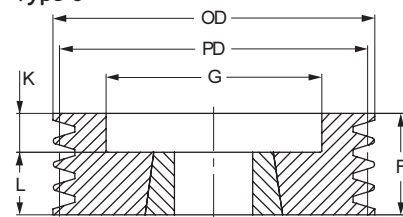

Type 7

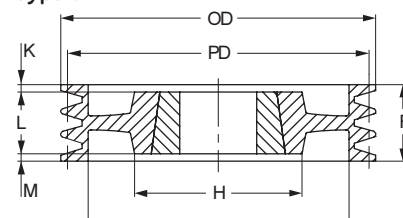

Type 8

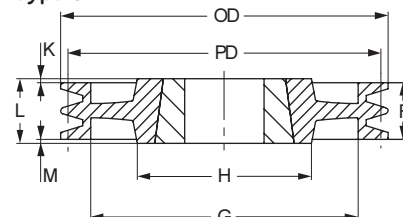



Wedge belt pulleys

SPB taper bushed



1 Groove SPB

Pitch Diameter	OD	Pulley Type	Bush No.	Bore		F	G	K	L	M	H	Weight*	Designation
				Min	Max								
mm	mm			mm	mm	mm	mm	mm	mm	mm	mm	kg	
100	107	1	1610	14	42	25	-	-	25	-	-	0,8	PHP 1SPB100TB
106	113	1	1610	14	42	25	-	-	25	-	-	1,0	PHP 1SPB106TB
112	119	1	1610	14	42	25	-	-	25	-	-	1,2	PHP 1SPB112TB
118	125	1	1610	14	42	25	-	-	25	-	-	1,5	PHP 1SPB118TB
125	132	1	1610	14	42	25	-	-	25	-	-	1,5	PHP 1SPB125TB
132	139	1	1610	14	42	25	-	-	25	-	-	1,8	PHP 1SPB132TB
140	147	1	1610	14	42	25	-	-	25	-	-	2,1	PHP 1SPB140TB
150	157	1	1610	14	42	25	-	-	25	-	-	2,5	PHP 1SPB150TB
160	167	1	1610	14	42	25	-	-	25	-	-	2,9	PHP 1SPB160TB
170	177	1	1610	14	42	25	-	-	25	-	-	3,0	PHP 1SPB170TB
180	187	7	1610	14	42	25	137	-	25	-	80	3,8	PHP 1SPB180TB
190	197	8	2012	14	50	25	147	3,5	32	3,5	100	4,4	PHP 1SPB190TB
200	207	8	2012	14	50	25	157	3,5	32	3,5	100	4,0	PHP 1SPB200TB
212	219	8	2012	14	50	25	169	3,5	32	3,5	100	5,2	PHP 1SPB212TB
224	231	8	2012	14	50	25	181	3,5	32	3,5	100	5,2	PHP 1SPB224TB
236	243	8	2012	14	50	25	193	3,5	32	3,5	100	5,4	PHP 1SPB236TB
250	257	8	2012	14	50	25	207	3,5	32	3,5	100	6,2	PHP 1SPB250TB
280	287	8	2012	14	50	25	237	3,5	32	3,5	100	6,5	PHP 1SPB280TB
300	307	8	2012	14	50	25	258	3,5	32	3,5	100	7,0	PHP 1SPB300TB
315	322	8	2012	14	50	25	272	3,5	32	3,5	100	7,5	PHP 1SPB315TB
335	342	8	2517	16	60	25	288	10,0	45	10,0	125	8,5	PHP 1SPB335TB
355	362	8	3020	25	75	25	312	13,0	51	13,0	146	9,5	PHP 1SPB355TB
400	407	8	3020	25	75	25	357	13,0	51	13,0	146	11,0	PHP 1SPB400TB
450	457	4	3020	25	75	25	407	13,0	51	13,0	146	12,3	PHP 1SPB450TB
500	507	4	3020	25	75	25	457	13,0	51	13,0	146	14,6	PHP 1SPB500TB
560	567	4	3020	25	75	25	517	13,0	51	13,0	146	18,5	PHP 1SPB560TB
630	637	4	3020	25	75	25	587	13,0	51	13,0	146	20,5	PHP 1SPB630TB

Type 1

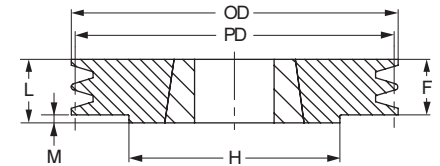

Type 2

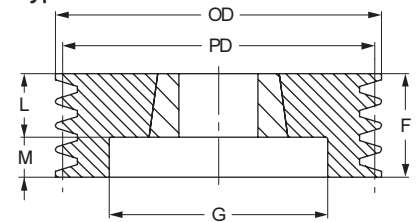

Type 4

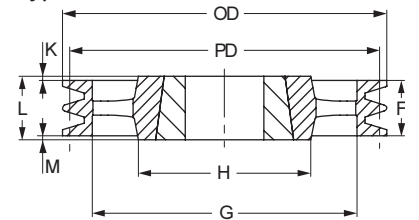

2 Groove SPB

Pitch Diameter	OD	Pulley Type	Bush No.	Bore		F	G	K	L	M	H	Weight*	Designation
				Min	Max								
mm	mm			mm	mm	mm	mm	mm	mm	mm	mm	kg	
100	107	2	1610	14	42	44	62	-	25	19,0	-	1,3	PHP 2SPB100TB
106	113	2	1610	14	42	44	67	-	25	19,0	-	1,5	PHP 2SPB106TB
112	119	2	1610	14	42	44	72	-	25	19,0	-	1,5	PHP 2SPB112TB
118	125	2	1610	14	42	44	78	-	25	19,0	-	1,7	PHP 2SPB118TB
125	132	2	2012	14	50	44	82	-	32	12,0	-	2,0	PHP 2SPB125TB
132	139	2	2012	14	50	44	89	-	32	12,0	-	2,4	PHP 2SPB132TB
140	147	2	2012	14	50	44	97	-	32	12,0	-	2,8	PHP 2SPB140TB
150	157	2	2012	14	50	44	107	-	32	12,0	-	3,3	PHP 2SPB150TB
160	167	2	2012	14	50	44	117	-	32	12,0	-	4,0	PHP 2SPB160TB
170	177	2	2012	14	50	44	127	-	32	12,0	-	4,4	PHP 2SPB170TB
180	187	1	2517	16	60	44	-	-	45	1,0	120	5,5	PHP 2SPB180TB
190	197	1	2517	16	60	44	-	-	45	1,0	120	6,5	PHP 2SPB190TB
200	207	1	2517	16	60	44	-	-	45	1,0	120	7,5	PHP 2SPB200TB
212	219	8	2517	16	60	44	169	-	45	1,0	120	7,0	PHP 2SPB212TB
224	231	8	2517	16	60	44	181	-	45	1,0	120	7,7	PHP 2SPB224TB
236	243	8	2517	16	60	44	193	-	45	1,0	120	8,3	PHP 2SPB236TB
250	257	8	2517	16	60	44	207	-	45	1,0	120	8,6	PHP 2SPB250TB
280	287	8	2517	16	60	44	237	-	45	1,0	120	10,1	PHP 2SPB280TB
300	307	8	2517	16	60	44	257	-	45	1,0	120	11,0	PHP 2SPB300TB
315	322	8	2517	16	60	44	272	-	45	1,0	120	12,2	PHP 2SPB315TB
335	342	8	2517	16	60	44	292	-	45	1,0	120	14,0	PHP 2SPB335TB
355	362	4	3020	25	75	44	312	3,5	51	3,5	120	15,9	PHP 2SPB355TB
400	407	4	3020	25	75	44	357	3,5	51	3,5	150	18,3	PHP 2SPB400TB
450	457	4	3020	25	75	44	407	3,5	51	3,5	150	16,3	PHP 2SPB450TB
500	507	4	3020	25	75	44	457	3,5	51	3,5	150	18,6	PHP 2SPB500TB
560	567	4	3020	25	75	44	517	4,0	76	28,0	150	22,5	PHP 2SPB560TB
630	637	4	3020	25	75	44	587	4,0	76	16,0	150	25,5	PHP 2SPB630TB

Type 7

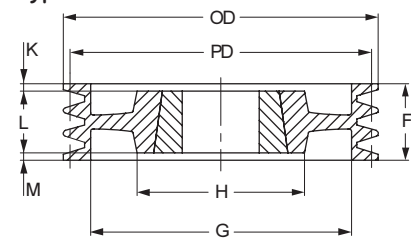

Type 8

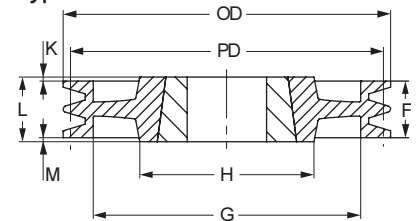

Dimensions in mm unless otherwise stated

* Weights do not include bushings

Non-functional dimensions may vary slightly



Wedge belt pulleys

SPB taper bushed

- ▶ Belts
- ▶ Chains
- ▶ Couplings
- ▶ Bushings and Hubs
- ▶ Sprockets
- ▶ Pulleys
- ▶ Smart tools

3 Groove SPB

Pitch Diameter	OD	Pulley Type	Bush No.	Bore		F	G	K	L	M	H	Weight*	Designation
				Min	Max								
mm	mm			mm	mm	mm	mm	mm	mm	mm	mm	kg	
100	107	6	1610	14	42	63	57	-	25	38	-	0,9	PHP 3SPB100TB
106	113	6	1610	14	42	63	67	-	25	38	-	2,0	PHP 3SPB106TB
112	119	6	1610	14	42	63	72	-	25	38	-	2,0	PHP 3SPB112TB
118	125	2	1610	14	42	63	78	-	25	38	-	2,3	PHP 3SPB118TB
125	132	2	2012	14	50	63	82	-	32	31	-	2,5	PHP 3SPB125TB
132	139	2	2012	14	50	63	89	-	32	31	-	3,1	PHP 3SPB132TB
140	147	2	2012	14	50	63	97	-	32	31	-	3,5	PHP 3SPB140TB
150	157	2	2517	16	60	63	107	-	45	18	-	4,0	PHP 3SPB150TB
160	167	2	2517	16	60	63	117	-	45	18	-	4,9	PHP 3SPB160TB
170	177	2	2517	16	60	63	127	-	45	18	-	5,7	PHP 3SPB170TB
180	187	2	2517	16	60	63	137	-	45	18	-	6,7	PHP 3SPB180TB
190	197	2	2517	16	60	63	147	-	45	18	-	7,6	PHP 3SPB190TB
200	207	2	2517	16	60	63	157	-	45	18	-	8,9	PHP 3SPB200TB
212	219	7	2517	16	60	63	169	-	45	18	120	8,2	PHP 3SPB212TB
224	231	7	2517	16	60	63	181	-	45	18	120	9,1	PHP 3SPB224TB
236	243	7	2517	16	60	63	193	-	45	18	120	9,8	PHP 3SPB236TB
250	257	7	3020	25	75	63	207	-	51	12	150	11,2	PHP 3SPB250TB
280	287	7	3020	25	75	63	237	6	51	6	150	12,0	PHP 3SPB280TB
300	307	7	3020	25	75	63	257	6	51	6	150	13,5	PHP 3SPB300TB
315	322	7	3020	25	75	63	272	6	51	6	150	14,2	PHP 3SPB315TB
335	342	7	3020	25	75	63	292	6	51	6	150	16,0	PHP 3SPB335TB
355	362	5	3020	25	75	63	312	6	51	6	150	17,7	PHP 3SPB355TB
400	407	4	3535	35	90	63	357	13	89	13	170	25,0	PHP 3SPB400TB
450	457	4	3535	35	90	63	407	-	89	26	170	26,3	PHP 3SPB450TB
500	507	4	3535	35	90	63	457	-	89	26	170	29,9	PHP 3SPB500TB
560	567	4	3535	35	90	63	517	-	89	26	170	37,2	PHP 3SPB560TB
630	637	4	3535	35	90	63	587	-	89	26	170	41,0	PHP 3SPB630TB
710	717	4	3535	35	90	63	664	4	89	22	170	48,0	PHP 3SPB710TB
800	807	4	3535	35	90	63	754	4	89	22	170	55,0	PHP 3SPB800TB
900	907	4	3535	35	90	63	854	4	89	22	170	64,1	PHP 3SPB900TB
1000	1007	4	4040	40	100	63	954	6	102	33	200	72,0	PHP 3SPB1000TB
1250	1257	4	4040	40	100	63	1204	6	102	33	200	140,0	PHP 3SPB1250TB

4 Groove SPB

Pitch Diameter	OD	Pulley Type	Bush No.	Bore		F	G	K	L	M	H	Weight*	Designation
				Min	Max								
mm	mm			mm	mm	mm	mm	mm	mm	mm	mm	kg	
100	107	3	1210	11	32	82	58	29,0	25	29,0	-	2,4	PHP 4SPB100TB
106	113	3	1610	14	42	82	65	29,0	25	29,0	-	2,3	PHP 4SPB106TB
112	119	3	1610	14	42	82	65	29,0	25	29,0	-	2,8	PHP 4SPB112TB
118	125	3	1610	14	42	82	71	29,0	25	29,0	-	3,3	PHP 4SPB118TB
125	132	3	2012	14	50	82	82	25,0	32	25,0	-	3,0	PHP 4SPB125TB
132	139	3	2012	14	50	82	89	25,0	32	25,0	-	3,8	PHP 4SPB132TB
140	147	3	2517	16	60	82	97	18,5	45	18,5	-	4,0	PHP 4SPB140TB
150	157	3	2517	16	60	82	107	18,5	45	18,5	-	4,9	PHP 4SPB150TB
160	167	3	2517	16	60	82	117	18,5	45	18,5	-	5,8	PHP 4SPB160TB
170	177	3	2517	16	60	82	127	18,5	45	18,5	-	6,6	PHP 4SPB170TB
180	187	3	2517	16	60	82	137	18,5	45	18,5	-	7,7	PHP 4SPB180TB
190	197	3	2517	16	60	82	147	18,5	45	18,5	-	8,6	PHP 4SPB190TB
200	207	3	3020	25	75	82	157	15,5	51	15,5	-	9,3	PHP 4SPB200TB
212	219	3	3020	25	75	82	169	15,5	51	15,5	-	10,9	PHP 4SPB212TB
224	231	3	3020	25	75	82	181	15,5	51	15,5	-	12,4	PHP 4SPB224TB
236	243	3	3020	25	75	82	193	15,5	51	15,5	-	14,1	PHP 4SPB236TB
250	257	7	3020	25	75	82	207	15,5	51	15,5	150	12,7	PHP 4SPB250TB
280	287	7	3020	25	75	82	237	15,5	51	15,5	150	13,8	PHP 4SPB280TB
300	307	7	3535	35	90	82	257	15,5	89	7,0	150	20,5	PHP 4SPB300TB
315	322	8	3535	35	90	82	272	3,5	89	3,5	170	20,6	PHP 4SPB315TB
335	342	8	3535	35	90	82	292	3,5	89	3,5	170	22,0	PHP 4SPB335TB
355	362	8	3535	35	90	82	312	3,5	89	3,5	170	23,2	PHP 4SPB355TB
400	407	4	3535	35	90	82	357	3,5	89	3,5	170	26,5	PHP 4SPB400TB
450	457	4	3535	35	90	82	407	-	89	7,0	170	29,7	PHP 4SPB450TB
500	507	4	3535	35	90	82	457	-	89	7,0	170	34,7	PHP 4SPB500TB
560	567	4	3535	35	90	82	517	-	89	7,0	170	39,0	PHP 4SPB560TB
630	637	4	3535	35	90	82	587	-	89	7,0	170	44,5	PHP 4SPB630TB
710	717	4	3535	35	90	82	664	3,5	89	3,5	187	50,5	PHP 4SPB710TB
800	807	4	4040	40	100	82	754	10,0	102	10,0	200	60,5	PHP 4SPB800TB
900	907	4	4040	40	100	82	854	10,0	102	10,0	216	70,0	PHP 4SPB900TB
1000	1007	4	4040	40	100	82	954	10,0	102	10,0	216	76,5	PHP 4SPB1000TB
1250	1257	4	4545	55	110	82	1204	16,0	114	16,0	225	162,0	PHP 4SPB1250TB

Dimensions in mm unless otherwise stated

* Weights do not include bushings

Non-functional dimensions may vary slightly

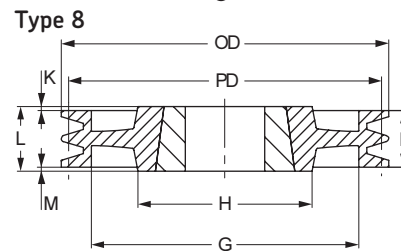
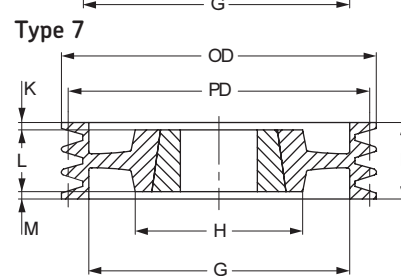
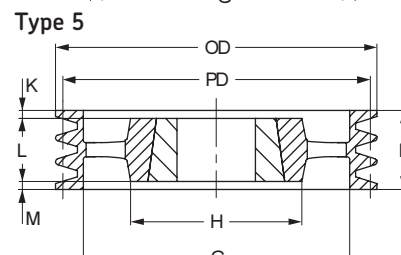
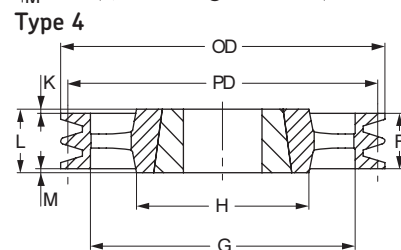
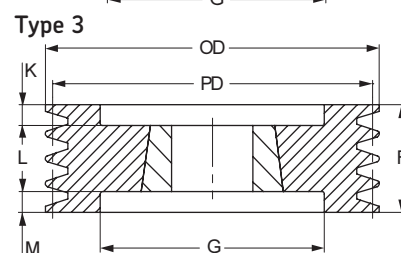
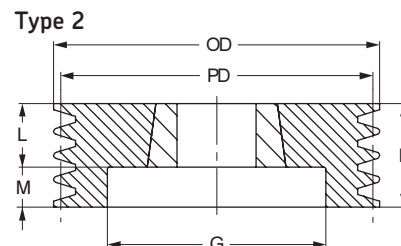



Wedge belt pulleys

SPB taper bushed



5 Groove SPB

Pitch Diameter	OD	Pulley Type	Bush No.	Bore		F	G	K	L	M	H	Weight*	Designation
				Min	Max								
mm	mm			mm	mm	mm	mm	mm	mm	mm	mm	kg	
125	132	6	2012	14	50	101	87	69,0	32	-	-	3,6	PHP 5SPB125TB
132	139	6	2517	16	60	101	94	56,0	45	-	-	3,8	PHP 5SPB132TB
140	147	3	2517	16	60	101	97	28,0	45	28,0	-	4,2	PHP 5SPB140TB
150	157	3	2517	16	60	101	107	28,0	45	28,0	-	5,7	PHP 5SPB150TB
160	167	3	2517	16	60	101	117	28,0	45	28,0	-	6,7	PHP 5SPB160TB
170	177	3	3020	25	75	101	127	25,0	51	25,0	-	6,7	PHP 5SPB170TB
180	187	3	3020	25	75	101	137	25,0	51	25,0	-	7,8	PHP 5SPB180TB
190	197	3	3020	25	75	101	147	25,0	51	25,0	-	9,1	PHP 5SPB190TB
200	207	3	3020	25	75	101	157	25,0	51	25,0	-	10,3	PHP 5SPB200TB
212	219	3	3020	25	75	101	169	25,0	51	25,0	-	12,2	PHP 5SPB212TB
224	231	3	3020	25	75	101	181	25,0	51	25,0	-	13,7	PHP 5SPB224TB
236	243	3	3535	35	90	101	193	6,0	89	6,0	-	15,9	PHP 5SPB236TB
250	257	3	3535	35	90	101	207	6,0	89	6,0	-	18,6	PHP 5SPB250TB
280	287	7	3535	35	90	101	237	6,0	89	6,0	170	21,4	PHP 5SPB280TB
300	307	7	3535	35	90	101	257	6,0	89	6,0	170	22,5	PHP 5SPB300TB
315	322	7	3535	35	90	101	272	6,0	89	6,0	170	22,3	PHP 5SPB315TB
335	342	7	3535	35	90	101	292	6,0	89	6,0	170	24,0	PHP 5SPB335TB
355	362	7	3535	35	90	101	312	6,0	89	6,0	170	25,5	PHP 5SPB355TB
400	407	5	3535	35	90	101	357	6,0	89	6,0	170	30,2	PHP 5SPB400TB
450	457	5	3535	35	90	101	407	-	89	12,0	170	32,8	PHP 5SPB450TB
500	507	5	3535	35	90	101	457	-	89	12,0	170	36,7	PHP 5SPB500TB
560	567	4	4040	40	100	101	517	-	102	1,0	200	45,6	PHP 5SPB560TB
630	637	4	4040	40	100	101	587	-	102	1,0	200	50,0	PHP 5SPB630TB
710	717	4	4040	40	100	101	664	0,5	102	0,5	200	63,5	PHP 5SPB710TB
800	807	4	4040	40	100	101	754	0,5	102	0,5	200	67,0	PHP 5SPB800TB
900	907	4	4040	40	100	101	854	6,5	114	6,5	200	103,0	PHP 5SPB900TB
1000	1007	4	4545	55	110	101	954	6,5	114	6,5	225	110,0	PHP 5SPB1000TB
1250	1257	4	4545	55	110	101	1204	6,5	114	6,5	225	180,0	PHP 5SPB1250TB

6 Groove SPB

Pitch Diameter	OD	Pulley Type	Bush No.	Bore		F	G	K	L	M	H	Weight*	Designation
				Min	Max								
mm	mm			mm	mm	mm	mm	mm	mm	mm	mm	kg	
125	132	3	2012	14	50	120	85	44,0	32	44,0	-	4,2	PHP 6SPB125TB
132	139	3	2012	14	50	120	92	44,0	32	44,0	-	4,5	PHP 6SPB132TB
140	147	3	2517	16	60	120	97	37,5	45	37,5	-	4,7	PHP 6SPB140TB
150	157	3	2517	16	60	120	107	37,5	45	37,5	-	6,5	PHP 6SPB150TB
160	167	3	3020	25	75	120	117	34,5	51	34,5	-	5,9	PHP 6SPB160TB
170	177	3	3020	25	75	120	127	34,5	51	34,5	-	7,6	PHP 6SPB170TB
180	187	3	3020	25	75	120	137	34,5	51	34,5	-	8,9	PHP 6SPB180TB
190	197	3	3020	25	75	120	147	34,5	51	34,5	-	10,2	PHP 6SPB190TB
200	207	3	3020	25	75	120	157	34,5	51	34,5	-	11,7	PHP 6SPB200TB
212	219	3	3535	35	90	120	169	15,5	89	15,5	-	13,2	PHP 6SPB212TB
224	231	3	3535	35	90	120	181	15,5	89	15,5	-	15,2	PHP 6SPB224TB
236	243	3	3535	35	90	120	193	15,5	89	15,5	-	17,6	PHP 6SPB236TB
250	257	3	3535	35	90	120	207	15,5	89	15,5	-	20,2	PHP 6SPB250TB
280	287	7	3535	35	90	120	237	15,5	89	15,5	191	23,5	PHP 6SPB280TB
300	307	7	3535	35	90	120	257	15,5	89	15,5	191	24,0	PHP 6SPB300TB
315	322	7	3535	35	90	120	272	15,5	89	15,5	191	24,1	PHP 6SPB315TB
335	342	7	3535	35	90	120	292	15,5	89	15,5	191	26,0	PHP 6SPB335TB
355	362	7	3535	35	90	120	312	15,5	89	15,5	191	28,3	PHP 6SPB355TB
400	407	5	3535	35	90	120	357	15,5	89	15,5	191	31,8	PHP 6SPB400TB
450	457	5	4040	40	100	120	407	-	102	18,0	191	35,3	PHP 6SPB450TB
500	507	5	4040	40	100	120	457	-	102	18,0	191	40,7	PHP 6SPB500TB
560	567	5	4040	40	100	120	517	-	102	18,0	191	49,2	PHP 6SPB560TB
630	637	5	4040	40	100	120	587	-	102	18,0	191	53,5	PHP 6SPB630TB
710	717	5	4040	40	100	120	664	9,0	102	9,0	240	69,0	PHP 6SPB710TB
800	807	5	4545	55	110	120	754	3,0	114	3,0	240	84,5	PHP 6SPB800TB
900	907	5	4545	55	110	120	854	3,0	114	3,0	240	94,5	PHP 6SPB900TB
1000	1007	5	4545	55	110	120	954	3,0	114	3,0	240	104,0	PHP 6SPB1000TB
1250	1257	4	4545	55	110	120	1204	3,5	127	3,5	265	210,0	PHP 6SPB1250TB

Dimensions in mm unless otherwise stated
 * Weights do not include bushings
 Non-functional dimensions may vary slightly

Type 3

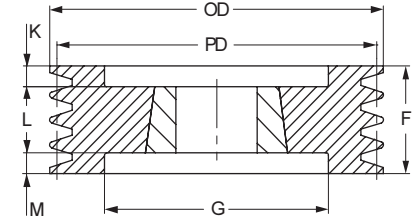

Type 4

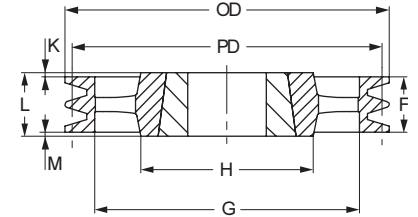

Type 5

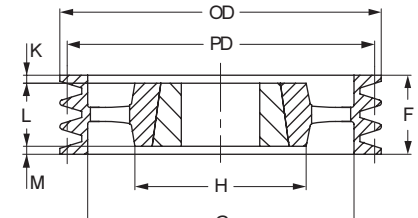

Type 6

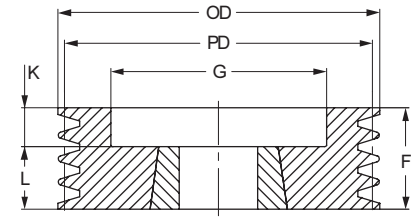

Type 7

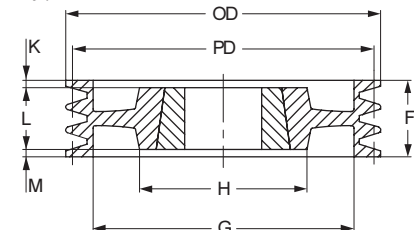



Wedge belt pulleys

SPB taper bushed

- ▶ Belts
- ▶ Chains
- ▶ Couplings
- ▶ Bushings and Hubs
- ▶ Sprockets
- ▶ Pulleys
- ▶ Smart tools

8 Groove SPB

Pitch Diameter	OD	Pulley Type	Bush No.	Bore		F	G	K	L	M	H	Weight*	Designation
				Min	Max								
140	147	3	2517	16	60	158	97	56,5	45	56,5	-	6,8	PHP 8SPB140TB
160	167	3	3020	25	75	158	117	53,5	51	53,5	-	8,3	PHP 8SPB160TB
170	177	3	3030	35	75	158	127	41,0	76	41,0	-	9,5	PHP 8SPB170TB
180	187	3	3030	35	75	158	137	41,0	76	41,0	-	10,8	PHP 8SPB180TB
190	197	3	3030	35	75	158	147	41,0	76	41,0	-	12,3	PHP 8SPB190TB
200	207	3	3535	35	90	158	157	34,5	89	34,5	-	13,7	PHP 8SPB200TB
212	219	3	3535	35	90	158	169	34,5	89	34,5	-	15,8	PHP 8SPB212TB
224	231	3	3535	35	90	158	181	34,5	89	34,5	-	17,9	PHP 8SPB224TB
236	243	3	3535	35	90	158	193	34,5	89	34,5	-	20,0	PHP 8SPB236TB
250	257	3	3535	35	90	158	207	34,5	89	34,5	-	23,2	PHP 8SPB250TB
280	287	3	3535	35	90	158	237	34,5	89	34,5	-	26,6	PHP 8SPB280TB
300	307	6	3535	35	90	158	257	34,5	89	34,5	170	27,3	PHP 8SPB300TB
315	322	6	3535	35	90	158	272	34,5	89	34,5	170	28,0	PHP 8SPB315TB
335	342	6	3535	35	90	158	292	34,5	89	34,5	170	30,5	PHP 8SPB335TB
355	362	6	3535	35	90	158	312	34,5	89	34,5	170	31,5	PHP 8SPB355TB
400	407	5	4040	40	100	158	357	28,0	102	28,0	200	43,0	PHP 8SPB400TB
450	457	5	4040	40	100	158	407	28,0	102	28,0	200	46,0	PHP 8SPB450TB
500	507	5	4040	40	100	158	457	28,0	102	28,0	200	52,0	PHP 8SPB500TB
560	567	5	4545	55	110	158	517	22,0	114	22,0	225	54,5	PHP 8SPB560TB
630	637	5	4545	55	110	158	587	22,0	114	22,0	225	67,0	PHP 8SPB630TB
710	717	5	4545	55	110	158	664	22,0	114	22,0	225	75,5	PHP 8SPB710TB
800	807	5	4545	55	110	158	754	22,0	114	22,0	225	94,5	PHP 8SPB800TB
900	907	5	4545	55	110	158	854	22,0	114	22,0	225	113,5	PHP 8SPB900TB
1000	1007	5	5050	70	125	158	954	15,5	127	15,5	245	121,5	PHP 8SPB1000TB
1250	1257	5	5050	70	125	158	1204	15,5	127	15,5	245	242,0	PHP 8SPB1250TB

Type 3

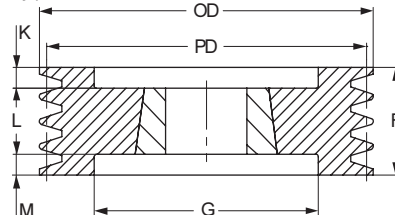

Type 5

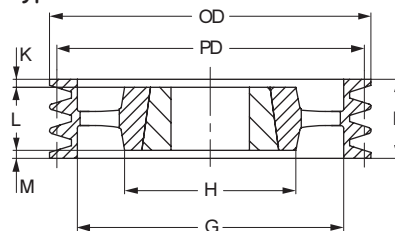

Type 7

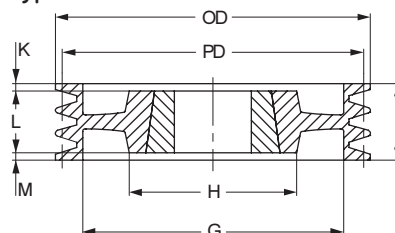

Type 6

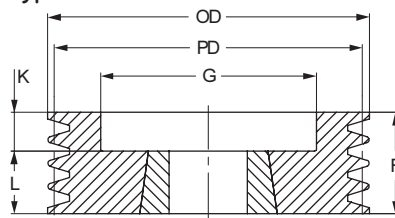

10 Groove SPB

Pitch Diameter	OD	Pulley Type	Bush No.	Bore		F	G	K	L	M	H	Weight*	Designation
				Min	Max								
224	231	3	3535	35	90	196	181	53,5	89	53,5	-	20,5	PHP 10SPB224TB
236	243	3	3535	35	90	196	193	53,5	89	53,5	-	22,6	PHP 10SPB236TB
250	257	3	3535	35	90	196	207	53,5	89	53,5	-	26,6	PHP 10SPB250TB
280	287	3	3535	35	90	196	237	53,5	89	53,5	-	27,8	PHP 10SPB280TB
315	322	7	3535	35	90	196	272	53,5	89	53,5	170	28,8	PHP 10SPB315TB
335	342	7	4040	40	100	196	292	47,0	102	47,0	200	32,0	PHP 10SPB335TB
355	362	7	4040	40	100	196	312	47,0	102	47,0	200	33,5	PHP 10SPB355TB
400	407	5	4040	40	100	196	357	47,0	102	47,0	200	36,0	PHP 10SPB400TB
450	457	5	4545	55	110	196	407	41,0	114	41,0	225	47,0	PHP 10SPB450TB
500	507	5	4545	55	110	196	457	41,0	114	41,0	225	55,0	PHP 10SPB500TB
560	567	5	4545	55	110	196	517	41,0	114	41,0	225	59,0	PHP 10SPB560TB
630	637	5	4545	55	110	196	587	41,0	114	41,0	225	66,0	PHP 10SPB630TB
710	717	5	4545	55	125	196	664	41,0	114	41,0	225	75,0	PHP 10SPB710TB
800	807	5	4545	55	125	196	754	41,0	114	41,0	225	96,0	PHP 10SPB800TB
900	907	5	5050	70	125	196	854	34,5	127	34,5	245	119,0	PHP 10SPB900TB
1000	1007	5	5050	70	125	196	954	34,5	127	34,5	245	141,0	PHP 10SPB1000TB
1250	1257	5	5050	70	125	196	1203	35,0	127	-	-	265,0	PHP 10SPB1250TB

Dimensions in mm unless otherwise stated

* Weights do not include bushings

Non-functional dimensions may vary slightly



Wedge belt pulleys

SPC taper bushed



3 Groove SPC

Pitch Diameter	OD	Pulley Type	Bush No.	Bore		F	G	K	L	M	H	Weight*	Designation
				Min	Max								
mm	mm			mm	mm	mm	mm	mm	mm	mm	mm	kg	
200	209,6	3	2517	16	60	85	150	20,0	45	20,0	-	10,2	PHP 3SPC200TB
212	221,6	3	3020	25	75	85	162	17,0	51	17,0	-	11,2	PHP 3SPC212TB
224	233,6	3	3020	25	75	85	173	17,0	51	17,0	-	12,7	PHP 3SPC224TB
236	245,6	3	3020	25	75	85	185	17,0	51	17,0	-	14,4	PHP 3SPC236TB
250	259,6	3	3020	25	75	85	100	17,0	51	17,0	-	16,5	PHP 3SPC250TB
265	274,6	1	3535	35	90	85	209	-	89	4,0	170	19,7	PHP 3SPC265TB
280	289,6	1	3535	35	90	85	224	-	89	4,0	170	22,7	PHP 3SPC280TB
300	309,6	7	3535	35	90	85	249	2,0	89	2,0	170	22,7	PHP 3SPC300TB
315	324,6	7	3535	35	90	85	264	2,0	89	2,0	170	22,0	PHP 3SPC315TB
335	344,6	7	3535	35	90	85	284	2,0	89	2,0	170	24,1	PHP 3SPC335TB
355	364,6	7	3535	35	90	85	304	2,0	89	2,0	170	26,2	PHP 3SPC355TB
375	384,6	7	3535	35	90	85	324	2,0	89	2,0	170	28,0	PHP 3SPC375TB
400	409,6	4	3535	35	90	85	344	2,0	89	2,0	170	29,3	PHP 3SPC400TB
425	434,6	4	3535	35	90	85	369	2,0	89	2,0	170	32,8	PHP 3SPC425TB
450	459,6	4	3535	35	90	85	394	2,0	89	2,0	170	34,7	PHP 3SPC450TB
475	484,6	4	3535	35	90	85	419	2,0	89	2,0	170	36,5	PHP 3SPC475TB
500	509,6	4	3535	35	90	85	444	2,0	89	2,0	170	40,0	PHP 3SPC500TB
530	539,6	4	3535	35	90	85	474	2,0	89	2,0	170	42,5	PHP 3SPC530TB
560	569,6	4	3535	35	90	85	504	2,0	89	2,0	170	45,9	PHP 3SPC560TB
630	639,6	4	4040	40	100	85	574	8,5	102	8,5	200	76,3	PHP 3SPC630TB
710	719,6	4	4040	40	100	85	654	8,5	102	8,5	200	81,6	PHP 3SPC710TB
800	809,6	4	4545	55	110	85	737	14,5	114	14,5	225	87,0	PHP 3SPC800TB
1000	1009,6	4	5050	70	125	85	937	21,0	127	21,0	245	120,0	PHP 3SPC1000TB
1250	1259,6	4	5050	70	125	85	1187	21,0	127	21,0	245	175,0	PHP 3SPC1250TB

Type 1

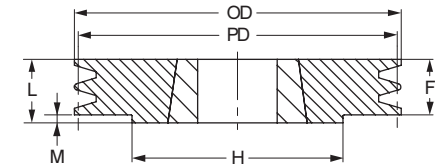

Type 3

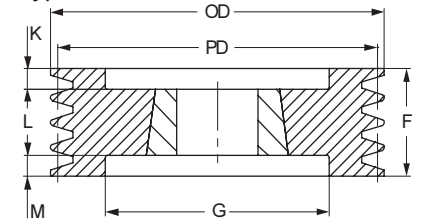

Type 4

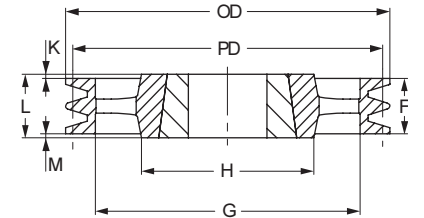

Type 5

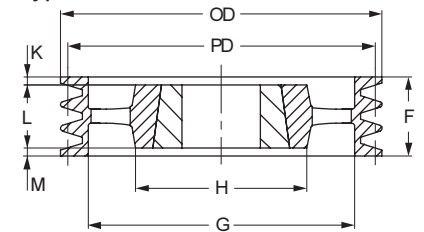

Type 7

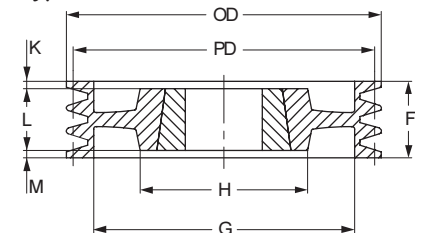

4 Groove SPC

Pitch Diameter	OD	Pulley Type	Bush No.	Bore		F	G	K	L	M	H	Weight*	Designation
				Min	Max								
mm	mm			mm	mm	mm	mm	mm	mm	mm	mm	kg	
200	209,6	3	3020	25	75	111	144	30,0	51	30,0	-	11,3	PHP 4SPC200TB
212	221,6	3	3020	25	75	111	156	30,0	51	30,0	-	13,0	PHP 4SPC212TB
224	233,6	3	3535	35	90	111	168	11,0	89	11,0	-	14,5	PHP 4SPC224TB
236	245,6	3	3535	35	90	111	180	11,0	89	11,0	-	16,7	PHP 4SPC236TB
250	259,6	3	3535	35	90	111	194	11,0	89	11,0	-	19,3	PHP 4SPC250TB
265	274,6	3	3535	35	90	111	209	11,0	89	11,0	-	22,4	PHP 4SPC265TB
280	289,6	3	3535	35	90	111	224	11,0	89	11,0	-	25,4	PHP 4SPC280TB
300	309,6	7	3535	35	90	111	244	11,0	89	11,0	170	25,4	PHP 4SPC300TB
315	324,6	7	3535	35	90	111	259	11,0	89	11,0	170	25,3	PHP 4SPC315TB
335	344,6	7	3535	35	90	111	279	11,0	89	11,0	170	27,4	PHP 4SPC335TB
355	364,6	7	3535	35	90	111	299	11,0	89	11,0	170	29,6	PHP 4SPC355TB
375	384,6	7	3535	35	90	111	319	11,0	89	11,0	170	31,3	PHP 4SPC375TB
400	409,6	5	3535	35	90	111	344	11,0	89	11,0	170	33,8	PHP 4SPC400TB
425	434,6	5	3535	35	90	111	369	11,0	89	11,0	170	38,0	PHP 4SPC425TB
450	459,6	5	3535	35	90	111	394	11,0	89	11,0	170	41,3	PHP 4SPC450TB
475	484,6	5	3535	35	90	111	419	11,0	89	11,0	170	43,7	PHP 4SPC475TB
500	509,6	5	3535	35	90	111	444	11,0	89	11,0	170	46,0	PHP 4SPC500TB
530	539,6	5	4040	40	100	111	474	4,5	102	4,5	170	52,0	PHP 4SPC530TB
560	569,6	5	4040	40	100	111	504	4,5	102	4,5	200	58,0	PHP 4SPC560TB
630	639,6	4	4545	55	110	111	574	1,5	114	1,5	225	63,8	PHP 4SPC630TB
710	719,6	4	5050	70	125	111	654	4,0	127	12,0	245	83,2	PHP 4SPC710TB
800	809,6	4	5050	70	125	111	737	4,0	127	12,0	245	102,5	PHP 4SPC800TB
1000	1009,6	4	5050	70	125	111	937	4,0	127	12,0	245	130,0	PHP 4SPC1000TB
1250	1259,6	4	5050	70	125	111	1187	4,0	127	12,0	245	186,0	PHP 4SPC1250TB

Dimensions in mm unless otherwise stated

* Weights do not include bushings

Non-functional dimensions may vary slightly



Wedge belt pulleys

SPC taper bushed

- ▶ Belts
- ▶ Chains
- ▶ Couplings
- ▶ Bushings and Hubs
- ▶ Sprockets
- ▶ Pulleys
- ▶ Smart tools

5 Groove SPC

Pitch Diameter	OD	Pulley Type	Bush No.	Bore		F	G	K	L	M	H	Weight*	Designation
				Min	Max								
200	209,6	3	3535	35	90	136	150	23,5	89	23,5	-	12,2	PHP 5SPC200TB
212	221,6	3	3535	35	90	136	160	23,5	89	23,5	-	14,5	PHP 5SPC212TB
224	233,6	3	3535	35	90	136	173	23,5	89	23,5	-	16,6	PHP 5SPC224TB
236	245,6	3	3535	35	90	136	185	23,5	89	23,5	-	18,9	PHP 5SPC236TB
250	259,6	3	3535	35	90	136	198	23,5	89	23,5	-	21,5	PHP 5SPC250TB
265	274,6	3	3535	35	90	136	213	23,5	89	23,5	-	25,0	PHP 5SPC265TB
280	289,6	3	3535	35	90	136	228	23,5	89	23,5	-	28,4	PHP 5SPC280TB
300	309,6	7	3535	35	90	136	247	23,5	89	23,5	170	28,2	PHP 5SPC300TB
315	324,6	7	3535	35	90	136	264	23,5	89	23,5	170	28,1	PHP 5SPC315TB
335	344,6	7	3535	35	90	136	280	23,5	89	23,5	170	31,1	PHP 5SPC335TB
355	364,6	7	3535	35	90	136	304	23,5	89	23,5	170	33,1	PHP 5SPC355TB
375	384,6	7	3535	35	90	136	324	23,5	89	23,5	170	35,6	PHP 5SPC375TB
400	409,6	5	3535	35	90	136	344	23,5	89	23,5	170	38,5	PHP 5SPC400TB
425	434,6	5	3535	35	90	136	369	23,5	89	23,5	170	42,5	PHP 5SPC425TB
450	459,6	5	4040	40	100	136	394	17,0	102	17,0	200	44,3	PHP 5SPC450TB
475	484,6	5	4040	40	100	136	419	17,0	102	17,0	200	48,5	PHP 5SPC475TB
500	509,6	5	4040	40	100	136	444	17,0	102	17,0	200	51,0	PHP 5SPC500TB
530	539,6	5	4545	55	110	136	474	17,0	102	17,0	200	66,0	PHP 5SPC530TB
560	569,6	5	4545	55	110	136	504	11,0	114	11,0	200	66,7	PHP 5SPC560TB
630	639,6	5	5050	70	125	136	574	4,5	127	4,5	245	73,0	PHP 5SPC630TB
710	719,6	5	5050	70	125	136	654	4,5	127	4,5	245	93,0	PHP 5SPC710TB
800	809,6	5	5050	70	125	136	737	4,5	127	4,5	245	119,0	PHP 5SPC800TB
1000	1009,6	5	5050	70	125	136	937	4,5	127	4,5	245	147,0	PHP 5SPC1000TB
1250	1259,6	5	5050	70	125	136	1187	4,5	127	4,5	245	210,0	PHP 5SPC1250TB

Type 3

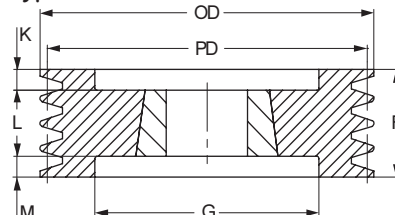

Type 5

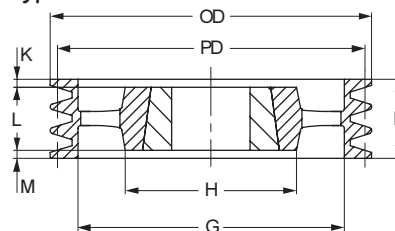

6 Groove SPC

Pitch Diameter	OD	Pulley Type	Bush No.	Bore		F	G	K	L	M	H	Weight*	Designation
				Min	Max								
200	209,6	3	3535	35	90	162	148	36,5	89	36,5	-	14,1	PHP 6SPC200TB
212	221,6	3	3535	35	90	162	160	36,5	89	36,5	-	16,5	PHP 6SPC212TB
224	233,6	3	3535	35	90	162	173	36,5	89	36,5	-	18,0	PHP 6SPC224TB
236	245,6	3	3535	35	90	162	185	36,5	89	36,5	-	21,3	PHP 6SPC236TB
250	259,6	3	3535	35	90	162	198	36,5	89	36,5	-	29,0	PHP 6SPC250TB
265	274,6	3	3535	35	90	162	213	36,5	89	36,5	-	30,3	PHP 6SPC265TB
280	289,6	7	3535	35	90	162	228	36,5	89	36,5	-	31,5	PHP 6SPC280TB
300	309,6	7	3535	35	90	162	247	36,5	89	36,5	170	31,5	PHP 6SPC300TB
315	324,6	7	3535	35	90	162	264	36,5	89	36,5	170	33,2	PHP 6SPC315TB
335	344,6	7	3535	35	90	162	280	36,5	89	36,5	170	37,5	PHP 6SPC335TB
355	364,6	7	3535	35	90	162	304	36,5	89	36,5	170	40,5	PHP 6SPC355TB
375	384,6	7	4040	40	100	162	324	30,0	102	30,0	200	44,5	PHP 6SPC375TB
400	409,6	7	4040	40	100	162	348	30,0	102	30,0	200	48,0	PHP 6SPC400TB
425	434,6	7	4040	40	100	162	369	30,0	102	30,0	225	51,0	PHP 6SPC425TB
450	459,6	7	4545	55	110	162	394	24,0	114	24,0	225	57,5	PHP 6SPC450TB
475	484,6	7	4545	55	110	162	419	24,0	114	24,0	225	62,0	PHP 6SPC475TB
500	509,6	5	4545	55	110	162	444	24,0	114	24,0	225	67,0	PHP 6SPC500TB
530	539,6	5	5050	70	125	162	474	17,5	114	17,5	245	74,5	PHP 6SPC530TB
560	569,6	5	5050	70	125	162	504	24,0	127	24,0	245	77,5	PHP 6SPC560TB
630	639,6	5	5050	70	125	162	574	17,5	127	17,5	245	88,5	PHP 6SPC630TB
710	719,6	5	5050	70	125	162	654	17,5	127	17,5	245	107,3	PHP 6SPC710TB
800	809,6	5	5050	70	125	162	737	17,5	127	17,5	245	126,0	PHP 6SPC800TB
1000	1009,6	5	5050	70	125	162	937	17,5	127	17,5	245	185,0	PHP 6SPC1000TB
1250	1259,6	5	5050	70	125	162	1187	17,5	127	17,5	245	258,0	PHP 6SPC1250TB

Type 7

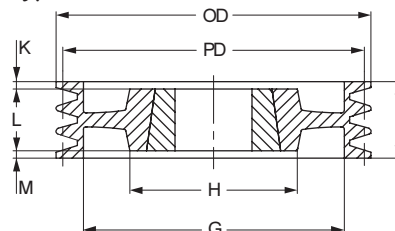

Dimensions in mm unless otherwise stated
 * Weights do not include bushings
 Non-functional dimensions may vary slightly



Wedge belt pulleys

SPC taper bushed



8 Groove SPC

Pitch Diameter	OD	Pulley Type	Bush No.	Bore		F	G	K	L	M	H	Weight*	Designation
				Min	Max								
mm	mm			mm	mm	mm	mm	mm	mm	mm	mm	kg	
200	209,6	3	3535	35	90	213	148	62,0	89	62,0	-	20,0	PHP 8SPC200TB
212	221,6	3	3535	35	90	213	160	62,0	89	62,0	-	21,3	PHP 8SPC212TB
224	233,6	3	3535	35	90	213	170	62,0	89	62,0	-	22,9	PHP 8SPC224TB
236	245,6	3	3535	35	90	213	184	62,0	89	62,0	-	25,9	PHP 8SPC236TB
250	259,6	3	3535	35	90	213	198	62,0	89	62,0	-	29,0	PHP 8SPC250TB
265	274,6	3	3535	35	90	213	213	62,0	89	62,0	-	32,5	PHP 8SPC265TB
280	289,6	3	3535	35	90	213	228	62,0	89	62,0	-	36,1	PHP 8SPC280TB
300	309,6	3	4040	40	100	213	207	55,5	102	55,5	-	37,1	PHP 8SPC300TB
315	324,6	3	4040	40	100	213	258	55,5	102	55,5	-	40,0	PHP 8SPC315TB
335	344,6	7	4040	40	100	213	280	55,5	102	55,5	-	44,0	PHP 8SPC335TB
355	364,6	3	4040	40	100	213	304	55,5	102	55,5	-	49,0	PHP 8SPC355TB
375	384,6	3	4545	55	110	213	324	49,5	114	49,5	-	54,5	PHP 8SPC375TB
400	409,6	7	4545	55	110	213	348	49,5	114	49,5	220	58,0	PHP 8SPC400TB
425	434,6	7	4545	55	110	213	369	49,5	114	49,5	245	63,5	PHP 8SPC425TB
450	459,6	7	5050	70	125	213	394	43,0	127	43,0	245	70,0	PHP 8SPC450TB
475	484,6	7	5050	70	125	213	419	43,0	127	43,0	245	72,0	PHP 8SPC475TB
500	509,6	7	5050	70	125	213	444	43,0	127	43,0	245	82,5	PHP 8SPC500TB
530	539,6	7	5050	70	125	213	474	43,0	127	43,0	245	82,5	PHP 8SPC530TB
560	569,6	5	5050	70	125	213	504	43,0	127	43,0	245	94,5	PHP 8SPC560TB
630	639,6	5	5050	70	125	213	574	43,0	127	43,0	245	102,0	PHP 8SPC630TB
710	719,6	5	5050	70	125	213	656	43,0	127	43,0	245	123,5	PHP 8SPC710TB
800	809,6	5	5050	70	125	213	737	43,0	127	43,0	245	145,0	PHP 8SPC800TB
1000	1009,6	5	5050	70	125	213	937	43,0	127	43,0	245	207,0	PHP 8SPC1000TB
1250	1259,6	5	5050	70	125	213	1187	43,0	127	43,0	245	285,0	PHP 8SPC1250TB

Type 3

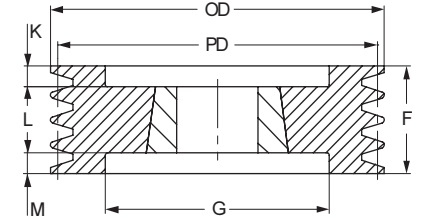

Type 5

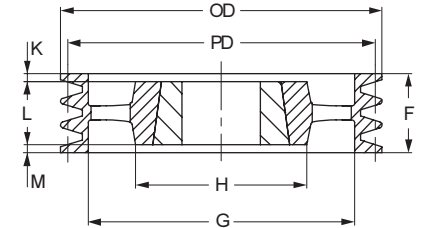

10 Groove SPC

Pitch Diameter	OD	Pulley Type	Bush No.	Bore		F	G	K	L	M	H	Weight*	Designation
				Min	Max								
mm	mm			mm	mm	mm	mm	mm	mm	mm	mm	kg	
224	233,6	3	4040	40	100	264	168	81,0	102	-	-	28,0	PHP 10SPC224TB
236	246,0	3	4040	40	100	264	180	81,0	102	81,0	-	30,9	PHP 10SPC236TB
250	259,6	3	4040	40	100	264	196	81,0	102	81,0	-	35,0	PHP 10SPC250TB
265	274,6	3	4040	40	100	264	209	81,0	102	81,0	-	39,5	PHP 10SPC265TB
280	289,6	3	4040	40	100	264	226	81,0	102	81,0	-	42,1	PHP 10SPC280TB
300	309,6	3	4545	55	110	264	245	75,0	114	75,0	-	44,1	PHP 10SPC300TB
315	324,6	3	4545	55	110	264	258	75,0	114	75,0	-	47,0	PHP 10SPC315TB
335	344,6	3	4545	55	110	264	279	75,0	114	75,0	-	51,0	PHP 10SPC335TB
355	364,6	3	4545	55	110	264	299	75,0	114	75,0	-	57,0	PHP 10SPC355TB
375	384,6	3	5050	70	125	264	319	68,5	127	68,5	245	62,5	PHP 10SPC375TB
400	409,6	3	5050	70	125	264	342	68,5	127	68,5	245	66,0	PHP 10SPC400TB
425	434,6	7	5050	70	125	264	369	68,5	127	68,5	245	70,5	PHP 10SPC425TB
450	459,6	7	5050	70	125	264	394	68,5	127	68,5	245	78,0	PHP 10SPC450TB
475	484,6	7	5050	70	125	264	419	68,5	127	68,5	245	82,0	PHP 10SPC475TB
500	509,6	7	5050	70	125	264	444	68,5	127	68,5	245	95,5	PHP 10SPC500TB
530	539,6	7	5050	70	125	264	474	68,5	127	68,5	245	106,0	PHP 10SPC530TB
560	569,6	5	5050	70	125	264	504	68,5	127	68,5	245	94,7	PHP 10SPC560TB
630	639,6	5	5050	70	125	264	574	68,5	127	68,5	245	113,2	PHP 10SPC630TB
710	719,6	5	5050	70	125	264	654	68,5	127	68,5	245	133,5	PHP 10SPC710TB
800	809,6	5	5050	70	125	264	737	68,5	127	68,5	245	160,5	PHP 10SPC800TB
1000	1009,6	5	5050	70	125	264	937	68,5	127	68,5	245	227,5	PHP 10SPC1000TB
1250	1259,6	5	5050	70	125	264	1187	68,5	127	68,5	245	300,0	PHP 10SPC1250TB

Dimensions in mm unless otherwise stated

* Weights do not include bushings

Non-functional dimensions may vary slightly

Type 7

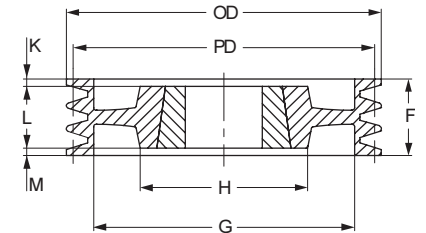



Classical V-belt pulleys

A/B taper bushed

- ▶ Belts
- ▶ Chains
- ▶ Couplings
- ▶ Bushings and Hubs
- ▶ Sprockets
- ▶ Pulleys
- ▶ Smart tools

Type A-1

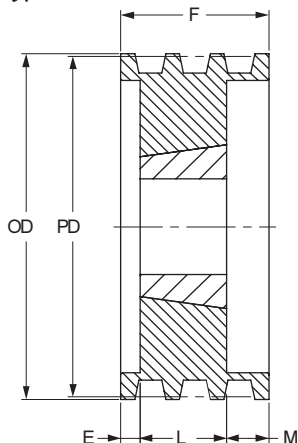

Type A-2

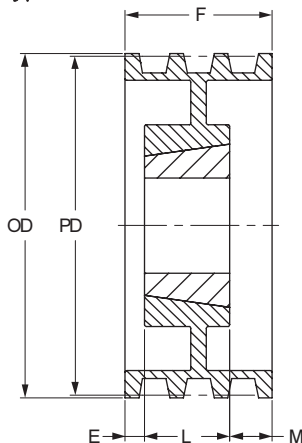

Type B-1

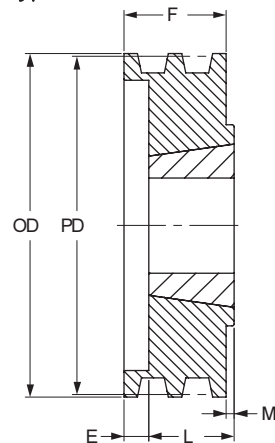

Type B-2

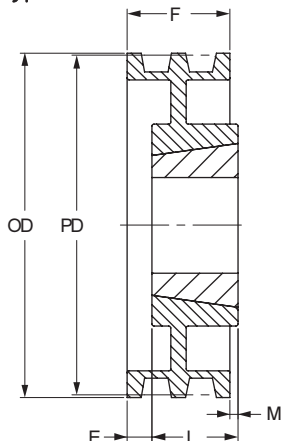

Type C-3

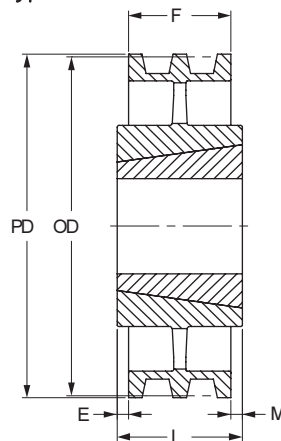

1 Groove

2 Groove

Pitch Diameter		Outside Diameter	Type	Bush	Bore		F	E	L	M	Weight	Designation	Type	Bush	Bore		F	E	L	M	Weight	Designation
A Belt	B Belt				Min	Max									Min	Max						
Inch	Inch	Inch			Inch	Inch	Inch	Inch	Inch	Inch	lbs				Inch	Inch	Inch	Inch	Inch	Inch	lbs	
3,0	3,4	3,75	A-1	1210	5/8	1 1/4	1	-	1	-	2,2	PHP 1-B34TB	A-1	1210	5/8	1 1/4	1 3/4	3/4	1	-	2,2	PHP 2-B34TB
3,2	3,6	3,95	A-1	1210	5/8	1 1/4	1	-	1	-	2,6	PHP 1-B36TB	A-1	1210	5/8	1 1/4	1 3/4	3/4	1	-	2,6	PHP 2-B36TB
3,4	3,8	4,15	A-1	1610	1/2	1 5/8	1	-	1	-	2,8	PHP 1-B38TB	A-1	1610	1/2	1 5/8	1 3/4	3/4	1	-	2,8	PHP 2-B38TB
3,6	4,0	4,35	A-1	1610	1/2	1 5/8	1	-	1	-	3,0	PHP 1-B40TB	A-1	1610	1/2	1 5/8	1 3/4	3/4	1	-	3,0	PHP 2-B40TB
3,8	4,2	4,55	A-1	1610	1/2	1 5/8	1	-	1	-	3,5	PHP 1-B42TB	A-1	1610	1/2	1 5/8	1 3/4	3/4	1	-	4,0	PHP 2-B42TB
4,0	4,4	4,75	A-1	1610	1/2	1 5/8	1	-	1	-	3,8	PHP 1-B44TB	A-1	1610	1/2	1 5/8	1 3/4	3/4	1	-	4,5	PHP 2-B44TB
4,2	4,6	4,95	A-1	1610	1/2	1 5/8	1	-	1	-	4,0	PHP 1-B46TB	A-1	1610	1/2	1 5/8	1 3/4	3/4	1	-	5,0	PHP 2-B46TB
4,4	4,8	5,15	A-1	1610	1/2	1 5/8	1	-	1	-	4,5	PHP 1-B48TB	A-1	1610	1/2	1 5/8	1 3/4	3/4	1	-	5,5	PHP 2-B48TB
4,6	5,0	5,35	A-1	1610	1/2	1 5/8	1	-	1	-	4,8	PHP 1-B50TB	A-1	1610	1/2	1 5/8	1 3/4	3/4	1	-	6,0	PHP 2-B50TB
4,8	5,2	5,55	A-1	1610	1/2	1 5/8	1	-	1	-	5,0	PHP 1-B52TB	A-1	1610	1/2	1 5/8	1 3/4	3/4	1	-	6,5	PHP 2-B52TB
5,0	5,4	5,75	A-1	1610	1/2	1 5/8	1	-	1	-	5,5	PHP 1-B54TB	A-1	1610	1/2	1 5/8	1 3/4	3/4	1	-	7,0	PHP 2-B54TB
5,2	5,6	5,95	A-1	1610	1/2	1 5/8	1	-	1	-	6,0	PHP 1-B56TB	A-1	1610	1/2	1 5/8	1 3/4	3/4	1	-	8,2	PHP 2-B56TB
5,4	5,8	6,15	A-1	1610	1/2	1 5/8	1	-	1	-	6,3	PHP 1-B58TB	A-1	1610	1/2	1 5/8	1 3/4	3/4	1	-	8,6	PHP 2-B58TB
5,6	6,0	6,35	A-1	1610	1/2	1 5/8	1	-	1	-	6,7	PHP 1-B60TB	A-1	1610	1/2	1 5/8	1 3/4	3/4	1	-	8,8	PHP 2-B60TB
5,8	6,2	6,55	A-1	1610	1/2	1 5/8	1	-	1	-	7,0	PHP 1-B62TB	A-1	1610	1/2	1 5/8	1 3/4	3/4	1	-	9,0	PHP 2-B62TB
6,0	6,4	6,75	A-1	1610	1/2	1 5/8	1	-	1	-	8,0	PHP 1-B64TB	A-1	1610	1/2	1 5/8	1 3/4	3/4	1	-	10,0	PHP 2-B64TB
6,2	6,6	6,95	A-1	1610	1/2	1 5/8	1	-	1	-	8,5	PHP 1-B66TB	A-1	1610	1/2	1 5/8	1 3/4	3/4	1	-	10,5	PHP 2-B66TB
6,4	6,8	7,15	A-1	1610	1/2	1 5/8	1	-	1	-	9,0	PHP 1-B68TB	A-1	1610	1/2	1 5/8	1 3/4	3/4	1	-	11,0	PHP 2-B68TB
7,0	7,4	7,75	B-1	2517	3/4	2 1/2	1	-	1 3/4	3/4	9,4	PHP 1-B74TB	A-1	2517	3/4	2 1/2	1 3/4	-	1 3/4	-	16,0	PHP 2-B74TB
8,2	8,6	8,95	B-2	2517	3/4	2 1/2	1	-	1 3/4	3/4	12,0	PHP 1-B86TB	A-2	2517	3/4	2 1/2	1 3/4	-	1 3/4	-	18,0	PHP 2-B86TB
9,0	9,4	9,75	B-2	2517	3/4	2 1/2	1	-	1 3/4	3/4	14,0	PHP 1-B94TB	A-2	2517	3/4	2 1/2	1 3/4	-	1 3/4	-	20,0	PHP 2-B94TB
10,6	11,0	11,35	B-2	2517	3/4	2 1/2	1	-	1 3/4	3/4	18,0	PHP 1-B110TB	A-2	2517	3/4	2 1/2	1 3/4	-	1 3/4	-	25,0	PHP 2-B110TB
12,0	12,4	12,75	C-3	2517	3/4	2 1/2	1	1/4	1 3/4	1/2	18,5	PHP 1-B124TB	A-3	2517	3/4	2 1/2	1 3/4	-	1 3/4	-	27,0	PHP 2-B124TB
15,0	15,4	15,75	C-3	2517	3/4	2 1/2	1	1/4	1 3/4	1/2	19,0	PHP 1-B154TB	A-3	2517	3/4	2 1/2	1 3/4	-	1 3/4	-	31,0	PHP 2-B154TB
18,0	18,4	18,75	C-3	2517	3/4	2 1/2	1	1/8	1 3/4	3/16	24,0	PHP 1-B184TB	A-3	2517	3/4	2 1/2	1 3/4	-	1 3/4	-	33,0	PHP 2-B184TB
19,6	20,0	20,35	-	-	-	-	-	-	-	-	-	-	C-3	3020	1 1/4	3	1 3/4	-	2	1/4	49,0	PHP 2-B200TB
24,6	25,0	25,35	-	-	-	-	-	-	-	-	-	-	C-3	3020	1 1/4	3	1 3/4	-	2	1/4	65,0	PHP 2-B250TB
29,6	30,0	30,35	-	-	-	-	-	-	-	-	-	-	C-3	3020	1 1/4	3	1 3/4	-	2	1/4	75,0	PHP 2-B300TB
37,6	38,0	38,35	-	-	-	-	-	-	-	-	-	-	C-3	3020	1 1/4	3	1 3/4	-	2	1/4	112,0	PHP 2-B380TB



Classical V-belt pulleys

A/B taper bushed



Type A-1

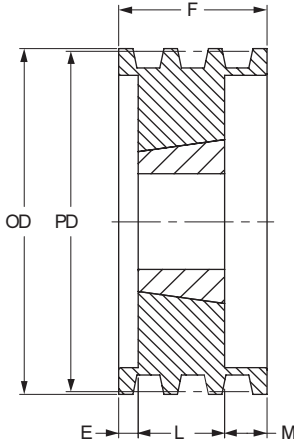

Type A-2

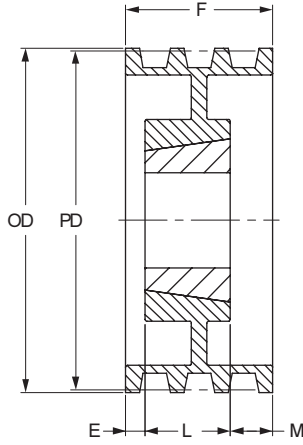

Type A-3

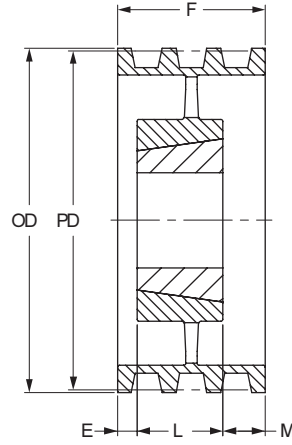

Type B-3

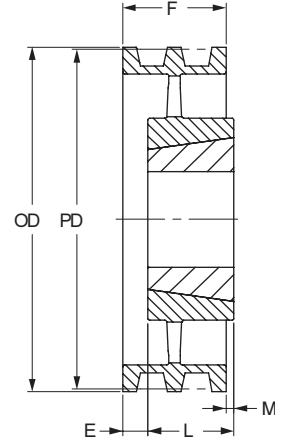

3 Groove

4 Groove

Pitch Diameter		Outside Diameter	Type	Bush	Bore		F	E	L	M	Weight	Designation	Type	Bush	Bore		F	E	L	M	Weight	Designation
A Belt	B Belt				Min	Max									Min	Max						
Inch	Inch	Inch			Inch	Inch	Inch	Inch	Inch	Inch	lbs				Inch	Inch	Inch	Inch	Inch	Inch	lbs	
3,0	3,4	3,75	A-1	1210	5/8	1 1/4	2 1/2	1 1/2	1	-	3,0	PHP 3-B34TB	A-1	1210	5/8	1 1/4	3 1/4	2 1/4	1	-	3,0	PHP 4-B34TB
3,2	3,6	3,95	A-1	1210	5/8	1 1/4	2 1/2	1 1/2	1	-	3,5	PHP 3-B36TB	A-1	1210	5/8	1 1/4	3 1/4	2 1/4	1	-	3,5	PHP 4-B36TB
3,4	3,8	4,15	A-1	1610	3/2	1 5/8	2 1/2	1 1/2	1	-	4,0	PHP 3-B38TB	A-1	1610	3/2	1 5/8	3 3/4	2 1/4	1	-	4,0	PHP 4-B38TB
3,6	4,0	4,35	A-1	1610	3/2	1 5/8	2 1/2	1 1/2	1	-	5,0	PHP 3-B40TB	A-1	1610	3/2	1 5/8	3 3/4	2 1/4	1	-	5,0	PHP 4-B40TB
3,8	4,2	4,55	A-1	1610	3/2	1 5/8	2 1/2	1 1/2	1	-	6,0	PHP 3-B42TB	A-1	1610	3/2	1 5/8	3 3/4	2 1/4	1	-	5,5	PHP 4-B42TB
4,0	4,4	4,75	A-1	1610	3/2	1 5/8	2 1/2	1 1/2	1	-	6,5	PHP 3-B44TB	A-1	1610	3/2	1 5/8	3 3/4	2 1/4	1	-	6,0	PHP 4-B44TB
4,2	4,6	4,95	A-1	1610	3/2	1 5/8	2 1/2	1 1/2	1	-	7,0	PHP 3-B46TB	A-1	1610	3/2	1 5/8	3 3/4	2 1/4	1	-	7,0	PHP 4-B46TB
4,4	4,8	5,15	A-1	1610	3/2	1 5/8	2 1/2	1 1/2	1	-	8,0	PHP 3-B48TB	A-1	1610	3/2	1 5/8	3 3/4	2 1/4	1	-	8,0	PHP 4-B48TB
4,6	5,0	5,35	A-1	1610	3/2	1 5/8	2 1/2	1 1/2	1	-	8,5	PHP 3-B50TB	A-1	2517	3/4	2 1/2	3 1/4	1 1/2	1 3/4	-	8,5	PHP 4-B50TB
4,8	5,2	5,55	A-1	1610	3/2	1 5/8	2 1/2	1 1/2	1	-	9,0	PHP 3-B52TB	A-1	2517	3/4	2 1/2	3 1/4	1 1/2	1 3/4	-	9,0	PHP 4-B52TB
5,0	5,4	5,75	A-1	2517	3/4	2 1/2	2 1/2	1 1/2	1 3/4	-	9,5	PHP 3-B54TB	A-1	2517	3/4	2 1/2	3 1/4	1 1/2	1 3/4	-	9,5	PHP 4-B54TB
5,2	5,6	5,95	A-1	2517	3/4	2 1/2	2 1/2	1 1/2	1 3/4	-	10,0	PHP 3-B56TB	A-1	2517	3/4	2 1/2	3 1/4	1 1/2	1 3/4	-	10,0	PHP 4-B56TB
5,4	5,8	6,15	A-1	2517	3/4	2 1/2	2 1/2	3/4	1 3/4	-	10,5	PHP 3-B58TB	A-1	2517	3/4	2 1/2	3 1/4	1 1/2	1 3/4	-	12,0	PHP 4-B58TB
5,6	6,0	6,35	A-1	2517	3/4	2 1/2	2 1/2	3/4	1 3/4	-	11,0	PHP 3-B60TB	A-1	2517	3/4	2 1/2	3 1/4	1 1/2	1 3/4	-	12,5	PHP 4-B60TB
5,8	6,2	6,55	A-1	2517	3/4	2 1/2	2 1/2	3/4	1 3/4	-	11,5	PHP 3-B62TB	A-1	2517	3/4	2 1/2	3 1/4	1 1/2	1 3/4	-	13,0	PHP 4-B62TB
6,0	6,4	6,75	A-1	2517	3/4	2 1/2	2 1/2	3/4	1 3/4	-	12,0	PHP 3-B64TB	A-1	2517	3/4	2 1/2	3 1/4	1 1/2	1 3/4	-	14,0	PHP 4-B64TB
6,2	6,6	6,95	A-1	2517	3/4	2 1/2	2 1/2	3/4	1 3/4	-	12,3	PHP 3-B66TB	A-1	2517	3/4	2 1/2	3 1/4	1 1/2	1 3/4	-	15,0	PHP 4-B66TB
6,4	6,8	7,15	A-1	2517	3/4	2 1/2	2 1/2	3/4	1 3/4	-	12,8	PHP 3-B68TB	A-1	2517	3/4	2 1/2	3 1/4	1 1/2	1 3/4	-	16,0	PHP 4-B68TB
7,0	7,4	7,75	A-1	2517	3/4	2 1/2	2 1/2	3/4	1 3/4	-	16,0	PHP 3-B74TB	A-1	2517	3/4	2 1/2	3 1/4	1 1/2	1 3/4	-	20,0	PHP 4-B74TB
8,2	8,6	8,95	A-2	2517	3/4	2 1/2	2 1/2	3/4	1 3/4	-	19,0	PHP 3-B86TB	A-2	2517	3/4	2 1/2	3 1/4	1 1/2	1 3/4	-	21,0	PHP 4-B86TB
9,0	9,4	9,75	A-2	2517	3/4	2 1/2	2 1/2	3/4	1 3/4	-	21,0	PHP 3-B94TB	A-2	2517	3/4	2 1/2	3 1/4	1 1/2	1 3/4	-	23,0	PHP 4-B94TB
10,6	11,0	11,35	A-2	2517	3/4	2 1/2	2 1/2	3/4	1 3/4	-	24,0	PHP 3-B110TB	A-2	2517	3/4	2 1/2	3 1/4	1 1/2	1 3/4	-	28,0	PHP 4-B110TB
12,0	12,4	12,75	A-3	2517	3/4	2 1/2	2 1/2	-	1 3/4	3/4	28,0	PHP 3-B124TB	A-3	2517	3/4	2 1/2	3 1/4	3/8	1 3/4	1 1/8	34,0	PHP 4-B124TB
15,0	15,4	15,75	A-3	2517	3/4	2 1/2	2 1/2	-	1 3/4	3/4	30,0	PHP 3-B154TB	A-3	2517	3/4	2 1/2	3 1/4	3/8	1 3/4	1 1/8	42,0	PHP 4-B154TB
18,0	18,4	18,75	A-3	2517	3/4	2 1/2	2 1/2	-	1 3/4	3/4	44,0	PHP 3-B184TB	A-3	2517	3/4	2 1/2	3 1/4	1/2	1 3/4	1	53,0	PHP 4-B184TB
19,6	20,0	20,35	A-3	3020	1 1/4	3	2 1/2	-	2	1/2	58,0	PHP 3-B200TB	A-3	3020	1 1/4	3	3 3/4	1/2	2	3/4	63,0	PHP 4-B200TB
24,6	25,0	25,35	A-3	3020	1 1/4	3	2 1/2	-	2	1/2	74,0	PHP 3-B250TB	A-3	3030	1 1/4	3	3 3/4	-	3	1 1/4	80,0	PHP 4-B250TB
29,6	30,0	30,35	A-3	3020	1 1/4	3	2 1/2	-	2	1/2	84,0	PHP 3-B300TB	A-3	3030	1 1/4	3	3 3/4	-	3	1 1/4	100,0	PHP 4-B300TB
37,6	38,0	38,35	B-3	3020	1 1/4	3	2 1/2	-	3	1/2	135,0	PHP 3-B380TB	A-3	3030	1 1/4	3	3 3/4	-	3	1 1/4	142,0	PHP 4-B380TB



Classical V-belt pulleys

A/B taper bushed

- ▶ Belts
- ▶ Chains
- ▶ Couplings
- ▶ Bushings and Hubs
- ▶ Sprockets
- ▶ Pulleys
- ▶ Smart tools

Type A-1

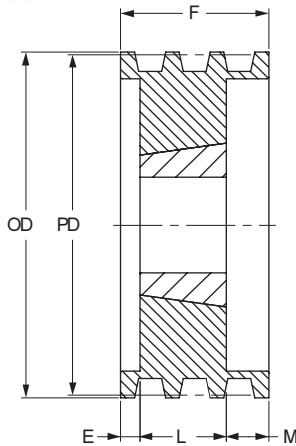

Type A-2

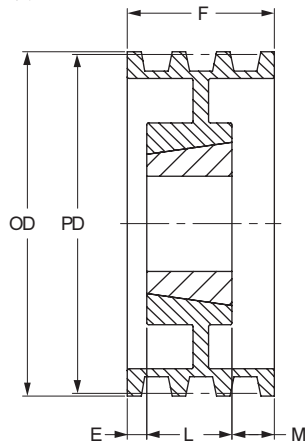

Type A-3

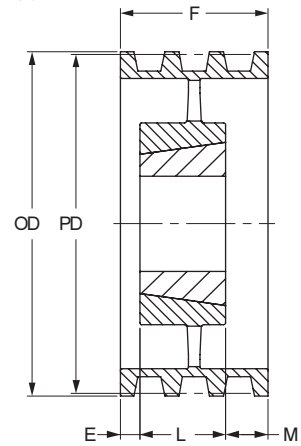

5 Groove

6 Groove

Pitch Diameter		Outside Diameter	Type	Bush	Bore		F	E	L	M	Weight	Designation	Type	Bush	Bore		F	E	L	M	Weight	Designation	
A Belt	B Belt				Min	Max									Min	Max							
Inch	Inch	Inch			Inch	Inch	Inch	Inch	Inch	Inch	lbs				Inch	Inch	Inch	Inch	Inch	Inch	lbs		
3,0	3,4	3,75	A-1	1210	5/8	1 1/4	4	2 1/2	1 1/2	-	5,0	PHP 5-B34TB	-	-	-	-	-	-	-	-	-	-	-
3,2	3,6	3,95	A-1	1210	5/8	1 1/4	4	2 1/2	1 1/2	-	5,5	PHP 5-B36TB	-	-	-	-	-	-	-	-	-	-	-
3,4	3,8	4,15	A-1	1215	5/8	1 5/8	4	2 1/2	1 1/2	-	6,0	PHP 5-B38TB	-	-	-	-	-	-	-	-	-	-	-
3,6	4,0	4,35	A-1	1215	5/8	1 5/8	4	2 1/2	1 1/2	-	6,5	PHP 5-B40TB	-	-	-	-	-	-	-	-	-	-	-
3,8	4,2	4,55	A-1	1615	1/2	1 5/8	4	2 1/2	1 1/2	-	7,0	PHP 5-B42TB	A-1	1615	1/2	1 5/8	4 3/4	3 3/4	1 1/2	-	8,0	PHP 6-B42TB	
4,0	4,4	4,75	A-1	1615	1/2	1 5/8	4	2 1/2	1 1/2	-	8,0	PHP 5-B44TB	A-1	1615	1/2	1 5/8	4 3/4	3 3/4	1 1/2	-	9,0	PHP 6-B44TB	
4,2	4,6	4,95	A-1	1615	1/2	1 5/8	4	2 1/2	1 1/2	-	9,0	PHP 5-B46TB	A-1	1615	1/2	1 5/8	4 3/4	3 3/4	1 1/2	-	10,0	PHP 6-B46TB	
4,6	5,0	5,35	A-1	1615	1/2	1 5/8	4	7/8	1 1/2	-	10,5	PHP 5-B50TB	A-1	1615	1/2	1 5/8	4 3/4	1 1/4	1 1/2	2	11,9	PHP 6-B50TB	
4,8	5,2	5,55	A-1	1615	1/2	1 5/8	4	7/8	1 1/2	-	11,3	PHP 5-B52TB	A-1	1615	1/2	1 5/8	4 3/4	1 1/4	1 1/2	2	12,8	PHP 6-B52TB	
5,0	5,4	5,75	A-1	2517	3/4	2 1/2	4	2 3/4	1 3/4	-	11,5	PHP 5-B54TB	A-1	1615	1/2	1 5/8	4 3/4	1 1/4	1 1/2	2	13,7	PHP 6-B54TB	
5,2	5,6	5,95	A-1	2517	3/4	2 1/2	4	2 3/4	1 3/4	-	12,0	PHP 5-B56TB	A-1	1615	1/2	1 5/8	4 3/4	1 1/4	1 1/2	2	14,6	PHP 6-B56TB	
5,6	6,0	6,35	A-1	2517	3/4	2 1/2	4	2 3/4	1 3/4	-	14,0	PHP 5-B60TB	A-1	2517	3/4	2 1/2	4 3/4	3	1 3/4	-	16,0	PHP 6-B60TB	
6,0	6,4	6,75	A-1	2517	3/4	2 1/2	4	2 3/4	1 3/4	-	16,0	PHP 5-B64TB	A-1	2517	3/4	2 1/2	4 3/4	3	1 3/4	-	19,5	PHP 6-B64TB	
6,4	6,8	7,15	A-1	2517	3/4	2 1/2	4	2 3/4	1 3/4	-	18,0	PHP 5-B68TB	A-1	2517	3/4	2 1/2	4 3/4	3	1 3/4	-	21,0	PHP 6-B68TB	
7,0	7,4	7,75	A-1	2517	3/4	2 1/2	4	2 3/4	1 3/4	-	22,0	PHP 5-B74TB	A-1	2517	3/4	2 1/2	4 3/4	3	1 3/4	-	25,0	PHP 6-B74TB	
8,2	8,6	8,95	A-2	2517	3/4	2 1/2	4	2 3/4	1 3/4	-	24,0	PHP 5-B86TB	A-2	2517	3/4	2 1/2	4 3/4	3	1 3/4	-	27,0	PHP 6-B86TB	
9,0	9,4	9,75	A-2	2517	3/4	2 1/2	4	2 3/4	1 3/4	-	26,0	PHP 5-B94TB	A-2	2517	3/4	2 1/2	4 3/4	3	1 3/4	-	28,0	PHP 6-B94TB	
10,6	11,0	11,35	A-2	2517	3/4	2 1/2	4	2 3/4	1 3/4	-	35,0	PHP 5-B110TB	A-2	2517	3/4	2 1/2	4 3/4	3	1 3/4	-	34,0	PHP 6-B110TB	
12,0	12,4	12,75	A-3	2517	3/4	2 1/2	4	3/4	1 3/4	1 1/2	40,0	PHP 5-B124TB	A-3	2517	3/4	2 1/2	4 3/4	1 1/8	1 3/4	1 1/8	43,0	PHP 6-B124TB	
15,0	15,4	15,75	A-3	2517	3/4	2 1/2	4	3/4	1 3/4	1 1/2	47,0	PHP 5-B154TB	A-3	2517	3/4	2 1/2	4 3/4	1 1/2	1 3/4	1 1/2	52,0	PHP 6-B154TB	
18,0	18,4	18,75	A-3	2517	3/4	2 1/2	4	3/4	1 3/4	1 1/2	52,0	PHP 5-B184TB	A-3	2517	3/4	2 1/2	4 3/4	1 1/2	1 3/4	1 1/2	62,0	PHP 6-B184TB	
19,6	20,0	20,35	A-3	3030	1 1/4	3	4	1 1/4	3	3/4	75,0	PHP 5-B200TB	A-3	3030	1 1/4	3	4 3/4	1 1/2	3	1 1/4	85,0	PHP 6-B200TB	
24,6	25,0	25,35	A-3	3030	1 1/4	3	4	1 1/4	3	3/4	81,0	PHP 5-B250TB	A-3	3030	1 1/4	3	4 3/4	1 1/2	3	1 1/4	100,0	PHP 6-B250TB	
29,6	30,0	30,35	A-3	3030	1 1/4	3	4	1 1/4	3	3/4	109,0	PHP 5-B300TB	A-3	3030	1 1/4	3	4 3/4	1 1/2	3	1 1/4	137,0	PHP 6-B300TB	
37,6	38,0	38,35	A-3	3030	1 1/4	3	4	1 1/4	3	3/4	158,0	PHP 5-B380TB	A-3	3030	1 1/4	3	4 3/4	1 1/2	3	1 1/4	168,0	PHP 6-B380TB	

8 Groove

10 Groove

Pitch Diameter		Outside Diameter	Type	Bush	Bore		F	E	L	M	Weight	Designation	Type	Bush	Bore		F	E	L	M	Weight	Designation
A Belt	B Belt				Min	Max									Min	Max						
Inch	Inch	Inch			Inch	Inch	Inch	Inch	Inch	Inch	lbs				Inch	Inch	Inch	Inch	Inch	Inch	lbs	
5,0	5,4	5,75	A-1	2517	3/4	2 1/2	6 1/4	1 7/8	1 3/4	2 5/8	16,0	PHP 8-B54TB	A-1	2517	3/4	2 1/2	7 3/4	3	1 3/4	3	18,0	PHP 10-B54TB
5,2	5,6	5,95	A-1	2517	3/4	2 1/2	6 1/4	1 7/8	1 3/4	2 5/8	17,0	PHP 8-B56TB	A-1	2517	3/4	2 1/2	7 3/4	3	1 3/4	3	20,0	PHP 10-B56TB
5,6	6,0	6,35	A-1	2517	3/4	2 1/2	6 1/4	1 7/8	1 3/4	2 5/8	19,0	PHP 8-B60TB	A-1	2517	3/4	2 1/2	7 3/4	3	1 3/4	3	22,0	PHP 10-B60TB
6,0	6,4	6,75	A-1	2517	3/4	2 1/2	6 1/4	1 7/8	1 3/4	2 5/8	21,0	PHP 8-B64TB	A-1	2517	3/4	2 1/2	7 3/4	3	1 3/4	3	25,5	PHP 10-B64TB
6,4	6,8	7,15	A-1	2517	3/4	2 1/2	6 1/4	1 7/8	1 3/4	2 5/8	25,0	PHP 8-B68TB	A-1	2517	3/4	2 1/2	7 3/4	3	1 3/4	3	28,0	PHP 10-B68TB
7,0	7,4	7,75	A-1	2517	3/4	2 1/2	6 1/4	1 7/8	1 3/4	2 5/8	29,0	PHP 8-B74TB	A-1	2517	3/4	2 1/2	7 3/4	3	1 3/4	3	35,0	PHP 10-B74TB
8,2	8,6	8,95	A-1	3030	1 1/4	3	6 1/4	1	3	2 1/4	37,0	PHP 8-B86TB	A-1	3030	1 1/4	3	7 3/4	2	3	2 3/4	43,0	PHP 10-B86TB
9,0	9,4	9,75	A-2	3030	1 1/4	3	6 1/4	1	3	2 1/4	41,0	PHP 8-B94TB	A-2	3030	1 1/4	3	7 3/4	2	3	2 3/4	46,0	PHP 10-B94TB
10,6	11,0	11,35	A-2	3030	1 1/4	3	6 1/4	1	3	2 1/4	51,0	PHP 8-B110TB	A-2	3030	1 1/4	3	7 3/4	2	3	2 3/4	52,0	PHP 10-B110TB
12,0	12,4	12,75	A-3	3030	1 1/4	3	6 1/4	1	3	2 1/4	56,0	PHP 8-B124TB	-	-	-	-	-	-	-	-	-	-
15,0	15,4	15,75	A-3	3030	1 1/4	3	6 1/4	1	3	2 1/4	69,0	PHP 8-B154TB	-	-	-	-	-	-	-	-	-	-
18,0	18,4	18,75	A-3	3030	1 1/4	3	6 1/4	1	3	2 1/4	99,0	PHP 8-B184TB	-	-	-	-	-	-	-	-	-	-
19,6	20,0	20,35	A-3	3030	1 1/4	3	6 1/4	1	3	2 1/4	115,0	PHP 8-B200TB	-	-	-	-	-	-	-	-	-	-
24,6	25,0	25,35	A-3	3535	2	3 1/2	6 1/4	3/4	3 1/2	2	145,0	PHP 8-B250TB	-	-	-	-	-	-	-	-	-	-
29,6	30,0	30,35	A-3	3535	2	3 1/2	6 1/4	3/4	3 1/2	2	170,0	PHP 8-B300TB	-	-	-	-	-	-	-	-	-	-
37,6	38,0	38,35	A-3	4040	1 3/4	4	6 1/4	1 1/8	4	1 1/8	260,0	PHP 8-B380TB	-	-	-	-	-	-	-	-	-	-



Classical V-belt pulleys

C taper bushed



Type A-1

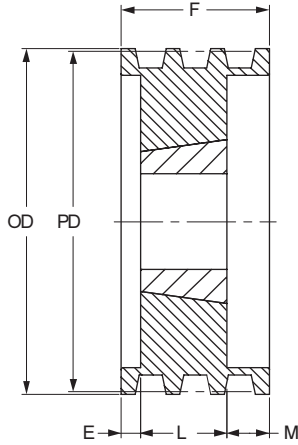

Type A-2

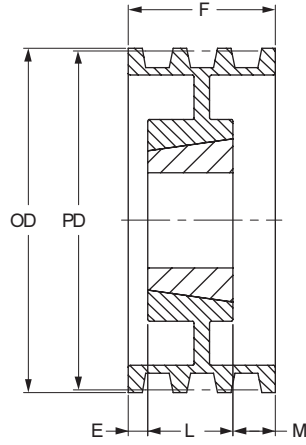

Type A-3

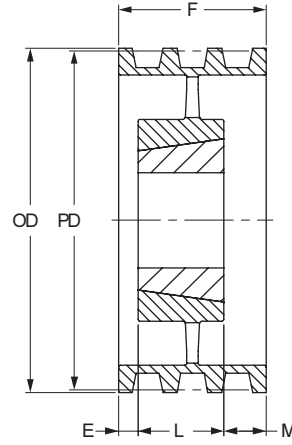

Type B-3

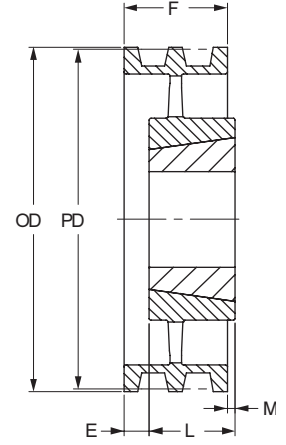

2 Groove

3 Groove

Pitch Diameter	Outside Diameter	Type	Bush	Bore		F	E	L	M	Weight	Designation	Type	Bush	Bore		F	E	L	M	Weight	Designation
				Min	Max									Min	Max						
Inch	Inch			Inch	Inch	Inch	Inch	Inch	Inch	lbs				Inch	Inch	Inch	Inch	Inch	Inch	lbs	
7,0	7,4	A-1	2517	3/4	2 1/2	2 3/8	5/8	1 3/4	0	15	PHP 2-C70TB	A-1	2517	3/4	2 1/2	3 3/8	1/4	1 3/4	1 3/8	18	PHP 3-C70TB
7,5	7,9	A-1	2517	3/4	2 1/2	2 3/8	5/8	1 3/4	0	17	PHP 2-C75TB	A-1	2517	3/4	2 1/2	3 3/8	1/4	1 3/4	1 3/8	20	PHP 3-C75TB
8,0	8,4	A-1	2517	3/4	2 1/2	2 3/8	5/8	1 3/4	0	20	PHP 2-C80TB	A-1	2517	3/4	2 1/2	3 3/8	1/4	1 3/4	1 3/8	22	PHP 3-C80TB
8,5	8,9	A-2	2517	3/4	2 1/2	2 3/8	5/8	1 3/4	0	22	PHP 2-C85TB	A-2	2517	3/4	2 1/2	3 3/8	1/4	1 3/4	1 3/8	23	PHP 3-C85TB
9,0	9,4	A-2	2517	3/4	2 1/2	2 3/8	5/8	1 3/4	0	23	PHP 2-C90TB	A-2	2517	3/4	2 1/2	3 3/8	1/4	1 3/4	1 3/8	24	PHP 3-C90TB
9,5	9,9	A-2	2517	3/4	2 1/2	2 3/8	5/8	1 3/4	0	24	PHP 2-C95TB	A-2	2517	3/4	2 1/2	3 3/8	1/4	1 3/4	1 3/8	27	PHP 3-C95TB
10,0	10,4	A-2	2517	3/4	2 1/2	2 3/8	5/8	1 3/4	0	25	PHP 2-C100TB	A-2	2517	3/4	2 1/2	3 3/8	1/4	1 3/4	1 3/8	29	PHP 3-C100TB
10,5	10,9	A-2	2517	3/4	2 1/2	2 3/8	5/8	1 3/4	0	26	PHP 2-C105TB	A-2	2517	3/4	2 1/2	3 3/8	1/4	1 3/4	1 3/8	32	PHP 3-C105TB
11,0	11,4	A-2	2517	3/4	2 1/2	2 3/8	5/8	1 3/4	0	27	PHP 2-C110TB	A-2	2517	3/4	2 1/2	3 3/8	1/4	1 3/4	1 3/8	35	PHP 3-C110TB
12,0	12,4	A-2	2517	3/4	2 1/2	2 3/8	5/8	1 3/4	0	33	PHP 2-C120TB	A-2	3020	1 1/4	3	3 3/8	0	2	1 3/8	44	PHP 3-C120TB
13,0	13,4	A-3	2517	3/4	2 1/2	2 3/8	5/8	1 3/4	0	35	PHP 2-C130TB	A-3	3020	1 1/4	3	3 3/8	0	2	1 3/8	49	PHP 3-C130TB
14,0	14,4	A-3	2517	3/4	2 1/2	2 3/8	5/8	1 3/4	0	36	PHP 2-C140TB	A-3	3020	1 1/4	3	3 3/8	0	2	1 3/8	50	PHP 3-C140TB
16,0	16,4	A-3	2517	3/4	2 1/2	2 3/8	5/8	1 3/4	0	42	PHP 2-C160TB	A-3	3020	1 1/4	3	3 3/8	0	2	1 3/8	64	PHP 3-C160TB
18,0	18,4	A-3	3020	1 1/4	3	2 3/8	0	2	3/8	42	PHP 2-C180TB	A-3	3030	1 1/4	3	3 3/8	0	3	3/8	64	PHP 3-C180TB
20,0	20,4	A-3	3020	1 1/4	3	2 3/8	0	2	3/8	45	PHP 2-C200TB	A-3	3030	1 1/4	3	3 3/8	0	3	3/8	78	PHP 3-C200TB
24,0	24,4	A-3	3020	1 1/4	3	2 3/8	0	2	3/8	72	PHP 2-C240TB	A-3	3030	1 1/4	3	3 3/8	0	3	3/8	96	PHP 3-C240TB
30,0	30,4	-	-	-	-	-	-	-	-	-	-	B-3	3535	2	3 1/2	3 3/8	0	3 1/2	1/8	125	PHP 3-C300TB
36,0	36,4	-	-	-	-	-	-	-	-	-	-	B-3	3535	2	3 1/2	3 3/8	0	3 1/2	1/8	175	PHP 3-C360TB



Classical V-belt pulleys

C taper bushed

- ▶ Belts
- ▶ Chains
- ▶ Couplings
- ▶ Bushings and Hubs
- ▶ Sprockets
- ▶ Pulleys
- ▶ Smart tools

Type A-1

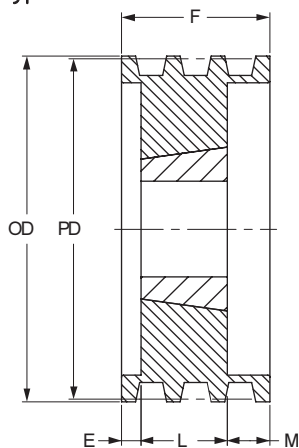

Type A-2

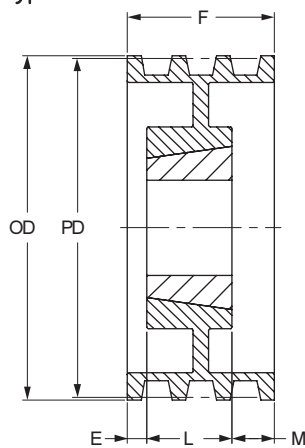

Type A-3

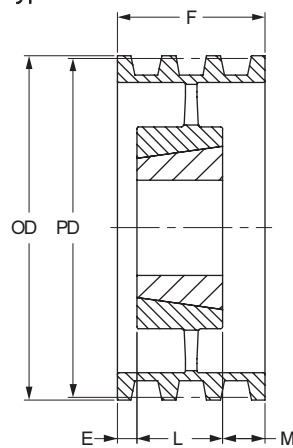

4 Groove

5 Groove

Pitch Diameter	Outside Diameter	Type	Bush	Bore		F	E	L	M	Weight	Designation	Type	Bush	Bore		F	E	L	M	Weight	Designation
				Min	Max									Min	Max						
C Belt				Inch	Inch	Inch	Inch	Inch	Inch	lbs				Inch	Inch	Inch	Inch	Inch	Inch	lbs	
7,0	7,4	A-1	2517	3/4	2 1/2	4 3/8	1/2	1 3/4	2 1/8	20	PHP 4-C70TB	A-1	2517	3/4	2 1/2	5 3/8	1 1/2	1 3/4	2 1/8	23	PHP 5-C70TB
7,5	7,9	A-1	2517	3/4	2 1/2	4 3/8	1/2	1 3/4	2 1/8	23	PHP 4-C75TB	A-1	2517	3/4	2 1/2	5 3/8	1 1/2	1 3/4	2 1/8	26	PHP 5-C75TB
8,0	8,4	A-1	2517	3/4	2 1/2	4 3/8	1/2	1 3/4	2 1/8	25	PHP 4-C80TB	A-1	2517	3/4	2 1/2	5 3/8	1 1/2	1 3/4	2 1/8	30	PHP 5-C80TB
8,5	8,9	A-2	2517	3/4	2 1/2	4 3/8	1/2	1 3/4	2 1/8	26	PHP 4-C85TB	A-1	2517	3/4	2 1/2	5 3/8	1 1/2	1 3/4	2 1/8	34	PHP 5-C85TB
9,0	9,4	A-2	2517	3/4	2 1/2	4 3/8	1/2	1 3/4	2 1/8	27	PHP 4-C90TB	A-2	2517	3/4	2 1/2	5 3/8	1 1/2	1 3/4	2 1/8	35	PHP 5-C90TB
9,5	9,9	A-2	2517	3/4	2 1/2	4 3/8	1/2	1 3/4	2 1/8	36	PHP 4-C95TB	A-2	2517	3/4	2 1/2	5 3/8	1 1/2	1 3/4	2 1/8	36	PHP 5-C95TB
10,0	10,4	A-2	2517	3/4	2 1/2	4 3/8	1/2	1 3/4	2 1/8	39	PHP 4-C100TB	A-2	2517	3/4	2 1/2	5 3/8	1 1/2	1 3/4	2 1/8	39	PHP 5-C100TB
10,5	10,9	A-2	2517	3/4	2 1/2	4 3/8	1/2	1 3/4	2 1/8	42	PHP 4-C105TB	A-2	2517	3/4	2 1/2	5 3/8	1 1/2	1 3/4	2 1/8	42	PHP 5-C105TB
11,0	11,4	A-2	2517	3/4	2 1/2	4 3/8	1/2	1 3/4	2 1/8	45	PHP 4-C110TB	A-2	2517	3/4	2 1/2	5 3/8	1 1/2	1 3/4	2 1/8	43	PHP 5-C110TB
12,0	12,4	A-2	2517	3/4	3	4 3/8	0	3	1 3/8	47	PHP 4-C120TB	A-2	3030	1 1/4	3	5 3/8	1/2	3	1 7/8	58	PHP 5-C120TB
13,0	13,4	A-3	3030	1 1/4	3	4 3/8	0	3	1 3/8	51	PHP 4-C130TB	A-3	3030	1 1/4	3	5 3/8	1/2	3	1 7/8	63	PHP 5-C130TB
14,0	14,4	A-3	3030	1 1/4	3	4 3/8	0	3	1 3/8	54	PHP 4-C140TB	A-3	3030	1 1/4	3	5 3/8	1/2	3	1 7/8	65	PHP 5-C140TB
16,0	16,4	A-3	3030	1 1/4	3	4 3/8	0	3	1 3/8	71	PHP 4-C160TB	A-3	3030	1 1/4	3	5 3/8	1/2	3	1 7/8	70	PHP 5-C160TB
18,0	18,4	A-3	3030	1 1/4	3	4 3/8	0	3	1 3/8	81	PHP 4-C180TB	A-3	3030	1 1/4	3	5 3/8	1/2	3	1 7/8	83	PHP 5-C180TB
20,0	20,4	A-3	3030	1 1/4	3	4 3/8	0	3	1 3/8	84	PHP 4-C200TB	A-3	3535	2	3 1/2	5 3/8	0	3 1/2	1 7/8	110	PHP 5-C200TB
24,0	24,4	A-3	3030	1 1/4	3	4 3/8	0	3	1 3/8	116	PHP 4-C240TB	A-3	3535	2	3 1/2	5 3/8	0	3 1/2	1 7/8	138	PHP 5-C240TB
30,0	30,4	A-3	3535	2	3 1/2	4 3/8	0	3 1/2	7/8	164	PHP 4-C300TB	A-3	3535	2	3 1/2	5 3/8	0	3 1/2	1 7/8	176	PHP 5-C300TB
36,0	36,4	A-3	3535	2	3 1/2	4 3/8	0	3 1/2	7/8	192	PHP 4-C360TB	A-3	4040	1 3/4	4	5 3/8	1/4	4	1 1/8	244	PHP 5-C360TB
44,0	44,4	A-3	4040	1 3/4	4	4 3/8	0	4	3/8	282	PHP 4-C440TB	A-3	4040	1 3/4	4	5 3/8	1/4	4	1 1/8	288	PHP 5-C440TB



Classical V-belt pulleys

C taper bushed



Type A-1

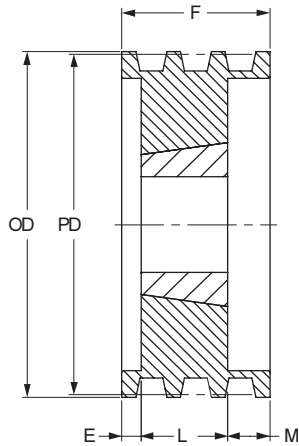

Type A-2

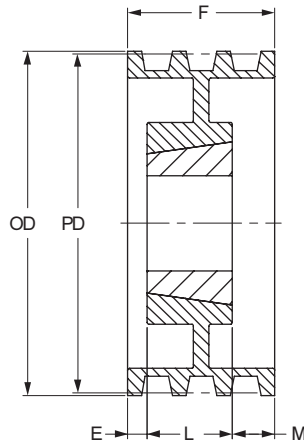

Type A-3

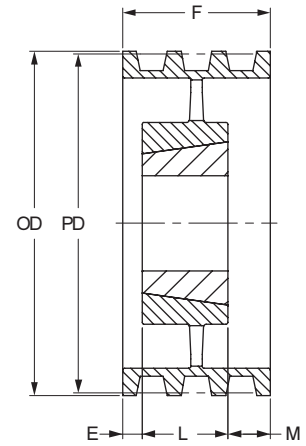

6 Groove

8 Groove

Pitch Diameter	Outside Diameter	Type	Bush	Bore		F	E	L	M	Weight	Designation	Type	Bush	Bore		F	E	L	M	Weight	Designation	
				Min	Max									Min	Max							
Inch	Inch			Inch	Inch	Inch	Inch	Inch	Inch	lbs				Inch	Inch	Inch	Inch	Inch	Inch	lbs		
7,0	7,4	A-1	3030	1 1/4	3	6 3/8	1	3	2 3/8	30	PHP 6-C70TB	-	-	-	-	-	-	-	-	-	-	-
7,5	7,9	A-1	3030	1 1/4	3	6 3/8	1	3	2 3/8	31	PHP 6-C75TB	-	-	-	-	-	-	-	-	-	-	-
8,0	8,4	A-1	3030	1 1/4	3	6 3/8	1	3	2 3/8	35	PHP 6-C80TB	A-1	3030	1 1/4	3	8 3/8	2	3	3 3/8	45	PHP 8-C80TB	PHP 8-C85TB
8,5	8,9	A-1	3030	1 1/4	3	6 3/8	1	3	2 3/8	40	PHP 6-C85TB	A-1	3030	1 1/4	3	8 3/8	2	3	3 3/8	47	PHP 8-C85TB	PHP 8-C90TB
9,0	9,4	A-1	3030	1 1/4	3	6 3/8	1	3	2 3/8	47	PHP 6-C90TB	A-1	3535	2	3 1/2	8 3/8	1 1/2	3 1/2	3 3/8	64	PHP 8-C90TB	PHP 8-C95TB
9,5	9,9	A-1	3030	1 1/4	3	6 3/8	1	3	2 3/8	53	PHP 6-C95TB	A-1	3535	2	3 1/2	8 3/8	1 1/2	3 1/2	3 3/8	67	PHP 8-C95TB	PHP 8-C100TB
10,0	10,4	A-1	3030	1 1/4	3	6 3/8	1	3	2 3/8	57	PHP 6-C100TB	A-1	3535	2	3 1/2	8 3/8	1 1/2	3 1/2	3 3/8	70	PHP 8-C100TB	PHP 8-C105TB
10,5	10,9	A-2	3030	1 1/4	3	6 3/8	1	3	2 3/8	58	PHP 6-C105TB	A-1	3535	2	3 1/2	8 3/8	1 1/2	3 1/2	3 3/8	84	PHP 8-C105TB	PHP 8-C110TB
11,0	11,4	A-2	3030	1 1/4	3	6 3/8	1	3	2 3/8	66	PHP 6-C110TB	A-1	3535	2	3 1/2	8 3/8	1 1/2	3 1/2	3 3/8	87	PHP 8-C110TB	PHP 8-C120TB
12,0	12,4	A-2	3030	1 1/4	3	6 3/8	1	3	2 3/8	70	PHP 6-C120TB	A-2	3535	2	3 1/2	8 3/8	1 1/2	3 1/2	3 3/8	90	PHP 8-C120TB	PHP 8-C130TB
13,0	13,4	A-3	3030	1 1/4	3	6 3/8	1	3	2 3/8	75	PHP 6-C130TB	A-2	3535	2	3 1/2	8 3/8	1 1/2	3 1/2	3 3/8	97	PHP 8-C130TB	PHP 8-C140TB
14,0	14,4	A-3	3535	2	3 1/2	6 3/8	1 1/2	3 1/2	2 3/8	80	PHP 6-C140TB	A-2	3535	2	3 1/2	8 3/8	1 1/2	3 1/2	3 3/8	105	PHP 8-C140TB	PHP 8-C150TB
16,0	16,4	A-3	3535	2	3 1/2	6 3/8	1 1/2	3 1/2	2 3/8	87	PHP 6-C160TB	A-3	3535	2	3 1/2	8 3/8	1 1/2	3 1/2	3 3/8	115	PHP 8-C160TB	PHP 8-C180TB
18,0	18,4	A-3	3535	2	3 1/2	6 3/8	1 1/2	3 1/2	2 3/8	102	PHP 6-C180TB	A-3	4040	1 3/4	4	8 3/8	1 1/2	4	2 7/8	137	PHP 8-C180TB	PHP 8-C200TB
20,0	20,4	A-3	3535	2	3 1/2	6 3/8	1 1/2	3 1/2	2 3/8	126	PHP 6-C200TB	A-3	4040	1 3/4	4	8 3/8	1 1/2	4	2 7/8	180	PHP 8-C200TB	PHP 8-C240TB
24,0	24,4	A-3	3535	2	3 1/2	6 3/8	1 1/2	3 1/2	2 3/8	150	PHP 6-C240TB	A-3	4040	1 3/4	4	8 3/8	1 1/2	4	2 7/8	205	PHP 8-C240TB	PHP 8-C300TB
30,0	30,4	A-3	4040	1 3/4	4	6 3/8	1	4	1 3/8	226	PHP 6-C300TB	A-3	4040	1 3/4	4	8 3/8	1 1/2	4	2 7/8	263	PHP 8-C300TB	PHP 8-C360TB
36,0	36,4	A-3	4040	1 3/4	4	6 3/8	1	4	1 3/8	270	PHP 6-C360TB	A-3	4545	2 1/4	4 1/2	8 3/8	1 1/4	4 1/2	2 5/8	343	PHP 8-C360TB	PHP 8-C440TB
44,0	44,4	A-3	4040	1 3/4	4	6 3/8	1	4	1 3/8	320	PHP 6-C440TB	A-3	4545	2 1/4	4 1/2	8 3/8	1 1/4	4 1/2	2 5/8	432	PHP 8-C440TB	

10 Groove

12 Groove

Pitch Diameter	Outside Diameter	Type	Bush	Bore		F	E	L	M	Weight	Designation	Type	Bush	Bore		F	E	L	M	Weight	Designation	
				Min	Max									Min	Max							
Inch	Inch			Inch	Inch	Inch	Inch	Inch	Inch	lbs				Inch	Inch	Inch	Inch	Inch	Inch	lbs		
9,0	9,4	A-1	4545	2 1/4	4 1/2	10 3/8	1 1/2	4 1/2	4 3/8	57	PHP 10-C90TB	A-1	4040	1 3/4	4	12 3/8	3 1/2	4	4 7/8	65	PHP 12-C90TB	PHP 12-C95TB
9,5	9,9	A-1	4545	2 1/4	4 1/2	10 3/8	1 1/2	4 1/2	4 3/8	66	PHP 10-C95TB	A-1	4040	1 3/4	4	12 3/8	3 1/2	4	4 7/8	75	PHP 12-C95TB	PHP 12-C100TB
10,0	10,4	A-1	4545	2 1/4	4 1/2	10 3/8	1 1/2	4 1/2	4 3/8	77	PHP 10-C100TB	A-1	4040	1 3/4	4	12 3/8	3 1/2	4	4 7/8	85	PHP 12-C100TB	PHP 12-C105TB
10,5	10,9	A-1	4545	2 1/4	4 1/2	10 3/8	1 1/2	4 1/2	4 3/8	87	PHP 10-C105TB	A-1	4040	1 3/4	4	12 3/8	3 1/2	4	4 7/8	95	PHP 12-C105TB	PHP 12-C110TB
11,0	11,4	A-1	4545	2 1/4	4 1/2	10 3/8	1 1/2	4 1/2	4 3/8	98	PHP 10-C110TB	A-1	4040	1 3/4	4	12 3/8	3 1/2	4	4 7/8	104	PHP 12-C110TB	PHP 12-C120TB
12,0	12,4	A-1	4545	2 1/4	4 1/2	10 3/8	1 1/2	4 1/2	4 3/8	121	PHP 10-C120TB	A-1	4040	1 3/4	4	12 3/8	3 1/2	4	4 7/8	126	PHP 12-C120TB	PHP 12-C130TB
13,0	13,4	A-1	4545	2 1/4	4 1/2	10 3/8	2	4 1/2	3 7/8	146	PHP 10-C130TB	A-1	4545	2 1/4	4 1/2	12 3/8	3	4 1/2	4 7/8	156	PHP 12-C130TB	PHP 12-C140TB
14,0	14,4	A-2	4545	2 1/4	4 1/2	10 3/8	2	4 1/2	3 7/8	173	PHP 10-C140TB	A-1	4545	2 1/4	4 1/2	12 3/8	3	4 1/2	4 7/8	184	PHP 12-C140TB	
16,0	16,4	A-2	4545	2 1/4	4 1/2	10 3/8	2	4 1/2	3 7/8	233	PHP 10-C160TB	-	-	-	-	-	-	-	-	-	-	
18,0	18,4	A-2	4545	2 1/4	4 1/2	10 3/8	2	4 1/2	3 7/8	176	PHP 10-C180TB	-	-	-	-	-	-	-	-	-	-	
20,0	20,4	A-3	4545	2 1/4	4 1/2	10 3/8	2	4 1/2	3 7/8	201	PHP 10-C200TB	-	-	-	-	-	-	-	-	-	-	
24,0	24,4	A-3	4545	2 1/4	4 1/2	10 3/8	2	4 1/2	3 7/8	243	PHP 10-C240TB	-	-	-	-	-	-	-	-	-	-	
30,0	30,4	A-3	4545	2 1/4	4 1/2	10 3/8	2	4 1/2	3 7/8	320	PHP 10-C300TB	-	-	-	-	-	-	-	-	-	-	
36,0	36,4	A-3	4545	2 1/4	4 1/2	10 3/8	2	4 1/2	3 7/8	464	PHP 10-C360TB	-	-	-	-	-	-	-	-	-	-	
44,0	44,4	A-3	4545	2 1/4	4 1/2	10 3/8	2	4 1/2	3 7/8	508	PHP 10-C440TB	-	-	-	-	-	-	-	-	-	-	



Classical V-belt pulleys

D taper bushed

- ▶ Belts
- ▶ Chains
- ▶ Couplings
- ▶ Bushings and Hubs
- ▶ Sprockets
- ▶ Pulleys
- ▶ Smart tools

Type A-1

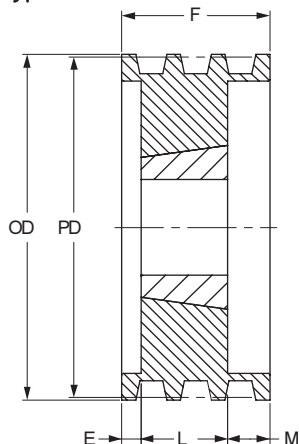

Type A-2

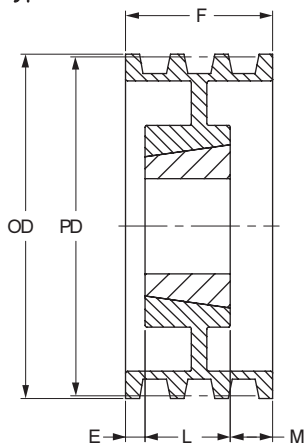

Type A-3

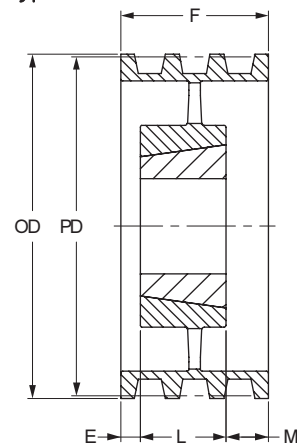

4 Groove

5 Groove

Pitch Diameter	Outside Diameter	Type	Bush	Bore		F	E	L	M	Weight	Designation	Type	Bush	Bore		F	E	L	M	Weight	Designation
				Min	Max									Min	Max						
Inch	Inch			Inch	Inch	Inch	Inch	Inch	Inch	lbs			Inch	Inch	Inch	Inch	Inch	Inch	Inch	lbs	
12,0	12,6	A-2	3535	2	3 1/2	6 1/16	3/4	3 1/2	1 13/16	63	PHP 4-D120TB	A-1	4040	1 3/4	4	7 1/2	1/4	4	2 3/4	82	PHP 5-D120TB
13,0	13,6	A-2	3535	2	3 1/2	6 1/16	3/4	3 1/2	1 13/16	73	PHP 4-D130TB	A-2	4040	1 3/4	4	7 1/2	3/4	4	2 3/4	87	PHP 5-D130TB
13,5	14,1	A-2	3535	2	3 1/2	6 1/16	3/4	3 1/2	1 13/16	78	PHP 4-D135TB	A-2	4040	1 3/4	4	7 1/2	3/4	4	2 3/4	92	PHP 5-D135TB
14,0	14,6	A-2	3535	2	3 1/2	6 1/16	3/4	3 1/2	1 13/16	83	PHP 4-D140TB	A-2	4040	1 3/4	4	7 1/2	3/4	4	2 3/4	97	PHP 5-D140TB
14,5	15,1	A-2	3535	2	3 1/2	6 1/16	3/4	3 1/2	1 13/16	94	PHP 4-D145TB	A-2	4040	1 3/4	4	7 1/2	3/4	4	2 3/4	102	PHP 5-D145TB
15,0	15,6	A-2	3535	2	3 1/2	6 1/16	3/4	3 1/2	1 13/16	94	PHP 4-D150TB	A-2	4040	1 3/4	4	7 1/2	3/4	4	2 3/4	107	PHP 5-D150TB
15,5	16,1	A-2	3535	2	3 1/2	6 1/16	3/4	3 1/2	1 13/16	99	PHP 4-D155TB	A-2	4040	1 3/4	4	7 1/2	3/4	4	2 3/4	112	PHP 5-D155TB
16,0	16,6	A-2	3535	2	3 1/2	6 1/16	3/4	3 1/2	1 13/16	104	PHP 4-D160TB	A-2	4040	1 3/4	4	7 1/2	3/4	4	2 3/4	112	PHP 5-D160TB
18,0	18,6	A-3	3535	2	3 1/2	6 1/16	3/4	3 1/2	1 13/16	109	PHP 4-D180TB	A-3	4040	1 3/4	4	7 1/2	1	4	2 1/2	132	PHP 5-D180TB
22,0	22,6	A-3	4040	1 3/4	4	6 1/16	3/4	4	1 7/16	142	PHP 4-D220TB	A-3	4040	1 3/4	4	7 1/2	1	4	2 1/2	162	PHP 5-D220TB
27,0	27,6	A-3	4040	1 3/4	4	6 1/16	3/4	4	1 7/16	182	PHP 4-D270TB	A-3	4040	1 3/4	4	7 1/2	1	4	2 1/2	207	PHP 5-D270TB

6 Groove

8 Groove

Pitch Diameter	Outside Diameter	Type	Bush	Bore		F	E	L	M	Weight	Designation	Type	Bush	Bore		F	E	L	M	Weight	Designation
				Min	Max									Min	Max						
Inch	Inch			Inch	Inch	Inch	Inch	Inch	Inch	lbs			Inch	Inch	Inch	Inch	Inch	Inch	Inch	lbs	
12,0	12,6	A-1	4040	1 3/4	4	8 15/16	1	4	3 15/16	100	PHP 6-D120TB	A-1	4545	2 1/4	4 1/2	11 13/16	1/2	4 1/2	6 13/16	125	PHP 8-D120TB
13,0	13,6	A-2	4040	1 3/4	4	8 15/16	1 1/2	4	3 7/16	100	PHP 6-D130TB	A-1	4545	2 1/4	4 1/2	11 13/16	1/2	4 1/2	6 13/16	155	PHP 8-D130TB
13,5	14,1	A-2	4040	1 3/4	4	8 15/16	1 1/2	4	3 7/16	107	PHP 6-D135TB	A-2	4545	2 1/4	4 1/2	11 13/16	1	4 1/2	6 13/16	150	PHP 8-D135TB
14,0	14,6	A-2	4040	1 3/4	4	8 15/16	1 1/2	4	3 7/16	112	PHP 6-D140TB	A-1	4545	2 1/4	4 1/2	11 13/16	1	4 1/2	6 13/16	155	PHP 8-D140TB
14,5	15,1	A-2	4040	1 3/4	4	8 15/16	1 1/2	4	3 7/16	117	PHP 6-D145TB	A-2	4545	2 1/4	4 1/2	11 13/16	2	4 1/2	5 7/16	155	PHP 8-D145TB
15,0	15,6	A-2	4040	1 3/4	4	8 15/16	1 1/2	4	3 7/16	122	PHP 6-D150TB	A-2	4545	2 1/4	4 1/2	11 13/16	2	4 1/2	5 7/16	135	PHP 8-D150TB
15,5	16,1	A-2	4040	1 3/4	4	8 15/16	1 1/2	4	3 7/16	127	PHP 6-D155TB	A-2	4545	2 1/4	4 1/2	11 13/16	2	4 1/2	5 7/16	165	PHP 8-D155TB
16,0	16,6	A-2	4040	1 3/4	4	8 15/16	1 1/2	4	3 7/16	175	PHP 6-D160TB	A-2	4545	2 1/4	4 1/2	11 13/16	2	4 1/2	5 7/16	165	PHP 8-D160TB
18,0	18,6	A-2	4040	1 3/4	4	8 15/16	1 1/2	4	3 7/16	185	PHP 6-D180TB	A-2	4545	2 1/4	4 1/2	11 13/16	2 3/4	4 1/2	4 7/16	180	PHP 8-D180TB
22,0	22,6	A-3	4040	1 3/4	4	8 15/16	1 1/2	4	3 7/16	210	PHP 6-D220TB	A-3	4545	2 1/4	4 1/2	11 13/16	2 3/4	4 1/2	4 7/16	275	PHP 8-D220TB
27,0	27,6	A-3	4545	2 1/4	4 1/2	8 15/16	1 3/4	4 1/2	2 11/16	260	PHP 6-D270TB	A-3	4545	2 1/4	4 1/2	11 13/16	2 3/4	4 1/2	4 7/16	345	PHP 8-D270TB
33,0	33,6	A-3	4545	2 1/4	4 1/2	8 15/16	1 3/4	4 1/2	2 11/16	340	PHP 6-D330TB	A-3	4545	2 1/4	4 1/2	11 13/16	2 3/4	4 1/2	4 7/16	455	PHP 8-D330TB

10 Groove

Pitch Diameter	Outside Diameter	Type	Bush	Bore		F	E	L	M	Weight	Designation
				Min	Max						
Inch	Inch			Inch	Inch	Inch	Inch	Inch	Inch	lbs	
12,0	12,6	A-1	4545	2 3/4	4 1/2	14 11/16	2 3/8	4 1/2	7 13/16	140	PHP 10-D120TB
13,0	13,6	A-1	4545	2 3/4	4 1/2	14 11/16	2 3/8	4 1/2	7 13/16	170	PHP 10-D130TB
13,5	14,1	A-2	4545	2 3/4	4 1/2	14 11/16	2 3/8	4 1/2	7 13/16	170	PHP 10-D135TB
14,0	14,6	A-2	4545	2 3/4	4 1/2	14 11/16	2 3/8	4 1/2	7 13/16	175	PHP 10-D140TB
14,5	15,1	A-2	4545	2 3/4	4 1/2	14 11/16	2 3/8	4 1/2	7 13/16	180	PHP 10-D145TB
15,0	15,6	A-2	4545	2 3/4	4 1/2	14 11/16	2 3/8	4 1/2	7 13/16	195	PHP 10-D150TB
15,5	16,1	A-2	4545	2 3/4	4 1/2	14 11/16	2 3/8	4 1/2	7 13/16	175	PHP 10-D155TB
16,0	16,6	A-2	4545	2 3/4	4 1/2	14 11/16	2 3/8	4 1/2	7 13/16	195	PHP 10-D160TB
18,0	18,6	A-2	4545	2 3/4	4 1/2	14 11/16	2 3/8	4 1/2	7 13/16	195	PHP 10-D180TB
22,0	22,6	A-3	4545	2 3/4	4 1/2	14 11/16	2 3/8	4 1/2	7 13/16	340	PHP 10-D220TB
27,0	27,6	A-3	4545	2 3/4	4 1/2	14 11/16	2 3/8	4 1/2	7 13/16	415	PHP 10-D270TB
33,0	33,6	A-3	4545	2 3/4	4 1/2	14 11/16	2 3/8	4 1/2	7 13/16	485	PHP 10-D330TB



Narrow wedge belt pulleys

3V taper bushed



Type B-1

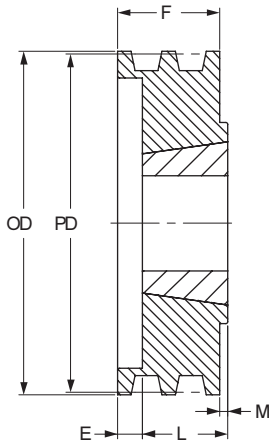

Type C-2

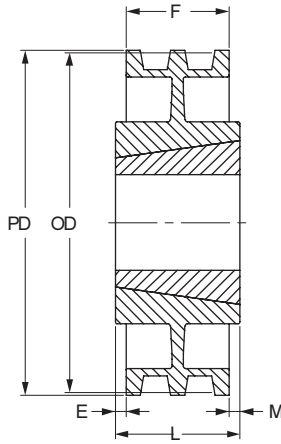

Type C-3

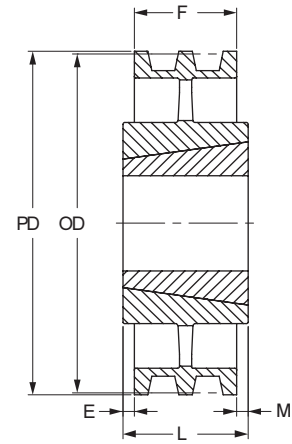

1 Groove

Outside Diameter	Pitch Diameter	Type	Bush	Bore		F	E	L	M	Weight	Designation
				Min	Max						
Inch	Inch			Inch	Inch	Inch	Inch	Inch	Inch	lbs	
2,65	2,60	B-1	1108	$\frac{3}{8}$	$1\frac{1}{8}$	$1\frac{1}{16}$	$\frac{7}{32}$	$\frac{7}{8}$	$1\frac{3}{32}$	0,75	PHP 1-3V265TB
2,80	2,75	B-1	1108	$\frac{3}{8}$	$1\frac{1}{8}$	$1\frac{3}{16}$	$\frac{7}{32}$	$\frac{7}{8}$	$1\frac{3}{32}$	0,85	PHP 1-3V280TB
3,00	2,95	B-1	1108	$\frac{3}{8}$	$1\frac{1}{8}$	$1\frac{1}{16}$	$\frac{7}{32}$	$\frac{7}{8}$	$1\frac{3}{32}$	1,00	PHP 1-3V300TB
3,15	3,10	B-1	1108	$\frac{3}{8}$	$1\frac{1}{8}$	$1\frac{1}{16}$	$\frac{7}{32}$	$\frac{7}{8}$	$1\frac{3}{32}$	1,00	PHP 1-3V315TB
3,35	3,30	B-1	1610	$\frac{1}{2}$	$1\frac{1}{8}$	$1\frac{1}{16}$	$\frac{3}{32}$	1	$1\frac{3}{32}$	1,10	PHP 1-3V335TB
3,65	3,60	B-1	1610	$\frac{1}{2}$	$1\frac{5}{8}$	$1\frac{1}{16}$	$\frac{3}{32}$	1	$1\frac{3}{32}$	1,30	PHP 1-3V365TB
4,12	4,07	B-1	1610	$\frac{1}{2}$	$1\frac{5}{8}$	$1\frac{1}{16}$	$\frac{3}{32}$	1	$1\frac{3}{32}$	2,00	PHP 1-3V412TB
4,50	4,45	B-1	1610	$\frac{1}{2}$	$1\frac{5}{8}$	$1\frac{1}{16}$	$\frac{3}{32}$	1	$1\frac{3}{32}$	2,30	PHP 1-3V450TB
4,75	4,70	B-1	1610	$\frac{1}{2}$	$1\frac{5}{8}$	$1\frac{1}{16}$	$\frac{3}{32}$	1	$1\frac{3}{32}$	2,60	PHP 1-3V475TB
5,00	4,95	B-1	1610	$\frac{1}{2}$	$1\frac{5}{8}$	$1\frac{1}{16}$	$\frac{3}{32}$	1	$1\frac{3}{32}$	2,90	PHP 1-3V500TB
5,30	5,25	B-1	1610	$\frac{1}{2}$	$1\frac{5}{8}$	$1\frac{1}{16}$	$\frac{3}{32}$	1	$1\frac{3}{32}$	3,30	PHP 1-3V530TB
5,60	5,55	B-1	1610	$\frac{1}{2}$	$1\frac{5}{8}$	$1\frac{1}{16}$	$\frac{3}{32}$	1	$1\frac{3}{32}$	3,70	PHP 1-3V560TB
6,00	5,95	B-1	1610	$\frac{1}{2}$	$1\frac{5}{8}$	$1\frac{1}{16}$	$\frac{3}{32}$	1	$1\frac{3}{32}$	4,20	PHP 1-3V600TB
6,50	6,45	B-1	1610	$\frac{1}{2}$	$1\frac{5}{8}$	$1\frac{1}{16}$	$\frac{3}{32}$	1	$1\frac{3}{32}$	5,00	PHP 1-3V650TB
6,90	6,85	B-1	1610	$\frac{1}{2}$	$1\frac{5}{8}$	$1\frac{1}{16}$	$\frac{3}{32}$	1	$1\frac{3}{32}$	5,00	PHP 1-3V690TB
8,00	7,95	C-2	2517	$\frac{3}{4}$	$2\frac{1}{2}$	$1\frac{1}{16}$	0	$1\frac{3}{4}$	$1\frac{3}{32}$	8,50	PHP 1-3V800TB
10,60	10,55	C-2	2517	$\frac{3}{4}$	$2\frac{1}{2}$	$1\frac{1}{16}$	0	$1\frac{3}{4}$	$1\frac{3}{32}$	14,00	PHP 1-3V1060TB
14,00	13,95	C-3	2517	$\frac{3}{4}$	$2\frac{1}{2}$	$1\frac{1}{16}$	0	$1\frac{3}{4}$	$1\frac{3}{32}$	20,00	PHP 1-3V1400TB
19,00	18,95	C-3	3020	$1\frac{1}{4}$	3	$1\frac{1}{16}$	0	2	$1\frac{3}{32}$	26,00	PHP 1-3V1900TB

2 Groove

Outside Diameter	Pitch Diameter	Type	Bush	Bore		F	E	L	M	Weight	Designation
				Min	Max						
Inch	Inch			Inch	Inch	Inch	Inch	Inch	Inch	lbs	
2,65	2,60	B-1	1108	$\frac{3}{8}$	$1\frac{1}{8}$	$1\frac{3}{32}$	$\frac{7}{32}$	$\frac{7}{8}$	0	0,75	PHP 2-3V265TB
2,80	2,75	B-1	1108	$\frac{3}{8}$	$1\frac{1}{8}$	$1\frac{3}{32}$	$\frac{1}{2}$	$\frac{7}{8}$	$1\frac{3}{32}$	0,90	PHP 2-3V280TB
3,00	2,95	B-1	1210	$\frac{5}{8}$	$1\frac{1}{4}$	$1\frac{3}{32}$	$\frac{3}{32}$	1	0	1,40	PHP 2-3V300TB
3,15	3,10	B-1	1210	$\frac{5}{8}$	$1\frac{1}{4}$	$1\frac{3}{32}$	$\frac{1}{2}$	1	$1\frac{3}{32}$	1,00	PHP 2-3V315TB
3,35	3,30	B-1	1610	$\frac{1}{2}$	$1\frac{1}{8}$	$1\frac{3}{32}$	$\frac{1}{2}$	1	$1\frac{3}{32}$	1,50	PHP 2-3V335TB
3,65	3,60	B-1	1610	$\frac{1}{2}$	$1\frac{1}{8}$	$1\frac{3}{32}$	$\frac{3}{32}$	1	0	1,60	PHP 2-3V365TB
4,12	4,07	B-1	1610	$\frac{1}{2}$	$1\frac{5}{8}$	$1\frac{3}{32}$	$\frac{3}{32}$	1	0	2,10	PHP 2-3V412TB
4,50	4,45	B-1	1610	$\frac{1}{2}$	$1\frac{5}{8}$	$1\frac{3}{32}$	$\frac{3}{32}$	1	0	2,70	PHP 2-3V450TB
4,75	4,70	B-1	1610	$\frac{1}{2}$	$1\frac{5}{8}$	$1\frac{3}{32}$	$\frac{3}{32}$	1	0	3,10	PHP 2-3V475TB
5,00	4,95	B-1	1610	$\frac{1}{2}$	$1\frac{5}{8}$	$1\frac{3}{32}$	$\frac{3}{32}$	1	0	3,60	PHP 2-3V500TB
5,30	5,25	B-1	1610	$\frac{1}{2}$	$1\frac{5}{8}$	$1\frac{3}{32}$	$\frac{3}{32}$	1	0	4,20	PHP 2-3V530TB
5,60	5,55	B-1	1610	$\frac{1}{2}$	$1\frac{5}{8}$	$1\frac{3}{32}$	$\frac{3}{32}$	1	0	4,80	PHP 2-3V560TB
6,00	5,95	B-1	1610	$\frac{1}{2}$	$1\frac{5}{8}$	$1\frac{3}{32}$	$\frac{3}{32}$	1	0	5,80	PHP 2-3V600TB
6,50	6,45	B-1	1610	$\frac{1}{2}$	$1\frac{5}{8}$	$1\frac{3}{32}$	$\frac{3}{32}$	1	0	7,00	PHP 2-3V650TB
6,90	6,85	B-1	1610	$\frac{1}{2}$	$1\frac{5}{8}$	$1\frac{3}{32}$	$\frac{3}{32}$	1	0	8,00	PHP 2-3V690TB
8,00	7,95	C-2	2517	$\frac{3}{4}$	$2\frac{1}{2}$	$1\frac{3}{32}$	0	$1\frac{3}{4}$	$2\frac{1}{32}$	11,00	PHP 2-3V800TB
10,60	10,55	C-2	2517	$\frac{3}{4}$	$2\frac{1}{2}$	$1\frac{3}{32}$	0	$1\frac{3}{4}$	$2\frac{1}{32}$	15,00	PHP 2-3V1060TB
14,00	13,95	C-3	2517	$\frac{3}{4}$	$2\frac{1}{2}$	$1\frac{3}{32}$	0	$1\frac{3}{4}$	$2\frac{1}{32}$	22,00	PHP 2-3V1400TB
19,00	18,95	C-3	3020	$1\frac{1}{4}$	3	$1\frac{3}{32}$	$\frac{1}{8}$	2	$2\frac{1}{32}$	32,00	PHP 2-3V1900TB
25,00	24,95	C-3	3020	$1\frac{1}{4}$	3	$1\frac{3}{32}$	$\frac{1}{8}$	2	$2\frac{1}{32}$	45,00	PHP 2-3V2500TB



Narrow wedge belt pulleys

3V taper bushed

- ▶ Belts
- ▶ Chains
- ▶ Couplings
- ▶ Bushings and Hubs
- ▶ Sprockets
- ▶ Pulleys
- ▶ Smart tools

Type A-2

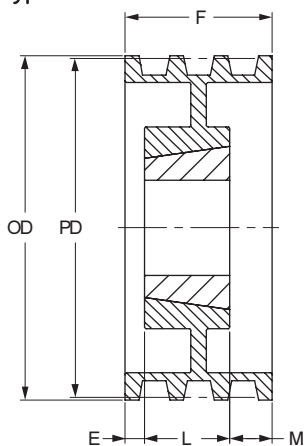

Type B-1

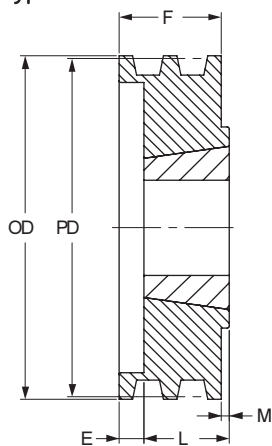

Type C-2

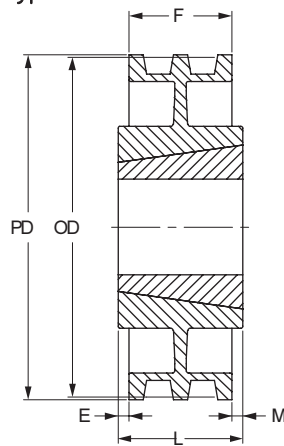

Type C-3

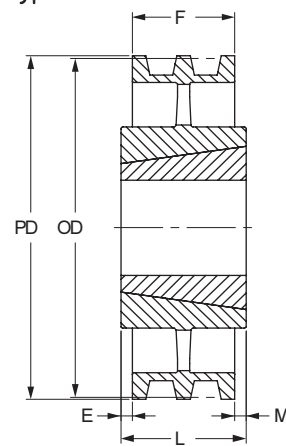

3 Groove

Outside Diameter	Pitch Diameter	Type	Bush	Bore		F	E	L	M	Weight	Designation
				Min	Max						
Inch	Inch			Inch	Inch	Inch	Inch	Inch	Inch	lbs	
2,80	2,75	B-1	1108	3/8	1 1/8	1 1/2	5/8	7/8	1 3/32	1,1	PHP 3-3V280TB
3,00	2,95	B-1	1210	5/8	1 1/4	1 1/2	29/32	1	-	1,8	PHP 3-3V300TB
3,15	3,10	B-1	1210	5/8	1 1/4	1 1/2	1/2	1	1 3/32	1,5	PHP 3-3V315TB
3,35	3,30	B-1	1610	1/2	1 5/8	1 1/2	29/32	1	1 3/32	1,8	PHP 3-3V335TB
3,65	3,60	B-1	1610	1/2	1 5/8	1 1/2	29/32	1	-	2,0	PHP 3-3V365TB
4,12	4,07	B-1	1610	1/2	1 5/8	1 1/2	1/2	1	-	2,6	PHP 3-3V412TB
4,50	4,45	B-1	1610	1/2	1 5/8	1 1/2	1/2	1	-	3,2	PHP 3-3V450TB
4,75	4,70	B-1	1610	1/2	1 5/8	1 1/2	1/2	1	-	3,7	PHP 3-3V475TB
5,00	4,95	B-1	1610	1/2	1 5/8	1 1/2	1/2	1	-	4,2	PHP 3-3V500TB
5,30	5,25	B-1	1610	1/2	1 5/8	1 1/2	1/2	1	-	4,8	PHP 3-3V530TB
5,60	5,55	B-1	1610	1/2	1 5/8	1 1/2	1/2	1	-	5,5	PHP 3-3V560TB
6,00	5,95	B-1	2517	3/4	2 1/2	1 1/2	5/32	1 3/4	13/32	7,4	PHP 3-3V600TB
6,50	6,45	B-1	2517	3/4	2 1/2	1 1/2	5/32	1 3/4	13/32	9,1	PHP 3-3V650TB
6,90	6,85	B-1	2517	3/4	2 1/2	1 1/2	5/32	1 3/4	13/32	10,0	PHP 3-3V690TB
8,00	7,95	C-2	2517	3/4	2 1/2	1 1/2	5/32	1 3/4	13/32	15,0	PHP 3-3V800TB
10,60	10,55	C-2	2517	3/4	2 1/2	1 1/2	-	1 3/4	3/4	18,0	PHP 3-3V1060TB
14,00	13,95	C-3	2517	3/4	2 1/2	1 1/2	-	1 3/4	3/4	25,0	PHP 3-3V1400TB
19,00	18,95	C-3	3020	1 1/4	3	1 1/2	-	2	1/2	34,0	PHP 3-3V1900TB
25,00	24,95	C-3	3020	1 1/4	3	1 1/2	-	2	1/2	49,0	PHP 3-3V2500TB
33,50	33,45	C-3	3020	1 1/4	3	1 1/2	1/4	2	3/4	67,0	PHP 3-3V3350TB

4 Groove

Outside Diameter	Pitch Diameter	Type	Bush	Bore		F	E	L	M	Weight	Designation
				Min	Max						
Inch	Inch			Inch	Inch	Inch	Inch	Inch	Inch	lbs	
2,80	2,75	B-1	1108	3/8	1 1/8	1 29/32	1 5/16	7/8	1 3/32	1,3	PHP 4-3V280TB
3,00	2,95	B-1	1210	5/8	1 1/4	1 29/32	29/32	1	-	2,1	PHP 4-3V300TB
3,15	3,10	B-1	1210	5/8	1 1/4	1 29/32	1 5/16	1	1 3/32	1,9	PHP 4-3V315TB
3,35	3,30	B-1	1610	1/2	1 5/8	1 29/32	29/32	1	-	2,2	PHP 4-3V335TB
3,65	3,60	B-1	1610	1/2	1 5/8	1 29/32	29/32	1	-	2,0	PHP 4-3V365TB
4,12	4,07	B-1	1610	1/2	1 5/8	1 29/32	29/32	1	-	3,0	PHP 4-3V412TB
4,50	4,45	B-1	1610	1/2	1 5/8	1 29/32	29/32	1	-	3,7	PHP 4-3V450TB
4,75	4,70	B-1	1610	1/2	1 5/8	1 29/32	29/32	1	-	4,2	PHP 4-3V475TB
5,00	4,95	B-1	1610	1/2	1 5/8	1 29/32	29/32	1	-	4,8	PHP 4-3V500TB
5,30	5,25	B-1	1610	1/2	1 5/8	1 29/32	29/32	1	-	5,5	PHP 4-3V530TB
5,60	5,55	B-1	1610	1/2	1 5/8	1 29/32	29/32	1	-	6,2	PHP 4-3V560TB
6,00	5,95	B-1	2517	3/4	2 1/2	1 29/32	5/32	1 3/4	-	8,0	PHP 4-3V600TB
6,50	6,45	B-1	2517	3/4	2 1/2	1 29/32	5/32	1 3/4	-	10,0	PHP 4-3V650TB
6,90	6,85	B-1	2517	3/4	2 1/2	1 29/32	5/32	1 3/4	-	12,0	PHP 4-3V690TB
8,00	7,95	B-1	2517	3/4	2 1/2	1 29/32	5/32	1 3/4	-	18,0	PHP 4-3V800TB
10,60	10,55	A-2	2517	3/4	2 1/2	1 29/32	5/32	1 3/4	-	20,0	PHP 4-3V1060TB
14,00	13,95	C-3	2517	3/4	2 1/2	1 29/32	0	1 3/4	5/32	29,0	PHP 4-3V1400TB
19,00	18,95	C-3	3020	1 1/4	3	1 29/32	0	3	1 3/32	45,0	PHP 4-3V1900TB
25,00	24,95	C-3	3020	1 1/4	3	1 29/32	0	3	1 3/32	63,0	PHP 4-3V2500TB
33,50	33,45	C-3	3030	1 1/4	3	1 29/32	35/64	3	35/64	81,0	PHP 4-3V3350TB



Narrow wedge belt pulleys

3V taper bushed



Type A-1

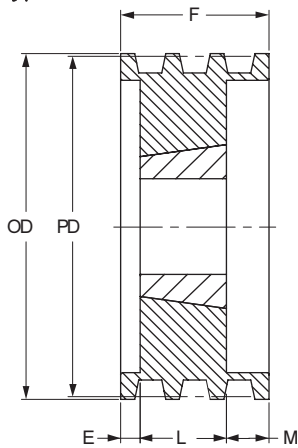

Type A-2

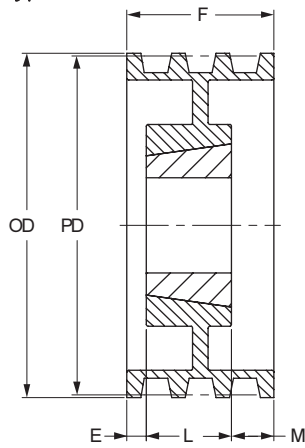

Type A-3

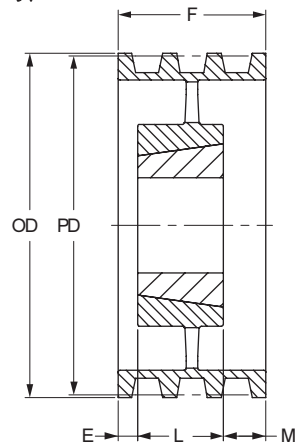

Type B-1

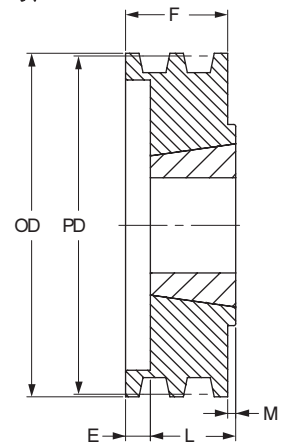

5 Groove

Outside Diameter	Pitch Diameter	Type	Bush	Bore		F	E	L	M	Weight	Designation	Type	Bush	Bore		F	E	L	M	Weight	Designation
				Min	Max									Min	Max						
4,75	4,70	B-1	2517	3/4	2 1/2	2 15/16	9/16	1 3/4	0	3,8	PHP 5-3V475TB	B-1	2517	3/4	2 1/2	2 23/32	31/32	1 3/4	0	4,4	PHP 6-3V475TB
5,00	4,95	B-1	2517	3/4	2 1/2	2 15/16	9/16	1 3/4	0	4,8	PHP 5-3V500TB	B-1	2517	3/4	2 1/2	2 23/32	31/32	1 3/4	0	5,4	PHP 6-3V500TB
5,30	5,25	B-1	2517	3/4	2 1/2	2 15/16	9/16	1 3/4	0	5,9	PHP 5-3V530TB	B-1	2517	3/4	2 1/2	2 23/32	31/32	1 3/4	0	6,5	PHP 6-3V530TB
5,60	5,55	B-1	2517	3/4	2 1/2	2 15/16	9/16	1 3/4	0	7,0	PHP 5-3V560TB	B-1	2517	3/4	2 1/2	2 23/32	31/32	1 3/4	0	7,7	PHP 6-3V560TB
6,00	5,95	B-1	2517	3/4	2 1/2	2 15/16	9/16	1 3/4	0	8,7	PHP 5-3V600TB	B-1	2517	3/4	2 1/2	2 23/32	31/32	1 3/4	0	9,5	PHP 6-3V600TB
6,50	6,45	B-1	2517	3/4	2 1/2	2 15/16	9/16	1 3/4	0	11,0	PHP 5-3V650TB	B-1	2517	3/4	2 1/2	2 23/32	31/32	1 3/4	0	12,0	PHP 6-3V650TB
6,90	6,85	B-1	2517	3/4	2 1/2	2 15/16	9/16	1 3/4	0	13,0	PHP 5-3V690TB	B-1	2517	3/4	2 1/2	2 23/32	31/32	1 3/4	0	13,0	PHP 6-3V690TB
8,00	7,95	B-1	2517	3/4	2 1/2	2 15/16	9/16	1 3/4	0	19,0	PHP 5-3V800TB	B-1	2517	3/4	2 1/2	2 23/32	31/32	1 3/4	0	20,0	PHP 6-3V800TB
10,60	10,55	B-2	2517	3/4	2 1/2	2 15/16	9/16	1 3/4	0	26,0	PHP 5-3V1060TB	B-2	2517	3/4	2 1/2	2 23/32	31/32	1 3/4	0	29,0	PHP 6-3V1060TB
14,00	13,95	C-3	2517	3/4	2 1/2	2 15/16	9/16	1 3/4	0	34,0	PHP 5-3V1400TB	B-3	2517	3/4	2 1/2	2 23/32	7/32	1 3/4	3/4	41,0	PHP 6-3V1400TB
19,00	18,95	C-3	3030	1 1/4	3	2 15/16	9/16	1 3/4	0,69	47,0	PHP 5-3V1900TB	C-3	3020	1 1/4	3	2 23/32	0	3	9/32	51,0	PHP 6-3V1900TB
25,00	24,95	C-3	3030	1 1/4	3	2 15/16	9/16	1 3/4	0	66,0	PHP 5-3V2500TB	C-3	3020	1 1/4	3	2 23/32	0	3	9/32	72,0	PHP 6-3V2500TB
33,50	33,45	C-3	3030	1 1/4	3	2 15/16	11/32	3	11/16	86,0	PHP 5-3V3350TB	C-3	3030	1 1/4	3	2 23/32	9/64	3	9/64	92,0	PHP 6-3V3350TB

6 Groove

8 Groove

Outside Diameter	Pitch Diameter	Type	Bush	Bore		F	E	L	M	Weight	Designation
				Min	Max						
4,75	4,70	B-1	2517	3/4	2 1/2	3 17/32	1 25/32	1 3/4	0	5,8	PHP 8-3V475TB
5,00	4,95	B-1	2517	3/4	2 1/2	3 17/32	1 25/32	1 3/4	0	6,4	PHP 8-3V500TB
5,30	5,25	A-1	2517	3/4	2 1/2	3 17/32	1 1 1/32	1 3/4	3/4	7,8	PHP 8-3V530TB
5,60	5,55	A-1	2517	3/4	2 1/2	3 17/32	1 3/4	1 3/4	1 17/32	9,2	PHP 8-3V560TB
6,00	5,95	A-1	2517	3/4	2 1/2	3 17/32	1 3/4	1 3/4	1 17/32	11,0	PHP 8-3V600TB
6,50	6,45	A-1	2517	3/4	2 1/2	3 17/32	1 3/4	1 3/4	1 17/32	14,0	PHP 8-3V650TB
6,90	6,85	A-1	2517	3/4	2 1/2	3 17/32	1 3/4	1 3/4	1 17/32	16,0	PHP 8-3V690TB
8,00	7,95	A-1	3020	1 1/4	3	3 17/32	1 1/2	2	1 1/32	22,0	PHP 8-3V800TB
10,60	10,55	A-2	3020	1 1/4	3	3 17/32	1 1/2	2	1 1/32	28,0	PHP 8-3V1060TB
14,00	13,95	A-3	3020	1 1/4	3	3 17/32	0	3	17/32	52,0	PHP 8-3V1400TB
19,00	18,95	A-3	3535	2	3 15/16	3 17/32	0	3 1/2	1/32	67,0	PHP 8-3V1900TB
25,00	24,95	A-3	3535	2	3 15/16	3 17/32	0	3 1/2	1/32	93,0	PHP 8-3V2500TB
33,50	33,45	C-3	4040	1 3/4	4 7/16	3 17/32	15/16	4	15/16	157,0	PHP 8-3V3350TB

10 Groove

Outside Diameter	Pitch Diameter	Type	Bush	Bore		F	E	L	M	Weight	Designation
				Min	Max						
4,75	4,70	B-1	2517	3/4	2 1/2	4 11/32	2 11/32	1 3/4	0	7	PHP 10-3V475TB
5,00	4,95	B-1	2517	3/4	2 1/2	4 11/32	2 11/32	1 3/4	3/4	8	PHP 10-3V500TB
5,30	5,25	A-1	2517	3/4	2 1/2	4 11/32	2 11/32	1 3/4	0	9	PHP 10-3V530TB
5,60	5,55	A-1	2517	3/4	2 1/2	4 11/32	1 1/2	1 3/4	2 3/32	11	PHP 10-3V560TB
6,00	5,95	A-1	2517	3/4	2 1/2	4 11/32	1 1/2	1 3/4	2 3/32	13	PHP 10-3V600TB
6,50	6,45	A-1	2517	3/4	2 1/2	4 11/32	1 1/2	1 3/4	2 3/32	15	PHP 10-3V650TB
6,90	6,85	A-1	2517	3/4	2 1/2	4 11/32	1 1/2	1 3/4	2 3/32	18	PHP 10-3V690TB
8,00	7,95	A-1	3020	1 1/4	3	4 11/32	1 1/2	2	2 3/32	23	PHP 10-3V800TB
10,60	10,55	A-2	3020	1 1/4	3	4 11/32	2 1/2	2	1 1/2	31	PHP 10-3V1060TB
14,00	13,95	A-2	3535	2	3 1/2	4 11/32	0	3 1/2	27/32	50	PHP 10-3V1400TB
19,00	18,95	A-3	3535	2	3 1/2	4 11/32	0	3 1/2	27/32	75	PHP 10-3V1900TB
25,00	24,95	A-3	4040	1 3/4	4 7/16	4 11/32	0	4	11/32	122	PHP 10-3V2500TB
33,50	33,45	A-3	4040	1 3/4	4 7/16	4 11/32	11/64	4	11/64	172	PHP 10-3V3350TB



Narrow wedge belt pulleys

5V taper bushed

- ▶ Belts
- ▶ Chains
- ▶ Couplings
- ▶ Bushings and Hubs
- ▶ Sprockets
- ▶ Pulleys
- ▶ Smart tools

Type B-2

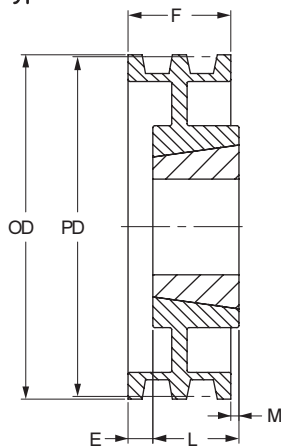

Type B-3

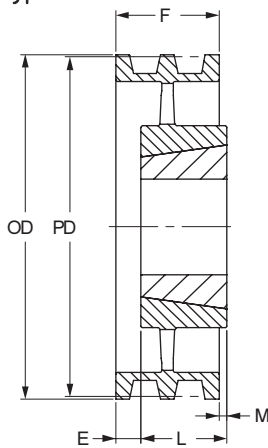

Type C-3

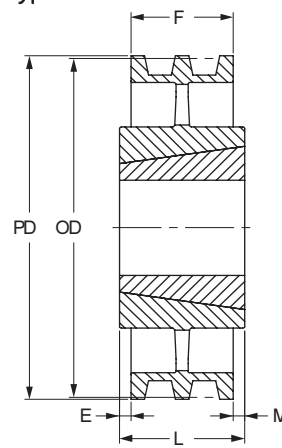

2 Groove

Outside Diameter	Pitch Diameter	Type	Bush	Bore		F	E	L	M	Weight	Designation
				Min	Max						
Inch	Inch			Inch	Inch	Inch	Inch	Inch	Inch	lbs	
7,10	7,05	B-1	2517	3/4	2 1/2	1 11/16	1/16	1 3/4	-	10	PHP 2-5V710TB
7,50	7,45	B-1	2517	3/4	2 1/2	1 11/16	1/16	1 3/4	-	12	PHP 2-5V750TB
8,00	7,95	B-1	2517	3/4	2 1/2	1 11/16	1/16	1 3/4	-	14	PHP 2-5V800TB
8,50	8,45	B-2	2517	3/4	2 1/2	1 11/16	1/16	1 3/4	-	13	PHP 2-5V850TB
9,00	8,95	B-2	2517	3/4	2 1/2	1 11/16	1/16	1 3/4	-	16	PHP 2-5V900TB
9,25	9,20	C-2	3020	1 1/4	3	1 11/16	-	2	5/16	17	PHP 2-5V925TB
9,75	9,70	C-2	3020	1 1/4	3	1 11/16	-	2	5/16	19	PHP 2-5V975TB
10,30	10,25	C-2	3020	1 1/4	3	1 11/16	-	2	5/16	22	PHP 2-5V1030TB
10,90	10,85	C-2	3020	1 1/4	3	1 11/16	-	2	5/16	24	PHP 2-5V1090TB
11,80	11,75	C-2	3020	1 1/4	3	1 11/16	-	2	5/16	26	PHP 2-5V1180TB
12,50	12,45	C-2	3020	1 1/4	3	1 11/16	-	2	5/16	28	PHP 2-5V1250TB
13,20	13,15	C-3	3020	1 1/4	3	1 11/16	-	2	5/16	21	PHP 2-5V1320TB
14,00	13,95	C-3	3020	1 1/4	3	1 11/16	-	2	5/16	23	PHP 2-5V1400TB
15,00	14,95	C-3	3020	1 1/4	3	1 11/16	-	2	5/16	26	PHP 2-5V1500TB
16,00	15,95	C-3	3020	1 1/4	3	1 11/16	-	2	5/16	28	PHP 2-5V1600TB
21,20	21,15	C-3	3535	2	3 15/16	1 11/16	3/8	3 1/2	1 1/16	51	PHP 2-5V2120TB
28,00	27,95	C-3	3535	2	3 15/16	1 11/16	3/8	3 1/2	1 1/16	69	PHP 2-5V2800TB

3 Groove

Outside Diameter	Pitch Diameter	Type	Bush	Bore		F	E	L	M	Weight	Designation
				Min	Max						
Inch	Inch			Inch	Inch	Inch	Inch	Inch	Inch	lbs	
7,10	7,05	B-1	2517	3/4	2 1/2	2 3/8	5/8	1 3/4	-	13	PHP 3-5V710TB
7,50	7,45	B-1	2517	3/4	2 1/2	2 3/8	5/8	1 3/4	-	15	PHP 3-5V750TB
8,00	7,95	B-1	2517	3/4	2 1/2	2 3/8	5/8	1 3/4	-	18	PHP 3-5V800TB
8,50	8,45	B-2	2517	3/4	2 1/2	2 3/8	5/8	1 3/4	-	20	PHP 3-5V850TB
9,00	8,95	B-2	2517	3/4	2 1/2	2 3/8	5/8	1 3/4	-	20	PHP 3-5V900TB
9,25	9,20	A-2	3020	1 1/4	3	2 3/8	-	2	3/8	21	PHP 3-5V925TB
9,75	9,70	A-2	3020	1 1/4	3	2 3/8	-	2	3/8	24	PHP 3-5V975TB
10,30	10,25	A-2	3020	1 1/4	3	2 3/8	-	2	3/8	25	PHP 3-5V1030TB
10,90	10,85	A-2	3020	1 1/4	3	2 3/8	-	2	3/8	27	PHP 3-5V1090TB
11,80	11,75	A-2	3020	1 1/4	3	2 3/8	-	2	3/8	29	PHP 3-5V1180TB
12,50	12,45	A-3	3020	1 1/4	3	2 3/8	-	2	3/8	32	PHP 3-5V1250TB
13,20	13,15	A-3	3020	1 1/4	3	2 3/8	-	2	3/8	34	PHP 3-5V1320TB
14,00	13,95	A-3	3020	1 1/4	3	2 3/8	-	2	3/8	36	PHP 3-5V1400TB
15,00	14,95	A-3	3020	1 1/4	3	2 3/8	-	2	3/8	37	PHP 3-5V1500TB
16,00	15,95	A-3	3020	1 1/4	3	2 3/8	-	2	3/8	38	PHP 3-5V1600TB
21,20	21,15	C-3	3535	2	3 15/16	2 3/8	-	3 1/2	1 1/8	65	PHP 3-5V2120TB
28,00	27,95	C-3	3535	2	3 15/16	2 3/8	-	3 1/2	1 1/8	93	PHP 3-5V2800TB
37,50	37,40	C-3	4040	1 3/4	4 7/16	2 3/4	1/2	4	1 1/8	142	PHP 3-5V3750TB
50,00	49,90	C-3	4040	1 3/4	4 7/16	2 3/8	1/2	4	1 1/8	202	PHP 3-5V5000TB



Narrow wedge belt pulleys

5V taper bushed



Type A-1

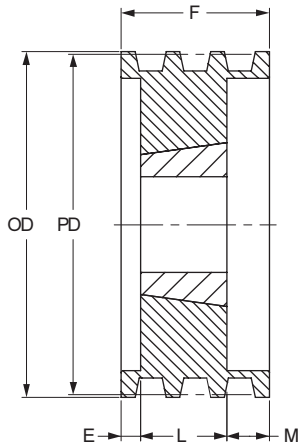

Type A-2

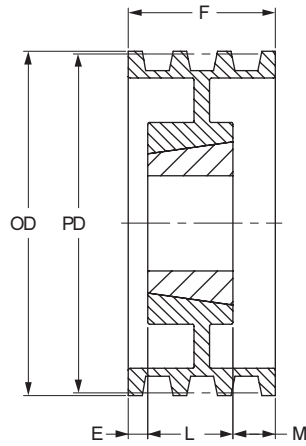

Type A-3

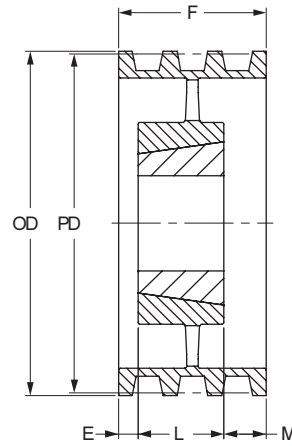

Type B-1

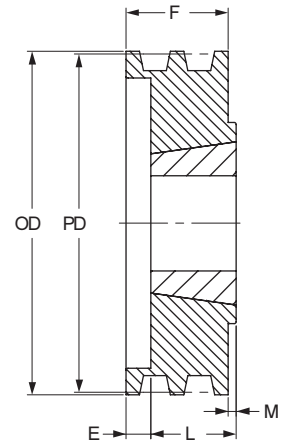

4 Groove

Outside Diameter	Pitch Diameter	Type	Bush	Bore		F	E	L	M	Weight	Designation
				Min	Max						
Inch	Inch			Inch	Inch	Inch	Inch	Inch	Inch	lbs	
7,10	7,05	B-1	2517	3/4	2 1/2	3 1/16	1 5/16	1 3/4	0	15	PHP 4-5V710TB
7,50	7,45	B-1	2517	3/4	2 1/2	3 1/16	1 5/16	1 3/4	-	18	PHP 4-5V750TB
8,00	7,95	B-1	2517	3/4	2 1/2	3 1/16	1 5/16	1 3/4	-	21	PHP 4-5V800TB
8,50	8,45	B-2	2517	3/4	2 1/2	3 1/16	1 5/16	1 3/4	-	20	PHP 4-5V850TB
9,00	8,95	B-2	2517	3/4	2 1/2	3 1/16	1 5/16	1 3/4	-	22	PHP 4-5V900TB
9,25	9,20	A-1	3020	1 1/4	3	3 1/16	1 1/2	2	9/16	27	PHP 4-5V925TB
9,75	9,70	A-1	3020	1 1/4	3	3 1/16	1 1/2	2	9/16	31	PHP 4-5V975TB
10,30	10,25	A-2	3020	1 1/4	3	3 1/16	1 1/2	2	9/16	28	PHP 4-5V1030TB
10,90	10,85	A-2	3020	1 1/4	3	3 1/16	1 1/2	2	9/16	31	PHP 4-5V1090TB
11,80	11,75	A-2	3020	1 1/4	3	3 1/16	1 1/2	2	9/16	34	PHP 4-5V1180TB
12,50	12,45	A-2	3020	1 1/4	3	3 1/16	-	3	1/16	40	PHP 4-5V1250TB
13,20	13,15	A-3	3020	1 1/4	3	3 1/16	-	3	1/16	42	PHP 4-5V1320TB
14,00	13,95	C-2	3535	2	3 15/16	3 1/16	-	3 1/2	7/16	48	PHP 4-5V1400TB
15,00	14,95	C-3	3535	2	3 15/16	3 1/16	-	3 1/2	7/16	52	PHP 4-5V1500TB
16,00	15,95	C-3	3535	2	3 15/16	3 1/16	-	3 1/2	7/16	53	PHP 4-5V1600TB
21,20	21,15	C-3	3535	2	3 15/16	3 1/16	-	3 1/2	7/16	72	PHP 4-5V2120TB
28,00	27,95	C-3	3535	2	3 15/16	3 1/16	-	3 1/2	7/16	103	PHP 4-5V2800TB
37,50	37,45	C-3	4040	1 3/4	4 7/16	3 1/16	-	4	15/16	172	PHP 4-5V3750TB
50,00	49,95	C-3	4040	1 3/4	4 7/16	3 1/16	-	4	15/16	222	PHP 4-5V5000TB

5 Groove

Outside Diameter	Pitch Diameter	Type	Bush	Bore		F	E	L	M	Weight	Designation
				Min	Max						
Inch	Inch			Inch	Inch	Inch	Inch	Inch	Inch	lbs	
7,10	7,00	A-1	3020	1 1/4	3	3 3/4	1/2	2	1 1/4	16	PHP 5-5V710TB
7,50	7,40	A-1	3020	1 1/4	3	3 3/4	1/2	2	1 1/4	18	PHP 5-5V750TB
8,00	7,90	A-1	3020	1 1/4	3	3 3/4	1/2	2	1 1/4	22	PHP 5-5V800TB
8,50	8,40	A-1	3020	1 1/4	3	3 3/4	1/2	2	1 1/4	26	PHP 5-5V850TB
9,00	8,90	A-1	3020	1 1/4	3	3 3/4	1/2	2	1 1/4	29	PHP 5-5V900TB
9,25	9,15	A-1	3020	1 1/4	3	3 3/4	1/2	2	1 1/4	30	PHP 5-5V925TB
9,75	9,65	A-1	3020	1 1/4	3	3 3/4	1/2	2	1 1/4	34	PHP 5-5V975TB
10,30	10,20	A-2	3020	1 1/4	3	3 3/4	1/2	2	1 1/4	32	PHP 5-5V1030TB
10,90	10,80	A-2	3020	1 1/4	3	3 3/4	1/2	2	1 1/4	34	PHP 5-5V1090TB
11,80	11,70	A-2	3020	1 1/4	3	3 3/4	1/2	2	1 1/4	39	PHP 5-5V1180TB
12,50	12,40	A-2	3535	2	3 15/16	3 3/4	-	3 1/2	1/4	54	PHP 5-5V1250TB
13,20	13,10	A-2	3535	2	3 15/16	3 3/4	-	3 1/2	1/4	57	PHP 5-5V1320TB
14,00	13,90	A-2	3535	2	3 15/16	3 3/4	-	3 1/2	1/4	54	PHP 5-5V1400TB
15,00	14,90	A-3	3535	2	3 15/16	3 3/4	-	3 1/2	1/4	56	PHP 5-5V1500TB
16,00	15,90	A-3	3535	2	3 15/16	3 3/4	-	3 1/2	1/4	58	PHP 5-5V1600TB
21,20	21,10	C-3	4040	1 3/4	4 7/16	3 3/4	-	4	1/4	92	PHP 5-5V2120TB
28,00	27,90	C-3	4040	1 3/4	4 7/16	3 3/4	-	4	1/4	117	PHP 5-5V2800TB
37,50	37,40	C-3	4040	1 3/4	4 7/16	3 3/4	-	4	1/4	182	PHP 5-5V3750TB
50,00	49,90	C-3	4545	2 1/4	4 15/16	3 3/4	-	4 1/2	3/4	276	PHP 5-5V5000TB



Narrow wedge belt pulleys

5V taper bushed

- ▶ Belts
- ▶ Chains
- ▶ Couplings
- ▶ Bushings and Hubs
- ▶ Sprockets
- ▶ Pulleys
- ▶ Smart tools

6 Groove

Outside Diameter	Pitch Diameter	Type	Bush	Bore		F	E	L	M	Weight	Designation
				Min	Max						
Inch	Inch			Inch	Inch	Inch	Inch	Inch	Inch	lbs	
7,10	7,00	A-1	3020	1 1/4	3	4 7/16	3/4	2	1 11/16	18	PHP 6-5V710 TB
7,50	7,40	A-1	3020	1 1/4	3	4 7/16	3/4	2	1 11/16	20	PHP 6-5V750 TB
8,00	7,90	A-1	3020	1 1/4	3	4 7/16	3/4	2	1 11/16	24	PHP 6-5V800 TB
8,50	8,40	A-1	3020	1 1/4	3	4 7/16	3/4	2	1 11/16	28	PHP 6-5V850 TB
9,00	8,90	A-1	3020	1 1/4	3	4 7/16	3/4	2	1 11/16	30	PHP 6-5V900 TB
9,25	9,15	A-1	3535	2	3 15/16	4 7/16	-	3 1/2	1 15/16	39	PHP 6-5V925 TB
9,75	9,65	A-1	3535	2	3 15/16	4 7/16	-	3 1/2	1 15/16	46	PHP 6-5V975 TB
10,30	10,20	A-1	3535	2	3 15/16	4 7/16	-	3 1/2	1 15/16	54	PHP 6-5V1030 TB
10,90	10,80	A-1	3535	2	3 15/16	4 7/16	-	3 1/2	1 15/16	62	PHP 6-5V1090 TB
11,80	11,70	A-2	3535	2	3 15/16	4 7/16	-	3 1/2	1 15/16	55	PHP 6-5V1180 TB
12,50	12,40	A-2	3535	2	3 15/16	4 7/16	-	3 1/2	1 15/16	58	PHP 6-5V1250 TB
13,20	13,10	A-2	3535	2	3 15/16	4 7/16	-	3 1/2	1 15/16	60	PHP 6-5V1320 TB
14,00	13,90	A-2	3535	2	3 15/16	4 7/16	-	3 1/2	1 15/16	59	PHP 6-5V1400 TB
15,00	14,90	A-2	4040	1 3/4	4 7/16	4 7/16	-	4	1 7/16	82	PHP 6-5V1500 TB
16,00	15,90	A-2	4040	1 3/4	4 7/16	4 7/16	-	4	1 7/16	87	PHP 6-5V1600 TB
21,20	21,10	A-3	4040	1 3/4	4 7/16	4 7/16	-	4	1 7/16	102	PHP 6-5V2120 TB
28,00	27,90	A-3	4040	1 3/4	4 7/16	4 7/16	-	4	1 7/16	137	PHP 6-5V2800 TB
37,50	37,40	C-3	4545	2 1/4	4 15/16	4 7/16	-	4 1/2	1 3/16	221	PHP 6-5V3750 TB
50,00	49,90	C-3	4545	2 1/4	4 15/16	4 7/16	-	4 1/2	1 3/16	296	PHP 6-5V5000 TB

Type B-2

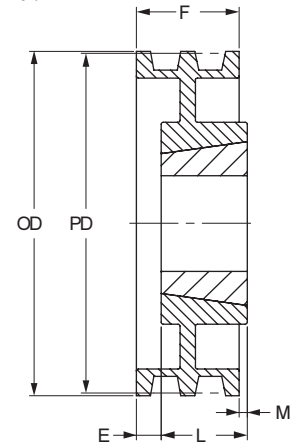

8 Groove

Outside Diameter	Pitch Diameter	Type	Bush	Bore		F	E	L	M	Weight	Designation
				Min	Max						
Inch	Inch			Inch	Inch	Inch	Inch	Inch	Inch	lbs	
7,10	7,00	A-1	3030	1 1/4	3	5 13/16	1	3	1 13/16	24	PHP 8-5V710TB
7,50	7,40	A-1	3030	1 1/4	3	5 13/16	1	3	1 13/16	28	PHP 8-5V750TB
8,00	7,90	A-1	3030	1 1/4	3	5 13/16	1	3	1 13/16	33	PHP 8-5V800TB
8,50	8,40	A-1	3030	1 1/4	3	5 13/16	1	3	1 13/16	38	PHP 8-5V850TB
9,00	8,90	A-1	3535	2	3 15/16	5 13/16	1	3 1/2	1 7/16	44	PHP 8-5V900TB
9,25	9,15	A-1	3535	2	3 15/16	5 13/16	1	3 1/2	1 7/16	45	PHP 8-5V925TB
9,75	9,65	A-1	3535	2	3 15/16	5 13/16	1	3 1/2	1 7/16	51	PHP 8-5V975TB
10,30	10,20	A-1	3535	2	3 15/16	5 13/16	1	3 1/2	1 7/16	60	PHP 8-5V1030TB
10,90	10,80	A-1	3535	2	3 15/16	5 13/16	1	3 1/2	1 7/16	68	PHP 8-5V1090TB
11,80	11,70	A-2	3535	2	3 15/16	5 13/16	1	3 1/2	1 7/16	63	PHP 8-5V1180TB
12,50	12,40	A-2	4040	1 3/4	4 7/16	5 13/16	1/4	4	1 7/16	82	PHP 8-5V1250TB
13,20	13,10	A-2	4040	1 3/4	4 7/16	5 13/16	1/4	4	1 7/16	82	PHP 8-5V1320TB
14,00	13,90	A-2	4040	1 3/4	4 7/16	5 13/16	1/4	4	1 7/16	87	PHP 8-5V1400TB
15,00	14,90	A-2	4040	1 3/4	4 7/16	5 13/16	1/4	4	1 7/16	97	PHP 8-5V1500TB
16,00	15,90	A-2	4040	1 3/4	4 7/16	5 13/16	1/4	4	1 7/16	102	PHP 8-5V1600TB
21,20	21,10	A-3	4040	1 3/4	4 7/16	5 13/16	1/4	4	1 7/16	122	PHP 8-5V2120TB
28,00	27,90	A-3	4545	2 1/4	4 15/16	5 13/16	1/4	4 1/2	1 7/16	176	PHP 8-5V2800TB
37,50	37,40	A-3	4545	2 1/4	4 15/16	5 13/16	1/4	4 1/2	1 7/16	271	PHP 8-5V3750TB
50,00	49,90	A-3	4545	2 1/4	4 15/16	5 13/16	1/4	4 1/2	1 7/16	356	PHP 8-5V5000TB

Type C-2

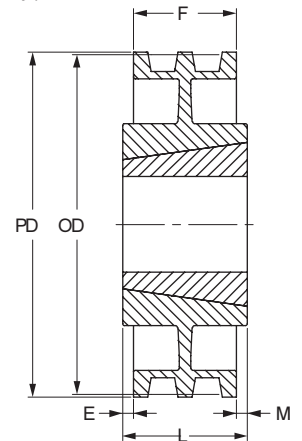

10 Groove

Outside Diameter	Pitch Diameter	Type	Bush	Bore		F	E	L	M	Weight	Designation
				Min	Max						
Inch	Inch			Inch	Inch	Inch	Inch	Inch	Inch	lbs	
8,00	7,90	A-1	3030	1 1/4	3	7 3/16	1	3	3 3/16	36	PHP 10-5V800TB
8,50	8,40	A-1	3030	1 1/4	3	7 3/16	1	3	3 3/16	42	PHP 10-5V850TB
9,00	8,90	A-1	3535	2	3 15/16	7 3/16	1	3 1/2	2 11/16	47	PHP 10-5V900TB
9,25	9,15	A-1	4040	1 3/4	4 7/16	7 3/16	1	4	2 1/6	46	PHP 10-5V925TB
9,75	9,65	A-1	4040	1 3/4	4 7/16	7 3/16	1	4	2 1/6	54	PHP 10-5V975TB
10,30	10,20	A-1	4040	1 3/4	4 7/16	7 3/16	1	4	2 1/6	64	PHP 10-5V1030TB
10,90	10,80	A-1	4040	1 3/4	4 7/16	7 3/16	1	4	2 1/6	73	PHP 10-5V1090TB
11,30	11,20	A-1	4040	1 3/4	4 7/16	7 3/16	1	4	2 1/6	92	PHP 10-5V1130TB
11,80	11,70	A-1	4040	1 3/4	4 7/16	7 3/16	1	4	2 1/6	87	PHP 10-5V1180TB
12,50	12,40	A-2	4040	1 3/4	4 7/16	7 3/16	3/4	4	2 1/6	87	PHP 10-5V1250TB
13,20	13,10	A-2	4040	1 3/4	4 7/16	7 3/16	3/4	4	2 1/6	106	PHP 10-5V1320TB
14,00	13,90	A-2	4545	2 1/4	4 7/16	7 3/16	3/4	4 1/2	2 1/6	116	PHP 10-5V1400TB
15,00	14,90	A-2	4545	2 1/4	4 7/16	7 3/16	3/4	4 1/2	1 15/16	126	PHP 10-5V1500TB
16,00	15,90	A-2	4545	2 1/4	4 7/16	7 3/16	3/4	4 1/2	1 15/16	131	PHP 10-5V1600TB
18,70	18,60	A-2	4545	2 1/4	4 7/16	7 3/16	3/4	4 1/2	1 15/16	136	PHP 10-5V1870TB
21,20	21,10	A-3	4545	2 1/4	4 7/16	7 3/16	3/4	4 1/2	1 15/16	139	PHP 10-5V2120TB
28,00	27,90	A-3	4545	2 1/4	4 7/16	7 3/16	3/4	4 1/2	1 15/16	191	PHP 10-5V2800TB
37,50	37,40	A-3	4545	2 1/4	4 7/16	7 3/16	3/4	4 1/2	1 15/16	316	PHP 10-5V3750TB
50,00	49,90	A-3	5050	2 3/4	5	7 3/16	3/4	5	1 7/16	428	PHP 10-5V5000TB

Type C-3

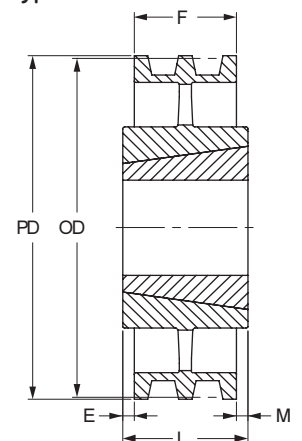



Narrow wedge belt pulleys

8V taper bushed



Type A-1

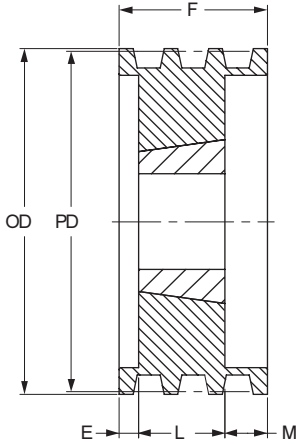

Type A-2

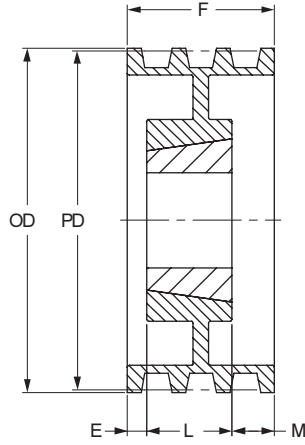

Type A-3

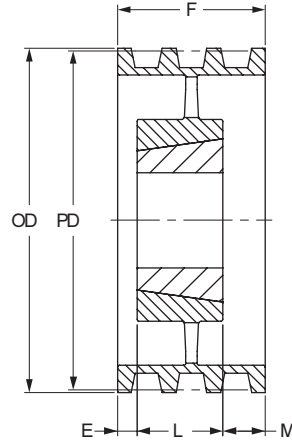

Type C-3

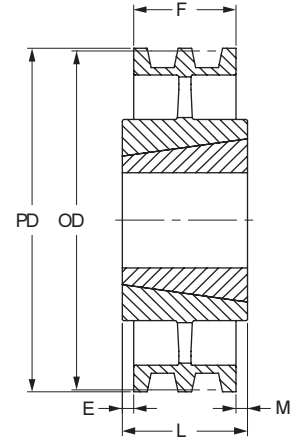

4 Groove

Outside Diameter	Pitch Diameter	Type	Bush	Bore		F	E	L	M	Weight	Designation
				Min	Max						
Inch	Inch			Inch	Inch	Inch	Inch	Inch	Inch	lbs	
12,5	12,3	A-1	4040	1 3/4	4 7/16	4 7/8	0	4	7/8	92	PHP 4-8V1250TB
13,2	13,0	A-1	4040	1 3/4	4 7/16	4 7/8	0	4	7/8	107	PHP 4-8V1320TB
14,0	13,8	A-1	4040	1 3/4	4 15/16	4 7/8	0	4 1/2	3/8	126	PHP 4-8V1400TB
15,0	14,8	A-1	4040	1 3/4	4 15/16	4 7/8	0	4 1/2	3/8	116	PHP 4-8V1500TB
16,0	15,8	A-2	4040	1 3/4	4 15/16	4 7/8	0	4 1/2	3/8	126	PHP 4-8V1600TB
17,0	16,8	A-2	4040	1 3/4	4 15/16	4 7/8	0	4 1/2	3/8	136	PHP 4-8V1700TB
18,0	17,8	A-2	4040	1 3/4	4 15/16	4 7/8	0	4 1/2	3/8	146	PHP 4-8V1800TB
19,0	18,8	A-2	4040	1 3/4	4 15/16	4 7/8	0	4 1/2	3/8	161	PHP 4-8V1900TB
20,0	19,8	A-2	4545	2 1/4	4 15/16	4 7/8	0	4 1/2	3/8	171	PHP 4-8V2000TB
21,2	21,0	A-3	4545	2 1/4	4 15/16	4 7/8	0	4 1/2	3/8	146	PHP 4-8V2120TB
22,4	22,2	A-3	4545	2 1/4	4 15/16	4 7/8	0	4 1/2	3/8	161	PHP 4-8V2240TB
30,0	29,8	A-3	4545	2 1/4	4 15/16	4 7/8	0	4 1/2	3/8	251	PHP 4-8V3000TB
35,5	35,3	A-3	4545	2 1/4	4 15/16	4 7/8	0	4 1/2	3/8	285	PHP 4-8V3550TB
40,0	39,8	C-3	5050	2 3/4	5	4 7/8	0	5	1/8	316	PHP 4-8V4000TB
44,5	44,3	C-3	5050	2 3/4	5	4 7/8	0	5	1/8	408	PHP 4-8V4450TB
53,0	52,8	C-3	5050	2 3/4	5	4 7/8	0	5	1/8	476	PHP 4-8V5300TB

5 Groove

Outside Diameter	Pitch Diameter	Type	Bush	Bore		F	E	L	M	Weight	Designation
				Min	Max						
Inch	Inch			Inch	Inch	Inch	Inch	Inch	Inch	lbs	
12,5	12,3	A-1	4040	1 3/4	4 15/16	6	0	4 1/2	1 1/2	96	PHP 5-8V1250TB
13,2	13,0	A-1	4040	1 3/4	4 15/16	6	0	4 1/2	1 1/2	116	PHP 5-8V1320TB
14,0	13,8	A-1	4040	1 3/4	4 15/16	6	0	4 1/2	1 1/2	136	PHP 5-8V1400TB
15,0	14,8	A-1	4040	1 3/4	4 15/16	6	0	4 1/2	1 1/2	131	PHP 5-8V1500TB
16,0	15,8	A-1	4040	1 3/4	4 15/16	6	0	4 1/2	1 1/2	141	PHP 5-8V1600TB
17,0	16,8	A-2	4040	1 3/4	4 15/16	6	0	4 1/2	1 1/2	146	PHP 5-8V1700TB
18,0	17,8	A-2	4040	1 3/4	4 15/16	6	0	4 1/2	1 1/2	156	PHP 5-8V1800TB
19,0	18,8	A-2	4040	1 3/4	4 15/16	6	0	4 1/2	1 1/2	176	PHP 5-8V1900TB
20,0	19,8	A-2	4545	2 1/4	4 15/16	6	0	4 1/2	1 1/2	186	PHP 5-8V2000TB
21,2	21,0	A-3	4545	2 1/4	4 15/16	6	0	4 1/2	1 1/2	161	PHP 5-8V2120TB
22,4	22,2	A-3	4545	2 1/4	4 15/16	6	0	4 1/2	1 1/2	176	PHP 5-8V2240TB
24,8	24,6	A-3	4545	2 1/4	4 15/16	6	0	4 1/2	1 1/2	235	PHP 5-8V2480TB
30,0	29,8	A-3	4545	2 1/4	4 15/16	6	0	4 1/2	1 1/2	271	PHP 5-8V3000TB
35,5	35,3	A-3	4545	2 1/4	4 15/16	6	0	4 1/2	1 1/2	325	PHP 5-8V3550TB
40,0	39,8	A-3	5050	2 3/4	5	6	0	5	1	350	PHP 5-8V4000TB
44,5	44,3	A-3	5050	2 3/4	5	6	0	5	1	411	PHP 5-8V4450TB
53,0	52,8	A-3	5050	2 3/4	5	6	0	5	1	565	PHP 5-8V5300TB



Narrow wedge belt pulleys

8V taper bushed

- ▶ Belts
- ▶ Chains
- ▶ Couplings
- ▶ Bushings and Hubs
- ▶ Sprockets
- ▶ Pulleys
- ▶ Smart tools

6 Groove

Outside Diameter	Pitch Diameter	Type	Bush	Bore		F	E	L	M	Weight	Designation
				Min	Max						
Inch	Inch			Inch	Inch	Inch	Inch	Inch	Inch	lbs	
12,5	12,3	A-1	4545	2 1/4	4 15/16	6 1/8	1/2	4 1/2	2 1/8	105	PHP 6-8V1250TB
13,2	13,0	A-1	4545	2 1/4	4 15/16	6 1/8	1/2	4 1/2	2 1/8	125	PHP 6-8V1320TB
14,0	13,8	A-1	4545	2 1/4	4 15/16	6 1/8	1/2	4 1/2	2 1/8	145	PHP 6-8V1400TB
15,0	14,8	A-1	4545	2 1/4	4 15/16	6 1/8	1/2	4 1/2	2 1/8	170	PHP 6-8V1500TB
16,0	15,8	A-2	4545	2 1/4	4 15/16	6 1/8	1/2	4 1/2	2 1/8	145	PHP 6-8V1600TB
17,0	16,8	A-2	4545	2 1/4	4 15/16	6 1/8	1/2	4 1/2	2 1/8	150	PHP 6-8V1700TB
18,0	17,8	A-2	4545	2 1/4	4 15/16	6 1/8	1/2	4 1/2	2 1/8	160	PHP 6-8V1800TB
19,0	18,8	A-2	4545	2 1/4	4 15/16	6 1/8	1/2	4 1/2	2 1/8	185	PHP 6-8V1900TB
20,0	19,8	A-2	4545	2 1/4	4 15/16	6 1/8	1/2	4 1/2	2 1/8	200	PHP 6-8V2000TB
21,2	21,0	A-3	4545	2 1/4	4 15/16	6 1/8	1/2	4 1/2	2 1/8	170	PHP 6-8V2120TB
22,4	22,2	A-3	4545	2 1/4	4 15/16	6 1/8	1/2	4 1/2	2 1/8	180	PHP 6-8V2240TB
24,8	24,6	A-3	4545	2 1/4	4 15/16	6 1/8	1/2	4 1/2	2 1/8	238	PHP 6-8V2480TB
30,0	29,8	A-3	5050	2 3/4	5	6 1/8	1/2	5	1 1/8	285	PHP 6-8V3000TB
35,5	35,3	A-3	5050	2 3/4	5	6 1/8	1/2	5	1 1/8	336	PHP 6-8V3550TB
40,0	39,8	A-3	5050	2 3/4	5	6 1/8	1/2	5	1 1/8	375	PHP 6-8V4000TB
44,5	44,3	A-3	5050	2 3/4	5	6 1/8	1/2	5	1 1/8	436	PHP 6-8V4450TB
53,0	52,8	A-3	5050	2 3/4	5	6 1/8	1/2	5	1 1/8	595	PHP 6-8V5300TB

Type A-1

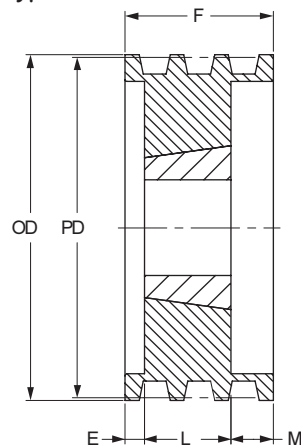

8 Groove

Outside Diameter	Pitch Diameter	Type	Bush	Bore		F	E	L	M	Weight	Designation
				Min	Max						
Inch	Inch			Inch	Inch	Inch	Inch	Inch	Inch	lbs	
12,5	12,3	A-1	4545	2 1/4	4 15/16	9 3/8	1 1/2	4 1/2	3 3/8	125	PHP 8-8V1250TB
13,2	13,0	A-1	4545	2 1/4	4 15/16	9 3/8	1 1/2	4 1/2	3 3/8	135	PHP 8-8V1320TB
14,0	13,8	A-1	4545	2 1/4	4 15/16	9 3/8	1 1/2	4 1/2	3 3/8	155	PHP 8-8V1400TB
15,0	14,8	A-1	4545	2 1/4	4 15/16	9 3/8	1 1/2	4 1/2	3 3/8	180	PHP 8-8V1500TB
16,0	15,8	A-1	4545	2 1/4	4 15/16	9 3/8	1 1/2	4 1/2	3 3/8	160	PHP 8-8V1600TB
17,0	16,8	A-2	5050	2 3/4	5	9 3/8	1 1/2	5	3 3/8	176	PHP 8-8V1700TB
18,0	17,8	A-2	5050	2 3/4	5	9 3/8	1	5	3 3/8	190	PHP 8-8V1800TB
19,0	18,8	A-2	5050	2 3/4	5	9 3/8	1	5	3 3/8	210	PHP 8-8V1900TB
20,0	19,8	A-2	5050	2 3/4	5	9 3/8	1	5	3 3/8	225	PHP 8-8V2000TB
21,2	21,0	A-2	5050	2 3/4	5	9 3/8	1	5	3 3/8	245	PHP 8-8V2120TB
22,4	22,2	A-3	5050	2 3/4	5	9 3/8	1	5	3 3/8	300	PHP 8-8V2240TB
24,8	24,6	A-3	5050	2 3/4	5	9 3/8	1	5	3 3/8	309	PHP 8-8V2480TB
30,0	29,8	A-3	5050	2 3/4	5	9 3/8	1	5	3 3/8	315	PHP 8-8V3000TB
35,5	35,3	A-3	5050	2 3/4	5	9 3/8	1	5	3 3/8	415	PHP 8-8V3550TB
40,0	39,8	A-3	5050	2 3/4	5	9 3/8	1	5	3 3/8	470	PHP 8-8V4000TB
44,5	44,3	A-3	5050	2 3/4	5	9 3/8	1	5	3 3/8	585	PHP 8-8V4450TB
53,0	52,8	A-3	6050	2 3/4	5	9 3/8	1	5	3 3/8	700	PHP 8-8V5300TB

Type A-2

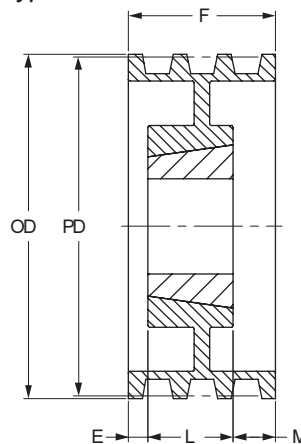

10 Groove

Outside Diameter	Pitch Diameter	Type	Bush	Bore		F	E	L	M	Weight	Designation
				Min	Max						
Inch	Inch			Inch	Inch	Inch	Inch	Inch	Inch	lbs	
13,2	13,0	A-1	4545	2 1/4	4 15/16	11 5/8	1	4 1/2	6 1/8	150	PHP 10-8V1320TB
14,0	13,8	A-1	4545	2 1/4	4 15/16	11 5/8	1	4 1/2	6 1/8	175	PHP 10-8V1400TB
15,0	14,8	A-1	5050	2 3/4	5	11 5/8	1	5	5 3/8	175	PHP 10-8V1500TB
16,0	15,8	A-1	5050	2 3/4	5	11 5/8	1	5	5 3/8	220	PHP 10-8V1600TB
17,0	16,8	A-2	5050	2 3/4	5	11 5/8	2 1/4	5	4 3/8	185	PHP 10-8V1700TB
18,0	17,8	A-2	5050	2 3/4	5	11 5/8	2 1/4	5	4 3/8	220	PHP 10-8V1800TB
19,0	18,8	A-2	5050	2 3/4	5	11 5/8	2 1/4	5	4 3/8	240	PHP 10-8V1900TB
20,0	19,8	A-2	5050	2 3/4	5	11 5/8	2 1/4	5	4 3/8	260	PHP 10-8V2000TB
21,2	21,0	A-2	5050	2 3/4	5	11 5/8	2 1/4	5	4 3/8	280	PHP 10-8V2120TB
22,4	22,2	A-3	5050	2 3/4	5	11 5/8	2 1/4	5	4 3/8	335	PHP 10-8V2240TB
24,8	24,6	A-3	5050	2 3/4	5	11 5/8	2 1/4	5	4 3/8	358	PHP 10-8V2480TB
30,0	29,8	A-3	5050	2 3/4	5	11 5/8	2 1/4	5	4 3/8	370	PHP 10-8V3000TB
35,5	35,3	A-3	5050	2 3/4	5	11 5/8	2 1/4	5	4 3/8	480	PHP 10-8V3550TB
40,0	39,8	A-3	5050	2 3/4	5	11 5/8	2 1/4	5	4 3/8	550	PHP 10-8V4000TB
44,5	44,3	A-3	6050	2 3/4	5	11 5/8	2 1/4	5	4 3/8	675	PHP 10-8V4450TB
53,0	52,8	A-3	6050	2 3/4	5	11 5/8	2 1/4	5	4 3/8	870	PHP 10-8V5300TB

Type A-3

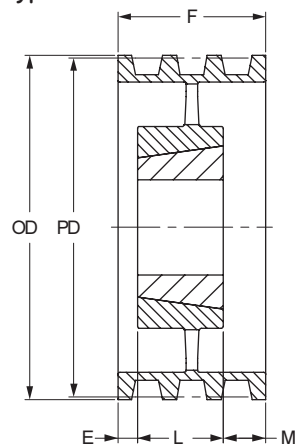



HiTD pulleys

Pilot bore (RSB)



3 mm Pitch

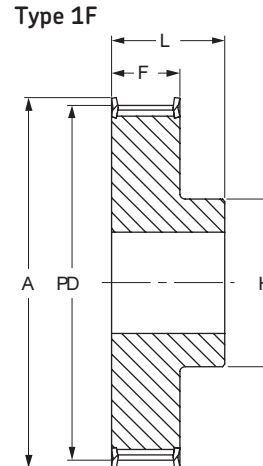
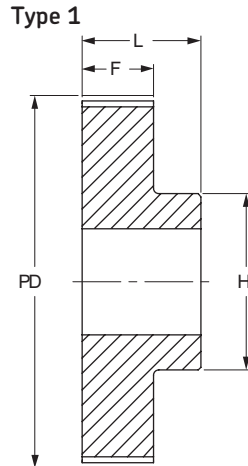
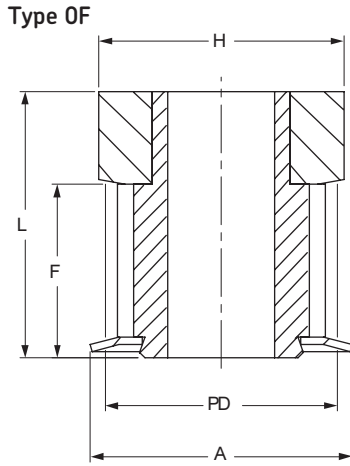

Belt Width 09 mm

No. Teeth	Diameter			Type	Bore		Dimensions					Weight	Designation
	P.D.	O.D.	A		Min	Max	F	K	L	M	H		
	mm	mm	mm		mm	mm	mm	mm	mm	mm	mm		
10	9,55	8,79	13,0	0F	-	4,0	10,2	-	17,5	-	13,0	0,04	PHP 10-3M-09RSB
12	11,46	10,70	15,0	0F	-	6,0	10,2	-	17,5	-	15,0	0,06	PHP 12-3M-09RSB
14	13,37	12,61	16,0	0F	-	7,0	10,2	-	17,5	-	16,0	0,07	PHP 14-3M-09RSB
15	14,32	13,56	17,5	0F	-	8,0	10,2	-	17,5	-	17,5	0,08	PHP 15-3M-09RSB
16	15,28	14,52	18,0	1F	4	6,0	12,8	-	20,6	-	10,0	0,07	PHP 16-3M-09RSB
18	17,19	16,43	19,5	1F	6	6,5	12,8	-	20,6	-	11,0	0,08	PHP 18-3M-09RSB
20	19,10	18,34	23,0	1F	6	8,0	12,8	-	20,6	-	13,0	0,01	PHP 20-3M-09RSB
21	20,05	19,29	25,0	1F	6	8,5	12,8	-	20,6	-	14,0	0,01	PHP 21-3M-09RSB
22	21,01	20,25	25,0	1F	6	8,5	12,8	-	20,6	-	14,0	0,01	PHP 22-3M-09RSB
24	22,92	22,16	25,0	1F	6	8,5	12,8	-	20,6	-	14,0	0,02	PHP 24-3M-09RSB
26	24,83	24,07	28,0	1F	6	10,5	12,8	-	20,6	-	16,0	0,02	PHP 26-3M-09RSB
28	26,74	25,98	32,0	1F	6	11,5	12,8	-	20,6	-	18,0	0,02	PHP 28-3M-09RSB
30	28,65	27,89	32,0	1F	6	12,5	12,8	-	20,6	-	20,0	0,03	PHP 30-3M-09RSB
32	30,56	29,80	36,0	1F	6	14,0	12,8	-	20,6	-	22,0	0,03	PHP 32-3M-09RSB
36	34,38	33,62	38,0	1F	6	17,0	13,4	-	22,2	-	26,0	0,05	PHP 36-3M-09RSB
40	38,20	37,44	42,0	1F	6	19,0	13,4	-	22,2	-	28,0	0,06	PHP 40-3M-09RSB
44	42,02	41,26	48,0	1F	6	22,5	13,4	-	22,2	-	33,0	0,07	PHP 44-3M-09RSB
48	45,84	45,08	-	1	8	22,5	13,4	-	22,2	-	33,0	0,07	PHP 48-3M-09RSB
60	57,30	56,54	-	1	8	22,5	13,4	-	22,2	-	33,0	0,11	PHP 60-3M-09RSB
72	68,75	67,99	-	1	8	22,5	13,4	-	22,2	-	33,0	0,14	PHP 72-3M-09RSB

Belt Width 15 mm

No. Teeth	Diameter			Type	Bore		Dimensions					Weight	Designation
	P.D.	O.D.	A		Min	Max	F	K	L	M	H		
	mm	mm	mm		mm	mm	mm	mm	mm	mm	mm		
10	9,55	8,79	13	0F	-	3	17,0	-	26,0	-	13,0	0,04	PHP 10-3M-15RSB
12	11,46	10,70	15	0F	-	5	17,0	-	26,0	-	15,0	0,06	PHP 12-3M-15RSB
14	13,37	12,61	16	0F	-	6	17,0	-	26,0	-	16,0	0,07	PHP 14-3M-15RSB
15	14,32	13,56	17,5	0F	-	6	17,0	-	26,0	-	17,5	0,08	PHP 15-3M-15RSB
16	15,28	14,52	18	1F	4	7	19,5	-	26,0	-	10,0	0,07	PHP 16-3M-15RSB
18	17,19	16,43	19,5	1F	6	8	19,5	-	26,0	-	11,0	0,08	PHP 18-3M-15RSB
20	19,10	18,34	23	1F	6	9	19,5	-	26,0	-	13,0	0,01	PHP 20-3M-15RSB
21	20,05	19,29	25	1F	6	9	19,5	-	26,0	-	14,0	0,01	PHP 21-3M-15RSB
22	21,01	20,25	25	1F	6	9	19,5	-	26,0	-	14,0	0,01	PHP 22-3M-15RSB
24	22,92	22,16	25	1F	6	9	19,5	-	26,0	-	14,0	0,02	PHP 24-3M-15RSB
26	24,83	24,07	28	1F	6	11	19,5	-	26,0	-	16,0	0,02	PHP 26-3M-15RSB
28	26,74	25,98	32	1F	6	12	19,5	-	26,0	-	18,0	0,02	PHP 28-3M-15RSB
30	28,65	27,89	32	1F	6	14	19,5	-	26,0	-	20,0	0,03	PHP 30-3M-15RSB
32	30,56	29,80	36	1F	6	15	19,5	-	26,0	-	22,0	0,03	PHP 32-3M-15RSB
36	34,38	33,62	38	1F	6	16	20,0	-	30,0	-	26,0	0,05	PHP 36-3M-15RSB
40	38,20	37,44	42	1F	6	18	20,0	-	30,0	-	28,0	0,06	PHP 40-3M-15RSB
44	42,02	41,26	48	1F	6	20	20,0	-	30,0	-	33,0	0,07	PHP 44-3M-15RSB
48	45,84	45,08	-	1	8	20	20,0	-	30,0	-	33,0	0,07	PHP 48-3M-15RSB
60	57,30	56,54	-	1	8	20	20,0	-	30,0	-	33,0	0,11	PHP 60-3M-15RSB
72	68,75	67,99	-	1	8	20	20,0	-	30,0	-	33,0	0,14	PHP 72-3M-15RSB



HiTD pulleys

Pilot bore (RSB)

- ▶ Belts
- ▶ Chains
- ▶ Couplings
- ▶ Bushings and Hubs
- ▶ Sprockets
- ▶ Pulleys
- ▶ Smart tools

5 mm Pitch

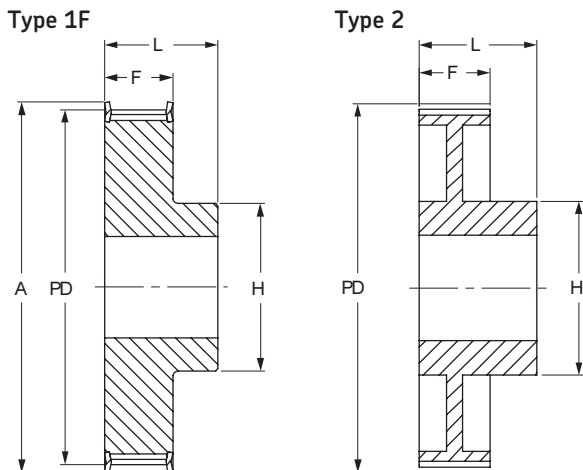

Belt Width 09 mm

No. Teeth	Diameter			Type	Bore		Dimensions					Weight	Designation
	P.D.	O.D.	A		Min	Max	F	K	L	M	H		
	mm	mm	mm		mm	mm	mm	mm	mm	mm	mm		
12	19,10	17,96	25	1F	4	8	14,5	-	20,0	-	13,0	0,03	PHP 12-5M-09RSB
14	22,28	21,14	25	1F	6	9	14,5	-	20,0	-	13,0	0,03	PHP 14-5M-09RSB
15	23,87	22,73	28	1F	6	11	14,5	-	20,0	-	16,0	0,04	PHP 15-5M-09RSB
16	25,46	24,32	28	1F	6	11	14,5	-	20,0	-	16,0	0,05	PHP 16-5M-09RSB
18	28,65	27,51	32	1F	6	13	14,5	-	20,0	-	19,0	0,07	PHP 18-5M-09RSB
20	31,83	30,69	36	1F	6	14	14,5	-	22,5	-	23,0	0,09	PHP 20-5M-09RSB
21	33,42	32,28	38	1F	6	15	14,5	-	22,5	-	24,0	0,11	PHP 21-5M-09RSB
22	35,01	33,87	38	1F	6	16	14,5	-	22,5	-	25,5	0,12	PHP 22-5M-09RSB
24	38,20	37,06	42	1F	6	18	14,5	-	22,5	-	27,0	0,15	PHP 24-5M-09RSB
26	41,38	40,24	44	1F	6	20	14,5	-	22,5	-	30,0	0,17	PHP 26-5M-09RSB
28	44,56	43,42	48	1F	6	20	14,5	-	22,5	-	30,5	0,20	PHP 28-5M-09RSB
30	47,75	46,60	51	1F	6	24	14,5	-	22,5	-	35,0	0,24	PHP 30-5M-09RSB
32	50,93	49,79	54	1F	8	26	14,5	-	22,5	-	38,0	0,27	PHP 32-5M-09RSB
36	57,30	56,16	60	1F	8	26	14,5	-	22,5	-	38,0	0,32	PHP 36-5M-09RSB
40	63,66	62,52	71	1F	8	26	14,5	-	22,5	-	38,0	0,40	PHP 40-5M-09RSB
44	70,03	68,89	-	2	8	26	14,5	-	25,5	-	38,0	0,17	PHP 44-5M-09RSB
48	76,39	75,25	-	2	8	26	14,5	-	25,5	-	38,0	0,18	PHP 48-5M-09RSB
60	95,49	94,35	-	2	8	30	14,5	-	25,5	-	45,0	0,23	PHP 60-5M-09RSB
72	114,59	113,45	-	2	8	30	14,5	-	25,5	-	45,0	0,27	PHP 72-5M-09RSB

Belt Width 15 mm

No. Teeth	Diameter			Type	Bore		Dimensions					Weight	Designation
	P.D.	O.D.	A		Min	Max	F	K	L	M	H		
	mm	mm	mm		mm	mm	mm	mm	mm	mm	mm		
12	19,10	17,96	25	1F	4	8	20,5	-	26,0	-	13,0	0,03	PHP 12-5M-15RSB
14	22,28	21,14	25	1F	6	9	20,5	-	26,0	-	13,0	0,05	PHP 14-5M-15RSB
15	23,87	22,73	28	1F	6	11	20,5	-	26,0	-	16,0	0,06	PHP 15-5M-15RSB
16	25,46	24,32	28	1F	6	11	20,5	-	26,0	-	16,0	0,06	PHP 16-5M-15RSB
18	28,65	27,51	32	1F	6	13	20,5	-	26,0	-	19,0	0,09	PHP 18-5M-15RSB
20	31,83	30,69	36	1F	6	14	20,5	-	26,0	-	23,0	0,11	PHP 20-5M-15RSB
21	33,42	32,28	38	1F	6	15	20,5	-	26,0	-	24,0	0,13	PHP 21-5M-15RSB
22	35,01	33,87	38	1F	6	16	20,5	-	26,0	-	25,5	0,14	PHP 22-5M-15RSB
24	38,20	37,06	42	1F	6	18	20,5	-	28,0	-	27,0	0,18	PHP 24-5M-15RSB
26	41,38	40,24	44	1F	6	20	20,5	-	28,0	-	30,0	0,22	PHP 26-5M-15RSB
28	44,56	43,42	48	1F	6	20	20,5	-	28,0	-	30,5	0,25	PHP 28-5M-15RSB
30	47,75	46,60	51	1F	6	24	20,5	-	28,0	-	35,0	0,30	PHP 30-5M-15RSB
32	50,93	49,79	54	1F	8	26	20,5	-	28,0	-	38,0	0,35	PHP 32-5M-15RSB
36	57,30	56,16	60	1F	8	26	20,5	-	28,0	-	38,0	0,52	PHP 36-5M-15RSB
40	63,66	62,52	71	1F	8	26	20,5	-	28,0	-	38,0	0,43	PHP 40-5M-15RSB
44	70,03	68,89	-	2	8	26	20,5	-	30,0	-	38,0	0,23	PHP 44-5M-15RSB
48	76,39	75,25	-	2	8	26	20,5	-	30,0	-	38,0	0,19	PHP 48-5M-15RSB
60	95,49	94,35	-	2	8	34	20,5	-	30,0	-	50,0	0,31	PHP 60-5M-15RSB
72	114,59	113,45	-	2	8	34	20,5	-	30,0	-	50,0	0,38	PHP 72-5M-15RSB



HiTD pulleys

Pilot bore (RSB)



5 mm Pitch

Type 1F

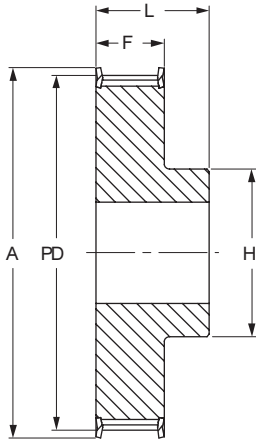

Type 1

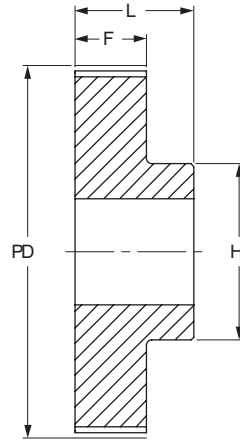

Type 2

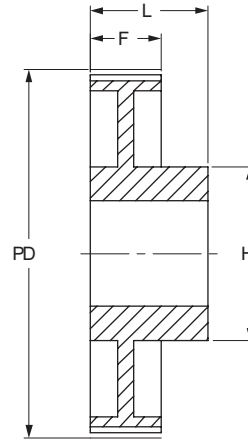

Belt Width 25 mm

No. Teeth	Diameter			Type	Bore		Dimensions					Weight	Designation
	P.D.	O.D.	A		Min	Max	F	K	L	M	H		
	mm	mm	mm		mm	mm	mm	mm	mm	mm	mm	mm	
12	19,10	17,96	25	1F	4	8	30,5	-	36	5,5	13,0	0,05	PHP 12-5M-25RSB
14	22,28	21,14	25	1F	6	9	30,5	-	36	5,5	13,0	0,07	PHP 14-5M-25RSB
15	23,87	22,73	28	1F	6	11	30,5	-	36	5,5	16,0	0,08	PHP 15-5M-25RSB
16	25,46	24,32	28	1F	6	11	30,5	-	36	5,5	16,0	0,10	PHP 16-5M-25RSB
18	28,65	27,51	32	1F	6	13	30,5	-	36	5,5	19,0	0,12	PHP 18-5M-25RSB
20	31,83	30,69	36	1F	6	14	30,5	-	36	5,5	23,0	0,16	PHP 20-5M-25RSB
21	33,42	32,28	38	1F	6	15	30,5	-	38	7,5	24,0	0,19	PHP 21-5M-25RSB
22	35,01	33,87	38	1F	6	16	30,5	-	38	7,5	25,5	0,21	PHP 22-5M-25RSB
24	38,20	37,06	42	1F	6	18	30,5	-	38	7,5	27,0	0,25	PHP 24-5M-25RSB
26	41,38	40,24	44	1F	6	20	30,5	-	38	7,5	30,0	0,30	PHP 26-5M-25RSB
28	44,56	43,42	48	1F	6	20	30,5	-	38	7,5	30,5	0,35	PHP 28-5M-25RSB
30	47,75	46,60	51	1F	6	24	30,5	-	38	7,5	35,0	0,42	PHP 30-5M-25RSB
32	50,93	49,79	54	1F	8	26	30,5	-	38	7,5	38,0	0,48	PHP 32-5M-25RSB
36	57,30	56,16	60	1F	8	26	30,5	-	38	7,5	38,0	0,59	PHP 36-5M-25RSB
40	63,66	62,52	71	1F	8	26	30,5	-	38	7,5	38,0	0,74	PHP 40-5M-25RSB
44	70,03	68,89	-	2	8	26	30,5	-	40	9,5	38,0	0,32	PHP 44-5M-25RSB
48	76,39	72,25	-	2	8	26	30,5	-	40	9,5	38,0	0,28	PHP 48-5M-25RSB
60	95,49	94,35	-	2	8	34	30,5	-	40	9,5	50,0	0,44	PHP 60-5M-25RSB
72	114,59	113,45	-	2	8	34	30,5	-	40	9,5	50,0	0,53	PHP 72-5M-25RSB
80	127,32	126,18	-	1	8	62	30,5	-	40	-	92,0	0,60	PHP 80-5M-25RSB



HiTD pulleys

Pilot bore (RSB)

- ▶ Belts
- ▶ Chains
- ▶ Couplings
- ▶ Bushings and Hubs
- ▶ Sprockets
- ▶ Pulleys
- ▶ Smart tools

8 mm Pitch

Type 1F

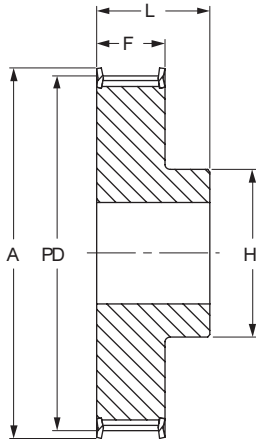

Type 2

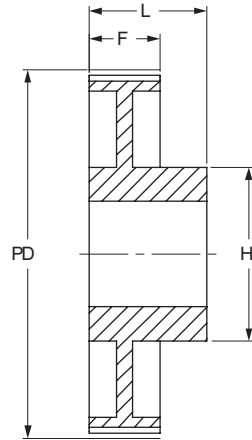

Type 2F

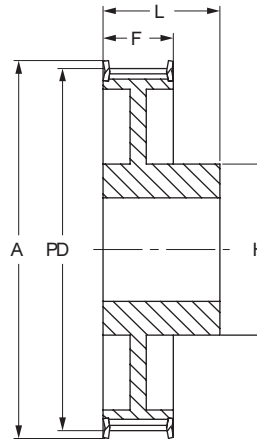

Type 5

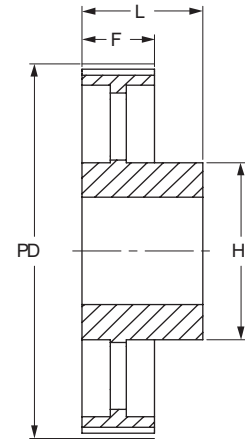

Belt Width 20 mm

No. Teeth	Diameter			Type	Bore		Dimensions					Weight kg	Designation
	P.D.	O.D.	A		Min	Max	F	K	L	M	H		
	mm	mm	mm		mm	mm	mm	mm	mm	mm	mm		
20	50,93	49,56	60	1F	12	25	28,0	-	38	-	38,0	0,43	PHP 20-8M-20RSB
21	53,47	52,10	62	1F	12	27	28,0	-	38	-	40,0	0,49	PHP 21-8M-20RSB
22	56,02	54,65	65	1F	12	29	28,0	-	38	-	43,0	0,54	PHP 22-8M-20RSB
23	58,57	57,20	65	1F	12	29	28,0	-	38	-	45,0	0,60	PHP 23-8M-20RSB
24	61,12	59,75	70	1F	12	30	28,0	-	38	-	45,0	0,65	PHP 24-8M-20RSB
25	63,66	62,28	71	1F	12	31	28,0	-	38	-	45,0	0,73	PHP 25-8M-20RSB
26	66,21	64,84	75	1F	12	32	28,0	-	38	-	50,0	0,80	PHP 26-8M-20RSB
27	68,75	67,39	75	1F	12	33	28,0	-	38	-	50,0	0,84	PHP 27-8M-20RSB
28	71,30	70,08	80	1F	15	34	28,0	-	38	-	50,0	0,87	PHP 28-8M-20RSB
29	73,85	72,62	85	1F	15	35	28,0	-	38	-	55,0	0,95	PHP 29-8M-20RSB
30	76,39	75,13	85	1F	15	36	28,0	-	38	-	55,0	1,02	PHP 30-8M-20RSB
31	78,94	77,65	87	1F	15	38	28,0	-	38	-	55,0	1,11	PHP 31-8M-20RSB
32	81,49	80,16	90	1F	15	40	28,0	-	38	-	60,0	1,20	PHP 32-8M-20RSB
33	84,03	82,68	90	1F	15	42	28,0	-	38	-	60,0	1,30	PHP 33-8M-20RSB
34	86,58	85,22	95	1F	15	44	28,0	-	38	-	70,0	1,40	PHP 34-8M-20RSB
35	89,13	87,76	95	1F	15	45	28,0	-	38	-	70,0	1,48	PHP 35-8M-20RSB
36	91,67	90,30	100	1F	15	46	28,0	-	38	-	70,0	1,55	PHP 36-8M-20RSB
38	96,77	95,39	105	1F	15	50	28,0	-	38	-	75,0	1,65	PHP 38-8M-20RSB
40	101,86	100,49	110	1F	15	50	28,0	-	38	-	75,0	1,74	PHP 40-8M-20RSB
42	106,95	105,58	111	1F	15	50	28,0	-	38	-	75,0	1,92	PHP 42-8M-20RSB
44	112,05	110,67	121	1F	15	50	28,0	-	38	-	75,0	2,10	PHP 44-8M-20RSB
45	114,59	113,22	121	1F	15	50	28,0	-	38	-	75,0	2,19	PHP 45-8M-20RSB
48	122,23	120,86	131	1F	15	54	28,0	-	38	-	75,0	2,44	PHP 48-8M-20RSB
50	127,32	125,95	131	1F	15	54	28,0	-	38	-	75,0	2,48	PHP 50-8M-20RSB
52	132,42	131,05	140	1F	15	54	28,0	-	38	-	80,0	2,52	PHP 52-8M-20RSB
56	142,60	141,23	151	2F	15	54	28,0	-	38	-	80,0	2,60	PHP 56-8M-20RSB
64	162,97	161,60	172	2F	15	54	28,0	-	38	-	80,0	2,90	PHP 64-8M-20RSB
72	183,35	181,97	192	2F	15	54	28,0	-	38	-	80,0	3,10	PHP 72-8M-20RSB
80	203,72	202,35	-	2	15	54	28,0	-	38	-	90,0	3,80	PHP 80-8M-20RSB
90	229,18	227,81	-	2	15	54	28,0	-	38	-	90,0	4,20	PHP 90-8M-20RSB
112	285,21	283,83	-	5	18	54	28,0	-	38	-	90,0	5,20	PHP 112-8M-20RSB
144	366,69	365,32	-	5	20	54	28,0	-	38	-	90,0	7,50	PHP 144-8M-20RSB
168	427,81	426,44	-	5	20	60	28,0	-	38	-	100,0	10,00	PHP 168-8M-20RSB
192	488,92	487,55	-	5	20	60	28,0	-	38	-	100,0	14,40	PHP 192-8M-20RSB



HiTD pulleys

Pilot bore (RSB)



8 mm Pitch

Type 1F

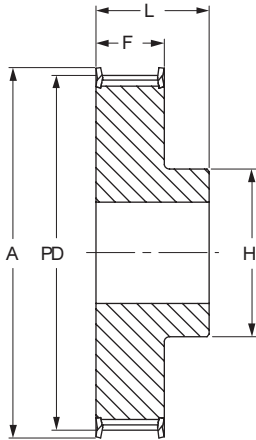

Type 2

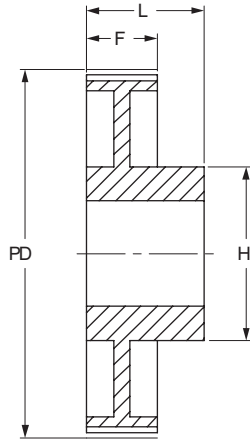

Type 2F

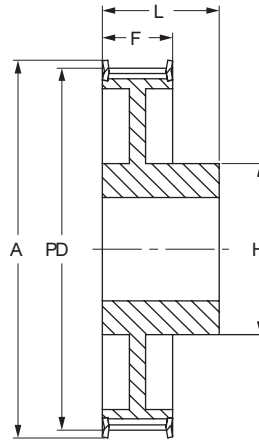

Type 5

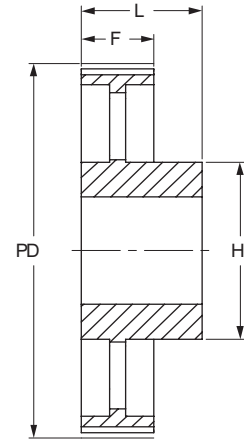

Belt Width 30 mm

No. Teeth	Diameter			Type	Bore		Dimensions					Weight	Designation
	P.D.	O.D.	A		Min	Max	F	K	L	M	H		
	mm	mm	mm		mm	mm	mm	mm	mm	mm	mm	mm	
20	50,93	49,56	60	1F	12	25	38	-	48	-	38	0,54	PHP 20-8M-30RSB
21	53,47	52,10	62	1F	12	27	38	-	48	-	40	0,62	PHP 21-8M-30RSB
22	56,02	54,65	65	1F	12	29	38	-	48	-	43	0,69	PHP 22-8M-30RSB
23	57,57	57,20	65	1F	12	30	38	-	48	-	45	0,77	PHP 23-8M-30RSB
24	61,12	59,75	70	1F	12	30	38	-	48	-	45	0,84	PHP 24-8M-30RSB
25	63,66	62,28	71	1F	12	31	38	-	48	-	50	0,92	PHP 25-8M-30RSB
26	66,21	64,84	75	1F	12	32	38	-	48	-	50	1,00	PHP 26-8M-30RSB
27	68,75	67,39	75	1F	12	33	38	-	48	-	50	1,06	PHP 27-8M-30RSB
28	71,30	70,08	80	1F	15	34	38	-	48	-	50	1,12	PHP 28-8M-30RSB
30	76,39	75,13	85	1F	15	36	38	-	48	-	55	1,32	PHP 30-8M-30RSB
31	78,94	77,65	87	1F	15	38	38	-	48	-	55	1,42	PHP 31-8M-30RSB
32	81,49	80,16	90	1F	15	40	38	-	48	-	60	1,53	PHP 32-8M-30RSB
33	84,03	82,68	90	1F	15	42	38	-	48	-	60	1,64	PHP 33-8M-30RSB
34	86,58	85,22	95	1F	15	44	38	-	48	-	70	1,80	PHP 34-8M-30RSB
35	89,13	87,76	95	1F	15	45	38	-	48	-	70	1,90	PHP 35-8M-30RSB
36	91,67	90,30	100	1F	15	46	38	-	48	-	70	1,99	PHP 36-8M-30RSB
38	96,77	95,39	105	1F	15	50	38	-	48	-	75	2,27	PHP 38-8M-30RSB
40	101,86	100,49	110	1F	15	50	38	-	48	-	75	2,40	PHP 40-8M-30RSB
42	106,95	105,58	111	1F	15	50	38	-	48	-	75	2,60	PHP 42-8M-30RSB
44	112,05	110,67	121	1F	15	50	38	-	48	-	75	2,80	PHP 44-8M-30RSB
45	114,59	113,22	121	1F	15	50	38	-	48	-	75	2,90	PHP 45-8M-30RSB
48	122,23	120,86	131	1F	15	50	38	-	48	-	75	3,20	PHP 48-8M-30RSB
50	127,32	125,95	131	1F	15	50	38	-	48	-	75	3,30	PHP 50-8M-30RSB
52	132,42	131,05	140	1F	15	60	38	-	48	-	90	3,40	PHP 52-8M-30RSB
56	142,60	141,23	151	2F	15	60	38	-	48	-	90	3,60	PHP 56-8M-30RSB
60	152,79	151,42	168	2F	15	60	38	-	48	-	90	3,95	PHP 60-8M-30RSB
64	162,97	161,60	172	2F	15	60	38	-	48	-	90	4,30	PHP 64-8M-30RSB
72	183,35	181,97	192	2F	15	63	38	-	48	-	95	4,80	PHP 72-8M-30RSB
80	203,72	202,35	-	2	15	60	38	-	48	-	100	5,10	PHP 80-8M-30RSB
90	229,18	227,81	-	2	15	60	38	-	48	-	100	5,70	PHP 90-8M-30RSB
112	285,21	283,83	-	5	18	60	38	-	48	-	100	6,80	PHP 112-8M-30RSB
144	366,69	365,32	-	5	20	60	38	-	48	-	100	9,30	PHP 144-8M-30RSB
168	427,81	426,44	-	5	20	60	38	-	48	-	100	11,40	PHP 168-8M-30RSB
192	488,92	487,55	-	5	20	60	38	-	48	-	100	16,00	PHP 192-8M-30RSB



HiTD pulleys

Pilot bore (RSB)

- ▶ Belts
- ▶ Chains
- ▶ Couplings
- ▶ Bushings and Hubs
- ▶ Sprockets
- ▶ Pulleys
- ▶ Smart tools

8 mm Pitch

Type 1F

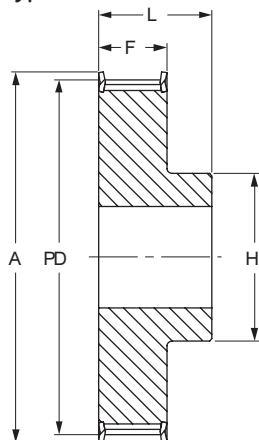

Type 3

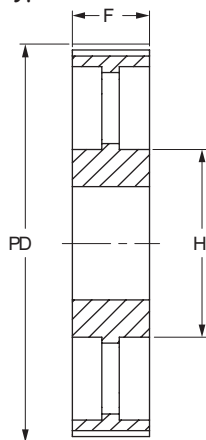

Type 7

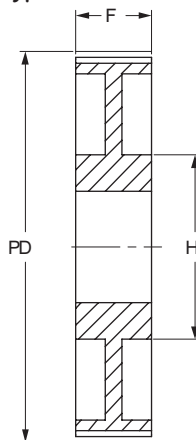

Type 7F

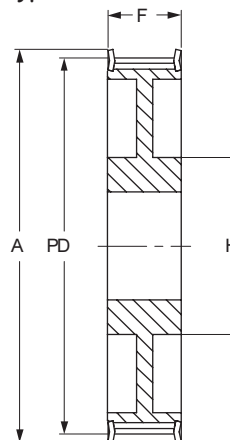

Belt Width 50 mm

No. Teeth	Diameter			Type	Bore		Dimensions					Weight kg	Designation
	P.D.	O.D.	A		Min	Max	F	K	L	M	H		
	mm	mm	mm		mm	mm	mm	mm	mm	mm	mm		
22	56,02	54,65	65	1F	12	29	60	-	70	-	43	1,00	PHP 22-8M-50RSB
23	58,57	57,20	65	1F	12	30	60	-	70	-	45	1,12	PHP 23-8M-50RSB
24	61,12	59,75	70	1F	12	30	60	-	70	-	45	1,23	PHP 24-8M-50RSB
25	63,66	62,28	70	1F	12	34	60	-	70	-	50	1,37	PHP 25-8M-50RSB
26	66,21	64,84	75	1F	12	34	60	-	70	-	50	1,50	PHP 26-8M-50RSB
27	68,75	67,39	75	1F	15	34	60	-	70	-	50	1,59	PHP 27-8M-50RSB
28	71,30	70,08	80	1F	15	34	60	-	70	-	50	1,67	PHP 28-8M-50RSB
30	76,39	75,13	85	1F	15	38	60	-	70	-	55	1,97	PHP 30-8M-50RSB
31	78,94	77,65	87	1F	15	38	60	-	70	-	55	2,12	PHP 31-8M-50RSB
32	81,49	80,16	90	1F	15	40	60	-	70	-	60	2,27	PHP 32-8M-50RSB
33	84,03	82,68	90	1F	15	42	60	-	70	-	60	2,42	PHP 33-8M-50RSB
34	86,58	85,22	95	1F	15	44	60	-	70	-	70	2,69	PHP 34-8M-50RSB
35	89,13	87,76	95	1F	15	45	60	-	70	-	70	2,83	PHP 35-8M-50RSB
36	91,67	90,30	100	1F	15	46	60	-	70	-	70	2,97	PHP 36-8M-50RSB
38	96,77	95,39	105	1F	15	50	60	-	70	-	75	3,23	PHP 38-8M-50RSB
40	101,86	100,49	110	1F	18	50	60	-	70	-	75	3,50	PHP 40-8M-50RSB
42	104,41	103,03	111	1F	18	50	60	-	70	-	75	3,70	PHP 42-8M-50RSB
44	112,05	110,67	121	1F	18	50	60	-	70	-	75	3,90	PHP 44-8M-50RSB
45	114,59	113,22	121	1F	18	50	60	-	70	-	75	4,00	PHP 45-8M-50RSB
48	122,23	120,86	131	1F	18	54	60	-	70	-	80	4,30	PHP 48-8M-50RSB
50	124,78	123,41	131	1F	18	54	60	-	70	-	80	4,48	PHP 50-8M-50RSB
52	127,32	125,95	140	1F	18	60	60	-	70	-	90	4,65	PHP 52-8M-50RSB
56	142,60	141,23	151	7F	18	60	60	-	60	-	90	5,00	PHP 56-8M-50RSB
60	152,79	151,42	158	7F	18	60	60	-	60	-	90	5,30	PHP 60-8M-50RSB
64	162,97	161,60	171	7F	18	60	60	-	60	-	100	5,60	PHP 64-8M-50RSB
72	183,35	181,97	192	7F	18	63	60	-	60	-	100	6,80	PHP 72-8M-50RSB
80	203,72	202,35	-	7	18	60	60	-	60	-	110	6,90	PHP 80-8M-50RSB
90	229,18	227,81	-	7	18	60	60	-	60	-	110	8,60	PHP 90-8M-50RSB
112	285,21	283,83	-	3	20	60	60	-	60	-	110	9,60	PHP 112-8M-50RSB
144	366,69	365,32	-	3	20	60	60	-	60	-	110	13,80	PHP 144-8M-50RSB
168	427,81	426,44	-	3	20	60	60	-	60	-	120	16,00	PHP 168-8M-50RSB
192	488,92	487,55	-	3	20	60	60	-	60	-	130	22,40	PHP 192-8M-50RSB



HiTD pulleys

Pilot bore (RSB)



8 mm Pitch

Type 1F

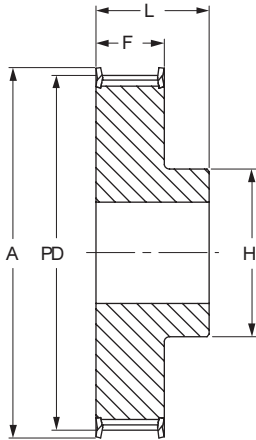

Type 3

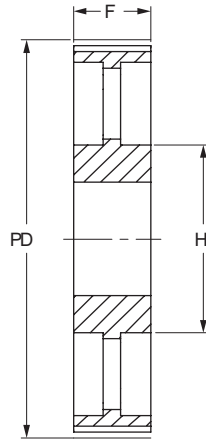

Type 7F

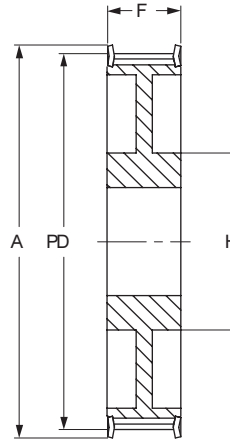

Belt Width 85 mm

No. Teeth	Diameter			Type	Bore		Dimensions					Weight	Designation
	P.D.	O.D.	A		Min	Max	F	K	L	M	H		
	mm	mm	mm		mm	mm	mm	mm	mm	mm	mm	kg	
22	56,02	54,65	65	1F	12	29	95	-	105	-	43	1,55	PHP 22-8M-85RSB
23	58,57	57,20	65	1F	12	30	95	-	105	-	45	1,73	PHP 23-8M-85RSB
24	61,12	59,75	70	1F	12	30	95	-	105	-	45	1,90	PHP 24-8M-85RSB
25	63,66	62,28	70	1F	12	34	95	-	105	-	50	2,08	PHP 25-8M-85RSB
26	66,21	64,84	75	1F	12	34	95	-	105	-	50	2,25	PHP 26-8M-85RSB
27	68,75	67,39	75	1F	12	34	95	-	105	-	50	2,40	PHP 27-8M-85RSB
28	71,30	70,08	80	1F	15	34	95	-	105	-	50	2,55	PHP 28-8M-85RSB
30	76,39	75,13	85	1F	15	35	95	-	105	-	55	3,00	PHP 30-8M-85RSB
31	78,94	77,65	87	1F	15	38	95	-	105	-	55	3,23	PHP 31-8M-85RSB
32	81,49	80,16	90	1F	15	42	95	-	105	-	60	3,57	PHP 32-8M-85RSB
33	84,03	82,68	90	1F	15	44	95	-	105	-	60	3,75	PHP 33-8M-85RSB
34	86,58	85,22	95	1F	15	44	95	-	105	-	70	4,00	PHP 34-8M-85RSB
35	89,13	87,76	95	1F	15	44	95	-	105	-	70	4,25	PHP 35-8M-85RSB
36	91,67	90,30	100	1F	15	44	95	-	105	-	70	4,50	PHP 36-8M-85RSB
38	96,77	95,39	106	1F	15	50	95	-	105	-	75	4,90	PHP 38-8M-85RSB
40	101,86	100,49	110	1F	18	50	95	-	105	-	75	5,20	PHP 40-8M-85RSB
42	106,95	105,58	110	1F	18	50	95	-	105	-	75	6,08	PHP 42-8M-85RSB
44	112,05	110,67	121	1F	18	50	95	-	105	-	75	6,60	PHP 44-8M-85RSB
45	114,59	113,22	121	1F	18	50	95	-	105	-	75	6,85	PHP 45-8M-85RSB
48	122,23	120,86	131	1F	18	54	95	-	105	-	80	7,60	PHP 48-8M-85RSB
50	127,32	125,95	131	1F	20	54	95	-	105	-	80	8,15	PHP 50-8M-85RSB
52	132,42	131,05	140	1F	20	54	95	-	105	-	80	8,70	PHP 52-8M-85RSB
56	142,60	141,23	151	1F	20	54	95	-	105	-	80	9,80	PHP 56-8M-85RSB
60	152,79	151,42	158	7F	20	66	95	-	95	-	100	10,10	PHP 60-8M-85RSB
64	162,97	161,60	171	7F	20	66	95	-	95	-	100	10,40	PHP 64-8M-85RSB
72	183,35	181,97	192	7F	20	66	95	-	95	-	110	11,40	PHP 72-8M-85RSB
80	203,72	202,35	-	3	20	66	95	-	95	-	110	11,10	PHP 80-8M-85RSB
90	229,18	227,81	-	3	20	66	95	-	95	-	110	13,20	PHP 90-8M-85RSB
112	285,21	283,83	-	3	24	66	95	-	95	-	110	16,30	PHP 112-8M-85RSB
144	366,69	365,32	-	3	24	72	95	-	95	-	120	21,50	PHP 144-8M-85RSB
168	427,81	426,44	-	3	24	72	95	-	95	-	120	26,10	PHP 168-8M-85RSB
192	488,92	487,55	-	3	24	78	95	-	95	-	130	30,60	PHP 192-8M-85RSB



HiTD pulleys

Pilot bore (RSB)

- ▶ Belts
- ▶ Chains
- ▶ Couplings
- ▶ Bushings and Hubs
- ▶ Sprockets
- ▶ Pulleys
- ▶ Smart tools

14 mm Pitch

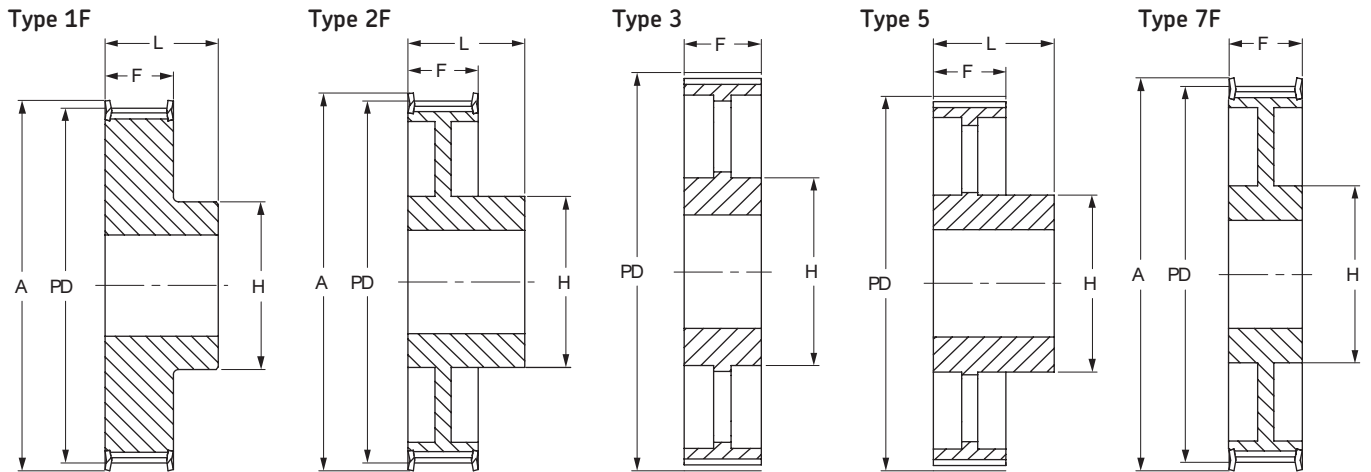

Belt Width 40 mm

No. Teeth	Diameter			Type	Bore		Dimensions					Weight kg	Designation
	P.D.	O.D.	A		Min	Max	F	K	L	M	H		
	mm	mm	mm		mm	mm	mm	mm	mm	mm	mm		
28	124,78	122,12	127	1F	24	67	54	-	69	-	100	4,73	PHP 28-14M-40RSB
29	129,23	126,57	138	1F	24	67	54	-	69	-	100	5,09	PHP 29-14M-40RSB
30	133,69	130,99	138	1F	24	67	54	-	69	-	100	5,45	PHP 30-14M-40RSB
32	142,60	139,88	154	1F	24	67	54	-	69	-	100	6,17	PHP 32-14M-40RSB
34	151,52	148,79	160	1F	24	67	54	-	69	-	100	6,88	PHP 34-14M-40RSB
36	160,43	157,68	168	1F	24	67	54	-	69	-	100	7,60	PHP 36-14M-40RSB
38	169,34	166,60	183	1F	24	80	54	-	69	-	120	8,28	PHP 38-14M-40RSB
40	178,25	175,49	188	1F	24	80	54	-	69	-	120	9,26	PHP 40-14M-40RSB
44	196,08	193,28	211	1F	24	80	54	-	69	-	120	10,32	PHP 44-14M-40RSB
48	213,90	211,11	226	2F	24	82	54	-	69	-	135	11,50	PHP 48-14M-40RSB
56	249,55	246,76	256	2F	28	82	54	-	69	-	135	13,05	PHP 56-14M-40RSB
64	285,21	282,41	296	2F	28	82	54	-	69	-	135	14,40	PHP 64-14M-40RSB
72	320,86	318,06	-	5	28	82	54	-	69	-	135	16,90	PHP 72-14M-40RSB
80	356,51	353,71	-	5	28	82	54	-	69	-	135	18,50	PHP 80-14M-40RSB
90	401,07	398,28	-	5	28	82	54	-	69	-	135	20,00	PHP 90-14M-40RSB
112	499,11	496,32	-	5	28	82	54	-	69	-	135	26,70	PHP 112-14M-40RSB
144	641,71	638,92	-	5	28	82	54	-	69	-	135	35,00	PHP 144-14M-40RSB
168	748,66	745,87	-	5	28	82	54	-	69	-	135	44,20	PHP 168-14M-40RSB
192	855,92	852,82	-	5	28	82	54	-	69	-	135	52,20	PHP 192-14M-40RSB
216	962,57	959,76	-	5	28	90	54	-	69	-	150	60,00	PHP 216-14M-40RSB

Belt Width 55 mm

No. Teeth	Diameter			Type	Bore		Dimensions					Weight kg	Designation
	P.D.	O.D.	A		Min	Max	F	K	L	M	H		
	mm	mm	mm		mm	mm	mm	mm	mm	mm	mm		
28	124,78	122,12	127	1F	24	67	70	-	85	-	100	5,60	PHP 28-14M-55RSB
29	129,23	126,57	138	1F	24	67	70	-	85	-	100	6,10	PHP 29-14M-55RSB
30	133,69	130,99	138	1F	24	67	70	-	85	-	100	6,60	PHP 30-14M-55RSB
32	142,60	139,88	154	1F	24	67	70	-	85	-	100	7,60	PHP 32-14M-55RSB
34	151,52	148,79	160	1F	24	67	70	-	85	-	100	8,60	PHP 34-14M-55RSB
36	160,43	157,68	168	1F	24	67	70	-	85	-	100	9,60	PHP 36-14M-55RSB
38	169,34	166,60	183	1F	24	80	70	-	85	-	120	10,80	PHP 38-14M-55RSB
40	178,25	175,49	188	1F	24	80	70	-	85	-	120	11,20	PHP 40-14M-55RSB
44	196,08	193,28	211	1F	24	80	70	-	85	-	120	12,50	PHP 44-14M-55RSB
48	213,90	211,11	226	7F	24	82	70	-	70	-	135	13,70	PHP 48-14M-55RSB
56	249,55	246,76	256	7F	28	82	70	-	70	-	135	14,50	PHP 56-14M-55RSB
64	285,21	282,41	296	7F	28	82	70	-	70	-	135	15,60	PHP 64-14M-55RSB
72	320,86	318,06	-	3	28	82	70	-	70	-	135	18,50	PHP 72-14M-55RSB
80	356,51	353,71	-	3	28	82	70	-	70	-	135	20,00	PHP 80-14M-55RSB
90	401,07	398,28	-	3	28	82	70	-	70	-	135	22,60	PHP 90-14M-55RSB
112	499,11	496,32	-	3	28	82	70	-	70	-	135	29,50	PHP 112-14M-55RSB
144	641,71	638,92	-	3	28	82	70	-	70	-	135	39,00	PHP 144-14M-55RSB
168	748,66	745,87	-	3	28	82	70	-	70	-	135	48,50	PHP 168-14M-55RSB
192	855,92	852,82	-	3	28	82	70	-	70	-	135	57,80	PHP 192-14M-55RSB
216	962,57	959,76	-	3	28	82	70	-	70	-	150	67,00	PHP 216-14M-55RSB



HiTD pulleys

Pilot bore (RSB)



14 mm Pitch

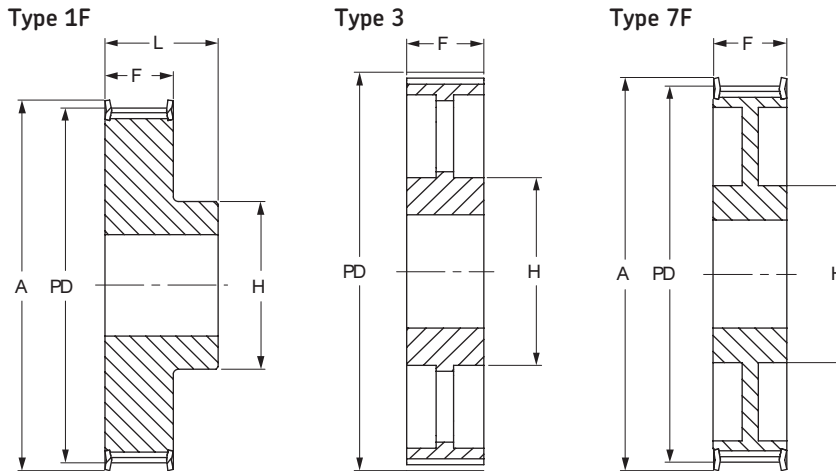

Belt Width 85 mm

No. Teeth	Diameter			Type	Bore		Dimensions					Weight kg	Designation
	P.D.	O.D.	A		Min	Max	F	K	L	M	H		
	mm	mm	mm		mm	mm	mm	mm	mm	mm	mm		
28	124,78	122,12	127	1F	24	67	102	-	117	-	100	7,70	PHP 28-14M-85RSB
29	129,23	126,57	138	1F	24	67	102	-	117	-	100	8,40	PHP 29-14M-85RSB
30	133,69	130,99	138	1F	24	67	102	-	117	-	100	9,10	PHP 30-14M-85RSB
32	142,60	139,88	154	1F	24	67	102	-	117	-	100	10,50	PHP 32-14M-85RSB
34	151,52	148,79	160	1F	24	67	102	-	117	-	100	11,90	PHP 34-14M-85RSB
36	160,43	157,68	168	1F	32	67	102	-	117	-	100	13,20	PHP 36-14M-85RSB
38	169,34	166,60	183	1F	32	80	102	-	117	-	120	15,15	PHP 38-14M-85RSB
40	178,25	175,49	188	1F	32	90	102	-	117	-	135	17,10	PHP 40-14M-85RSB
44	196,08	193,28	211	1F	32	90	102	-	117	-	135	23,30	PHP 44-14M-85RSB
48	213,90	211,11	226	1F	32	100	102	-	117	-	150	25,00	PHP 48-14M-85RSB
56	249,55	246,76	256	7F	32	90	102	-	102	-	150	25,00	PHP 56-14M-85RSB
64	285,21	282,41	296	7F	32	90	102	-	102	-	150	28,20	PHP 64-14M-85RSB
72	320,86	318,06	-	3	32	90	102	-	102	-	150	28,80	PHP 72-14M-85RSB
80	356,51	353,71	-	3	32	90	102	-	102	-	150	30,10	PHP 80-14M-85RSB
90	401,07	398,28	-	3	32	90	102	-	102	-	150	33,00	PHP 90-14M-85RSB
112	499,11	496,32	-	3	32	90	102	-	102	-	150	41,80	PHP 112-14M-85RSB
144	641,71	638,92	-	3	32	90	102	-	102	-	150	52,40	PHP 144-14M-85RSB
168	748,66	745,87	-	3	32	90	102	-	102	-	150	60,30	PHP 168-14M-85RSB
192	855,62	852,82	-	3	32	100	102	-	102	-	165	70,20	PHP 192-14M-85RSB
216	962,57	959,76	-	3	32	100	102	-	102	-	165	81,00	PHP 216-14M-85RSB

Belt Width 115 mm

No. Teeth	Diameter			Type	Bore		Dimensions					Weight kg	Designation
	P.D.	O.D.	A		Min	Max	F	K	L	M	H		
	mm	mm	mm		mm	mm	mm	mm	mm	mm	mm		
28	124,78	122,12	127	1F	32	67	133	-	148	-	100	9,20	PHP 28-14M-115RSB
29	129,23	126,57	138	1F	32	67	133	-	148	-	100	10,20	PHP 29-14M-115RSB
30	133,69	130,99	138	1F	32	67	133	-	148	-	100	11,20	PHP 30-14M-115RSB
32	142,60	139,88	154	1F	32	67	133	-	148	-	100	13,20	PHP 32-14M-115RSB
34	151,52	148,79	160	1F	32	67	133	-	148	-	100	14,80	PHP 34-14M-115RSB
36	160,43	157,68	168	1F	32	80	133	-	148	-	120	16,60	PHP 36-14M-115RSB
38	169,34	166,60	183	1F	32	80	133	-	148	-	120	19,20	PHP 38-14M-115RSB
40	178,25	175,49	188	1F	32	90	133	-	148	-	135	20,56	PHP 40-14M-115RSB
44	196,08	193,28	211	1F	32	94	133	-	148	-	140	26,00	PHP 44-14M-115RSB
48	213,90	211,11	226	1F	32	100	133	-	148	-	150	30,00	PHP 48-14M-115RSB
56	249,55	246,76	256	1F	32	100	133	-	148	-	150	36,00	PHP 56-14M-115RSB
64	285,21	282,41	296	7F	32	90	133	-	133	-	150	39,00	PHP 64-14M-115RSB
72	320,86	318,06	-	3	32	90	133	-	133	-	150	32,83	PHP 72-14M-115RSB
80	356,51	353,71	-	3	32	90	133	-	133	-	150	35,55	PHP 80-14M-115RSB
90	401,07	398,28	-	3	32	90	133	-	133	-	150	41,00	PHP 90-14M-115RSB
112	499,11	496,32	-	3	32	90	133	-	133	-	150	54,40	PHP 112-14M-115RSB
144	641,71	638,92	-	3	32	100	133	-	133	-	165	67,80	PHP 144-14M-115RSB
168	748,66	745,87	-	3	32	100	133	-	133	-	165	75,80	PHP 168-14M-115RSB
192	855,62	852,82	-	3	32	100	133	-	133	-	165	90,30	PHP 192-14M-115RSB
216	962,57	959,76	-	3	32	100	133	-	133	-	165	105,00	PHP 216-14M-115RSB



HiTD pulleys

Pilot bore (RSB)

- ▶ Belts
- ▶ Chains
- ▶ Couplings
- ▶ Bushings and Hubs
- ▶ Sprockets
- ▶ Pulleys
- ▶ Smart tools

14 mm Pitch

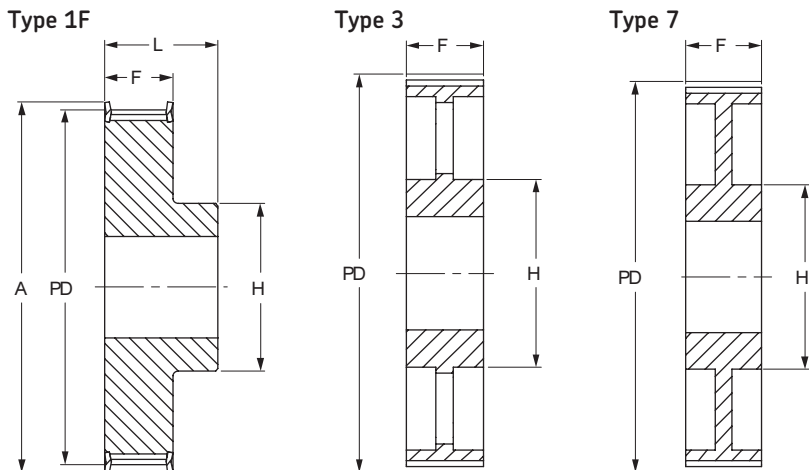

Belt Width 170 mm

No. Teeth	Diameter			Type	Bore		Dimensions					Weight kg	Designation
	P.D.	O.D.	A		Min	Max	F	K	L	M	H		
	mm	mm	mm		mm	mm	mm	mm	mm	mm	mm		
28	124,78	122,12	127	1F	32	67	187	-	202	-	100	13,80	PHP 28-14M-170RSB
29	129,23	126,57	138	1F	32	67	187	-	202	-	100	14,20	PHP 29-14M-170RSB
30	133,69	130,99	138	1F	32	67	187	-	202	-	100	15,60	PHP 30-14M-170RSB
32	142,60	139,88	154	1F	32	67	187	-	202	-	100	18,10	PHP 32-14M-170RSB
34	151,52	148,79	160	1F	32	67	187	-	202	-	100	20,40	PHP 34-14M-170RSB
36	160,43	157,68	168	1F	32	80	187	-	202	-	120	23,50	PHP 36-14M-170RSB
38	169,34	166,60	183	1F	32	90	187	-	202	-	135	26,50	PHP 38-14M-170RSB
40	178,25	175,49	188	1F	32	94	187	-	202	-	140	30,10	PHP 40-14M-170RSB
44	196,08	193,28	211	1F	32	100	187	-	202	-	160	37,80	PHP 44-14M-170RSB
48	213,90	211,11	226	1F	32	107	187	-	202	-	160	44,50	PHP 48-14M-170RSB
56	249,55	246,76	256	1F	32	110	187	-	202	-	160	61,00	PHP 56-14M-170RSB
64	285,21	282,41	296	1F	32	120	187	-	202	-	180	81,00	PHP 64-14M-170RSB
72	320,86	318,06	-	7	32	120	187	-	187	-	180	61,40	PHP 72-14M-170RSB
80	356,51	353,71	-	7	32	108	187	-	187	-	180	65,00	PHP 80-14M-170RSB
90	401,07	398,28	-	3	38	108	187	-	187	-	180	68,00	PHP 90-14M-170RSB
112	499,11	496,32	-	3	38	108	187	-	187	-	200	87,50	PHP 112-14M-170RSB
144	641,71	638,92	-	3	38	108	187	-	187	-	220	114,80	PHP 144-14M-170RSB
168	748,66	745,87	-	3	38	108	187	-	187	-	220	125,00	PHP 168-14M-170RSB
192	855,62	852,82	-	3	38	108	187	-	187	-	220	136,40	PHP 192-14M-170RSB
216	962,57	959,76	-	3	38	108	187	-	187	-	220	147,00	PHP 216-14M-170RSB



HiTD pulleys

Taper bushed



5 mm Pitch

Type 3F

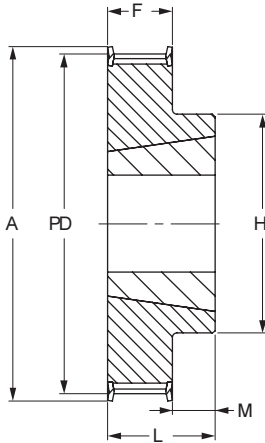

Type 10

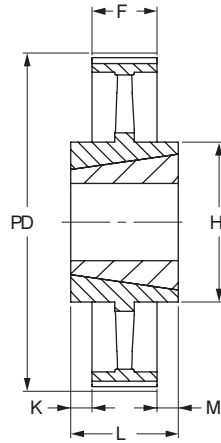

Belt Width 15 mm

No. Teeth	Diameter			Type	Bush No.	Bore		Dimensions					Weight	Designation
	P.D.	O.D.	A			Min	Max	F	K	L	M	H		
	mm	mm	mm			mm	mm	mm	mm	mm	mm	mm	mm	
34	54,11	52,97	58	3F	1008	9	25	20,5	-	22	1,5	43	0,19	PHP 34-5M-15TB
36	57,30	56,16	61	3F	1108	9	28	20,5	-	22	1,5	45	0,20	PHP 36-5M-15TB
38	60,48	59,34	65	3F	1108	9	28	20,5	-	22	1,5	48	0,25	PHP 38-5M-15TB
40	63,66	62,52	68	3F	1108	9	28	20,5	-	22	1,5	52	0,31	PHP 40-5M-15TB
44	70,03	68,89	74	3F	1108	9	28	20,5	-	22	1,5	54	0,40	PHP 44-5M-15TB
48	76,39	75,25	80	3F	1210	11	32	20,5	-	25	4,5	64	0,45	PHP 48-5M-15TB
56	89,13	87,99	93	3F	1210	11	32	20,5	-	25	4,5	70	0,67	PHP 56-5M-15TB
64	101,86	100,72	106	3F	1210	11	32	20,5	-	25	4,5	78	0,96	PHP 64-5M-15TB
72	114,59	113,45	118	3F	1610	14	42	20,5	-	25	4,5	90	1,19	PHP 72-5M-15TB
80	127,32	126,18	135	3F	1610	14	42	20,5	-	25	4,5	92	1,57	PHP 80-5M-15TB
90	143,24	142,10	-	10	1610	14	42	20,5	2,3	25	2,3	92	1,47	PHP 90-5M-15TB
112	178,25	177,11	-	10	1610	14	42	20,5	2,3	25	2,3	92	1,94	PHP 112-5M-15TB
136	216,45	215,31	-	10	2012	14	50	20,5	5,8	32	5,8	106	3,06	PHP 136-5M-15TB
150	238,73	237,51	-	10	2012	14	50	20,5	5,8	32	5,8	106	4,50	PHP 150-5M-15TB



HiTD pulleys

Taper bushed

- ▶ Belts
- ▶ Chains
- ▶ Couplings
- ▶ Bushings and Hubs
- ▶ Sprockets
- ▶ Pulleys
- ▶ Smart tools

8 mm Pitch

Type 3F

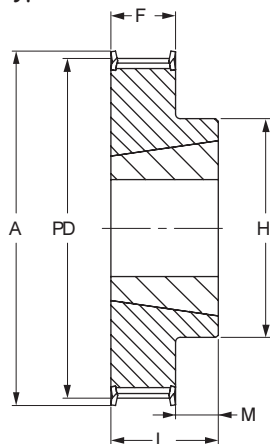

Type 4F

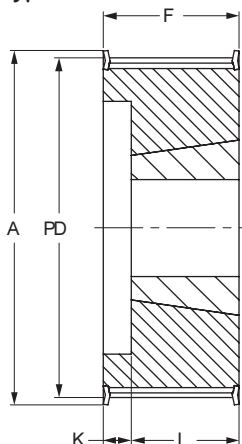

Type 12

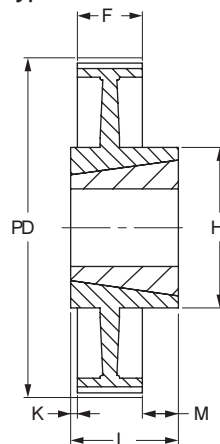

Type 12F

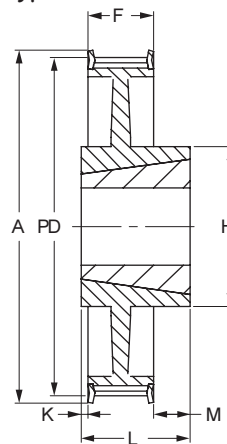

Belt Width 20 mm

No. Teeth	Diameter			Type	Bush No.	Bore		Dimensions					Weight kg	Designation
	P.D.	O.D.	A			Min	Max	F	K	L	M	H		
	mm	mm	mm			mm	mm	mm	mm	mm	mm	mm		
22	56.02	54.65	65	4F	1008	9	25	28	6	22	-	-	0.24	PHP 22-8M-20TB
24	61.12	59.75	70	4F	1108	9	28	28	6	22	-	-	0.30	PHP 24-8M-20TB
26	66.21	64.84	75	4F	1108	9	28	28	6	22	-	-	0.36	PHP 26-8M-20TB
28	71.30	70.08	80	4F	1108	9	28	28	6	22	-	-	0.44	PHP 28-8M-20TB
30	76.39	75.13	85	4F	1108	11	28	28	6	22	-	-	0.45	PHP 30-8M-20TB
32	81.49	80.16	90	4F	1610	11	42	28	3	25	-	-	0.50	PHP 32-8M-20TB
34	86.58	85.22	95	4F	1610	14	42	28	3	25	-	-	0.55	PHP 34-8M-20TB
36	91.67	90.30	100	4F	1610	14	42	28	3	25	-	-	0.68	PHP 36-8M-20TB
38	96.77	95.39	106	4F	1610	14	42	28	3	25	-	-	0.80	PHP 38-8M-20TB
40	101.86	100.49	110	4F	1610	14	42	28	3	25	-	-	1.00	PHP 40-8M-20TB
42	106.95	105.58	110	4F	1610	14	42	28	3	25	-	-	1.11	PHP 42-8M-20TB
44	112.05	110.67	121	3F	2012	14	50	28	-	32	4	92	1.20	PHP 44-8M-20TB
48	122.23	120.86	131	3F	2012	14	50	28	-	32	4	96	1.60	PHP 48-8M-20TB
56	142.60	141.23	151	3F	2012	14	50	28	-	32	4	110	2.40	PHP 56-8M-20TB
60	152.79	151.42	162	3F	2012	14	50	28	-	32	4	110	2.55	PHP 60-8M-20TB
64	162.97	161.60	171	12F	2012	14	50	28	-	32	4	110	2.70	PHP 64-8M-20TB
72	183.35	181.97	192	12F	2012	14	50	28	-	32	4	110	3.30	PHP 72-8M-20TB
80	203.72	202.35	-	12	2012	16	50	28	-	32	4	110	3.50	PHP 80-8M-20TB
90	229.18	227.81	-	12	2012	16	50	28	-	32	4	110	3.65	PHP 90-8M-20TB



HiTD pulleys

Taper bushed



8 mm Pitch

Type 2F

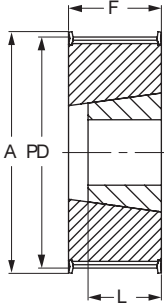

Type 3F

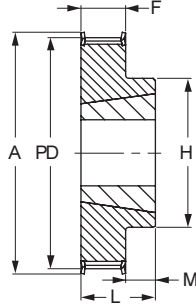

Type 6F

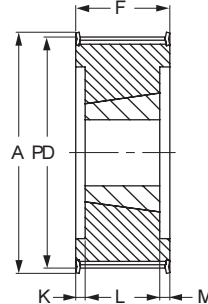

Type 12

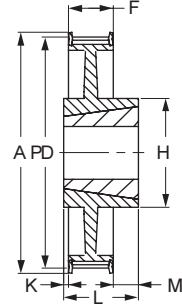

Type 4F

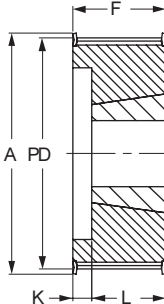

Type 10

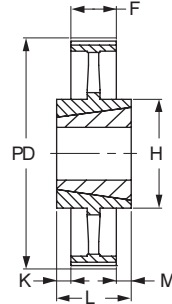

Type 12F

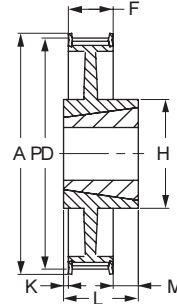

Belt Width 30 mm

No. Teeth	Diameter			Type	Bush No.	Bore		Dimensions					Weight kg	Designation
	P.D.	O.D.	A			Min	Max	F	K	L	M	H		
	mm	mm	mm			mm	mm	mm	mm	mm	mm	mm		
20	50,93	49,56	60	4F	1008	9	25	38	16	22	-	-	0,23	PHP 20-8M-30TB
21	53,47	52,10	65	4F	1008	9	25	38	16	22	-	-	0,26	PHP 21-8M-30TB
22	56,02	54,65	65	4F	1008	9	25	38	16	22	-	-	0,29	PHP 22-8M-30TB
23	58,57	57,20	70	4F	1108	9	28	38	16	22	-	-	0,32	PHP 23-8M-30TB
24	61,12	59,75	70	4F	1108	9	28	38	16	22	-	-	0,38	PHP 24-8M-30TB
25	63,66	62,29	75	4F	1108	9	28	38	16	22	-	-	0,41	PHP 25-8M-30TB
26	66,21	64,84	75	4F	1108	9	28	38	16	22	-	-	0,45	PHP 26-8M-30TB
27	68,75	67,38	80	4F	1108	9	28	38	16	22	-	-	0,49	PHP 27-8M-30TB
28	71,30	70,08	80	4F	1210	11	32	38	16	25	-	-	0,50	PHP 28-8M-30TB
30	76,39	75,13	85	2F	1615	11	42	38	-	38	-	-	0,55	PHP 30-8M-30TB
31	78,94	77,57	90	2F	1615	14	42	38	-	38	-	-	0,57	PHP 31-8M-30TB
32	81,49	80,16	90	2F	1615	14	42	38	-	38	-	-	0,59	PHP 32-8M-30TB
33	84,03	82,66	95	2F	1615	14	42	38	-	38	-	-	0,73	PHP 33-8M-30TB
34	86,58	85,22	95	2F	1615	14	42	38	-	38	-	-	0,77	PHP 34-8M-30TB
35	89,13	87,75	100	2F	1615	14	42	38	-	38	-	-	0,82	PHP 35-8M-30TB
36	91,67	90,30	100	2F	1615	14	42	38	-	38	-	-	0,96	PHP 36-8M-30TB
38	96,77	95,39	106	2F	1615	14	42	38	-	38	-	-	1,15	PHP 38-8M-30TB
40	101,86	100,49	110	2F	1615	14	42	38	-	38	-	-	1,34	PHP 40-8M-30TB
42	106,95	105,58	110	2F	1615	14	42	38	-	38	-	-	1,36	PHP 42-8M-30TB
44	112,05	110,67	121	6F	2012	14	50	38	6	32	-	-	1,33	PHP 44-8M-30TB
45	114,59	113,22	121	6F	2012	14	50	38	6	32	-	-	1,62	PHP 45-8M-30TB
48	122,23	120,86	131	6F	2012	14	50	38	6	32	-	-	1,78	PHP 48-8M-30TB
50	127,32	125,95	136	6F	2012	14	50	38	3	32	3	-	2,08	PHP 50-8M-30TB
52	132,42	131,04	141	6F	2012	14	50	38	3	32	3	-	2,39	PHP 52-8M-30TB
56	142,60	141,23	151	6F	2012	14	50	38	6	32	-	-	3,76	PHP 56-8M-30TB
58	147,70	146,32	156	6F	2012	14	50	38	3	32	3	-	3,87	PHP 58-8M-30TB
60	152,79	151,42	162	6F	2517	16	60	38	3	45	3	-	3,98	PHP 60-8M-30TB
64	162,97	161,60	171	3F	2517	16	60	38	-	45	7	125	4,20	PHP 64-8M-30TB
72	183,35	181,97	192	12F	2517	16	60	38	-	45	7	125	4,30	PHP 72-8M-30TB
80	203,72	202,35	-	12	2517	16	60	38	-	45	7	125	4,60	PHP 80-8M-30TB
90	229,18	227,81	-	12	2517	16	60	38	-	45	7	125	5,00	PHP 90-8M-30TB
112	285,21	283,83	-	12	2517	16	60	38	-	45	7	125	6,20	PHP 112-8M-30TB
144	366,69	365,32	-	12	2517	16	60	38	-	45	7	125	9,00	PHP 144-8M-30TB
168	427,81	426,44	-	10	3020	25	75	38	7	51	7	170	15,00	PHP 168-8M-30TB
192	488,92	487,55	-	10	3525	35	100	38	14	65	7	198	18,50	PHP 192-8M-30TB



HiTD pulleys

Taper bush

- ▶ Belts
- ▶ Chains
- ▶ Couplings
- ▶ Bushings and Hubs
- ▶ Sprockets
- ▶ Pulleys
- ▶ Smart tools

8 mm Pitch

Type 4F

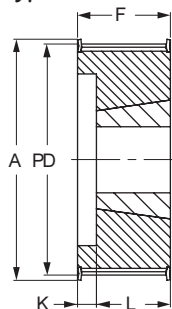

Type 6

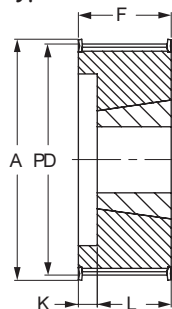

Type 6F

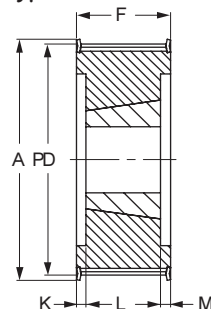

Type 7

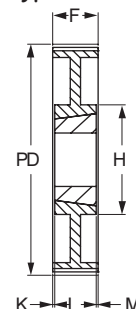

Type 7F

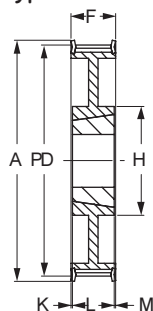

Type 8

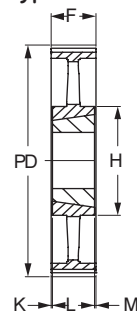

Type 10

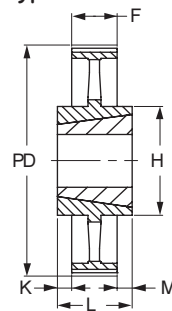

Belt Width 50 mm

No. Teeth	Diameter			Type	Bush No.	Bore		Dimensions					Weight	Designation
	P.D.	O.D.	A			Min	Max	F	K	L	M	H		
	mm	mm	mm			mm	mm	mm	mm	mm	mm	mm		
24	61,12	59,75	70	6F	1108	9	32	60	19,0	22	19,0	-	0,35	PHP 24-8M-50TB
26	66,21	64,84	75	6F	1108	9	32	60	19,0	22	19,0	-	0,48	PHP 26-8M-50TB
27	68,75	67,38	75	6F	1108	9	32	60	19,0	22	19,0	-	0,55	PHP 27-8M-50TB
28	71,30	70,08	80	4F	1210	11	32	60	35,0	22	35,0	-	0,60	PHP 28-8M-50TB
30	76,39	75,13	85	4F	1615	14	42	60	23,0	25	-	-	0,65	PHP 30-8M-50TB
31	78,94	77,57	87	4F	1615	14	42	60	23,0	25	-	-	0,77	PHP 31-8M-50TB
32	81,49	80,16	90	4F	1615	14	42	60	23,0	25	-	-	0,82	PHP 32-8M-50TB
33	84,03	82,66	90	4F	1615	14	42	60	23,0	25	-	-	0,98	PHP 33-8M-50TB
34	86,58	85,22	95	4F	1615	14	42	60	23,0	25	-	-	1,06	PHP 34-8M-50TB
35	89,13	87,75	95	4F	1615	14	42	60	23,0	25	-	-	1,18	PHP 35-8M-50TB
36	91,67	90,30	100	4F	1615	14	42	60	23,0	25	-	-	1,30	PHP 36-8M-50TB
38	96,77	95,39	105	4F	1615	14	42	60	23,0	25	-	-	1,60	PHP 38-8M-50TB
40	101,86	100,49	110	4F	2012	14	50	60	29,0	32	-	-	1,71	PHP 40-8M-50TB
42	106,95	105,58	111	4F	2012	14	50	60	29,0	32	28,0	-	1,75	PHP 42-8M-50TB
44	112,05	110,67	121	6F	2012	14	50	60	-	32	28,0	-	1,78	PHP 44-8M-50TB
45	114,59	113,22	121	6F	2012	14	50	60	-	32	28,0	-	1,91	PHP 45-8M-50TB
48	122,23	120,86	131	6F	2012	14	50	60	-	32	28,0	-	2,30	PHP 48-8M-50TB
50	127,32	125,95	131	6F	2012	14	50	60	-	32	28,0	-	2,58	PHP 50-8M-50TB
52	132,42	131,04	140	6F	2012	14	50	60	-	32	28,0	-	2,85	PHP 52-8M-50TB
56	142,60	141,23	151	6F	2517	16	60	60	-	45	15,0	-	3,40	PHP 56-8M-50TB
58	147,70	146,32	156	6F	2517	16	60	60	-	45	15,0	-	3,80	PHP 58-8M-50TB
60	152,79	151,42	158	6F	2517	16	60	60	-	45	15,0	-	4,20	PHP 60-8M-50TB
64	162,97	161,60	171	6F	2517	16	60	60	-	45	15,0	-	5,00	PHP 64-8M-50TB
72	183,35	181,97	192	7F	2517	16	60	60	7,5	45	7,5	125	6,70	PHP 72-8M-50TB
80	203,72	202,35	-	6	3020	25	75	60	4,5	45	4,5	-	8,80	PHP 80-8M-50TB
90	229,18	227,81	-	7	3020	25	75	60	4,5	51	4,5	160	10,00	PHP 90-8M-50TB
112	285,21	283,83	-	7	3020	25	75	60	4,5	51	4,5	170	12,00	PHP 112-8M-50TB
168	427,81	426,44	-	10	3525	25	100	60	4,5	51	4,5	170	16,40	PHP 168-8M-50TB
192	488,92	487,55	-	10	3525	25	100	60	4,5	51	4,5	170	21,80	PHP 192-8M-50TB
144	366,69	365,32	-	8	3020	25	75	60	4,5	51	4,5	170	15,20	PHP 144-8M-50TB



HiTD pulleys

Taper bushed



8 mm Pitch

Type 6F

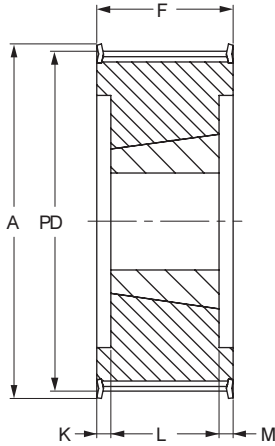

Type 7

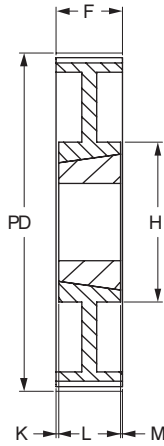

Type 7F

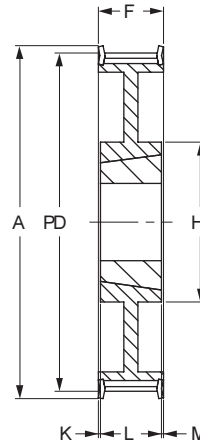

Type 8

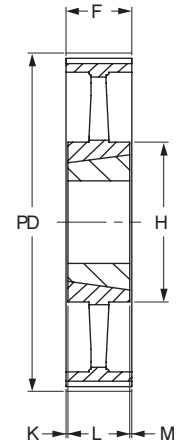

Belt Width 85 mm

No. Teeth	Diameter			Type	Bush No.	Bore		Dimensions					Weight kg	Designation
	P.D.	O.D.	A			Min	Max	F	K	L	M	H		
24	61,12	59,75	70	6F	1108	9	28	95	36,5	22	36,5	-	0,46	PHP 24-8M-85TB
26	66,21	64,84	75	6F	1108	9	28	95	36,5	22	36,5	-	0,64	PHP 26-8M-85TB
28	71,30	70,08	80	6F	1108	9	28	95	36,5	22	36,5	-	0,82	PHP 28-8M-85TB
30	76,39	75,13	85	6F	1615	14	42	95	36,5	22	36,5	-	1,17	PHP 30-8M-85TB
33	84,03	82,66	90	6F	1615	14	42	95	36,5	22	36,5	-	1,34	PHP 33-8M-85TB
34	86,58	85,22	95	6F	1615	14	42	95	28,5	38	28,5	-	1,43	PHP 34-8M-85TB
35	89,13	87,75	95	6F	1615	14	42	95	28,5	38	28,5	-	1,54	PHP 35-8M-85TB
36	91,67	90,30	100	6F	1615	14	42	95	28,5	38	28,5	-	1,87	PHP 36-8M-85TB
38	96,77	95,39	106	6F	1615	14	42	95	28,5	38	28,5	-	2,20	PHP 38-8M-85TB
40	101,86	100,49	110	6F	2012	14	50	95	31,5	32	31,5	-	1,80	PHP 40-8M-85TB
42	106,95	105,58	110	6F	2012	14	50	95	31,5	32	31,5	-	2,16	PHP 42-8M-85TB
44	112,05	110,67	121	6F	2012	14	50	95	31,5	32	31,5	-	2,30	PHP 44-8M-85TB
45	114,59	113,22	121	6F	2012	14	50	95	31,5	32	31,5	-	2,39	PHP 45-8M-85TB
48	122,23	120,86	131	6F	2517	16	60	95	25,0	45	25,0	-	2,66	PHP 48-8M-85TB
50	127,32	125,95	131	6F	2517	16	60	95	25,0	45	25,0	-	3,11	PHP 50-8M-85TB
52	132,42	131,04	140	6F	2517	16	60	95	25,0	45	25,0	-	3,56	PHP 52-8M-85TB
56	142,60	141,23	151	6F	2517	16	60	95	25,0	45	25,0	-	4,45	PHP 56-8M-85TB
58	147,70	146,32	158	6F	2517	16	60	95	25,0	45	25,0	-	4,89	PHP 58-8M-85TB
60	152,79	151,42	158	6F	2517	16	60	95	25,0	45	25,0	-	5,33	PHP 60-8M-85TB
64	162,97	161,60	171	7F	2517	16	60	95	25,0	45	25,0	-	6,20	PHP 64-8M-85TB
72	183,35	181,97	192	7	3020	25	75	95	22,0	51	22,0	-	8,00	PHP 72-8M-85TB
80	203,72	202,35	-	8	3020	25	75	95	22,0	51	22,0	-	10,00	PHP 80-8M-85TB
90	229,18	227,81	-	8	3020	25	75	95	22,0	51	22,0	-	10,80	PHP 90-8M-85TB
112	285,21	283,83	-	8	3020	25	75	95	22,0	51	22,0	170	15,00	PHP 112-8M-85TB
144	366,69	365,32	-	8	3535	35	90	95	3,0	89	3,0	190	20,00	PHP 144-8M-85TB
168	427,81	426,44	-	8	3535	35	90	95	3,0	89	3,0	190	23,00	PHP 168-8M-85TB
192	488,92	487,55	-	8	3535	35	90	95	3,0	89	3,0	190	28,50	PHP 192-8M-85TB



HiTD pulleys

Taper bushed

- ▶ Belts
- ▶ Chains
- ▶ Couplings
- ▶ Bushings and Hubs
- ▶ Sprockets
- ▶ Pulleys
- ▶ Smart tools

14 mm Pitch

Type 6F

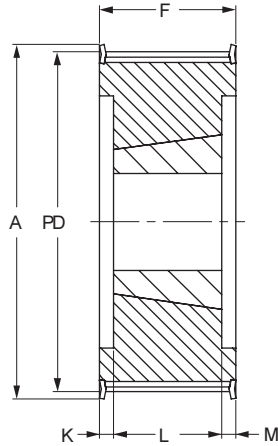

Type 7

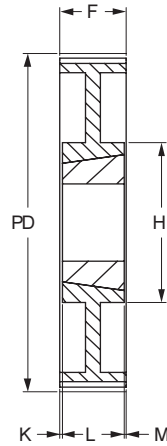

Type 7F

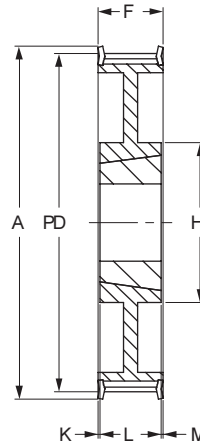

Type 8

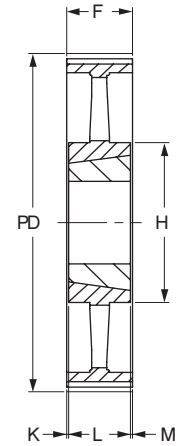

Belt Width 40 mm

No. Teeth	Diameter			Type	Bush No.	Bore		Dimensions					Weight kg	Designation
	P.D.	O.D.	A			Min	Max	F	K	L	M	H		
	mm	mm	mm			mm	mm	mm	mm	mm	mm	mm		
28	124,78	122,12	141	6F	2012	14	50	54	11,0	32	11,0	-	2,66	PHP 28-14M-40TB
29	129,23	126,57	141	6F	2012	14	50	54	11,0	32	11,0	-	2,66	PHP 29-14M-40TB
30	133,69	130,99	156	6F	2012	14	50	54	11,0	32	11,0	-	2,89	PHP 30-14M-40TB
32	142,60	139,88	156	6F	2012	14	50	54	11,0	32	11,0	-	3,51	PHP 32-14M-40TB
34	151,52	148,79	165	6F	2517	16	60	54	4,5	45	4,5	-	3,87	PHP 34-14M-40TB
35	155,97	153,18	173	6F	2517	16	60	54	4,5	45	4,5	-	4,34	PHP 35-14M-40TB
36	160,43	157,68	173	6F	2517	16	60	54	4,5	45	4,5	-	4,62	PHP 36-14M-40TB
38	169,34	166,60	182	6F	2517	16	60	54	4,5	45	4,5	-	5,40	PHP 38-14M-40TB
40	178,25	175,49	191	6F	2517	16	60	54	4,5	45	4,5	-	6,23	PHP 40-14M-40TB
42	187,17	184,37	209	6F	2517	16	60	54	4,5	45	4,5	-	6,75	PHP 42-14M-40TB
44	196,08	193,28	209	6F	3020	25	75	54	1,5	51	1,5	-	7,26	PHP 44-14M-40TB
45	200,54	197,74	227	6F	3020	25	75	54	1,5	51	1,5	-	8,20	PHP 45-14M-40TB
48	213,90	211,11	227	6F	3020	25	75	54	1,5	51	1,5	-	9,33	PHP 48-14M-40TB
50	222,82	220,02	246	6F	3020	25	75	54	1,5	51	1,5	-	10,10	PHP 50-14M-40TB
56	249,55	246,76	264	6F	3020	25	75	54	1,5	51	1,5	-	10,80	PHP 56-14M-40TB
60	267,38	264,59	281	7F	3020	25	75	54	1,5	51	1,5	170	13,10	PHP 60-14M-40TB
64	285,21	282,41	296	7F	3020	25	75	54	1,5	51	1,5	170	15,40	PHP 64-14M-40TB
72	320,86	318,06	-	7	3020	25	75	54	1,5	51	1,5	170	19,75	PHP 72-14M-40TB
80	356,51	353,71	-	8	3020	25	75	54	1,5	51	1,5	170	20,00	PHP 80-14M-40TB
90	401,07	398,28	-	8	3020	25	75	54	1,5	51	1,5	170	21,80	PHP 90-14M-40TB
112	499,11	496,32	-	8	3020	25	75	54	1,5	51	1,5	170	29,60	PHP 112-14M-40TB
144	641,71	638,92	-	8	3020	25	75	54	1,5	51	1,5	170	36,00	PHP 144-14M-40TB
168	748,66	745,87	-	8	3020	25	75	54	1,5	51	1,5	170	48,00	PHP 168-14M-40TB
192	855,62	852,82	-	8	3020	25	75	54	1,5	51	1,5	170	53,00	PHP 192-14M-40TB
216	962,56	960,00	-	8	3020	25	75	54	1,5	51	1,5	170	60,00	PHP 216-14M-40TB



HiTD pulleys

Taper bushed



14 mm Pitch

Type 6F

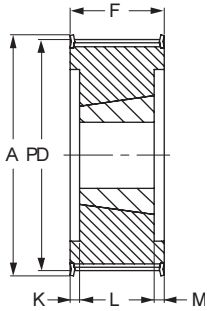

Type 7

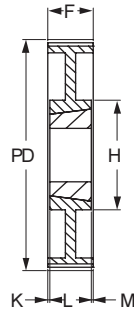

Type 7F

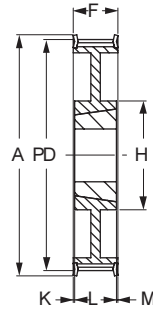

Type 8

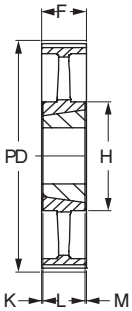

Type 10

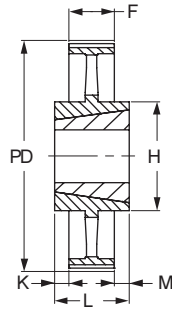

Belt Width 55 mm

No. Teeth	Diameter			Type	Bush No.	Bore		Dimensions					Weight	Designation
	P.D.	O.D.	A			Min	Max	F	K	L	M	H		
	mm	mm	mm			mm	mm	mm	mm	mm	mm	mm		
28	124,78	122,12	141	6F	2012	14	50	70	19,0	32	19,0	-	2,88	PHP 28-14M-55TB
29	129,23	126,57	141	6F	2012	14	50	70	19,0	32	19,0	-	3,18	PHP 29-14M-55TB
30	133,69	130,99	156	6F	2517	16	60	70	12,5	45	12,5	-	3,21	PHP 30-14M-55TB
32	142,60	139,88	156	6F	2517	16	60	70	12,5	45	12,5	-	3,90	PHP 32-14M-55TB
34	151,51	148,79	165	6F	2517	16	60	70	12,5	45	12,5	-	4,55	PHP 34-14M-55TB
35	155,97	153,18	173	6F	2517	16	60	70	12,5	45	12,5	-	4,88	PHP 35-14M-55TB
36	160,43	157,68	173	6F	2517	16	60	70	12,5	45	12,5	-	5,20	PHP 36-14M-55TB
38	169,34	166,60	182	6F	2517	16	60	70	12,5	45	12,5	-	6,20	PHP 38-14M-55TB
40	178,25	175,49	191	6F	2517	16	60	70	12,5	45	12,5	-	7,00	PHP 40-14M-55TB
42	187,17	184,37	209	6F	3020	25	75	70	9,5	51	9,5	-	7,80	PHP 42-14M-55TB
44	196,08	193,28	209	6F	3020	25	75	70	9,5	51	9,5	-	8,42	PHP 44-14M-55TB
45	200,54	197,74	227	6F	3020	25	75	70	9,5	51	9,5	-	9,51	PHP 45-14M-55TB
48	213,90	211,11	227	6F	3020	25	75	70	9,5	51	9,5	-	10,64	PHP 48-14M-55TB
50	228,82	220,02	246	6F	3020	25	75	70	9,5	51	9,5	-	11,52	PHP 50-14M-55TB
56	249,55	246,76	264	6F	3020	25	75	70	9,5	51	9,5	-	12,40	PHP 56-14M-55TB
60	267,38	264,59	281	7F	3020	25	75	70	9,5	51	9,5	170	14,00	PHP 60-14M-55TB
64	285,21	282,41	298	7F	3020	25	75	70	9,5	51	9,5	170	15,18	PHP 64-14M-55TB
72	320,86	318,06	-	7	3020	25	75	70	9,5	51	9,5	170	20,00	PHP 72-14M-55TB
80	356,51	353,71	-	8	3020	25	75	70	9,5	51	9,5	170	22,50	PHP 80-14M-55TB
90	401,07	398,28	-	8	3020	25	75	70	9,5	51	9,5	170	25,00	PHP 90-14M-55TB
112	499,11	496,32	-	8	3020	25	75	70	9,5	51	9,5	170	33,40	PHP 112-14M-55TB
144	641,71	638,92	-	8	3020	25	75	70	9,5	51	9,5	170	46,50	PHP 144-14M-55TB
168	748,66	745,87	-	8	3020	25	75	70	9,5	51	9,5	170	58,50	PHP 168-14M-55TB
192	855,62	852,82	-	8	3020	25	75	70	9,5	51	9,5	170	62,00	PHP 192-14M-55TB
216	962,56	960,00	-	10	3535	35	90	70	9,5	51	9,5	190	74,80	PHP 216-14M-55TB



HiTD pulleys

Taper bushed

- ▶ Belts
- ▶ Chains
- ▶ Couplings
- ▶ Bushings and Hubs
- ▶ Sprockets
- ▶ Pulleys
- ▶ Smart tools

14 mm Pitch

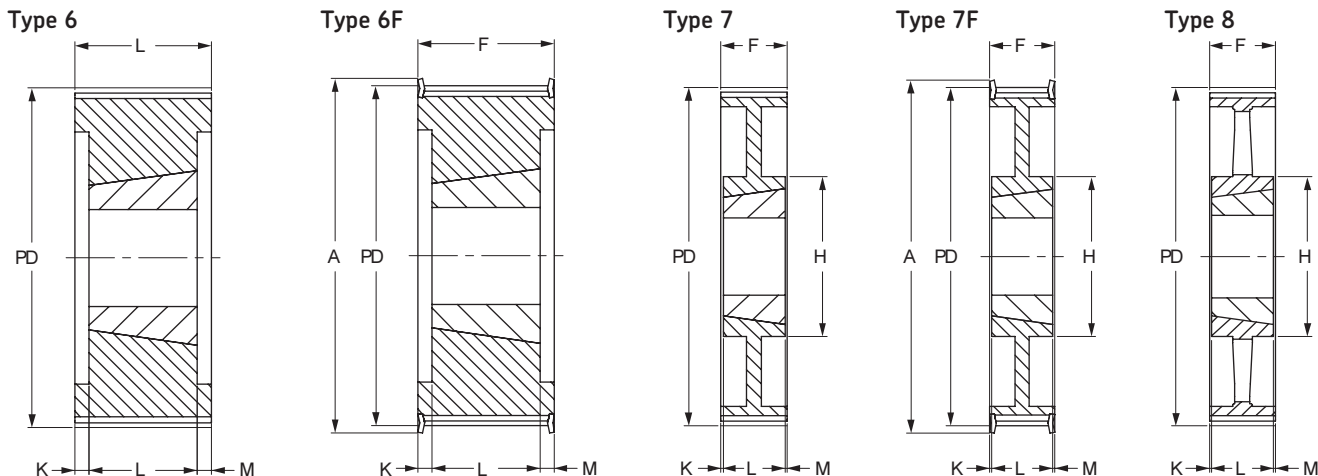

Belt Width 85 mm

No. Teeth	Diameter			Type	Bush No.	Bore		Dimensions					Weight kg	Designation
	P.D.	O.D.	A			Min	Max	F	K	L	M	H		
	mm	mm	mm			mm	mm	mm	mm	mm	mm	mm		
28	124,78	122,12	141	6F	2517	16	60	102	28,5	45	28,5	-	2,70	PHP 28-14M-85TB
29	129,23	126,57	141	6F	2517	16	60	102	28,5	45	28,5	-	3,40	PHP 29-14M-85TB
30	133,69	130,99	156	6F	2517	16	60	102	28,5	45	28,5	-	3,75	PHP 30-14M-85TB
32	142,60	139,88	156	6F	2517	16	60	102	28,5	45	28,5	-	4,80	PHP 32-14M-85TB
34	151,51	148,79	165	6F	2517	16	60	102	28,5	45	28,5	-	6,00	PHP 34-14M-85TB
35	155,97	153,18	173	6F	2517	16	75	102	25,5	51	25,5	-	6,33	PHP 35-14M-85TB
36	160,43	157,68	173	6F	3020	25	75	102	25,5	51	25,5	-	6,67	PHP 36-14M-85TB
38	169,34	166,60	182	6F	3020	25	75	102	25,5	51	25,5	-	6,80	PHP 38-14M-85TB
40	178,25	175,49	191	6F	3020	25	75	102	25,5	51	25,5	-	8,00	PHP 40-14M-85TB
42	181,17	184,37	209	6F	3020	25	75	102	13,0	76	13,0	-	9,90	PHP 42-14M-85TB
44	196,08	193,28	209	6F	3020	25	75	102	13,0	76	13,0	-	11,80	PHP 44-14M-85TB
45	200,54	197,74	227	6F	3020	25	75	102	13,0	76	13,0	-	12,63	PHP 45-14M-85TB
48	213,90	211,11	227	6F	3020	25	75	102	13,0	76	13,0	-	15,10	PHP 48-14M-85TB
50	222,82	220,02	246	6F	3535	35	90	102	18,5	65	18,5	-	16,08	PHP 50-14M-85TB
56	249,55	246,76	264	6F	3535	35	90	102	18,5	65	18,5	-	19,00	PHP 56-14M-85TB
60	267,38	264,59	281	6F	3535	35	90	102	18,5	65	18,5	-	21,00	PHP 60-14M-85TB
64	285,21	282,41	298	7F	3535	35	90	102	18,5	65	18,5	190	23,00	PHP 64-14M-85TB
72	320,86	318,06	-	7	3535	35	90	102	18,5	65	18,5	190	25,00	PHP 72-14M-85TB
80	356,51	353,71	-	8	3535	35	90	102	18,5	65	18,5	190	26,00	PHP 80-14M-85TB
90	401,07	398,28	-	8	3535	35	90	102	18,5	65	18,5	190	27,80	PHP 90-14M-85TB
112	499,11	496,32	-	8	3535	35	90	102	18,5	65	18,5	190	36,50	PHP 112-14M-85TB
144	641,71	638,92	-	8	4040	40	100	102	18,5	65	18,5	230	48,00	PHP 144-14M-85TB
168	748,66	745,87	-	8	4040	40	100	102	18,5	65	18,5	230	60,00	PHP 168-14M-85TB
192	855,62	852,82	-	8	4040	40	100	102	-	102	-	230	86,00	PHP 192-14M-85TB
216	962,56	960,00	-	8	4040	40	100	102	-	102	-	230	119,50	PHP 216-14M-85TB



HiTD pulleys

Taper bushed



14 mm Pitch

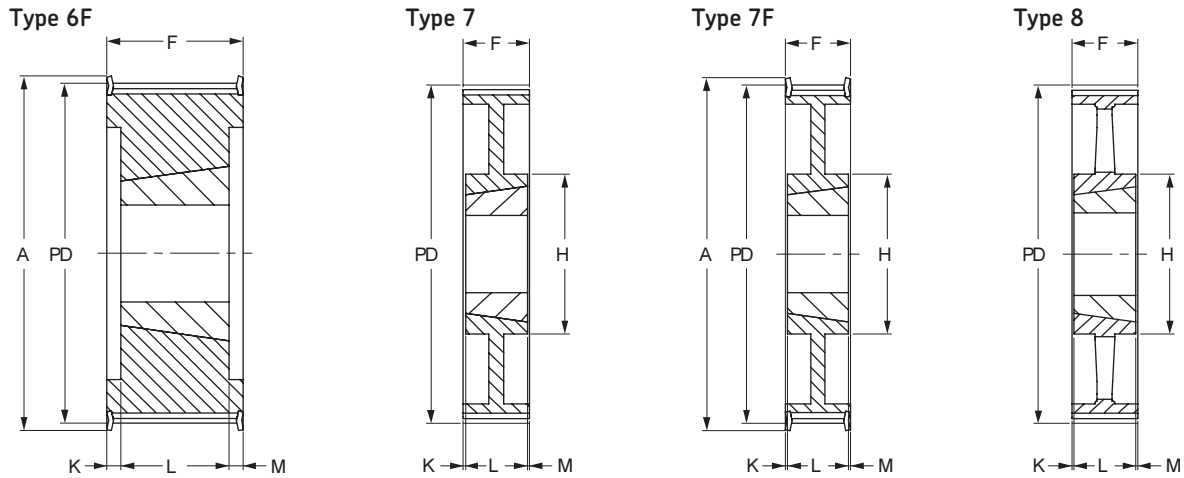

Belt Width 115 mm

No. Teeth	Diameter			Type	Bush No.	Bore		Dimensions					Weight kg	Designation
	P.D.	O.D.	A			Min	Max	F	K	L	M	H		
	mm	mm	mm			mm	mm	mm	mm	mm	mm	mm		
28	124,78	122,12	141	6F	2517	16	60	133	44,0	45	44,0	-	3,77	PHP 28-14M-115TB
29	129,23	126,57	141	6F	2517	16	60	133	44,0	45	44,0	-	4,00	PHP 29-14M-115TB
30	133,69	130,99	156	6F	2517	16	60	133	44,0	45	44,0	-	5,00	PHP 30-14M-115TB
32	142,60	139,88	156	6F	2517	16	60	133	44,0	45	44,0	-	6,00	PHP 32-14M-115TB
34	151,52	148,79	165	6F	2517	16	60	133	44,0	45	44,0	-	7,20	PHP 34-14M-115TB
35	155,97	153,18	173	6F	3020	25	75	133	41,0	51	41,0	-	7,00	PHP 35-14M-115TB
36	160,43	157,68	173	6F	3020	25	75	133	41,0	51	41,0	-	7,30	PHP 36-14M-115TB
38	169,34	166,60	182	6F	3020	25	75	133	41,0	51	41,0	-	8,40	PHP 38-14M-115TB
40	178,25	175,49	191	6F	3020	25	75	133	41,0	51	41,0	-	9,20	PHP 40-14M-115TB
42	187,17	184,37	209	6F	3030	35	75	133	28,5	76	28,5	-	11,60	PHP 42-14M-115TB
44	196,08	193,28	209	6F	3030	35	75	133	28,5	76	28,5	-	14,00	PHP 44-14M-115TB
45	200,54	197,74	227	6F	3030	35	75	133	28,5	76	28,5	-	15,60	PHP 45-14M-115TB
48	213,90	211,11	227	6F	3030	35	75	133	28,5	76	28,5	-	17,10	PHP 48-14M-115TB
50	222,82	220,02	246	6F	3535	35	90	133	22,0	89	22,0	-	21,00	PHP 50-14M-115TB
56	249,55	246,76	264	6F	3535	35	90	133	22,0	89	22,0	-	24,80	PHP 56-14M-115TB
60	267,38	264,59	281	6F	3535	35	90	133	22,0	89	22,0	-	25,90	PHP 60-14M-115TB
64	285,21	282,41	298	7F	3535	35	90	133	22,0	89	22,0	190	27,00	PHP 64-14M-115TB
72	320,86	318,06	-	7	3535	35	90	133	22,0	89	22,0	190	33,00	PHP 72-14M-115TB
80	356,51	353,71	-	7	3535	35	90	133	22,0	89	22,0	190	37,00	PHP 80-14M-115TB
90	401,07	398,28	-	7	3535	35	90	133	22,0	89	22,0	190	42,00	PHP 90-14M-115TB
112	499,11	496,32	-	8	3535	35	90	133	22,0	89	22,0	190	56,00	PHP 112-14M-115TB
144	641,71	638,92	-	8	4040	40	100	133	15,5	102	15,5	230	75,00	PHP 144-14M-115TB
168	748,66	745,87	-	8	4040	40	100	133	15,5	102	15,5	230	92,60	PHP 168-14M-115TB
192	855,62	852,92	-	8	4040	40	100	133	15,5	102	15,5	230	230,00	PHP 192-14M-115TB
216	962,57	959,76	-	8	4040	40	100	133	15,5	102	15,5	230	127,00	PHP 216-14M-115TB



HiTD pulleys

Taper bushed

- ▶ Belts
- ▶ Chains
- ▶ Couplings
- ▶ Bushings and Hubs
- ▶ Sprockets
- ▶ Pulleys
- ▶ Smart tools

14 mm Pitch

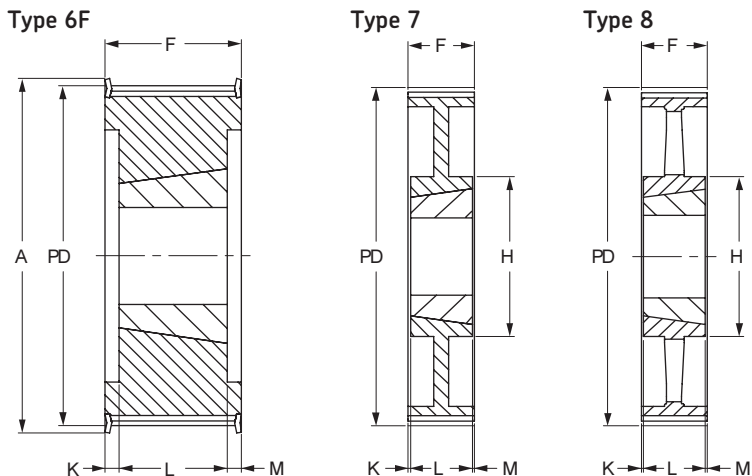

Belt Width 170 mm

No. Teeth	Diameter			Type	Bush No.	Bore		Dimensions					Weight kg	Designation
	P.D.	O.D.	A			Min	Max	F	K	L	M	H		
	mm	mm	mm			mm	mm	mm	mm	mm	mm	mm		
35	155,97	153,18	173	6F	3030	35	75	187	55,5	76	55,5	-	10,60	PHP 35-14M-170TB
36	160,43	157,68	173	6F	3030	35	75	187	55,5	76	55,5	-	11,20	PHP 36-14M-170TB
38	169,34	167,00	182	6F	3030	35	75	187	55,5	76	55,5	-	11,70	PHP 38-14M-170TB
40	178,25	175,00	191	6F	3030	35	75	187	55,5	76	55,5	-	13,00	PHP 40-14M-170TB
42	187,17	184,37	202	6F	3535	35	90	187	49,0	89	49,0	-	14,00	PHP 42-14M-170TB
44	196,08	193,00	209	6F	3535	35	90	187	49,0	89	49,0	-	15,00	PHP 44-14M-170TB
45	200,54	197,74	212	6F	3535	35	90	187	49,0	89	49,0	-	16,00	PHP 45-14M-170TB
48	213,90	211,00	227	6F	3535	35	90	187	49,0	89	49,0	-	19,00	PHP 48-14M-170TB
50	222,82	220,02	246	6F	3535	35	90	187	49,0	89	49,0	-	23,80	PHP 50-14M-170TB
56	249,55	247,00	263	6F	3535	35	90	187	49,0	89	49,0	-	28,50	PHP 56-14M-170TB
60	267,38	264,59	281	6F	4040	40	100	187	42,5	114	42,5	-	34,80	PHP 60-14M-170TB
64	285,21	282,00	298	6F	4040	40	100	187	42,5	114	42,5	230	41,00	PHP 64-14M-170TB
72	320,86	318,00	-	7	4040	40	100	187	42,5	114	42,5	230	46,90	PHP 72-14M-170TB
80	356,51	354,00	-	7	4040	40	100	187	42,5	114	42,5	230	48,00	PHP 80-14M-170TB
90	401,07	398,00	-	7	4040	40	100	187	42,5	114	42,5	230	52,50	PHP 90-14M-170TB
112	499,11	496,00	-	7	5050	70	125	187	30,0	127	30,0	242	74,50	PHP 112-14M-170TB
144	641,71	639,00	-	8	5050	70	125	187	30,0	127	30,0	394	91,00	PHP 144-14M-170TB
168	748,86	746,00	-	8	5050	70	125	187	30,0	127	30,0	394	116,00	PHP 168-14M-170TB
192	855,62	853,00	-	8	5050	70	125	187	30,0	127	30,0	394	134,00	PHP 192-14M-170TB
216	962,57	960,00	-	8	5050	70	125	187	30,0	127	30,0	394	146,50	PHP 216-14M-170TB



Classical timing pulleys

Pilot bore (RSB)



XL

1/5" Pitch (5,08 mm)

Type 1

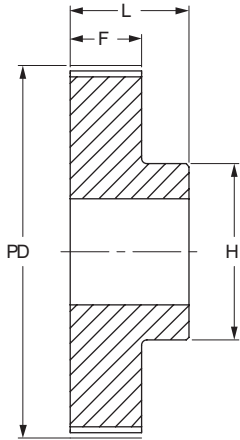

Type 1F

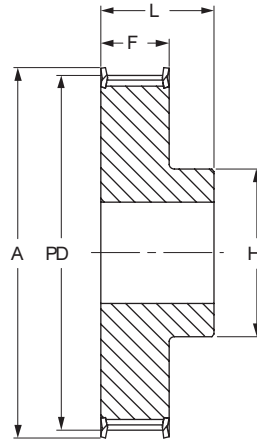

XL 037

For Belt Width 6,4 mm and 9,5 mm

No. Teeth	Diameter			Type	Bore		Dimensions			Weight kg	Designation
	P.D.	O.D.	A		Min	Max	H	F	L		
	mm	mm	mm		mm	mm	mm	mm	mm		
10	16,17	15,67	23	1F	5	5	9,5	14,3	19,8	0,02	PHP 10XL037RSB
11	17,79	17,29	23	1F	5	5	9,5	14,3	19,8	0,02	PHP 11XL037RSB
12	19,40	18,90	25	1F	5	8	12,7	14,3	19,8	0,03	PHP 12XL037RSB
13	21,02	20,52	25	1F	6	8	12,7	14,3	19,8	0,03	PHP 13XL037RSB
14	22,64	22,14	28	1F	6	9	14,3	14,3	19,8	0,04	PHP 14XL037RSB
15	24,26	23,76	28	1F	6	11	15,9	14,3	19,8	0,04	PHP 15XL037RSB
16	25,87	25,37	32	1F	6	12	17,5	14,3	19,8	0,05	PHP 16XL037RSB
17	27,49	26,99	36	1F	6	13	20,0	14,3	19,8	0,05	PHP 17XL037RSB
18	29,11	28,61	36	1F	6	13	20,6	14,3	19,8	0,06	PHP 18XL037RSB
19	30,72	30,22	36	1F	6	13	20,6	14,3	19,8	0,07	PHP 19XL037RSB
20	32,34	31,84	38	1F	6	15	23,8	14,3	22,2	0,08	PHP 20XL037RSB
21	33,96	33,46	38	1F	6	15	23,8	14,3	22,2	0,09	PHP 21XL037RSB
22	35,57	35,07	42	1F	6	16	25,4	14,3	22,2	0,10	PHP 22XL037RSB
24	38,81	38,31	44	1F	6	18	27,0	14,3	22,2	0,12	PHP 24XL037RSB
26	42,04	41,54	48	1F	6	20	30,0	14,3	22,2	0,14	PHP 26XL037RSB
27	43,66	43,16	48	1F	6	20	30,0	14,3	22,2	0,15	PHP 27XL037RSB
28	45,28	44,78	51	1F	6	20	30,2	14,3	22,2	0,16	PHP 28XL037RSB
29	46,89	46,39	51	1F	6	20	30,2	14,3	22,2	0,17	PHP 29XL037RSB
30	48,51	48,01	54	1F	6	24	34,9	14,3	22,2	0,19	PHP 30XL037RSB
32	51,74	51,24	57	1	8	25	40,0	14,3	25,4	0,11	PHP 32XL037RSB
34	54,98	54,48	-	1	8	25	38,0	14,3	25,4	0,11	PHP 34XL037RSB
35	56,60	56,10	-	1	8	25	38,0	14,3	25,4	0,12	PHP 35XL037RSB
36	58,21	57,71	-	1	8	30	45,0	14,3	25,4	0,13	PHP 36XL037RSB
38	61,45	60,95	-	1	8	30	45,0	14,3	25,4	0,15	PHP 38XL037RSB
40	64,68	64,18	-	1	8	30	45,0	14,3	25,4	0,17	PHP 40XL037RSB
42	67,91	67,41	-	1	8	30	45,0	14,3	25,4	0,20	PHP 42XL037RSB
44	71,15	70,65	-	1	8	30	45,0	14,3	25,4	0,15	PHP 44XL037RSB
45	72,77	72,27	-	1	8	30	45,0	14,3	25,4	0,15	PHP 45XL037RSB
48	77,62	77,12	-	1	8	30	45,0	14,3	25,4	0,16	PHP 48XL037RSB
60	97,02	96,52	-	1	8	30	45,0	14,3	25,4	0,18	PHP 60XL037RSB
72	116,43	115,93	-	1	8	30	45,0	14,3	25,4	0,23	PHP 72XL037RSB

All pulleys are Aluminium with 2 set screws at 90°. Where keyway is required, reduce maximum bore by twice keyway depth.



Classical timing pulleys

Pilot bore (RSB)

- ▶ Belts
- ▶ Chains
- ▶ Couplings
- ▶ Bushings and Hubs
- ▶ Sprockets
- ▶ Pulleys
- ▶ Smart tools

L 3/8" Pitch (9,525 mm)

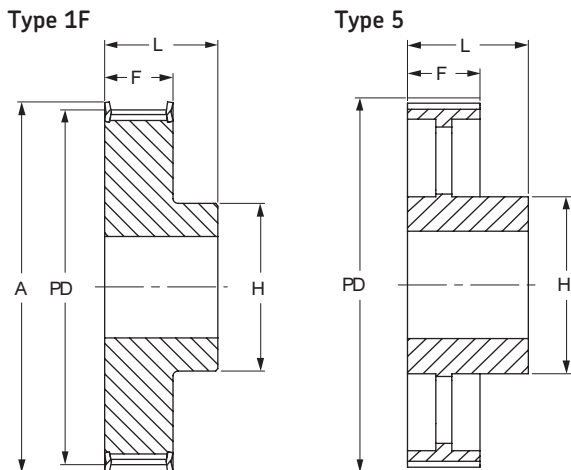

L 050

For Belt Width 12,7 mm

No. Teeth	Diameter			Type	Bore		Dimensions			Weight kg	Designation
	P.D.	O.D.	A		Min	Max	H	F	L		
	mm	mm	mm		mm	mm	mm	mm	mm		
10	30,32	29,56	36	1F	6	14	22	19	26	0,11	PHP 10L050RSB
11	33,35	32,59	39	1F	6	14	22	19	26	0,13	PHP 11L050RSB
12	36,38	35,62	42	1F	6	20	28	19	30	0,19	PHP 12L050RSB
13	39,41	38,65	45	1F	6	20	28	19	30	0,21	PHP 13L050RSB
14	42,45	41,69	48	1F	8	20	28	19	30	0,23	PHP 14L050RSB
15	45,48	44,72	51	1F	8	23	32	19	30	0,27	PHP 15L050RSB
16	48,51	47,75	54	1F	8	24	36	19	32	0,34	PHP 16L050RSB
17	51,54	50,78	57	1F	10	24	38	19	32	0,38	PHP 17L050RSB
18	54,57	53,81	60	1F	10	27	40	19	32	0,41	PHP 18L050RSB
19	57,61	56,85	63	1F	10	27	40	19	32	0,45	PHP 19L050RSB
20	60,64	59,88	66	1F	10	30	46	19	32	0,50	PHP 20L050RSB
21	63,67	62,91	69	1F	10	30	46	19	32	0,55	PHP 21L050RSB
22	66,70	65,94	72	1F	10	33	50	19	32	0,62	PHP 22L050RSB
23	69,73	68,97	78	1F	10	33	50	19	26	0,65	PHP 23L050RSB
24	72,77	72,01	78	1F	12	33	50	19	26	0,68	PHP 24L050RSB
25	75,80	75,04	85	1F	12	33	50	19	26	0,74	PHP 25L050RSB
26	78,83	78,07	85	1F	12	33	50	19	26	0,82	PHP 26L050RSB
27	81,86	81,10	91	1F	12	33	50	19	26	0,85	PHP 27L050RSB
28	84,89	84,13	91	1F	12	33	50	19	26	0,92	PHP 28L050RSB
29	87,93	87,17	91	1F	12	33	50	19	26	1,00	PHP 29L050RSB
30	90,96	90,20	97	1F	12	33	50	19	26	1,10	PHP 30L050RSB
31	93,99	93,23	103	1F	12	33	50	19	26	1,14	PHP 31L050RSB
32	97,02	96,26	103	1F	12	33	50	19	26	1,19	PHP 32L050RSB
33	100,05	99,29	106	1F	12	33	50	19	26	1,25	PHP 33L050RSB
34	103,08	102,32	115	1F	12	33	50	19	26	1,31	PHP 34L050RSB
35	106,12	105,36	115	1F	12	33	50	19	26	1,37	PHP 35L050RSB
36	109,15	108,39	115	1F	12	33	50	19	26	1,10	PHP 36L050RSB
38	115,21	114,45	127	1F	12	33	50	19	26	1,22	PHP 38L050RSB
40	121,28	120,52	127	1F	12	33	50	19	26	1,26	PHP 40L050RSB
42	127,34	126,58	139	1F	12	33	50	19	26	1,31	PHP 42L050RSB
44	133,40	132,64	139	1F	12	33	50	19	28	1,43	PHP 44L050RSB
45	136,44	135,68	152	1F	12	33	50	19	28	1,49	PHP 45L050RSB
48	145,53	144,77	152	1F	12	33	50	19	28	1,55	PHP 48L050RSB
50	151,60	150,84	-	5	12	33	50	19	28	1,66	PHP 50L050RSB
52	157,66	156,90	-	5	12	33	50	19	28	1,85	PHP 52L050RSB
56	169,79	169,03	-	5	12	33	50	19	28	1,97	PHP 56L050RSB
57	172,82	172,06	-	5	12	33	50	19	28	2,09	PHP 57L050RSB
60	191,91	191,15	-	5	15	45	50	19	42	2,30	PHP 60L050RSB
72	218,30	217,54	-	5	15	45	75	19	42	2,50	PHP 72L050RSB
76	230,43	229,67	-	5	15	45	75	19	42	2,70	PHP 76L050RSB
84	254,68	253,92	-	5	15	45	75	19	42	2,90	PHP 84L050RSB
95	283,03	282,27	-	5	15	45	75	19	42	3,10	PHP 95L050RSB
96	291,06	290,30	-	5	15	45	75	19	42	3,30	PHP 96L050RSB



Classical timing pulleys

Pilot bore (RSB)



L 3/8" Pitch (9,525 mm)

Type 1F

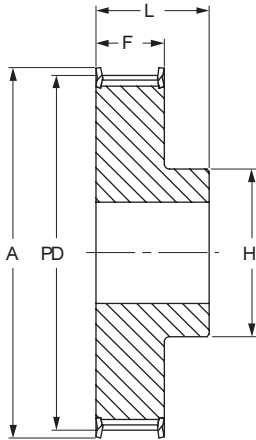

Type 5

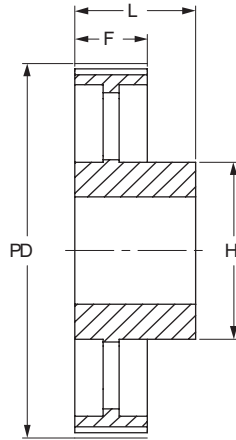

L 050

For Belt Width 19,1 mm

No. Teeth	Diameter			Type	Bore		Dimensions			Weight kg	Designation
	P.D.	O.D.	A		Min	Max	H	F	L		
	mm	mm	mm		mm	mm	mm	mm	mm		
10	30,32	29,56	36	1F	6	14	22	25,4	32	0,15	PHP 10L075RSB
11	33,35	32,59	39	1F	6	14	22	25,4	32	0,20	PHP 11L075RSB
12	36,38	35,62	42	1F	8	20	28	25,4	38	0,23	PHP 12L075RSB
13	39,41	38,65	45	1F	8	20	28	25,4	38	0,26	PHP 13L075RSB
14	42,45	41,69	48	1F	8	20	28	25,4	38	0,28	PHP 14L075RSB
15	45,48	44,72	51	1F	8	23	32	25,4	38	0,36	PHP 15L075RSB
16	48,51	47,75	54	1F	8	24	36	25,4	41	0,45	PHP 16L075RSB
17	51,54	50,78	57	1F	10	24	38	25,4	41	0,50	PHP 17L075RSB
18	54,57	53,81	60	1F	10	27	40	25,4	41	0,55	PHP 18L075RSB
19	57,61	56,85	63	1F	10	27	40	25,4	41	0,60	PHP 19L075RSB
20	60,64	59,88	66	1F	10	30	46	25,4	41	0,65	PHP 20L075RSB
21	63,67	62,91	69	1F	10	30	46	25,4	41	0,70	PHP 21L075RSB
22	66,70	65,94	72	1F	10	33	50	25,4	41	0,75	PHP 22L075RSB
23	69,73	68,97	78	1F	10	33	50	25,4	32	0,81	PHP 23L075RSB
24	72,77	72,01	79	1F	12	33	50	25,4	32	0,85	PHP 24L075RSB
25	75,80	75,04	85	1F	12	33	50	25,4	32	0,94	PHP 25L075RSB
26	78,83	78,07	85	1F	12	33	50	25,4	32	1,02	PHP 26L075RSB
27	81,86	81,10	91	1F	12	33	50	25,4	32	1,09	PHP 27L075RSB
28	84,89	84,13	91	1F	12	33	50	25,4	32	1,20	PHP 28L075RSB
29	87,93	87,17	91	1F	12	33	50	25,4	32	1,33	PHP 29L075RSB
30	90,96	90,20	97	1F	12	33	50	25,4	32	1,33	PHP 30L075RSB
31	93,99	93,23	103	1F	12	33	50	25,4	32	1,39	PHP 31L075RSB
32	97,02	96,26	103	1F	12	33	50	25,4	32	1,45	PHP 32L075RSB
33	100,05	99,29	106	1F	12	33	50	25,4	32	1,56	PHP 33L075RSB
34	103,08	102,32	115	1F	12	33	50	25,4	32	1,70	PHP 34L075RSB
35	106,12	105,36	115	1F	12	33	50	25,4	32	1,78	PHP 35L075RSB
36	109,15	108,39	115	1F	12	36	55	25,4	32	1,50	PHP 36L075RSB
38	115,21	114,45	127	1F	12	36	55	25,4	32	1,63	PHP 38L075RSB
40	121,28	120,52	127	1F	12	40	60	25,4	32	1,79	PHP 40L075RSB
42	127,34	126,58	139	1F	12	40	60	25,4	32	1,95	PHP 42L075RSB
44	133,40	132,64	139	1F	12	40	60	25,4	35	2,05	PHP 44L075RSB
45	136,44	135,68	152	1F	12	40	60	25,4	35	2,10	PHP 45L075RSB
48	145,53	144,77	152	1F	12	40	60	25,4	35	2,15	PHP 48L075RSB
50	151,60	150,84	-	5	12	40	60	25,4	35	2,25	PHP 50L075RSB
52	157,66	156,90	-	5	12	40	60	25,4	35	2,55	PHP 52L075RSB
56	169,79	169,03	-	5	12	40	60	25,4	35	2,78	PHP 56L075RSB
57	172,82	172,06	-	5	12	40	60	25,4	35	2,91	PHP 57L075RSB
60	181,91	181,15	-	5	15	45	75	25,4	45	3,10	PHP 60L075RSB
72	218,30	217,54	-	5	15	45	75	25,4	45	3,29	PHP 72L075RSB
76	230,43	229,67	-	5	15	45	75	25,4	45	3,48	PHP 76L075RSB
84	254,67	253,91	-	5	15	45	75	25,4	45	3,67	PHP 84L075RSB
95	283,03	282,27	-	5	15	45	75	25,4	45	3,76	PHP 95L075RSB
96	291,06	290,30	-	5	15	45	75	25,4	45	3,85	PHP 96L075RSB
120	363,83	363,07	-	5	15	70	120	25,4	45	4,50	PHP 120L075RSB



Classical timing pulleys

Pilot bore (RSB)

- ▶ Belts
- ▶ Chains
- ▶ Couplings
- ▶ Bushings and Hubs
- ▶ Sprockets
- ▶ Pulleys
- ▶ Smart tools

L

3/8" Pitch (9,525 mm)

Type 1F

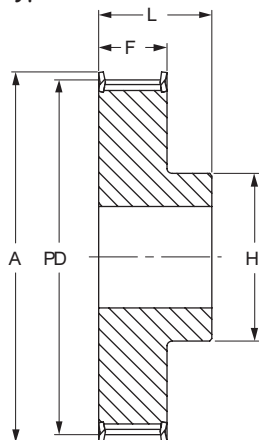

Type 5

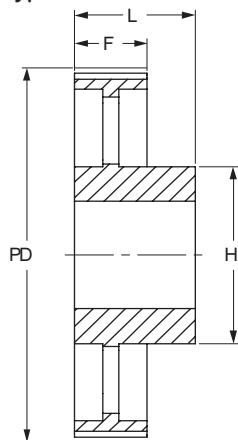

L 100

For Belt Width 25,4 mm

No. Teeth	Diameter			Type	Bore		Dimensions			Weight kg	Designation
	P.D.	O.D.	A		Min	Max	H	F	L		
	mm	mm	mm		mm	mm	mm	mm	mm		
10	30,32	29,56	36	1F	6	14	22	32	38	0,18	PHP 10L100RSB
11	33,35	32,59	39	1F	6	14	22	32	38	0,20	PHP 11L100RSB
12	36,38	35,62	42	1F	8	20	28	32	45	0,25	PHP 12L100RSB
13	39,41	38,65	45	1F	8	20	28	32	45	0,30	PHP 13L100RSB
14	42,45	41,69	48	1F	8	20	28	32	45	0,34	PHP 14L100RSB
15	45,48	44,72	51	1F	8	23	32	32	45	0,40	PHP 15L100RSB
16	48,51	47,75	54	1F	8	24	36	32	45	0,48	PHP 16L100RSB
17	51,54	50,78	57	1F	10	24	38	32	45	0,57	PHP 17L100RSB
18	54,57	53,81	60	1F	10	27	40	32	45	0,62	PHP 18L100RSB
19	57,61	56,85	63	1F	10	27	40	32	45	0,69	PHP 19L100RSB
20	60,64	59,88	66	1F	10	30	46	32	45	0,76	PHP 20L100RSB
21	63,67	62,91	69	1F	10	30	46	32	45	0,82	PHP 21L100RSB
22	66,70	65,94	72	1F	10	33	50	32	45	0,92	PHP 22L100RSB
23	69,73	68,97	78	1F	10	33	50	32	38	0,98	PHP 23L100RSB
24	72,77	72,01	78	1F	12	33	50	32	38	1,06	PHP 24L100RSB
25	75,80	75,04	85	1F	12	33	50	32	38	1,14	PHP 25L100RSB
26	78,83	78,07	85	1F	12	33	50	32	38	1,24	PHP 26L100RSB
27	81,86	81,10	91	1F	12	33	50	32	38	1,33	PHP 27L100RSB
28	84,89	84,13	91	1F	12	33	50	32	38	1,40	PHP 28L100RSB
29	87,93	87,17	91	1F	12	33	50	32	38	1,70	PHP 29L100RSB
30	90,96	90,20	97	1F	12	33	50	32	38	1,70	PHP 30L100RSB
32	97,02	96,26	103	1F	12	33	50	32	38	1,80	PHP 32L100RSB
33	100,05	99,29	106	1F	12	33	50	32	38	1,92	PHP 33L100RSB
34	103,08	102,32	115	1F	12	33	50	32	38	2,09	PHP 34L100RSB
35	106,12	105,36	115	1F	12	33	50	32	38	2,19	PHP 35L100RSB
36	109,15	108,39	115	1F	12	36	55	32	32	1,50	PHP 36L100RSB
38	115,21	114,45	127	1F	12	36	55	32	32	1,77	PHP 38L100RSB
40	121,28	120,52	127	1F	12	40	60	32	32	1,90	PHP 40L100RSB
42	127,34	126,58	139	1F	12	40	60	32	32	2,11	PHP 42L100RSB
44	133,40	132,64	139	1F	12	40	60	32	35	2,30	PHP 44L100RSB
45	136,44	135,68	152	1F	12	40	60	32	35	2,40	PHP 45L100RSB
48	145,53	144,77	152	1F	12	40	60	32	35	2,49	PHP 48L100RSB
50	151,60	150,84	-	5	12	40	60	32	35	2,68	PHP 50L100RSB
52	157,66	156,90	-	5	12	40	60	32	35	2,87	PHP 52L100RSB
56	169,79	169,03	-	5	12	40	60	32	35	3,06	PHP 56L100RSB
57	172,82	172,06	-	5	12	40	60	32	35	3,25	PHP 57L100RSB
60	191,91	191,15	-	5	15	45	75	32	45	3,44	PHP 60L100RSB
72	218,30	217,54	-	5	15	45	75	32	45	3,63	PHP 72L100RSB
76	230,43	229,67	-	5	15	45	75	32	45	3,82	PHP 76L100RSB
84	254,68	253,92	-	5	15	45	75	32	45	4,01	PHP 84L100RSB
95	283,03	282,27	-	5	15	45	75	32	45	4,11	PHP 95L100RSB
96	291,06	290,30	-	5	15	45	75	32	45	4,20	PHP 96L100RSB
120	363,83	363,07	-	5	15	70	120	32	45	5,00	PHP 120L100RSB



Classical timing pulleys

Pilot bore (RSB)



H

1/2" Pitch (12,7 mm)

Type 1F

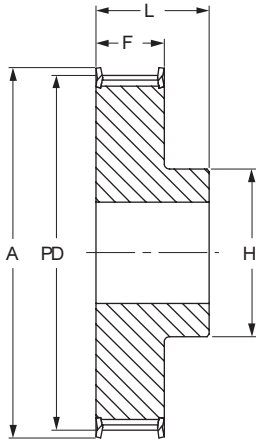

Type 5

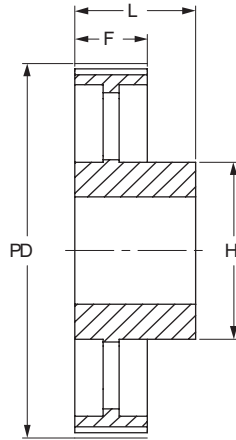

Type 5F

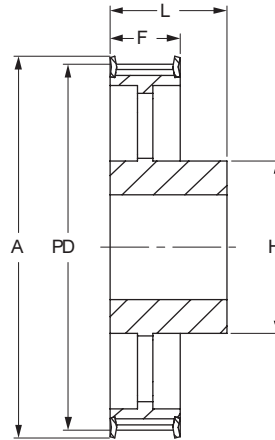

H 075

For Belt Width 19,1 mm

No. Teeth	Diameter			Type	Bore		Dimensions			Weight	Designation
	P.D.	O.D.	A		Min	Max	H	F	L		
	mm	mm	mm		mm	mm	mm	mm	mm		
14	56,60	55,23	63	1F	10	27	40	27	40	0,50	PHP 14H075RSB
15	60,64	59,27	67	1F	10	30	46	27	40	0,55	PHP 15H075RSB
16	64,68	63,31	71	1F	10	30	45	27	40	0,60	PHP 16H075RSB
17	68,72	67,35	75	1F	10	30	46	27	40	0,70	PHP 17H075RSB
18	72,77	71,40	79	1F	12	36	55	27	40	0,80	PHP 18H075RSB
19	76,81	75,44	83	1F	12	40	60	27	40	1,00	PHP 19H075RSB
20	80,85	79,48	87	1F	12	41	62	27	40	1,10	PHP 20H075RSB
21	84,89	83,52	91	1F	12	43	67	27	40	1,20	PHP 21H075RSB
22	88,94	87,57	95	1F	12	45	70	27	40	1,40	PHP 22H075RSB
23	92,98	91,61	98	1F	12	46	72	27	40	1,50	PHP 23H075RSB
24	97,02	95,65	103	1F	12	47	75	27	40	1,60	PHP 24H075RSB
25	101,06	99,69	107	1F	12	47	75	27	40	1,70	PHP 25H075RSB
26	105,11	103,74	111	1F	15	54	80	27	40	1,80	PHP 26H075RSB
27	109,15	107,78	115	1F	15	54	80	27	40	1,90	PHP 27H075RSB
28	113,19	111,82	119	1F	15	54	80	27	40	2,00	PHP 28H075RSB
29	117,23	115,86	123	1F	15	54	80	27	40	2,05	PHP 29H075RSB
30	121,28	119,91	127	1F	15	54	80	27	40	2,10	PHP 30H075RSB
31	125,32	123,95	131	1F	15	54	80	27	40	2,15	PHP 31H075RSB
32	129,36	127,99	135	1F	15	54	80	27	40	2,20	PHP 32H075RSB
33	133,40	132,03	142	1F	15	54	80	27	40	2,25	PHP 33H075RSB
34	137,45	136,08	142	1F	15	54	80	27	40	2,30	PHP 34H075RSB
35	141,49	140,12	151	1F	15	54	80	27	40	2,35	PHP 35H075RSB
36	145,53	144,16	151	1F	20	54	80	27	40	2,40	PHP 36H075RSB
38	153,62	152,25	158	1F	20	54	80	27	40	2,60	PHP 38H075RSB
40	161,70	160,33	168	1F	20	54	80	27	40	2,80	PHP 40H075RSB
42	169,79	168,42	184	1F	20	54	80	27	40	2,90	PHP 42H075RSB
44	177,87	176,50	184	5F	20	48	80	27	40	2,70	PHP 44H075RSB
45	181,91	180,54	192	5F	20	54	90	27	45	2,85	PHP 45H075RSB
48	194,04	192,67	200	5F	20	54	90	27	45	3,00	PHP 48H075RSB
50	202,13	200,76	-	5	20	54	90	27	45	3,25	PHP 50H075RSB



Classical timing pulleys

Pilot bore (RSB)

- ▶ Belts
- ▶ Chains
- ▶ Couplings
- ▶ Bushings and Hubs
- ▶ Sprockets
- ▶ Pulleys
- ▶ Smart tools

H

1/2" Pitch (12,7 mm)

Type 1F

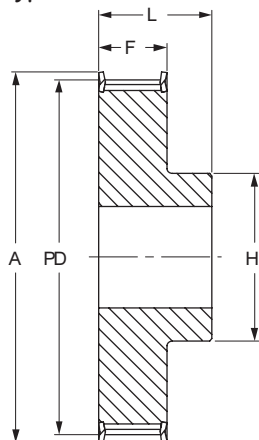

Type 5

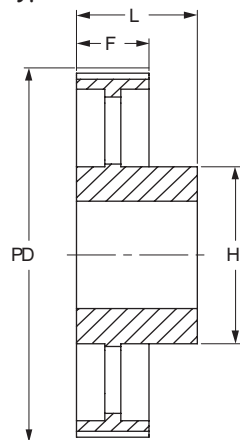

Type 5F

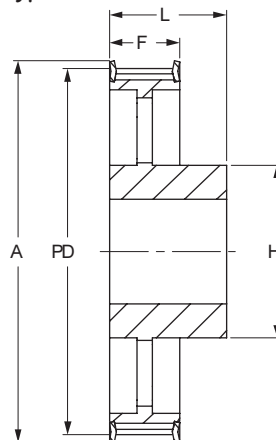

H 100

For Belt Width 19,1 mm and 25,4 mm

No. Teeth	Diameter			Type	Bore		Dimensions			Weight kg	Designation
	P.D.	O.D.	A		Min	Max	H	F	L		
	mm	mm	mm		mm	mm	mm	mm	mm		
14	56,60	55,23	63	1F	10	27	40	33,3	45	0,65	PHP 14H100RSB
15	60,64	59,27	67	1F	10	30	46	33,3	45	0,75	PHP 15H100RSB
16	64,67	63,30	71	1F	10	30	46	33,3	45	0,85	PHP 16H100RSB
17	68,72	67,35	75	1F	10	30	46	33,3	45	0,97	PHP 17H100RSB
18	72,77	71,40	79	1F	12	30	55	33,3	45	1,10	PHP 18H100RSB
19	76,81	75,44	83	1F	12	36	60	33,3	45	1,20	PHP 19H100RSB
20	80,85	79,48	87	1F	12	41	62	33,3	45	1,40	PHP 20H100RSB
21	84,89	83,52	91	1F	12	43	67	33,3	45	1,60	PHP 21H100RSB
22	88,94	87,57	95	1F	12	45	70	33,3	45	1,70	PHP 22H100RSB
23	92,98	91,61	98	1F	12	46	72	33,3	45	1,83	PHP 23H100RSB
24	97,03	95,66	103	1F	12	47	75	33,3	45	1,95	PHP 24H100RSB
25	101,06	99,69	107	1F	12	47	75	33,3	45	2,19	PHP 25H100RSB
26	105,11	103,74	111	1F	15	54	80	33,3	45	2,43	PHP 26H100RSB
27	109,15	107,78	115	1F	15	54	80	33,3	45	2,57	PHP 27H100RSB
28	113,18	111,81	119	1F	15	54	80	33,3	45	2,70	PHP 28H100RSB
29	117,23	115,86	123	1F	15	54	80	33,3	45	2,95	PHP 29H100RSB
30	121,29	119,92	127	1F	15	54	80	33,3	45	3,20	PHP 30H100RSB
31	125,32	123,95	131	1F	15	54	80	33,3	45	3,35	PHP 31H100RSB
32	129,36	127,99	135	1F	20	54	80	33,3	45	3,50	PHP 32H100RSB
33	133,40	132,03	142	1F	20	54	80	33,3	45	3,78	PHP 33H100RSB
34	137,45	136,08	142	1F	20	54	80	33,3	45	4,05	PHP 34H100RSB
35	141,49	140,12	151	1F	20	54	80	33,3	45	4,35	PHP 35H100RSB
36	145,53	144,16	151	1F	20	54	80	33,3	45	4,65	PHP 36H100RSB
38	153,62	152,25	158	1F	20	54	80	33,3	45	4,98	PHP 38H100RSB
40	161,70	160,33	168	1F	20	54	80	33,3	45	5,30	PHP 40H100RSB
42	169,79	168,42	184	1F	20	54	80	33,3	45	5,50	PHP 42H100RSB
44	177,87	176,50	184	5F	20	48	80	33,3	50	4,00	PHP 44H100RSB
45	181,91	180,54	192	5F	20	54	80	33,3	50	4,25	PHP 45H100RSB
48	194,03	192,66	200	5F	20	54	90	33,3	50	4,50	PHP 48H100RSB
50	202,13	200,76	-	5	20	54	90	33,3	50	4,94	PHP 50H100RSB
52	210,21	208,84	-	5	20	54	90	33,3	50	5,38	PHP 52H100RSB
57	230,42	229,05	-	5	20	54	90	33,3	50	5,82	PHP 57H100RSB
58	234,47	233,10	-	5	20	54	90	33,3	50	5,82	PHP 58H100RSB
60	242,55	241,18	-	5	20	70	120	33,3	50	6,25	PHP 60H100RSB
70	282,98	281,61	-	5	20	70	120	33,3	55	7,55	PHP 70H100RSB
72	291,06	289,69	-	5	20	70	120	33,3	55	8,85	PHP 72H100RSB
76	307,23	305,86	-	5	20	70	120	33,3	55	9,43	PHP 76H100RSB
84	339,57	338,20	-	5	20	70	120	33,3	55	10,00	PHP 84H100RSB
96	388,08	386,71	-	5	24	70	120	33,3	60	10,48	PHP 96H100RSB
120	485,10	483,73	-	5	24	70	120	33,3	60	13,10	PHP 120H100RSB
156	630,63	629,26	-	5	24	70	130	33,3	60	17,20	PHP 156H100RSB



Classical timing pulleys

Pilot bore (RSB)



H

1/2" Pitch (12,7 mm)

Type 1F

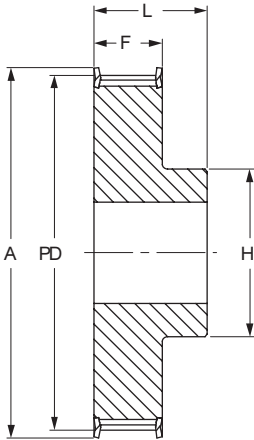

Type 5

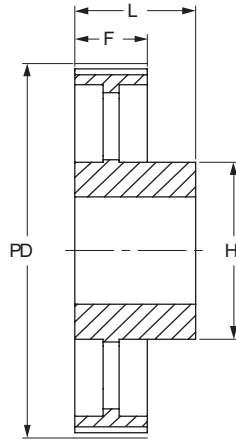

Type 5F

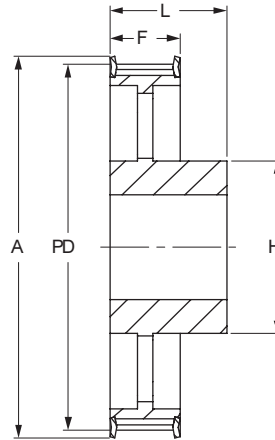

H 150

For Belt Width 38,1 mm

No. Teeth	Diameter			Type	Bore		Dimensions			Weight kg	Designation
	P.D.	O.D.	A		Min	Max	H	F	L		
	mm	mm	mm		mm	mm	mm	mm	mm		
14	56,60	55,23	63	1F	12	27	40	46	58	0,82	PHP 14H150RSB
15	60,64	59,27	67	1F	12	30	46	46	58	0,96	PHP 15H150RSB
16	64,67	63,30	71	1F	12	30	46	46	58	1,10	PHP 16H150RSB
17	68,72	67,35	75	1F	12	30	46	46	58	1,30	PHP 17H150RSB
18	72,77	71,40	79	1F	12	30	55	46	58	1,50	PHP 18H150RSB
19	76,81	75,44	83	1F	12	36	60	46	58	1,70	PHP 19H150RSB
20	80,85	79,48	87	1F	12	41	62	46	58	1,80	PHP 20H150RSB
21	84,89	83,52	91	1F	12	43	67	46	58	2,20	PHP 21H150RSB
22	88,94	87,57	95	1F	12	45	70	46	58	2,30	PHP 22H150RSB
23	92,98	91,61	98	1F	12	46	72	46	58	2,45	PHP 23H150RSB
24	97,03	95,66	103	1F	12	47	75	46	58	2,60	PHP 24H150RSB
25	101,06	99,69	107	1F	12	47	75	46	58	2,90	PHP 25H150RSB
26	105,11	103,74	111	1F	15	54	80	46	58	3,20	PHP 26H150RSB
27	109,15	107,78	115	1F	15	54	80	46	58	3,30	PHP 27H150RSB
28	113,18	111,81	119	1F	15	54	80	46	58	3,39	PHP 28H150RSB
29	117,23	115,86	123	1F	15	54	80	46	58	3,75	PHP 29H150RSB
30	121,29	119,92	127	1F	15	54	80	46	58	4,10	PHP 30H150RSB
31	125,32	123,95	131	1F	15	54	80	46	58	4,43	PHP 31H150RSB
32	129,36	127,99	135	1F	20	54	80	46	58	4,77	PHP 32H150RSB
33	133,40	132,03	142	1F	20	54	80	46	58	5,08	PHP 33H150RSB
34	137,45	136,08	142	1F	20	54	80	46	58	5,40	PHP 34H150RSB
35	141,49	140,12	151	1F	20	54	80	46	58	5,71	PHP 35H150RSB
36	145,53	144,16	151	1F	20	54	80	46	58	6,02	PHP 36H150RSB
38	153,62	152,25	158	1F	20	54	80	46	58	6,76	PHP 38H150RSB
40	161,70	160,33	168	1F	20	54	80	46	58	7,50	PHP 40H150RSB
42	169,79	168,42	184	1F	20	54	80	46	58	8,00	PHP 42H150RSB
44	177,87	176,50	184	5F	20	48	80	46	58	5,00	PHP 44H150RSB
45	181,91	180,54	192	5F	20	48	80	46	58	5,05	PHP 45H150RSB
48	194,03	192,66	200	5F	20	54	90	46	65	5,10	PHP 48H150RSB
50	202,13	200,76	-	5	20	54	90	46	65	5,75	PHP 50H150RSB
52	210,21	208,84	-	5	20	54	90	46	65	6,40	PHP 52H150RSB
57	230,43	229,06	-	5	20	54	90	46	65	6,75	PHP 57H150RSB
58	234,47	233,10	-	5	20	54	90	46	65	7,05	PHP 58H150RSB
60	242,55	241,18	-	5	20	70	120	46	65	7,70	PHP 60H150RSB
70	282,98	281,61	-	5	20	70	120	46	65	8,20	PHP 70H150RSB
72	291,06	289,69	-	5	20	70	120	46	65	8,70	PHP 72H150RSB
76	307,23	305,86	-	5	20	70	120	46	65	9,67	PHP 76H150RSB
84	339,57	338,20	-	5	20	70	120	46	65	10,64	PHP 84H150RSB
96	388,08	386,71	-	5	24	70	120	46	65	13,40	PHP 96H150RSB
120	485,10	483,73	-	5	24	70	120	46	65	15,70	PHP 120H150RSB
156	630,63	629,26	-	5	24	70	130	46	65	19,10	PHP 156H150RSB



Classical timing pulleys

Pilot bore (RSB)

- ▶ Belts
- ▶ Chains
- ▶ Couplings
- ▶ Bushings and Hubs
- ▶ Sprockets
- ▶ Pulleys
- ▶ Smart tools

H

1/2" Pitch (12,7 mm)

Type 1F

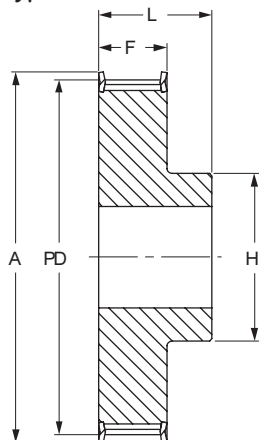

Type 5

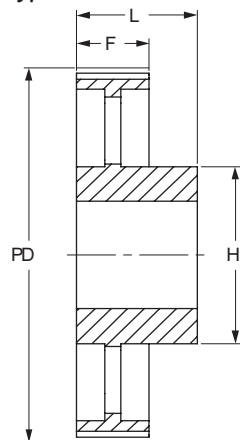

Type 5F

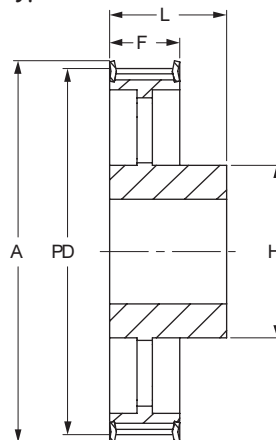

H 200

For Belt Width 50,8 mm

No. Teeth	Diameter			Type	Bore		Dimensions			Weight kg	Designation
	P.D.	O.D.	A		Min	Max	H	F	L		
	mm	mm	mm		mm	mm	mm	mm	mm		
14	56,60	55,23	63	1F	12	27	40	59,5	70	1,25	PHP 14H200RSB
15	60,64	59,27	67	1F	12	30	46	59,5	70	1,33	PHP 15H200RSB
16	64,67	63,30	71	1F	12	30	46	59,5	70	1,40	PHP 16H200RSB
17	68,72	67,35	75	1F	12	30	46	59,5	70	1,67	PHP 17H200RSB
18	72,77	71,40	79	1F	12	30	55	59,5	70	1,94	PHP 18H200RSB
19	76,81	75,44	83	1F	12	36	60	59,5	70	2,18	PHP 19H200RSB
20	80,85	79,48	87	1F	12	41	62	59,5	70	2,43	PHP 20H200RSB
21	84,89	83,52	91	1F	12	43	67	59,5	70	2,60	PHP 21H200RSB
22	88,94	87,57	95	1F	12	45	70	59,5	70	2,80	PHP 22H200RSB
23	92,98	91,61	98	1F	12	46	72	59,5	70	2,89	PHP 23H200RSB
24	97,03	95,66	103	1F	12	47	75	59,5	70	2,97	PHP 24H200RSB
25	101,06	99,69	107	1F	12	47	75	59,5	70	2,89	PHP 25H200RSB
26	105,11	103,74	111	1F	15	54	80	59,5	70	3,90	PHP 26H200RSB
27	109,15	107,78	115	1F	15	54	80	59,5	70	3,44	PHP 27H200RSB
28	113,18	111,81	119	1F	15	54	80	59,5	70	4,60	PHP 28H200RSB
29	117,23	115,86	123	1F	15	54	80	59,5	70	4,80	PHP 29H200RSB
30	121,29	119,92	127	1F	15	54	80	59,5	70	5,00	PHP 30H200RSB
31	125,32	123,95	131	1F	15	54	80	59,5	70	5,47	PHP 31H200RSB
32	129,36	127,99	135	1F	20	54	80	59,5	70	5,93	PHP 32H200RSB
33	133,40	132,03	142	1F	20	54	80	59,5	70	6,33	PHP 33H200RSB
34	137,45	136,08	142	1F	20	54	80	59,5	70	6,73	PHP 34H200RSB
35	141,49	140,12	151	1F	20	54	80	59,5	70	7,13	PHP 35H200RSB
36	145,53	144,16	151	1F	20	54	80	59,5	70	7,53	PHP 36H200RSB
38	153,62	152,25	158	1F	20	54	80	59,5	70	8,32	PHP 38H200RSB
40	161,70	160,33	168	1F	20	54	80	59,5	70	9,11	PHP 40H200RSB
42	169,79	168,42	184	1F	20	54	80	59,5	70	9,70	PHP 42H200RSB
44	177,87	176,50	184	5F	20	48	80	59,5	70	5,00	PHP 44H200RSB
45	181,91	180,54	192	5F	20	48	80	59,5	70	5,37	PHP 45H200RSB
48	194,03	192,66	200	5F	20	54	90	59,5	75	5,73	PHP 48H200RSB
50	202,13	200,76	-	5	20	54	90	59,5	75	6,62	PHP 50H200RSB
52	210,21	208,84	-	5	20	54	90	59,5	75	7,50	PHP 52H200RSB
57	230,43	229,06	-	5	20	54	90	59,5	75	8,76	PHP 57H200RSB
58	234,47	233,10	-	5	20	54	90	59,5	75	8,39	PHP 58H200RSB
60	242,55	241,18	-	5	20	70	120	59,5	75	9,27	PHP 60H200RSB
70	282,98	281,61	-	5	20	70	120	59,5	75	9,80	PHP 70H200RSB
72	291,06	289,69	-	5	20	70	120	59,5	75	10,32	PHP 72H200RSB
76	307,23	305,86	-	5	20	70	120	59,5	75	11,41	PHP 76H200RSB
84	339,57	338,20	-	5	20	70	120	59,5	75	12,50	PHP 84H200RSB
96	388,08	386,71	-	5	24	70	120	59,5	75	14,00	PHP 96H200RSB
120	485,10	483,73	-	5	24	70	120	59,5	75	18,10	PHP 120H200RSB
156	630,63	629,26	-	5	24	70	130	59,5	75	22,00	PHP 156H200RSB



Classical timing pulleys

Pilot bore (RSB)



H

1/2" Pitch (12,7 mm)

Type 1F

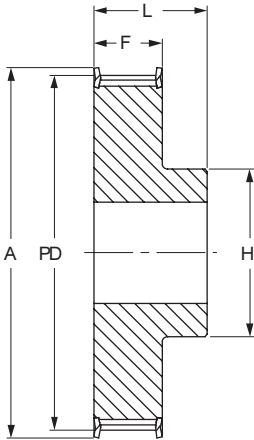

Type 5

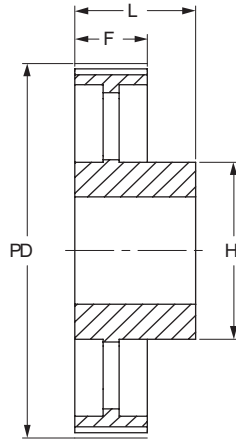

Type 5F

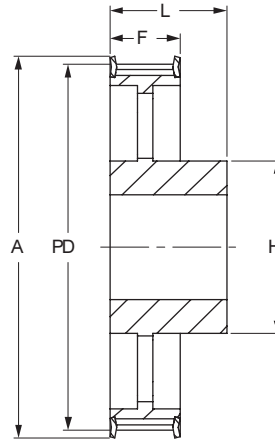

H 300

For Belt Width 76,2 mm

No. Teeth	Diameter			Type	Bore		Dimensions			Weight kg	Designation
	P.D.	O.D.	A		Min	Max	H	F	L		
	mm	mm	mm		mm	mm	mm	mm	mm		
14	56,60	55,23	63	1F	14	27	40	85,5	100	1,80	PHP 14H300RSB
15	60,64	59,27	67	1F	14	30	46	85,5	100	1,90	PHP 15H300RSB
16	64,67	63,30	71	1F	14	30	46	85,5	100	2,00	PHP 16H300RSB
17	68,72	67,35	75	1F	14	30	46	85,5	100	2,24	PHP 17H300RSB
18	72,77	71,40	79	1F	14	30	55	85,5	100	2,47	PHP 18H300RSB
19	76,81	75,44	83	1F	14	36	60	85,5	100	2,90	PHP 19H300RSB
20	80,85	79,48	87	1F	15	41	62	85,5	100	3,20	PHP 20H300RSB
21	84,89	83,52	91	1F	15	43	67	85,5	100	3,60	PHP 21H300RSB
22	88,94	87,57	95	1F	15	45	70	85,5	100	4,00	PHP 22H300RSB
23	92,98	91,61	98	1F	15	46	72	85,5	100	4,35	PHP 23H300RSB
24	97,03	95,66	103	1F	15	47	75	85,5	100	4,70	PHP 24H300RSB
25	101,06	99,69	107	1F	15	47	75	85,5	100	5,24	PHP 25H300RSB
26	105,11	103,74	111	1F	15	54	80	85,5	100	5,78	PHP 26H300RSB
27	109,15	107,78	115	1F	15	54	80	85,5	100	6,16	PHP 27H300RSB
28	113,18	111,81	119	1F	15	54	80	85,5	100	6,54	PHP 28H300RSB
29	117,23	115,86	123	1F	15	54	80	85,5	100	6,77	PHP 29H300RSB
30	121,29	119,92	127	1F	15	54	80	85,5	100	7,00	PHP 30H300RSB
31	125,32	123,95	131	1F	15	54	80	85,5	100	7,83	PHP 31H300RSB
32	129,36	127,99	135	1F	20	54	80	85,5	100	8,66	PHP 32H300RSB
33	133,40	132,03	142	1F	20	54	80	85,5	100	9,23	PHP 33H300RSB
34	137,45	136,08	142	1F	20	54	80	85,5	100	9,79	PHP 34H300RSB
35	141,47	140,10	151	1F	20	54	80	85,5	100	10,36	PHP 35H300RSB
36	145,53	144,16	151	1F	20	54	80	85,5	100	10,92	PHP 36H300RSB
38	153,62	152,25	158	1F	20	54	80	85,5	100	12,20	PHP 38H300RSB
40	161,70	160,33	168	1F	20	54	80	85,5	100	13,50	PHP 40H300RSB
42	169,79	168,42	184	1F	20	54	80	85,5	100	14,50	PHP 42H300RSB
44	177,87	176,50	184	5F	20	48	80	85,5	100	8,06	PHP 44H300RSB
48	194,03	192,66	200	5F	20	54	90	85,5	100	9,67	PHP 48H300RSB
50	202,13	200,76	-	5	20	54	90	85,5	100	10,87	PHP 50H300RSB
57	230,43	229,06	-	5	20	54	90	85,5	100	11,92	PHP 57H300RSB
58	234,47	233,10	-	5	20	54	90	85,5	100	12,07	PHP 58H300RSB
60	242,55	241,18	-	5	20	70	120	85,5	100	13,30	PHP 60H300RSB
72	291,06	289,69	-	5	20	70	120	85,5	100	15,70	PHP 72H300RSB
76	307,24	305,87	-	5	20	70	120	85,5	100	16,17	PHP 76H300RSB
84	339,57	338,20	-	5	20	70	120	85,5	100	17,10	PHP 84H300RSB
96	388,09	386,72	-	5	24	70	120	85,5	100	20,40	PHP 96H300RSB
120	485,12	483,75	-	5	24	70	120	85,5	100	27,80	PHP 120H300RSB
156	630,63	629,26	-	5	24	70	130	85,5	100	35,00	PHP 156H300RSB



Classical timing pulleys

Pilot bore (RSB)

- ▶ Belts
- ▶ Chains
- ▶ Couplings
- ▶ Bushings and Hubs
- ▶ Sprockets
- ▶ Pulleys
- ▶ Smart tools

XH

7/8" Pitch (22,225 mm)

Type 1F

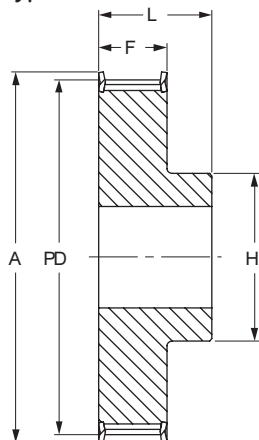

Type 5

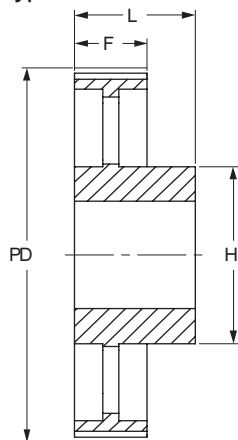

XH 200

For Belt Width 50,8 mm

No. Teeth	Diameter			Type	Bore		Dimensions			Weight	Designation
	P.D.	O.D.	A		Min	Max	H	F	L		
	mm	mm	mm		mm	mm	mm	mm	mm		
18	127,34	124,54	141	1F	24	67	100	65,1	80	5,00	PHP 18XH200RSB
19	134,41	131,61	146	1F	24	67	100	65,1	80	5,50	PHP 19XH200RSB
20	141,49	138,69	155	1F	24	67	100	65,1	80	6,00	PHP 20XH200RSB
21	148,56	145,76	169	1F	24	73	110	65,1	80	6,60	PHP 21XH200RSB
22	155,64	152,84	169	1F	24	73	110	65,1	80	7,20	PHP 22XH200RSB
24	169,79	166,99	183	1F	24	80	120	65,1	80	8,60	PHP 24XH200RSB
25	176,86	174,06	198	1F	24	80	120	65,1	80	9,40	PHP 25XH200RSB
26	183,93	181,13	198	1F	24	80	120	65,1	80	9,70	PHP 26XH200RSB
27	191,01	188,21	212	1F	24	80	120	65,1	80	9,90	PHP 27XH200RSB
28	198,09	195,29	212	1F	24	80	120	65,1	80	10,00	PHP 28XH200RSB
30	212,23	209,43	226	1F	24	80	120	65,1	80	10,40	PHP 30XH200RSB
32	226,38	223,58	240	1F	24	80	120	65,1	80	11,20	PHP 32XH200RSB
34	240,53	237,73	256	1F	24	80	120	65,1	80	12,60	PHP 34XH200RSB
38	268,83	266,03	-	5	28	100	150	65,1	80	14,60	PHP 38XH200RSB
40	282,98	280,18	-	5	28	100	150	65,1	100	16,00	PHP 40XH200RSB
48	339,57	336,77	-	5	28	100	150	65,1	100	18,40	PHP 48XH200RSB
60	424,47	421,67	-	5	28	100	150	65,1	100	24,30	PHP 60XH200RSB



Classical timing pulleys

Pilot bore (RSB)



XH

7/8" Pitch (22,225 mm)

Type 1F

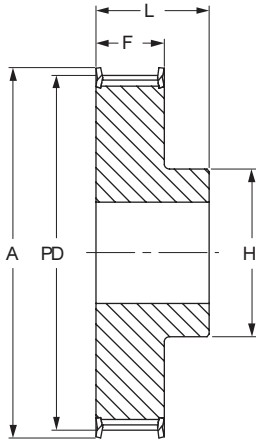

Type 5

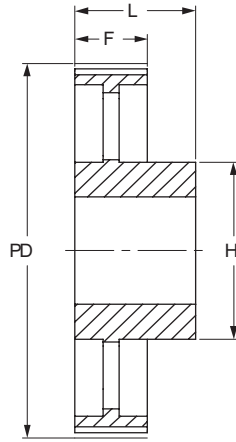

XH 300

For Belt Width 76,2 mm

No. Teeth	Diameter			Type	Bore		Dimensions			Weight	Designation
	P.D.	O.D.	A		Min	Max	H	F	L		
	mm	mm	mm		mm	mm	mm	mm	mm		
18	127,34	124,54	141	1F	28	67	100	92,1	110	6,80	PHP 18XH300RSB
19	134,41	131,61	146	1F	28	67	100	92,1	110	7,10	PHP 19XH300RSB
20	141,49	138,69	155	1F	28	67	100	92,1	110	7,40	PHP 20XH300RSB
21	148,56	145,76	169	1F	28	73	110	92,1	110	8,20	PHP 21XH300RSB
22	155,64	152,84	169	1F	28	73	110	92,1	110	9,00	PHP 22XH300RSB
24	169,79	166,99	183	1F	28	80	120	92,1	110	10,60	PHP 24XH300RSB
25	176,86	174,06	198	1F	28	80	120	92,1	110	11,80	PHP 25XH300RSB
26	183,93	181,13	198	1F	28	80	120	92,1	110	12,00	PHP 26XH300RSB
27	191,01	188,21	212	1F	28	80	120	92,1	110	12,50	PHP 27XH300RSB
28	198,09	195,29	212	1F	28	80	150	92,1	110	13,00	PHP 28XH300RSB
30	212,23	209,43	226	1F	28	80	150	92,1	110	13,75	PHP 30XH300RSB
32	226,38	223,58	240	1F	28	80	150	92,1	110	14,70	PHP 32XH300RSB
34	240,53	237,73	256	1F	28	80	150	92,1	110	16,30	PHP 34XH300RSB
38	268,83	266,03	-	5	32	100	150	92,1	120	18,30	PHP 38XH300RSB
40	282,98	280,18	-	5	32	100	150	92,1	120	19,90	PHP 40XH300RSB
48	339,57	336,77	-	5	32	100	175	92,1	120	22,50	PHP 48XH300RSB
60	424,47	421,67	-	5	32	100	175	92,1	120	31,50	PHP 60XH300RSB



Classical timing pulleys

Pilot bore (RSB)

- ▶ Belts
- ▶ Chains
- ▶ Couplings
- ▶ Bushings and Hubs
- ▶ Sprockets
- ▶ Pulleys
- ▶ Smart tools

XH

7/8" Pitch (22,225 mm)

Type 1F

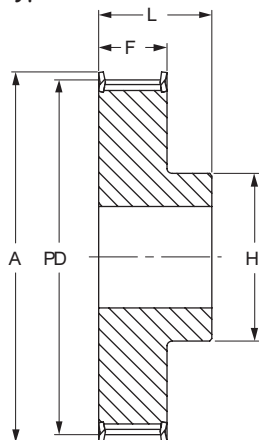

Type 5

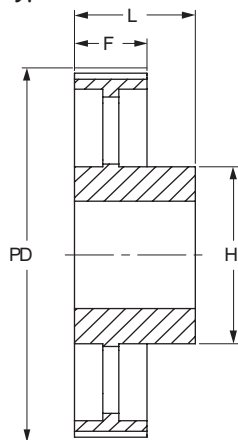

XH 400

For Belt Width 101,6 mm

No. Teeth	Diameter			Type	Bore		Dimensions			Weight	Designation
	P.D.	O.D.	A		Min	Max	H	F	L		
	mm	mm	mm		mm	mm	mm	mm	mm		
18	127,34	124,54	141	1F	32	67	100	119	132	8,50	PHP 18XH400RSB
19	134,41	131,61	146	1F	32	67	100	119	132	9,00	PHP 19XH400RSB
20	141,49	138,69	155	1F	32	67	100	119	132	9,40	PHP 20XH400RSB
21	148,56	145,76	169	1F	32	73	110	119	132	10,50	PHP 21XH400RSB
22	155,64	152,84	169	1F	32	73	110	119	132	11,50	PHP 22XH400RSB
24	169,79	166,99	183	1F	32	80	120	119	132	13,40	PHP 24XH400RSB
25	176,86	174,06	198	1F	32	80	120	119	132	14,50	PHP 25XH400RSB
26	183,93	181,13	198	1F	32	80	120	119	132	15,60	PHP 26XH400RSB
27	191,01	188,21	212	1F	32	80	120	119	132	15,10	PHP 27XH400RSB
28	198,09	195,29	212	1F	32	100	150	119	132	14,50	PHP 28XH400RSB
30	212,23	209,43	227	1F	32	100	150	119	132	16,00	PHP 30XH400RSB
32	226,38	223,58	240	1F	32	100	150	119	132	18,00	PHP 32XH400RSB
34	240,53	237,73	256	1F	32	100	150	119	132	20,00	PHP 34XH400RSB
38	268,83	266,03	-	5	32	100	150	119	132	22,00	PHP 38XH400RSB
40	282,98	280,18	-	5	32	100	150	119	132	24,00	PHP 40XH400RSB
48	339,57	336,77	-	5	32	110	175	119	132	30,80	PHP 48XH400RSB
60	424,47	421,67	-	5	32	110	175	119	132	36,20	PHP 60XH400RSB



Classical timing pulleys

Taper bushed



L 3/8" Pitch (9,525 mm)

Type 3F

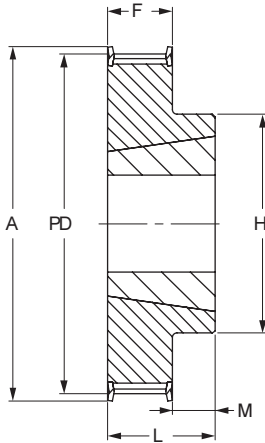

Type 9

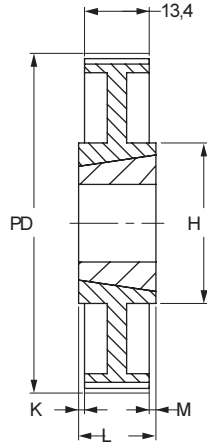

Type 9F

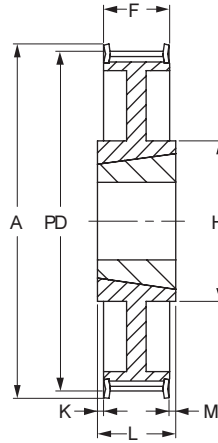

L 050

For Belt Width 12,7 mm

No. Teeth	Diameter			Type	Bush	Bore		Dimensions					Weight kg	Designation
	P.D.	O.D.	A			Min mm	Max mm	H mm	F mm	K mm	L mm	M mm		
	mm	mm	mm											
18	54,57	53,81	60	3F	1108	9	28	45	19,1	-	22	3,0	0,18	PHP 18L050TB
19	57,61	56,85	63	3F	1108	9	28	45	19,1	-	22	3,0	0,21	PHP 19L050TB
20	60,64	59,88	66	3F	1108	9	28	47	19,1	-	22	3,0	0,24	PHP 20L050TB
21	63,67	62,91	69	3F	1108	9	28	49	19,1	-	22	3,0	0,30	PHP 21L050TB
22	66,70	65,94	72	3F	1108	9	28	53	19,1	-	22	3,0	0,36	PHP 22L050TB
23	69,73	68,97	78	3F	1108	9	28	54	19,1	-	22	3,0	0,39	PHP 23L050TB
24	72,77	72,01	78	3F	1108	9	28	54	19,1	-	22	3,0	0,42	PHP 24L050TB
25	75,80	75,04	85	3F	1108	9	28	56	19,1	-	22	3,0	0,49	PHP 25L050TB
26	78,83	78,07	85	3F	1108	9	28	60	19,1	-	22	3,0	0,54	PHP 26L050TB
27	81,86	81,10	91	3F	1108	9	28	62	19,1	-	22	3,0	0,61	PHP 27L050TB
28	84,89	84,13	91	3F	1108	9	28	63	19,1	-	22	3,0	0,64	PHP 28L050TB
30	90,06	89,30	97	3F	1108	9	28	70	19,1	-	22	3,0	0,77	PHP 30L050TB
32	97,02	96,26	103	3F	1108	9	28	74	19,1	-	22	3,0	0,89	PHP 32L050TB
36	109,15	108,39	115	3F	1108	9	28	85	19,1	-	22	3,0	1,18	PHP 36L050TB
40	121,28	120,52	127	3F	1610	14	42	90	19,1	-	25	6,0	1,35	PHP 40L050TB
44	133,40	132,64	139	3F	1610	14	42	90	19,1	-	25	6,0	1,60	PHP 44L050TB
48	145,53	144,77	152	9F	1610	14	42	92	19,1	-	25	6,0	1,80	PHP 48L050TB
60	181,91	181,15	-	9	1610	14	42	92	19,1	3,0	25	3,0	2,46	PHP 60L050TB
72	218,30	217,54	-	9	1610	14	42	92	19,1	3,0	25	3,0	3,29	PHP 72L050TB
84	254,68	253,92	-	9	1610	14	42	92	19,1	3,0	25	3,0	4,12	PHP 84L050TB
96	291,06	290,30	-	9	2012	14	50	111	19,1	6,5	32	6,5	4,55	PHP 96L050TB
120	363,83	363,07	-	9	2012	14	50	111	19,1	6,5	32	6,5	5,71	PHP 120L050TB



Classical timing pulleys

Taper bushed

- ▶ Belts
- ▶ Chains
- ▶ Couplings
- ▶ Bushings and Hubs
- ▶ Sprockets
- ▶ Pulleys
- ▶ Smart tools

L

3/8" Pitch (9,525 mm)

Type 2F

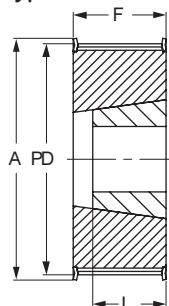

Type 7

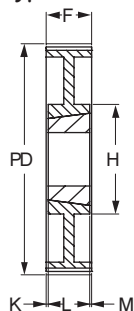

Type 7F

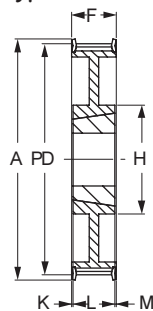

Type 8

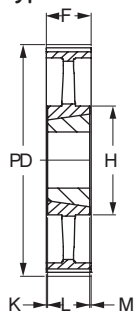

Type 9

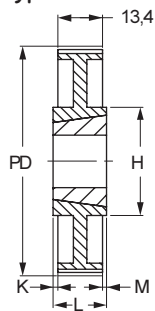

L 075

For Belt Width 19,1 mm

No. Teeth	Diameter			Type	Bush	Bore		Dimensions					Weight	Designation
	P.D.	O.D.	A			Min	Max	H	F	K	L	M		
	mm	mm	mm			mm	mm	mm	mm	mm	mm	mm		
18	54,57	53,81	60	2F	1108	9	28	-	25,4	-	25	-	0,20	PHP 18L075TB
19	57,61	56,85	63	2F	1108	9	28	-	25,4	-	25	-	0,30	PHP 19L075TB
20	60,64	59,88	66	2F	1108	9	28	-	25,4	-	25	-	0,30	PHP 20L075TB
21	63,67	62,91	69	2F	1108	9	28	-	25,4	-	25	-	0,40	PHP 21L075TB
22	66,70	65,94	72	2F	1108	9	28	-	25,4	-	25	-	0,40	PHP 22L075TB
23	69,73	68,97	78	2F	1108	9	28	-	25,4	-	25	-	0,50	PHP 23L075TB
24	72,77	72,01	78	2F	1108	9	28	-	25,4	-	25	-	0,50	PHP 24L075TB
25	75,80	75,04	85	2F	1108	9	28	-	25,4	-	25	-	0,60	PHP 25L075TB
26	78,83	78,07	85	2F	1108	9	28	-	25,4	-	25	-	0,70	PHP 26L075TB
27	81,86	81,10	91	2F	1108	9	28	-	25,4	-	25	-	0,70	PHP 27L075TB
28	84,89	84,13	91	2F	1108	9	28	-	25,4	-	25	-	0,80	PHP 28L075TB
30	90,96	90,20	97	2F	1108	9	28	-	25,4	-	25	-	1,00	PHP 30L075TB
32	97,02	96,26	103	2F	1108	9	28	-	25,4	-	25	-	1,10	PHP 32L075TB
36	109,15	108,39	115	2F	1610	14	42	-	25,4	-	25	-	1,20	PHP 36L075TB
40	121,28	120,52	127	2F	1610	14	42	-	25,4	-	25	-	1,60	PHP 40L075TB
44	133,40	132,64	139	2F	1610	14	42	-	25,4	-	25	-	1,90	PHP 44L075TB
48	145,53	144,77	152	7F	1610	14	42	92	25,4	-	25	-	2,20	PHP 48L075TB
60	181,91	181,15	-	7	1610	14	42	92	25,4	-	25	-	3,00	PHP 60L075TB
72	218,30	217,54	-	8	1610	14	42	92	25,4	-	25	-	4,00	PHP 72L075TB
84	254,68	253,92	-	9	2012	14	50	106	25,4	3,5	32	3,5	5,20	PHP 84L075TB
96	291,06	290,30	-	9	2012	14	50	106	25,4	3,5	32	3,5	6,50	PHP 96L075TB
120	363,83	363,07	-	9	2012	14	50	106	25,4	3,5	32	3,5	7,60	PHP 120L075TB



Classical timing pulleys

Taper bushed



L 3/8" Pitch (9,525 mm)

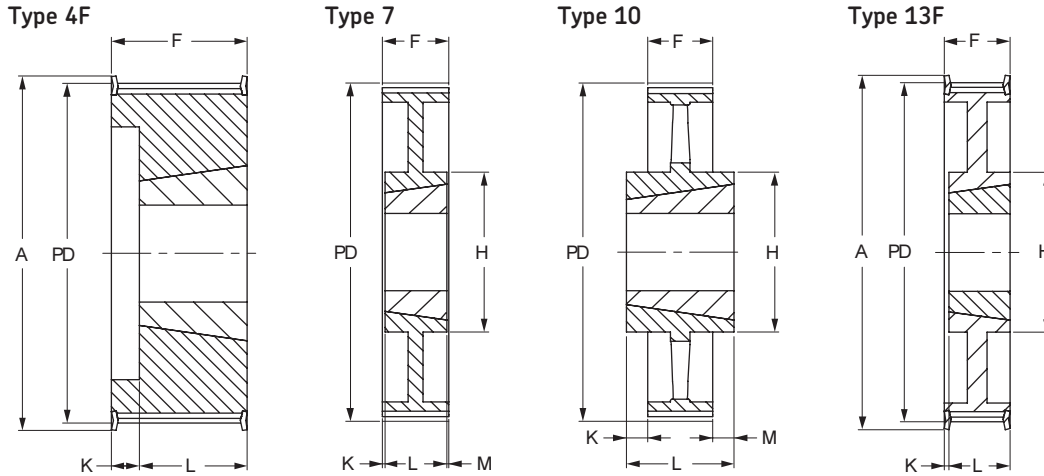

L 100
For Belt Width 25,4 mm

No. Teeth	Diameter			Type	Bush	Bore		Dimensions					Weight kg	Designation
	P.D.	O.D.	A			Min	Max	H	F	K	L	M		
	mm	mm	mm			mm	mm	mm	mm	mm	mm	mm		
18	54,57	53,81	60	4F	1108	9	28	-	31,8	10,0	22	-	0,27	PHP 18L100TB
19	57,61	56,85	63	4F	1108	9	28	-	31,8	10,0	22	-	0,30	PHP 19L100TB
20	60,64	59,88	66	4F	1108	9	28	-	31,8	10,0	22	-	0,36	PHP 20L100TB
21	63,67	62,91	69	4F	1108	9	28	-	31,8	10,0	22	-	0,44	PHP 21L100TB
22	66,70	65,94	72	4F	1108	9	28	-	31,8	10,0	22	-	0,51	PHP 22L100TB
23	69,73	68,97	78	4F	1108	9	28	-	31,8	10,0	22	-	0,54	PHP 23L100TB
24	72,77	72,01	78	4F	1108	9	28	-	31,8	10,0	22	-	0,58	PHP 24L100TB
25	75,80	75,04	85	4F	1108	9	28	-	31,8	10,0	22	-	0,67	PHP 25L100TB
26	78,83	78,07	85	4F	1108	9	28	-	31,8	10,0	22	-	0,72	PHP 26L100TB
27	81,86	81,10	91	4F	1108	9	28	-	31,8	10,0	22	-	0,80	PHP 27L100TB
28	84,89	84,13	91	4F	1108	9	28	-	31,8	10,0	22	-	0,83	PHP 28L100TB
30	90,96	90,20	97	4F	1210	11	32	-	31,8	7,0	25	-	0,94	PHP 30L100TB
32	97,02	96,26	103	4F	1210	11	32	-	31,8	7,0	25	-	1,10	PHP 32L100TB
36	109,15	108,39	115	4F	1610	14	42	-	31,8	7,0	25	-	1,33	PHP 36L100TB
40	121,28	120,52	127	4F	1610	14	42	-	31,8	7,0	25	-	1,70	PHP 40L100TB
44	133,40	132,64	139	4F	1610	14	42	-	31,8	7,0	25	-	2,30	PHP 44L100TB
48	145,53	144,77	152	13F	1610	14	42	92	31,8	7,0	25	-	2,60	PHP 48L100TB
60	181,91	181,15	-	7	1610	14	42	92	31,8	3,5	25	3,5	3,76	PHP 60L100TB
72	218,30	217,54	-	10	2012	14	50	111	31,8	-	32	-	4,40	PHP 72L100TB
84	254,68	253,92	-	10	2012	14	50	111	31,8	-	32	-	5,87	PHP 84L100TB
96	291,06	290,30	-	10	2012	14	50	111	31,8	-	32	-	7,26	PHP 96L100TB
120	363,83	363,07	-	10	2012	14	50	111	31,8	-	32	-	8,50	PHP 120L100TB



Classical timing pulleys

Taper bushed

- ▶ Belts
- ▶ Chains
- ▶ Couplings
- ▶ Bushings and Hubs
- ▶ Sprockets
- ▶ Pulleys
- ▶ Smart tools

H

1/2" Pitch (12,7 mm)

Type 2F

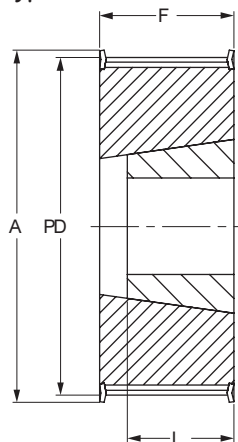

Type 9

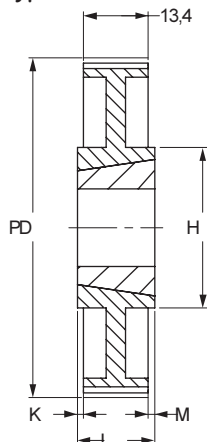

Type 9F

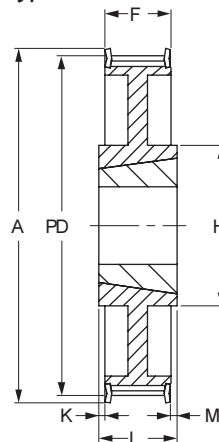

Type 14F

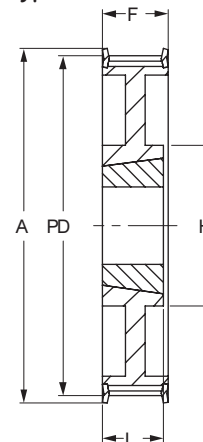

H 075

For Belt Width 19,1 mm

No. Teeth	Diameter			Type	Bush	Bore		Dimensions					Weight kg	Designation
	P.D.	O.D.	A			Min	Max	H	F	K	L	M		
14	56,60	55,23	62	2F	1108	9	28	-	27	-	22	-	0,48	PHP 14H075TB
15	60,64	59,27	67	2F	1108	9	28	-	27	-	22	-	0,53	PHP 15H075TB
16	64,67	63,30	71	2F	1108	9	28	-	27	-	22	-	0,57	PHP 16H075TB
17	68,72	67,35	75	2F	1108	9	28	-	27	-	22	-	0,67	PHP 17H075TB
18	72,77	71,40	79	2F	1210	11	32	-	27	-	25	-	0,76	PHP 18H075TB
19	76,81	75,44	83	2F	1210	11	32	-	27	-	25	-	0,95	PHP 19H075TB
20	80,85	79,48	87	2F	1210	11	32	-	27	-	25	-	1,05	PHP 20H075TB
21	84,89	83,52	91	2F	1210	11	32	-	27	-	25	-	1,14	PHP 21H075TB
22	88,94	87,57	95	2F	1210	11	32	-	27	-	25	-	1,33	PHP 22H075TB
23	92,98	91,61	98	2F	1610	14	42	-	27	-	25	-	1,43	PHP 23H075TB
24	97,02	95,65	103	2F	1610	14	42	-	27	-	25	-	1,52	PHP 24H075TB
25	101,06	99,69	107	2F	1610	14	42	-	27	-	25	-	1,62	PHP 25H075TB
26	105,11	103,74	111	2F	1610	14	42	-	27	-	25	-	1,71	PHP 26H075TB
27	109,15	107,78	115	2F	1610	14	42	-	27	-	25	-	1,81	PHP 27H075TB
28	113,19	111,82	119	2F	1610	14	42	-	27	-	25	-	1,90	PHP 28H075TB
29	117,23	115,86	123	2F	1610	14	42	-	27	-	25	-	1,95	PHP 29H075TB
30	121,28	119,91	127	2F	1610	14	42	-	27	-	25	-	2,00	PHP 30H075TB
32	129,36	127,99	135	14F	1610	14	42	92	27	-	25	-	2,09	PHP 32H075TB
33	133,40	132,03	142	14F	1610	14	42	92	27	-	25	-	2,14	PHP 33H075TB
34	137,45	136,08	142	14F	1610	14	42	92	27	-	25	-	2,19	PHP 34H075TB
35	141,49	140,12	151	14F	1610	14	42	92	27	-	25	-	2,24	PHP 35H075TB
36	145,53	144,16	151	14F	1610	14	42	92	27	-	25	-	2,28	PHP 36H075TB
38	153,62	152,25	158	14F	1610	14	42	92	27	-	25	-	2,47	PHP 38H075TB
40	161,70	160,33	168	14F	1610	14	42	92	27	-	25	-	2,66	PHP 40H075TB
44	177,87	176,50	184	9F	2012	14	50	106	27	2,5	32	2,5	2,57	PHP 44H075TB
48	194,04	192,67	200	9F	2012	14	50	106	27	2,5	32	2,5	2,85	PHP 48H075TB
60	242,55	241,18	-	9	2012	14	50	106	27	2,5	32	2,5	2,90	PHP 60H075TB
72	291,06	289,69	-	9	2012	14	50	112	27	2,5	32	2,5	3,00	PHP 72H075TB
84	339,57	338,20	-	9	2012	14	50	112	27	2,5	32	2,5	3,15	PHP 84H075TB
96	388,08	386,71	-	9	2517	16	60	125	27	9,0	45	9,0	3,50	PHP 96H075TB
120	485,10	483,73	-	9	2517	16	60	125	27	9,0	45	9,0	4,25	PHP 120H075TB



Classical timing pulleys

Taper bushed



H

1/2" Pitch (12,7 mm)

Type 4F

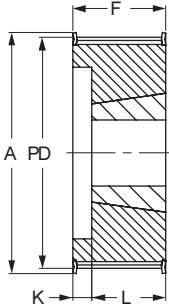

Type 8

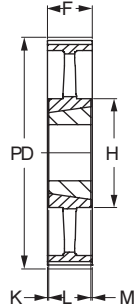

Type 9

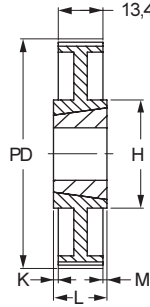

Type 13F

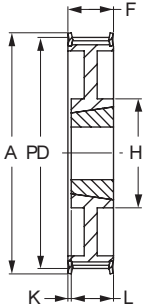

Type 14F

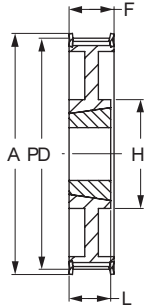

H 100

For Belt Width 25,4 mm

No. Teeth	Diameter			Type	Bush	Bore		Dimensions					Weight	Designation
	P.D.	O.D.	A			Min	Max	H	F	K	L	M		
	mm	mm	mm			mm	mm	mm	mm	mm	mm	mm		
14	56,6	55,23	63	4F	1108	9	28	-	31	9,0	22	-	0,30	PHP 14H100TB
15	60,6	59,23	67	4F	1108	9	28	-	31	9,0	22	-	0,40	PHP 15H100TB
16	64,7	63,33	71	4F	1108	9	28	-	31	9,0	22	-	0,40	PHP 16H100TB
17	68,7	67,33	75	4F	1108	9	28	-	31	9,0	22	-	0,50	PHP 17H100TB
18	72,8	71,43	79	4F	1210	11	32	-	31	6,0	25	-	0,50	PHP 18H100TB
19	76,8	75,43	83	4F	1210	11	32	-	31	6,0	25	-	0,60	PHP 19H100TB
20	80,8	79,43	87	4F	1210	11	32	-	31	6,0	25	-	0,80	PHP 20H100TB
21	84,9	83,53	91	4F	1210	11	32	-	32	7,0	25	-	0,80	PHP 21H100TB
22	88,9	87,53	95	4F	1210	11	32	-	32	7,0	25	-	0,90	PHP 22H100TB
23	93,0	91,63	98	4F	1610	14	42	-	32	7,0	25	-	0,90	PHP 23H100TB
24	97,0	95,63	103	4F	1610	14	42	-	32	7,0	25	-	1,00	PHP 24H100TB
25	101,1	99,73	107	4F	1610	14	42	-	32	7,0	25	-	1,10	PHP 25H100TB
26	105,1	103,73	111	4F	1610	14	42	-	32	7,0	25	-	1,20	PHP 26H100TB
27	109,2	107,83	115	4F	1610	14	42	-	32	7,0	25	-	1,40	PHP 27H100TB
28	113,2	111,83	119	4F	1610	14	42	-	32	7,0	25	-	1,50	PHP 28H100TB
30	121,3	119,93	127	4F	1610	14	42	-	32	7,0	25	-	1,70	PHP 30H100TB
32	129,4	128,03	135	13F	1610	14	42	92	32	7,0	25	-	1,70	PHP 32H100TB
36	145,5	144,13	151	13F	1610	14	42	92	32	7,0	25	-	2,30	PHP 36H100TB
40	161,7	160,33	168	13F	1610	14	42	92	32	7,0	25	-	2,70	PHP 40H100TB
44	177,9	176,53	184	14F	2012	14	50	106	32	7,0	32	-	3,70	PHP 44H100TB
48	194,0	192,63	200	14F	2012	14	50	106	32	7,0	32	-	4,70	PHP 48H100TB
60	242,6	241,23	-	8	2012	14	50	106	34	1,0	32	1,0	7,50	PHP 60H100TB
72	291,1	289,73	-	8	2012	14	50	106	34	1,0	32	1,0	8,40	PHP 72H100TB
84	339,6	338,23	-	8	2012	14	50	106	34	1,0	32	1,0	9,00	PHP 84H100TB
96	388,1	386,73	-	9	2517	16	60	124	34	5,5	45	5,5	11,00	PHP 96H100TB
120	485,1	483,73	-	9	2517	16	60	124	34	5,5	45	5,5	14,00	PHP 120H100TB



Classical timing pulleys

Taper bushed

- ▶ Belts
- ▶ Chains
- ▶ Couplings
- ▶ Bushings and Hubs
- ▶ Sprockets
- ▶ Pulleys
- ▶ Smart tools

H

1/2" Pitch (12,7 mm)

Type 4F

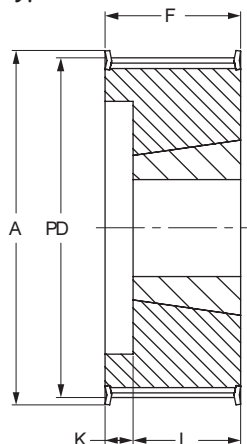

Type 8

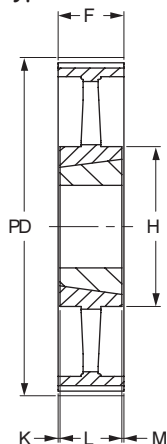

Type 13F

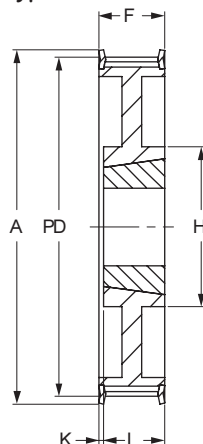

H 150

For Belt Width 38,1 mm

No. Teeth	Diameter			Type	Bush	Bore		Dimensions					Weight kg	Designation
	P.D.	O.D.	A			Min	Max	H	F	K	L	M		
14	56,60	55,23	63	4F	1108	9	28	-	45	23	22	-	0,50	PHP 14H150TB
16	64,67	63,30	71	4F	1108	9	28	-	45	23	22	-	0,60	PHP 16H150TB
18	72,77	71,40	79	4F	1210	11	32	-	45	20	25	-	0,69	PHP 18H150TB
19	76,81	75,44	83	4F	1210	11	32	-	45	20	25	-	0,86	PHP 19H150TB
20	80,85	79,48	87	4F	1210	11	32	-	45	20	25	-	0,98	PHP 20H150TB
21	84,89	83,52	91	4F	1210	11	32	-	45	20	25	-	0,98	PHP 21H150TB
22	88,94	87,57	95	4F	1210	11	32	-	45	20	25	-	1,10	PHP 22H150TB
23	92,98	91,61	98	4F	1610	14	42	-	45	20	25	-	1,16	PHP 23H150TB
24	97,02	95,65	103	4F	1610	14	42	-	45	20	25	-	1,22	PHP 24H150TB
25	101,06	99,69	107	4F	1610	14	42	-	45	20	25	-	1,37	PHP 25H150TB
26	105,11	103,74	111	4F	1610	14	42	-	45	20	25	-	1,51	PHP 26H150TB
27	109,15	107,78	115	4F	1610	14	42	-	45	20	25	-	1,67	PHP 27H150TB
28	113,19	111,82	119	4F	1610	14	42	-	45	20	25	-	1,77	PHP 28H150TB
30	121,28	119,91	127	4F	1610	14	42	-	45	20	25	-	2,05	PHP 30H150TB
32	129,36	127,99	135	13F	1610	14	42	92	45	20	25	-	2,07	PHP 32H150TB
36	145,53	144,16	151	13F	1610	14	42	92	45	20	25	-	2,76	PHP 36H150TB
40	161,70	160,33	168	13F	1610	14	42	92	45	20	25	-	3,34	PHP 40H150TB
44	177,87	176,50	184	13F	2012	14	50	106	45	13	32	-	5,19	PHP 44H150TB
48	194,34	192,97	200	13F	2012	14	50	106	45	13	32	-	5,70	PHP 48H150TB
60	242,55	241,18	-	8	2012	14	50	106	46	7	32	7,0	6,81	PHP 60H150TB
72	291,06	289,69	-	8	2012	14	50	106	46	7	32	7,0	7,79	PHP 72H150TB
84	339,57	338,20	-	8	2012	14	50	111	46	7	32	7,0	9,15	PHP 84H150TB
96	388,08	386,71	-	8	2517	16	60	124	46	0,5	45	0,5	13,00	PHP 96H150TB
120	485,10	483,73	-	8	2517	16	60	124	46	0,5	45	0,5	16,80	PHP 120H150TB



Classical timing pulleys

Taper bushed



H

1/2" Pitch (12,7 mm)

Type 4F

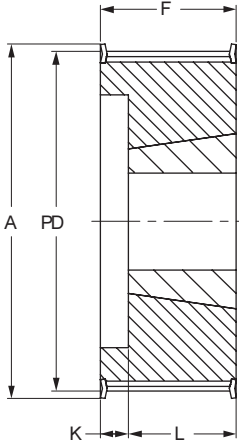

Type 8

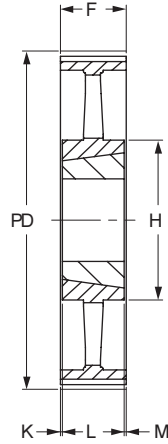

Type 13F

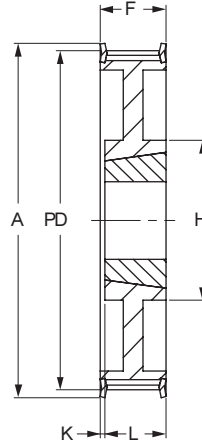

H 200

For Belt Width 50,8 mm

No. Teeth	Diameter			Type	Bush	Bore		Dimensions				Weight kg	Designation
	P.D.	O.D.	A			Min	Max	F	K	L	M		
	mm	mm	mm			mm	mm	mm	mm	mm	mm		
16	64,57	63,20	71	4F	1108	9	28	58	36	22	-	0,80	PHP 16H200TB
18	72,77	71,40	79	4F	1210	11	32	58	33	25	-	0,91	PHP 18H200TB
19	76,81	75,44	83	4F	1210	11	32	58	33	25	-	1,05	PHP 19H200TB
20	80,85	79,48	87	4F	1610	14	42	58	33	25	-	0,92	PHP 20H200TB
21	84,89	83,52	91	4F	1610	14	42	58	33	25	-	1,04	PHP 21H200TB
22	88,94	87,57	95	4F	1610	14	42	58	33	25	-	1,18	PHP 22H200TB
23	92,98	91,61	98	4F	1610	14	42	58	33	25	-	1,28	PHP 23H200TB
24	97,02	95,65	103	4F	1610	14	42	58	33	25	-	1,37	PHP 24H200TB
25	101,06	99,69	107	4F	1610	14	42	58	33	25	-	1,59	PHP 25H200TB
26	105,11	103,74	111	4F	1610	14	42	58	33	25	-	1,63	PHP 26H200TB
27	109,15	107,78	115	4F	1610	14	42	58	33	25	-	1,98	PHP 27H200TB
28	113,19	111,82	119	4F	1610	14	42	58	33	25	-	1,92	PHP 28H200TB
30	121,28	119,91	127	4F	1610	14	42	58	33	25	-	2,24	PHP 30H200TB
32	129,36	127,99	135	4F	2012	14	50	58	26	32	-	2,87	PHP 32H200TB
36	145,53	144,16	151	13F	2012	14	50	58	26	32	-	3,42	PHP 36H200TB
40	161,70	160,33	168	13F	2012	14	50	58	26	32	-	4,39	PHP 40H200TB
44	177,87	176,50	184	13F	2012	14	50	58	26	32	-	5,89	PHP 44H200TB
48	194,04	192,67	200	13F	2517	16	60	58	13	45	-	7,00	PHP 48H200TB
60	242,55	241,18	-	8	2517	16	60	60	7,5	45	7,5	8,88	PHP 60H200TB
72	291,06	289,69	-	8	2517	16	60	60	7,5	45	7,5	9,05	PHP 72H200TB
84	339,57	338,20	-	8	2517	16	60	60	7,5	45	7,5	10,66	PHP 84H200TB
96	388,08	386,71	-	8	2517	16	60	60	7,5	45	7,5	15,28	PHP 96H200TB
120	485,10	483,73	-	8	2517	16	60	60	7,5	45	7,5	20,16	PHP 120H200TB



Classical timing pulleys

Taper bushed

- ▶ Belts
- ▶ Chains
- ▶ Couplings
- ▶ Bushings and Hubs
- ▶ Sprockets
- ▶ Pulleys
- ▶ Smart tools

H

1/2" Pitch (12,7 mm)

Type 6F

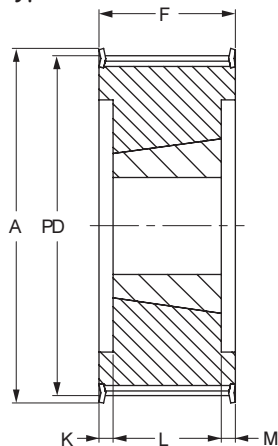

Type 7F

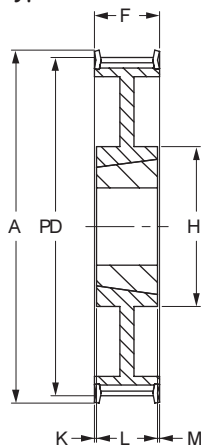

Type 8

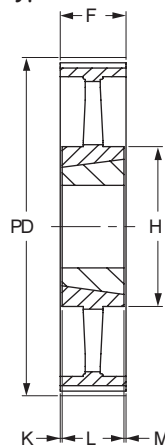

H 300

For Belt Width 76,2 mm

No. Teeth	Diameter			Type	Bush	Bore		Dimensions					Weight kg	Designation
	P.D.	O.D.	A			Min mm	Max mm	H mm	F mm	K mm	L mm	M mm		
	mm	mm	mm											
18	72,77	71,40	83	6F	1215	11	32	-	84	23,0	38	23,0	1,10	PHP 18H300TB
20	80,85	79,48	87	6F	1615	14	42	-	84	23,0	38	23,0	1,25	PHP 20H300TB
21	84,89	83,52	91	6F	1615	14	42	-	84	23,0	38	23,0	1,56	PHP 21H300TB
22	88,94	87,57	94	6F	1615	14	42	-	84	23,0	38	23,0	1,75	PHP 22H300TB
23	92,98	91,61	98	6F	1615	14	42	-	84	23,0	38	23,0	1,93	PHP 23H300TB
24	97,02	95,65	103	6F	1615	14	42	-	84	23,0	38	23,0	2,14	PHP 24H300TB
25	101,06	99,69	107	6F	1615	14	42	-	84	23,0	38	23,0	2,21	PHP 25H300TB
26	105,11	103,74	111	6F	1615	14	42	-	84	23,0	38	23,0	2,65	PHP 26H300TB
27	109,15	107,78	115	6F	2012	14	50	-	84	26,0	32	26,0	2,49	PHP 27H300TB
28	113,19	111,82	119	6F	2012	14	50	-	84	26,0	32	26,0	2,88	PHP 28H300TB
30	121,28	119,91	127	6F	2012	14	50	-	84	26,0	32	26,0	3,44	PHP 30H300TB
32	129,36	127,99	135	6F	2517	16	60	-	84	19,5	45	19,5	3,51	PHP 32H300TB
36	145,53	144,16	151	6F	2517	16	60	-	84	19,5	45	19,5	4,43	PHP 36H300TB
40	161,70	160,33	168	6F	2517	16	60	-	84	19,5	45	19,5	6,10	PHP 40H300TB
44	177,87	176,50	184	7F	2517	16	60	124	86	20,5	45	20,5	7,55	PHP 44H300TB
48	194,04	192,67	200	7F	2517	16	60	124	86	20,5	45	20,5	8,99	PHP 48H300TB
60	242,55	241,18	-	8	2517	16	60	124	86	20,5	45	20,5	11,06	PHP 60H300TB
72	291,06	289,69	-	8	2517	16	60	124	86	20,5	45	20,5	12,66	PHP 72H300TB
84	339,57	338,20	-	8	2517	16	60	124	86	20,5	45	20,5	14,50	PHP 84H300TB
96	388,08	386,71	-	8	3030	35	75	155	86	5,0	76	5,0	16,20	PHP 96H300TB
120	485,10	483,73	-	8	3030	35	75	155	86	5,0	76	5,0	20,80	PHP 120H300TB



Classical timing pulleys

Taper bushed



XH

7/8" Pitch (22,225 mm)

Type 6F

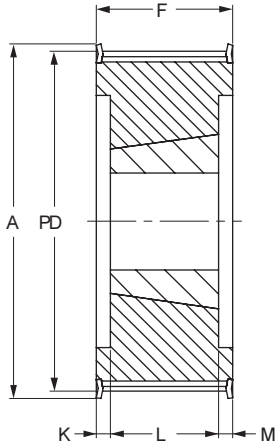

Type 7F

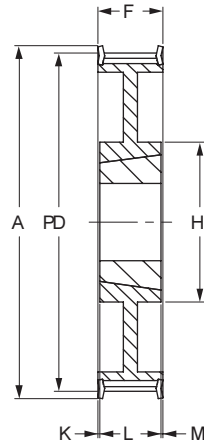

Type 8

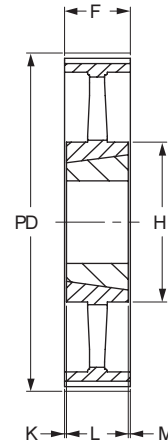

Type 8F

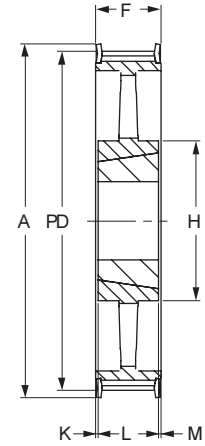

XH 200

For Belt Width 50,8 mm

No. Teeth	Diameter			Type	Bush	Bore		Dimensions			Weight	Designation
	P.D.	O.D.	A			Min	Max	H	F	L		
	mm	mm	mm									
18	127,34	124,54	141	6F	2012	14	50	-	65,1	32	2,60	PHP 18XH200TB
19	134,41	131,61	146	6F	2012	14	50	-	65,1	32	3,10	PHP 19XH200TB
20	141,49	138,69	155	6F	2012	14	50	-	65,1	32	3,60	PHP 20XH200TB
21	148,56	145,76	169	6F	2517	16	60	-	65,1	45	4,20	PHP 21XH200TB
22	155,64	152,84	169	6F	2517	16	60	-	65,1	45	4,80	PHP 22XH200TB
24	169,79	166,99	183	6F	2517	16	60	-	65,1	45	6,10	PHP 24XH200TB
25	176,86	174,06	198	6F	2517	16	60	-	65,1	45	6,80	PHP 25XH200TB
26	183,93	181,13	198	6F	2517	16	60	-	65,1	45	7,40	PHP 26XH200TB
27	191,01	188,21	212	7F	2517	16	60	134	65,1	45	8,20	PHP 27XH200TB
28	198,09	195,29	226	7F	2517	16	60	134	65,1	45	9,00	PHP 28XH200TB
30	212,23	209,43	226	7F	2517	16	60	134	65,1	45	9,60	PHP 30XH200TB
32	226,38	223,58	240	7F	2517	16	60	134	65,1	45	9,80	PHP 32XH200TB
36	254,64	251,84	267	8F	2517	16	60	134	65,1	45	11,60	PHP 36XH200TB
40	282,98	280,18	-	8	2517	16	60	134	65,1	45	13,30	PHP 40XH200TB
48	339,57	336,77	-	8	3020	25	75	165	65,1	51	19,00	PHP 48XH200TB
60	424,47	421,67	-	8	3020	25	75	165	65,1	51	22,00	PHP 60XH200TB



Classical timing pulleys

Taper bushed

- ▶ Belts
- ▶ Chains
- ▶ Couplings
- ▶ Bushings and Hubs
- ▶ Sprockets
- ▶ Pulleys
- ▶ Smart tools

XH

7/8" Pitch (22,25 mm)

Type 6F

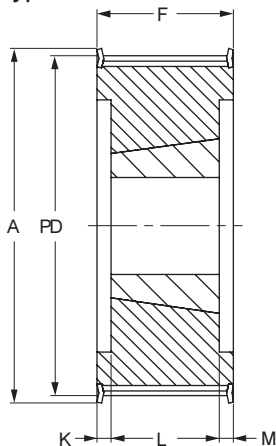

Type 7F

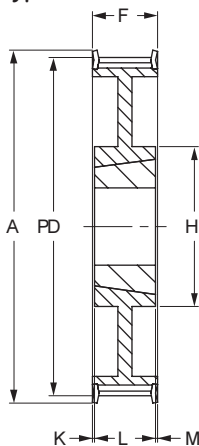

Type 8

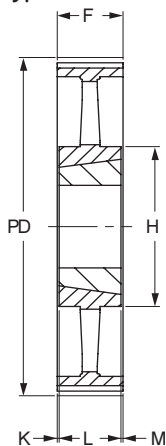

XH 300

For Belt Width 76,2 mm

No. Teeth	Diameter			Type	Bush	Bore		Dimensions			Weight	Designation
	P.D.	O.D.	A			Min	Max	H	F	L		
	mm	mm	mm			mm	mm	mm	mm	mm		
18	127,34	124,54	141	6F	2012	14	50	-	92,1	45	3,7	PHP 18XH300TB
19	134,41	131,61	146	6F	2517	16	60	-	92,1	45	4,2	PHP 19XH300TB
20	141,49	138,69	155	6F	2517	16	60	-	92,1	45	4,7	PHP 20XH300TB
21	148,56	145,76	169	6F	2517	16	60	-	92,1	45	5,4	PHP 21XH300TB
22	155,64	152,84	169	6F	2517	16	60	-	92,1	45	6,0	PHP 22XH300TB
24	169,79	166,99	183	6F	2517	16	60	-	92,1	45	7,6	PHP 24XH300TB
25	176,86	174,06	198	6F	2517	16	60	-	92,1	45	8,7	PHP 25XH300TB
26	183,93	181,13	198	6F	2517	16	60	-	92,1	45	9,8	PHP 26XH300TB
27	191,01	188,21	212	6F	2517	16	60	-	92,1	45	10,7	PHP 27XH300TB
28	198,09	195,29	212	7F	2517	16	60	134	92,1	45	11,6	PHP 28XH300TB
30	212,23	209,43	226	7F	2517	16	60	134	92,1	45	11,9	PHP 30XH300TB
32	226,38	223,58	240	7F	3020	25	75	165	92,1	51	13,8	PHP 32XH300TB
36	254,64	251,84	267	7F	3020	25	75	165	92,1	51	16,7	PHP 36XH300TB
40	282,98	280,18	-	8	3020	25	75	165	92,1	51	19,5	PHP 40XH300TB
48	339,57	336,77	-	8	3020	25	75	165	92,1	51	27,0	PHP 48XH300TB
60	424,47	421,67	-	8	3535	35	90	184	92,1	89	28,0	PHP 60XH300TB

XH 400

For Belt Width 101,6 mm

No. Teeth	Diameter			Type	Bush	Bore		Dimensions			Weight	Designation
	P.D.	O.D.	A			Min	Max	H	F	L		
	mm	mm	mm			mm	mm	mm	mm	mm		
18	127,34	124,54	141	6F	2012	16	60	-	92,1	45	5,0	PHP 18XH400TB
19	134,41	131,61	146	6F	2517	16	60	-	92,1	45	5,5	PHP 19XH400TB
20	141,49	138,69	155	6F	2517	16	60	-	92,1	45	6,0	PHP 20XH400TB
21	148,56	145,76	169	6F	2517	16	60	-	92,1	45	6,6	PHP 21XH400TB
22	155,64	152,84	169	6F	2517	16	60	-	92,1	45	7,2	PHP 22XH400TB
24	169,79	166,99	183	6F	3020	25	75	-	92,1	51	8,4	PHP 24XH400TB
25	176,86	174,06	198	6F	3020	25	75	-	92,1	51	9,4	PHP 25XH400TB
26	183,93	181,13	198	6F	3020	25	75	-	92,1	51	10,3	PHP 26XH400TB
27	191,01	188,21	212	6F	3020	25	75	-	92,1	51	11,3	PHP 27XH400TB
28	198,09	195,29	212	6F	3020	25	75	-	92,1	51	12,3	PHP 28XH400TB
30	212,23	209,43	226	6F	3020	25	75	-	92,1	51	14,3	PHP 30XH400TB
32	226,38	223,58	240	7F	3020	25	75	165	92,1	51	19,9	PHP 32XH400TB
36	254,64	251,84	267	7F	3020	25	75	165	92,1	51	22,3	PHP 36XH400TB
40	282,98	280,18	-	8	3020	25	75	165	92,1	51	24,6	PHP 40XH400TB
48	339,57	336,77	-	8	3535	35	90	184	92,1	89	30,0	PHP 48XH400TB
60	424,47	421,67	-	8	3535	35	90	184	92,1	89	40,0	PHP 60XH400TB



Metric timing pulleys



Type T
Pilot bore (RSB)

2,5 mm Pitch

Type 0F

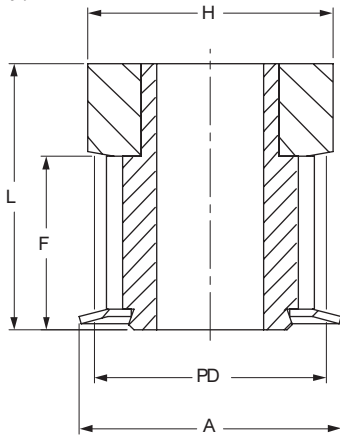

Type 1

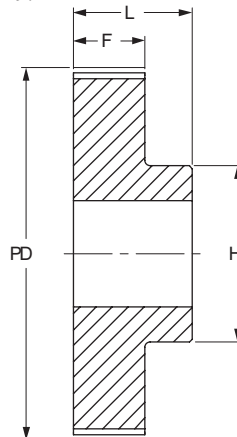

Type 1F

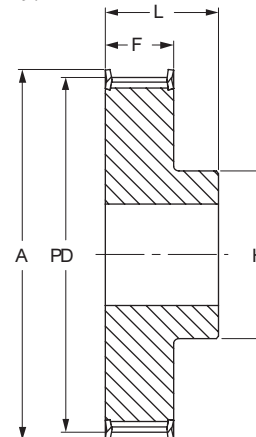

Belt Width 4 mm & 6 mm

No. Teeth	Diameter			Type	Bore		Dimensions			Weight kg	Designation
	P.D.	O.D.	A		Min	Max	F	H	L		
	mm	mm	mm		mm	mm	mm	mm	mm		
10	7,96	7,45	10	0F	-	3	10	10	16	0,00	PHP 16-T2,5-10RSB
11	8,75	8,25	12	0F	-	3	10	11	16	0,00	PHP 16-T2,5-11RSB
12	9,54	9,00	13	0F	-	4	10	13	16	0,00	PHP 16-T2,5-12RSB
13	10,35	9,95	14	0F	-	4	10	14	16	0,00	PHP 16-T2,5-13RSB
14	11,14	10,60	15	0F	-	5	10	15	16	0,00	PHP 16-T2,5-14RSB
15	11,94	11,40	15	0F	-	6	10	15	16	0,01	PHP 16-T2,5-15RSB
16	12,73	12,20	16	0F	-	7	10	16	16	0,01	PHP 16-T2,5-16RSB
17	13,53	13,00	17	0F	4	7	10	16	16	0,01	PHP 16-T2,5-17RSB
18	14,32	13,80	18	1F	4	7	10	10	16	0,01	PHP 16-T2,5-18RSB
19	15,12	14,60	18	1F	4	7	10	10	16	0,01	PHP 16-T2,5-19RSB
20	15,92	15,40	20	1F	4	7	10	11	16	0,01	PHP 16-T2,5-20RSB
21	16,71	16,20	20	1F	4	7	10	11	16	0,01	PHP 16-T2,5-21RSB
22	17,51	17,00	23	1F	4	7	10	10	16	0,01	PHP 16-T2,5-22RSB
23	18,30	17,80	23	1F	4	8	10	12	16	0,01	PHP 16-T2,5-23RSB
24	19,10	18,55	23	1F	4	8	10	12	16	0,01	PHP 16-T2,5-24RSB
25	19,89	19,35	23	1F	4	9	10	13	16	0,01	PHP 16-T2,5-25RSB
26	20,69	20,15	25	1F	4	9	10	14	16	0,01	PHP 16-T2,5-26RSB
27	21,49	20,90	25	1F	4	9	10	14	16	0,02	PHP 16-T2,5-27RSB
28	22,28	21,75	25	1F	4	9	10	14	16	0,02	PHP 16-T2,5-28RSB
30	23,87	23,35	28	1F	6	10	10	16	16	0,02	PHP 16-T2,5-30RSB
32	25,46	24,95	32	1F	6	10	10	16	16	0,02	PHP 16-T2,5-32RSB
35	27,85	27,35	36	1F	6	10	10	18	16	0,02	PHP 16-T2,5-35RSB
36	28,65	28,10	36	1F	6	13	10	20	16	0,03	PHP 16-T2,5-36RSB
38	30,24	29,70	38	1F	6	13	10	22	16	0,03	PHP 16-T2,5-38RSB
40	31,83	31,30	38	1F	6	13	10	22	16	0,03	PHP 16-T2,5-40RSB
42	33,42	32,90	42	1F	6	15	10	24	16	0,04	PHP 16-T2,5-42RSB
44	35,01	34,50	-	1	6	15	10	24	16	0,04	PHP 16-T2,5-44RSB
45	35,81	35,30	-	1	6	17	10	26	16	0,04	PHP 16-T2,5-45RSB
48	38,20	37,70	-	1	6	17	10	26	16	0,05	PHP 16-T2,5-48RSB
54	42,97	42,45	-	1	8	19	10	30	16	0,06	PHP 16-T2,5-54RSB
57	45,36	44,85	-	1	8	19	10	32	16	0,06	PHP 16-T2,5-57RSB
60	47,75	47,25	-	1	8	22	10	34	16	0,07	PHP 16-T2,5-60RSB



Metric timing pulleys

Type T

Pilot bore (RSB)

- ▶ Belts
- ▶ Chains
- ▶ Couplings
- ▶ Bushings and Hubs
- ▶ Sprockets
- ▶ Pulleys
- ▶ Smart tools

2,5 mm Pitch

Type 0F

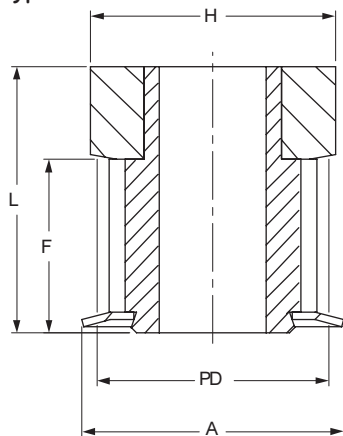

Type 1

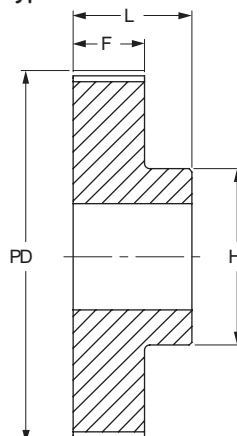

Type 1F

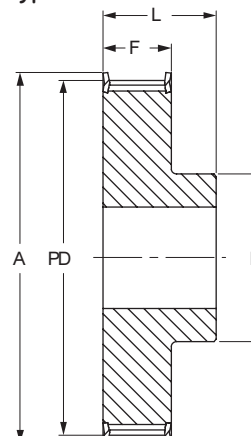

Belt Width 10 mm

No. Teeth	Diameter			Type	Bore		Dimensions			Weight	Designation
	P.D.	O.D.	A		Min	Max	F	H	L		
	mm	mm	mm		mm	mm	mm	mm	mm		
10	7,96	7,45	10	0F	3	3	14	10	20	0,01	PHP 20-T2,5-10RSB
11	8,75	8,25	12	0F	3	3	14	11	20	0,01	PHP 20-T2,5-11RSB
12	9,55	9,00	13	0F	3	4	14	13	20	0,02	PHP 20-T2,5-12RSB
13	10,35	9,95	14	0F	3	4	14	14	20	0,02	PHP 20-T2,5-13RSB
14	11,14	10,60	14	0F	3	5	14	15	20	0,02	PHP 20-T2,5-14RSB
15	11,94	11,40	15	0F	3	6	14	15	20	0,02	PHP 20-T2,5-15RSB
16	12,73	12,20	16	0F	4	7	14	16	20	0,03	PHP 20-T2,5-16RSB
17	13,53	13,00	17	1F	4	7	14	16	20	0,02	PHP 20-T2,5-17RSB
18	14,32	13,80	17	1F	4	7	14	10	20	0,03	PHP 20-T2,5-18RSB
19	15,12	14,60	18	1F	4	7	14	10	20	0,04	PHP 20-T2,5-19RSB
20	15,92	15,40	19	1F	4	7	14	11	20	0,04	PHP 20-T2,5-20RSB
21	16,71	16,20	20	1F	4	7	14	11	20	0,04	PHP 20-T2,5-21RSB
22	17,60	17,00	22	1F	4	7	14	11	20	0,05	PHP 20-T2,5-22RSB
23	18,30	17,80	22	1F	4	8	14	12	20	0,05	PHP 20-T2,5-23RSB
24	19,10	18,55	22	1F	4	8	14	12	20	0,05	PHP 20-T2,5-24RSB
25	19,89	19,35	24	1F	4	9	14	13	20	0,06	PHP 20-T2,5-25RSB
26	20,75	20,15	26	1F	4	9	14	14	20	0,06	PHP 20-T2,5-26RSB
27	21,49	20,90	26	1F	4	9	14	14	20	0,06	PHP 20-T2,5-27RSB
28	22,35	21,75	26	1F	4	9	14	14	20	0,07	PHP 20-T2,5-28RSB
30	23,87	23,35	28	1F	6	10	14	16	20	0,08	PHP 20-T2,5-30RSB
32	25,47	24,95	28	1F	6	10	14	16	20	0,09	PHP 20-T2,5-32RSB
35	27,85	27,35	32	1F	6	10	14	18	20	0,11	PHP 20-T2,5-35RSB
36	28,65	28,10	32	1F	6	13	14	20	20	0,11	PHP 20-T2,5-36RSB
38	30,24	29,70	34	1F	6	13	14	22	20	0,13	PHP 20-T2,5-38RSB
40	31,83	31,30	35	1F	6	13	14	22	20	0,14	PHP 20-T2,5-40RSB
42	33,42	32,90	-	1	6	15	14	24	20	0,18	PHP 20-T2,5-42RSB
44	35,01	34,50	-	1	6	15	14	24	20	0,19	PHP 20-T2,5-44RSB
45	35,81	35,30	-	1	6	17	14	26	20	0,19	PHP 20-T2,5-45RSB
48	38,20	37,70	-	1	6	17	14	26	20	0,20	PHP 20-T2,5-48RSB
54	42,97	42,45	-	1	8	19	14	30	20	0,25	PHP 20-T2,5-54RSB
57	45,36	44,85	-	1	8	19	14	32	20	0,28	PHP 20-T2,5-57RSB
60	47,75	47,25	-	1	8	22	14	34	20	0,31	PHP 20-T2,5-60RSB



Metric timing pulleys



Type T
Pilot bore (RSB)

5 mm Pitch

Type 1

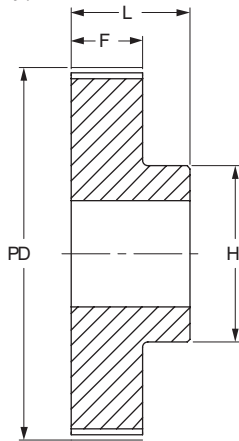

Type 1F

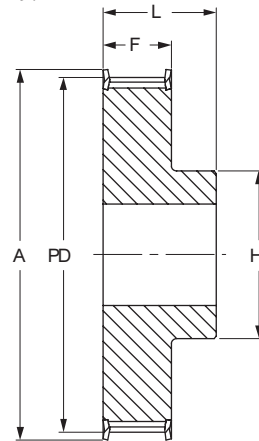

Belt Width 10 mm

No. Teeth	Diameter			Type	Bore		Dimensions			Weight	Designation
	P.D.	O.D.	A		Min	Max	F	H	L		
	mm	mm	mm		mm	mm	mm	mm	mm		
10	15,92	15,05	20	1F	4	5	15	8	21	0,01	PHP 21-T5-10RSB
11	17,51	16,65	22	1F	4	6	15	10	21	0,01	PHP 21-T5-11RSB
12	19,10	18,25	23	1F	4	7	15	12	21	0,02	PHP 21-T5-12RSB
13	20,69	19,85	25	1F	6	8	15	13	21	0,02	PHP 21-T5-13RSB
14	22,29	21,45	26	1F	6	9	15	14	21	0,02	PHP 21-T5-14RSB
15	23,88	23,05	28	1F	6	10	15	16	21	0,02	PHP 21-T5-15RSB
16	25,47	24,60	30	1F	6	11	15	18	21	0,03	PHP 21-T5-16RSB
17	27,06	26,20	32	1F	6	12	15	19	21	0,03	PHP 21-T5-17RSB
18	28,65	27,80	32	1F	6	13	15	20	21	0,03	PHP 21-T5-18RSB
19	30,25	29,40	36	1F	6	14	15	22	21	0,04	PHP 21-T5-19RSB
20	31,83	31,00	36	1F	6	15	15	24	21	0,04	PHP 21-T5-20RSB
21	33,42	32,55	38	1F	6	15	15	24	21	0,04	PHP 21-T5-21RSB
22	35,01	34,15	38	1F	6	15	15	24	21	0,05	PHP 21-T5-22RSB
23	36,61	35,75	42	1F	6	16	15	25	21	0,05	PHP 21-T5-23RSB
24	38,21	37,40	44	1F	6	17	15	26	21	0,05	PHP 21-T5-24RSB
25	39,80	38,95	44	1F	6	17	15	26	21	0,06	PHP 21-T5-25RSB
26	41,45	40,60	44	1F	6	17	15	26	21	0,06	PHP 21-T5-26RSB
27	42,98	42,20	48	1F	8	19	15	30	21	0,06	PHP 21-T5-27RSB
28	44,56	43,75	48	1F	8	20	15	32	21	0,06	PHP 21-T5-28RSB
30	47,76	46,95	51	1F	8	22	15	34	21	0,08	PHP 21-T5-30RSB
32	50,94	50,10	54	1F	8	24	15	38	21	0,09	PHP 21-T5-32RSB
35	55,70	54,85	59	1F	8	24	15	38	21	0,10	PHP 21-T5-35RSB
36	57,31	56,45	63	1F	8	24	15	38	21	0,11	PHP 21-T5-36RSB
38	60,48	59,65	66	1F	8	26	15	40	21	0,13	PHP 21-T5-38RSB
40	63,66	62,85	66	1F	8	26	15	40	21	0,14	PHP 21-T5-40RSB
42	66,84	66,00	71	1F	8	26	15	40	21	0,18	PHP 21-T5-42RSB
44	70,20	69,35	-	1	8	29	15	45	21	0,19	PHP 21-T5-44RSB
45	71,62	70,80	-	1	8	31	15	45	21	0,19	PHP 21-T5-45RSB
48	76,39	75,55	-	1	8	32	15	50	21	0,20	PHP 21-T5-48RSB
54	85,94	85,10	-	1	8	35	15	55	21	0,24	PHP 21-T5-54RSB
57	90,72	89,90	-	1	8	38	15	60	21	0,27	PHP 21-T5-57RSB
60	95,49	94,65	-	1	8	42	15	65	21	0,31	PHP 21-T5-60RSB



Metric timing pulleys

Type T

Pilot bore (RSB)

- ▶ Belts
- ▶ Chains
- ▶ Couplings
- ▶ Bushings and Hubs
- ▶ Sprockets
- ▶ Pulleys
- ▶ Smart tools

5 mm Pitch

Type 1

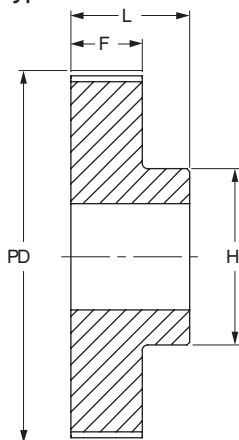

Type 1F

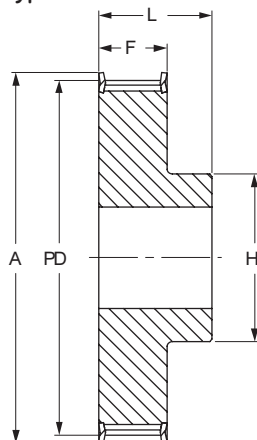

Belt Width 16 mm

No. Teeth	Diameter			Type	Bore		Dimensions			Weight	Designation
	P.D.	O.D.	A		Min	Max	F	H	L		
	mm	mm	mm		mm	mm	mm	mm	mm		
10	15,92	15,05	20	1F	4	5	21	8	27	0,02	PHP 27-T5-10RSB
11	17,51	16,65	22	1F	4	6	21	10	27	0,02	PHP 27-T5-11RSB
12	19,10	18,25	23	1F	4	7	21	12	27	0,02	PHP 27-T5-12RSB
13	20,69	19,85	25	1F	6	8	21	13	27	0,02	PHP 27-T5-13RSB
14	22,29	21,45	26	1F	6	9	21	14	27	0,03	PHP 27-T5-14RSB
15	23,88	23,05	28	1F	6	10	21	16	27	0,03	PHP 27-T5-15RSB
16	25,47	24,60	32	1F	6	11	21	18	27	0,04	PHP 27-T5-16RSB
17	27,06	26,20	32	1F	6	12	21	19	27	0,04	PHP 27-T5-17RSB
18	28,65	27,80	33	1F	6	13	21	20	27	0,05	PHP 27-T5-18RSB
19	30,25	29,40	36	1F	6	14	21	22	27	0,05	PHP 27-T5-19RSB
20	31,83	31,00	36	1F	6	15	21	24	27	0,05	PHP 27-T5-20RSB
21	33,42	32,55	38	1F	6	15	21	24	27	0,05	PHP 27-T5-21RSB
22	35,01	34,15	38	1F	6	15	21	24	27	0,05	PHP 27-T5-22RSB
23	36,61	35,75	42	1F	6	16	21	25	27	0,06	PHP 27-T5-23RSB
24	38,21	37,40	42	1F	6	17	21	26	27	0,08	PHP 27-T5-24RSB
25	39,80	38,95	44	1F	6	17	21	26	27	0,08	PHP 27-T5-25RSB
26	41,45	40,60	44	1F	6	17	21	26	27	0,09	PHP 27-T5-26RSB
27	42,98	42,20	48	1F	8	19	21	30	27	0,09	PHP 27-T5-27RSB
28	44,56	43,75	48	1F	8	20	21	32	27	0,09	PHP 27-T5-28RSB
30	47,76	46,95	51	1F	8	22	21	34	27	0,11	PHP 27-T5-30RSB
32	50,94	50,10	54	1F	8	24	21	38	27	0,12	PHP 27-T5-32RSB
35	55,70	54,85	59	1F	8	24	21	38	27	0,14	PHP 27-T5-35RSB
36	57,31	56,45	63	1F	8	24	21	38	27	0,16	PHP 27-T5-36RSB
38	60,48	59,65	66	1F	8	26	21	40	27	0,18	PHP 27-T5-38RSB
40	63,66	62,85	66	1F	8	26	21	40	27	0,19	PHP 27-T5-40RSB
42	66,84	66,00	71	1F	8	26	21	40	27	0,21	PHP 27-T5-42RSB
44	70,20	69,35	-	1	8	29	21	45	27	0,23	PHP 27-T5-44RSB
45	71,62	70,80	-	1	8	29	21	45	27	0,26	PHP 27-T5-45RSB
48	76,39	75,55	-	1	8	32	21	50	27	0,28	PHP 27-T5-48RSB
54	85,94	85,10	-	1	8	35	21	55	27	0,33	PHP 27-T5-54RSB
57	90,72	89,90	-	1	8	38	21	60	27	0,38	PHP 27-T5-57RSB
60	95,49	94,65	-	1	8	42	21	65	27	0,43	PHP 27-T5-60RSB



Metric timing pulleys



Type T
Pilot bore (RSB)

5 mm Pitch

Type 1

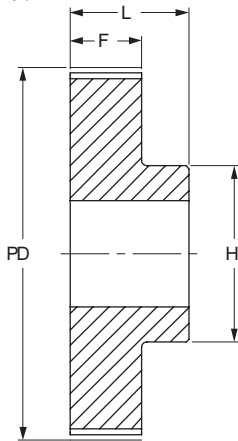

Type 1F

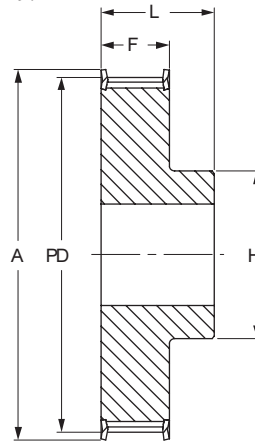

Belt Width 25 mm

No. Teeth	Diameter			Type	Bore		Dimensions			Weight	Designation
	P.D.	O.D.	A		Min	Max	F	H	L		
	mm	mm	mm		mm	mm	mm	mm	mm		
10	15,92	15,05	20	1F	5	4	30	8	36	0,02	PHP 36-T5-10RSB
11	17,51	16,65	22	1F	6	4	30	10	36	0,03	PHP 36-T5-11RSB
12	19,10	18,25	23	1F	7	4	30	12	36	0,03	PHP 36-T5-12RSB
13	20,69	19,85	25	1F	8	6	30	13	36	0,03	PHP 36-T5-13RSB
14	22,29	21,45	26	1F	9	6	30	14	36	0,04	PHP 36-T5-14RSB
15	23,88	23,05	28	1F	10	6	30	16	36	0,04	PHP 36-T5-15RSB
16	25,47	24,60	32	1F	11	6	30	18	36	0,05	PHP 36-T5-16RSB
17	27,06	26,20	32	1F	12	6	30	19	36	0,06	PHP 36-T5-17RSB
18	28,65	27,80	32	1F	13	6	30	20	36	0,06	PHP 36-T5-18RSB
19	30,25	29,40	36	1F	14	6	30	22	36	0,07	PHP 36-T5-19RSB
20	31,83	31,00	36	1F	15	6	30	24	36	0,08	PHP 36-T5-20RSB
21	33,42	32,55	38	1F	15	6	30	24	36	0,08	PHP 36-T5-21RSB
22	35,01	34,15	38	1F	15	6	30	24	36	0,08	PHP 36-T5-22RSB
23	36,61	35,75	42	1F	15	6	30	25	36	0,09	PHP 36-T5-23RSB
24	38,21	37,40	42	1F	17	6	30	26	36	0,11	PHP 36-T5-24RSB
25	39,80	38,95	44	1F	17	6	30	26	36	0,12	PHP 36-T5-25RSB
26	41,45	40,60	44	1F	17	6	30	26	36	0,12	PHP 36-T5-26RSB
27	42,98	42,20	48	1F	19	8	30	30	36	0,13	PHP 36-T5-27RSB
28	44,56	43,75	48	1F	20	8	30	32	36	0,13	PHP 36-T5-28RSB
30	47,76	46,95	51	1F	22	8	30	34	36	0,15	PHP 36-T5-30RSB
32	50,94	50,10	54	1F	24	8	30	38	36	0,18	PHP 36-T5-32RSB
35	55,70	54,85	59	1F	24	8	30	38	36	0,21	PHP 36-T5-35RSB
36	57,31	56,45	63	1F	24	8	30	38	36	0,23	PHP 36-T5-36RSB
38	60,48	59,65	66	1F	26	8	30	40	36	0,25	PHP 36-T5-38RSB
40	63,66	62,85	66	1F	26	8	30	40	36	0,28	PHP 36-T5-40RSB
42	66,84	66,00	71	1F	26	8	30	40	36	0,28	PHP 36-T5-42RSB
44	70,20	69,35	-	1	29	8	30	45	36	0,32	PHP 36-T5-44RSB
45	71,62	70,80	-	1	29	8	30	45	36	0,36	PHP 36-T5-45RSB
48	76,39	75,55	-	1	32	8	30	50	36	0,40	PHP 36-T5-48RSB
54	85,94	85,10	-	1	35	8	30	55	36	0,47	PHP 36-T5-54RSB
57	90,72	89,90	-	1	38	8	30	60	36	0,54	PHP 36-T5-57RSB
60	95,49	94,65	-	1	42	8	30	65	36	0,61	PHP 36-T5-60RSB



Metric timing pulleys

Type T

Pilot bore (RSB)

- ▶ Belts
- ▶ Chains
- ▶ Couplings
- ▶ Bushings and Hubs
- ▶ Sprockets
- ▶ Pulleys
- ▶ Smart tools

10 mm Pitch

Type 1

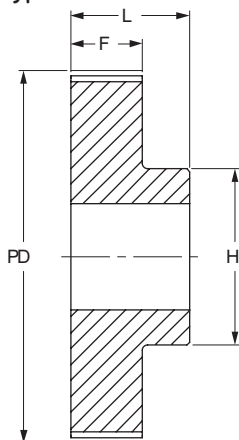

Type 1F

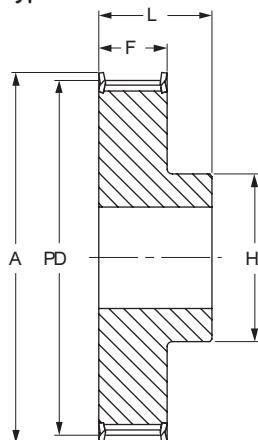

Belt Width 16 mm

No. Teeth	Diameter			Type	Bore		Dimensions			Weight	Designation
	P.D.	O.D.	A		Min	Max	F	H	L		
	mm	mm	mm		mm	mm	mm	mm	mm		
12	38,20	36,35	42	1F	6	18	21	28	31	0,08	PHP 31-T10-12RSB
13	41,38	39,55	44	1F	6	19	21	32	31	0,09	PHP 31-T10-13RSB
14	44,56	42,70	48	1F	8	21	21	32	31	0,10	PHP 31-T10-14RSB
15	47,75	45,90	51	1F	8	21	21	32	31	0,12	PHP 31-T10-15RSB
16	50,93	49,10	54	1F	8	23	21	35	31	0,13	PHP 31-T10-16RSB
17	54,11	52,25	58	1F	8	24	21	38	31	0,15	PHP 31-T10-17RSB
18	57,29	55,45	60	1F	8	26	21	40	31	0,17	PHP 31-T10-18RSB
19	60,48	58,65	66	1F	8	28	21	44	31	0,18	PHP 31-T10-19RSB
20	63,66	61,80	66	1F	8	30	21	46	31	0,21	PHP 31-T10-20RSB
21	66,85	65,00	71	1F	8	36	21	48	31	0,23	PHP 31-T10-21RSB
22	70,03	68,20	75	1F	8	34	21	52	31	0,25	PHP 31-T10-22RSB
23	73,21	71,35	77	1F	8	36	21	55	31	0,27	PHP 31-T10-23RSB
24	76,39	74,55	83	1F	8	38	21	58	31	0,29	PHP 31-T10-24RSB
25	79,58	77,75	83	1F	8	39	21	60	31	0,31	PHP 31-T10-25RSB
26	82,76	80,90	87	1F	8	39	21	60	31	0,36	PHP 31-T10-26RSB
27	85,95	84,10	91	1F	8	39	21	60	31	0,36	PHP 31-T10-27RSB
28	89,25	87,25	93	1F	8	39	21	60	31	0,40	PHP 31-T10-28RSB
30	95,49	93,65	99	1F	8	39	21	60	31	0,44	PHP 31-T10-30RSB
32	101,86	100,00	106	1F	10	42	21	65	31	0,49	PHP 31-T10-32RSB
35	111,41	109,55	115	1F	10	45	21	70	31	0,56	PHP 31-T10-35RSB
36	114,59	112,75	119	1F	10	45	21	70	31	0,62	PHP 31-T10-36RSB
38	120,96	119,10	125	1F	10	48	21	75	31	0,69	PHP 31-T10-38RSB
40	127,32	125,45	131	1F	10	52	21	80	31	0,77	PHP 31-T10-40RSB
42	133,69	131,85	-	1	10	52	21	80	31	0,88	PHP 31-T10-42RSB
44	140,06	138,20	-	1	10	57	21	88	31	0,99	PHP 31-T10-44RSB
45	143,24	141,40	-	1	16	57	21	90	31	1,04	PHP 31-T10-45RSB
48	152,78	150,95	-	1	16	62	21	95	31	1,09	PHP 31-T10-48RSB
54	171,89	170,05	-	1	16	66	21	100	31	1,30	PHP 31-T10-54RSB
57	181,44	179,60	-	1	16	66	21	110	31	1,50	PHP 31-T10-57RSB
60	190,98	189,15	-	1	16	72	21	110	31	1,71	PHP 31-T10-60RSB



Metric timing pulleys



Type T
Pilot bore (RSB)

10 mm Pitch

Type 1

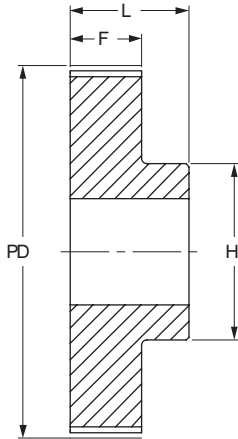

Type 1F

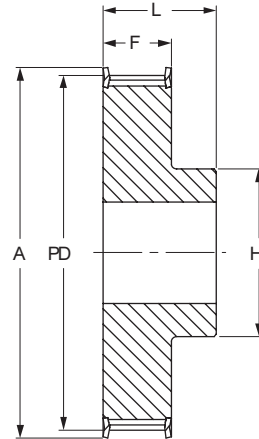

Belt Width 25 mm

No. Teeth	Diameter			Type	Bore		Dimensions			Weight	Designation
	P.D.	O.D.	A		Min	Max	F	H	L		
	mm	mm	mm		mm	mm	mm	mm	mm		
12	38,20	36,35	42	1F	6	18	30	28	40	0,10	PHP 40-T10-12RSB
13	41,38	39,55	44	1F	6	19	30	30	40	0,12	PHP 40-T10-13RSB
14	44,56	42,70	48	1F	8	21	30	32	40	0,13	PHP 40-T10-14RSB
15	47,75	45,90	51	1F	8	21	30	32	40	0,15	PHP 40-T10-15RSB
16	50,93	49,10	54	1F	8	23	30	35	40	0,18	PHP 40-T10-16RSB
17	54,11	52,25	58	1F	8	24	30	37	40	0,20	PHP 40-T10-17RSB
18	57,29	55,45	60	1F	8	26	30	40	40	0,22	PHP 40-T10-18RSB
19	60,48	58,65	66	1F	8	28	30	44	40	0,25	PHP 40-T10-19RSB
20	63,66	61,80	66	1F	8	30	30	46	40	0,28	PHP 40-T10-20RSB
21	66,85	65,00	71	1F	8	32	30	49	40	0,30	PHP 40-T10-21RSB
22	70,03	68,20	75	1F	8	34	30	52	40	0,34	PHP 40-T10-22RSB
23	73,21	71,35	77	1F	8	36	30	55	40	0,36	PHP 40-T10-23RSB
24	76,39	74,55	83	1F	8	38	30	58	40	0,39	PHP 40-T10-24RSB
25	79,58	77,75	83	1F	8	39	30	60	40	0,42	PHP 40-T10-25RSB
26	82,76	80,90	87	1F	8	39	30	60	40	0,48	PHP 40-T10-26RSB
27	85,95	84,10	91	1F	8	39	30	60	40	0,54	PHP 40-T10-27RSB
28	89,25	87,25	93	1F	8	39	30	60	40	0,54	PHP 40-T10-28RSB
30	95,49	93,65	99	1F	8	39	30	60	40	0,64	PHP 40-T10-30RSB
32	101,86	100,00	106	1F	10	42	30	65	40	0,69	PHP 40-T10-32RSB
35	111,41	109,55	115	1F	10	45	30	70	40	0,78	PHP 40-T10-35RSB
36	114,59	112,75	119	1F	10	45	30	70	40	0,87	PHP 40-T10-36RSB
38	120,96	119,10	125	1F	10	48	30	75	40	0,97	PHP 40-T10-38RSB
40	127,32	125,45	131	1F	10	52	30	80	40	1,07	PHP 40-T10-40RSB
42	133,69	131,85	-	1	10	52	30	80	40	1,21	PHP 40-T10-42RSB
44	140,06	138,20	-	1	10	57	30	88	40	1,35	PHP 40-T10-44RSB
45	143,24	141,40	-	1	16	59	30	90	40	1,43	PHP 40-T10-45RSB
48	152,78	150,95	-	1	16	62	30	95	40	1,52	PHP 40-T10-48RSB
54	171,89	170,05	-	1	16	65	30	100	40	1,79	PHP 40-T10-54RSB
57	181,44	179,60	-	1	16	72	30	110	40	2,06	PHP 40-T10-57RSB
60	190,98	189,15	-	1	16	72	30	110	40	2,34	PHP 40-T10-60RSB



Metric timing pulleys

Type T

Pilot bore (RSB)

- ▶ Belts
- ▶ Chains
- ▶ Couplings
- ▶ Bushings and Hubs
- ▶ Sprockets
- ▶ Pulleys
- ▶ Smart tools

10 mm Pitch

Type 1

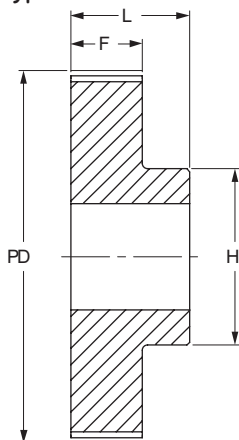

Type 1F

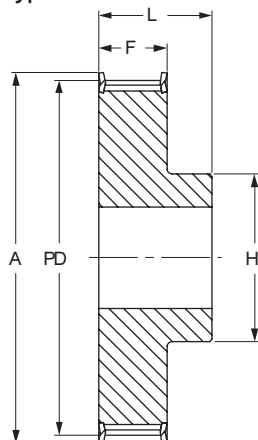

Belt Width 32 mm

No. Teeth	Diameter			Type	Bore		Dimensions			Weight	Designation
	P.D.	O.D.	A		Min	Max	F	H	L		
	mm	mm	mm		mm	mm	mm	mm	mm		
18	57,30	55,45	60	1F	10	26	37	40	47	0,25	PHP 47-T10-18RSB
19	60,48	58,65	66	1F	10	28	37	44	47	0,29	PHP 47-T10-19RSB
20	63,66	61,80	66	1F	12	30	37	46	47	0,32	PHP 47-T10-20RSB
21	66,85	65,00	71	1F	12	32	37	49	47	0,36	PHP 47-T10-21RSB
22	70,03	68,20	75	1F	12	34	37	52	47	0,39	PHP 47-T10-22RSB
23	73,21	71,35	77	1F	12	36	37	55	47	0,43	PHP 47-T10-23RSB
24	76,39	74,55	83	1F	12	38	37	58	47	0,48	PHP 47-T10-24RSB
25	79,58	77,75	83	1F	12	39	37	60	47	0,53	PHP 47-T10-25RSB
26	82,76	80,90	87	1F	12	39	37	60	47	0,56	PHP 47-T10-26RSB
27	85,94	84,10	91	1F	12	39	37	60	47	0,60	PHP 47-T10-27RSB
28	89,13	87,25	93	1F	12	39	37	60	47	0,64	PHP 47-T10-28RSB
30	95,49	93,65	99	1F	12	39	37	60	47	0,74	PHP 47-T10-30RSB
32	101,86	100,00	106	1F	12	42	37	65	47	0,84	PHP 47-T10-32RSB
35	111,41	109,55	115	1F	16	45	37	70	47	0,96	PHP 47-T10-35RSB
36	114,59	112,75	119	1F	16	45	37	70	47	1,08	PHP 47-T10-36RSB
38	120,96	119,10	125	1F	16	48	37	75	47	1,20	PHP 47-T10-38RSB
40	127,32	125,45	131	1F	16	52	37	80	47	1,32	PHP 47-T10-40RSB
42	133,69	131,85	-	1	16	52	37	80	47	1,46	PHP 47-T10-42RSB
44	140,06	138,20	-	1	16	57	37	88	47	1,61	PHP 47-T10-44RSB
45	143,24	141,40	-	1	16	58	37	90	47	1,77	PHP 47-T10-45RSB
48	152,79	150,95	-	1	16	62	37	95	47	1,93	PHP 47-T10-48RSB
54	171,89	170,05	-	1	16	65	37	100	47	2,29	PHP 47-T10-54RSB
57	181,44	179,60	-	1	16	72	37	110	47	2,65	PHP 47-T10-57RSB
60	190,99	189,15	-	1	16	72	37	110	47	3,00	PHP 47-T10-60RSB



Metric timing pulleys



Type T
Pilot bore (RSB)

10 mm Pitch

Type 1

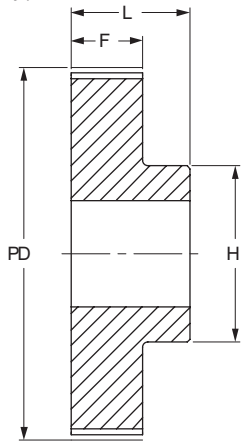

Type 1F

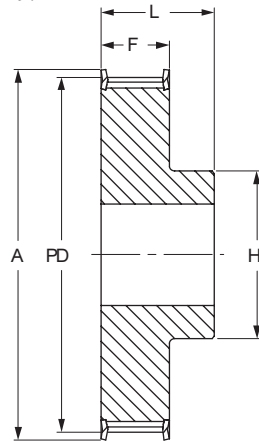

Belt Width 50 mm

No. Teeth	Diameter			Type	Bore		Dimensions			Weight kg	Designation
	P.D.	O.D.	A		Min	Max	F	H	L		
	mm	mm	mm		mm	mm	mm	mm	mm		
18	57,30	55,45	60	1F	10	26	56	40	66	0,42	PHP 66-T10-18RSB
19	60,48	58,65	66	1F	10	28	56	44	66	0,47	PHP 66-T10-19RSB
20	63,66	61,80	66	1F	12	30	56	46	66	0,52	PHP 66-T10-20RSB
21	66,85	65,00	71	1F	12	32	56	49	66	0,55	PHP 66-T10-21RSB
22	70,03	68,20	75	1F	12	34	56	52	66	0,57	PHP 66-T10-22RSB
23	73,21	71,35	77	1F	12	36	56	55	66	0,65	PHP 66-T10-23RSB
24	76,39	74,55	83	1F	12	38	56	58	66	0,74	PHP 66-T10-24RSB
25	79,58	77,75	83	1F	12	39	56	60	66	0,77	PHP 66-T10-25RSB
26	82,76	80,90	87	1F	12	39	56	60	66	0,82	PHP 66-T10-26RSB
27	85,94	84,10	91	1F	12	39	56	60	66	0,95	PHP 66-T10-27RSB
28	89,13	87,25	93	1F	12	39	56	60	66	0,96	PHP 66-T10-28RSB
30	95,49	93,65	99	1F	12	39	56	60	66	1,17	PHP 66-T10-30RSB
32	101,86	100,00	106	1F	12	42	56	65	66	1,30	PHP 66-T10-32RSB
35	111,41	109,55	115	1F	16	45	56	70	66	1,47	PHP 66-T10-35RSB
36	114,59	112,75	119	1F	16	45	56	70	66	1,64	PHP 66-T10-36RSB
38	120,96	119,10	125	1F	16	48	56	75	66	1,82	PHP 66-T10-38RSB
40	127,32	125,45	131	1F	16	52	56	80	66	2,00	PHP 66-T10-40RSB
42	133,69	131,85	-	1	16	57	56	80	66	2,18	PHP 66-T10-42RSB
44	140,06	138,20	-	1	16	52	56	88	66	2,36	PHP 66-T10-44RSB
45	143,24	141,40	-	1	16	58	56	90	66	2,59	PHP 66-T10-45RSB
48	152,79	150,95	-	1	16	62	56	95	66	2,83	PHP 66-T10-48RSB
54	171,89	170,05	-	1	16	65	56	100	66	3,34	PHP 66-T10-54RSB
57	181,44	179,60	-	1	16	72	56	110	66	3,85	PHP 66-T10-57RSB
60	190,99	189,15	-	1	16	72	56	110	66	4,37	PHP 66-T10-60RSB



Metric timing pulleys

Type AT

Pilot bore (RSB)

- ▶ Belts
- ▶ Chains
- ▶ Couplings
- ▶ Bushings and Hubs
- ▶ Sprockets
- ▶ Pulleys
- ▶ Smart tools

5 mm Pitch

Type 1

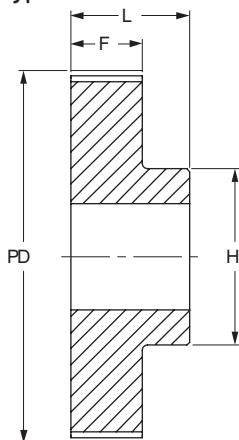

Type 1F

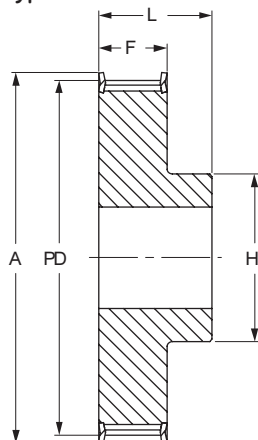

Belt Width 10 mm

No. Teeth	Diameter			Type	Bore		Dimensions			Weight	Designation
	P.D.	O.D.	A		Min	Max	F	H	L		
	mm	mm	mm		mm	mm	mm	mm	mm		
10	15,92	14,65	20	1F	4	5	15	8	21	0,01	PHP 21-AT5-10RSB
12	19,10	17,85	23	1F	4	7	15	12	21	0,02	PHP 21-AT5-12RSB
13	20,69	19,45	25	1F	6	8	15	13	21	0,02	PHP 21-AT5-13RSB
14	22,29	21,05	26	1F	6	9	15	14	21	0,02	PHP 21-AT5-14RSB
15	23,88	22,65	28	1F	6	10	15	16	21	0,02	PHP 21-AT5-15RSB
16	25,47	24,20	32	1F	6	11	15	18	21	0,03	PHP 21-AT5-16RSB
17	27,06	25,80	32	1F	6	12	15	19	21	0,03	PHP 21-AT5-17RSB
18	28,65	27,40	32	1F	6	13	15	20	21	0,03	PHP 21-AT5-18RSB
19	30,25	29,00	36	1F	6	14	15	22	21	0,04	PHP 21-AT5-19RSB
20	31,83	30,60	36	1F	6	15	15	23	21	0,04	PHP 21-AT5-20RSB
21	33,42	32,20	38	1F	6	15	15	24	21	0,04	PHP 21-AT5-21RSB
22	35,02	33,85	38	1F	6	15	15	24	21	0,05	PHP 21-AT5-22RSB
23	36,61	35,40	42	1F	6	17	15	25	21	0,05	PHP 21-AT5-23RSB
24	38,21	37,00	44	1F	6	17	15	26	21	0,05	PHP 21-AT5-24RSB
25	39,80	38,60	44	1F	6	17	15	26	21	0,06	PHP 21-AT5-25RSB
26	41,38	40,20	44	1F	6	17	15	26	21	0,06	PHP 21-AT5-26RSB
27	42,98	41,80	48	1F	8	19	15	30	21	0,06	PHP 21-AT5-27RSB
28	44,56	43,35	48	1F	8	20	15	32	21	0,07	PHP 21-AT5-28RSB
30	47,76	46,55	51	1F	8	22	15	34	21	0,08	PHP 21-AT5-30RSB
32	50,94	49,70	54	1F	8	24	15	38	21	0,09	PHP 21-AT5-32RSB
36	57,31	56,05	63	1F	8	24	15	38	21	0,11	PHP 21-AT5-36RSB
38	60,48	59,25	66	1F	8	26	15	40	21	0,13	PHP 21-AT5-38RSB
40	63,66	62,45	66	1F	8	26	15	40	21	0,14	PHP 21-AT5-40RSB
42	66,74	65,60	71	1F	8	26	15	40	21	0,18	PHP 21-AT5-42RSB
44	70,05	68,80	-	1	8	29	15	45	21	0,19	PHP 21-AT5-44RSB
45	71,62	70,35	-	1	8	29	15	45	21	0,19	PHP 21-AT5-45RSB
48	76,42	75,15	-	1	8	32	15	50	21	0,20	PHP 21-AT5-48RSB
60	95,52	94,25	-	1	8	37	15	65	21	0,31	PHP 21-AT5-60RSB
72	114,62	113,15	-	1	10	42	15	80	21	0,41	PHP 21-AT5-72RSB



Metric timing pulleys



Type AT
Pilot bore (RSB)

5 mm Pitch

Type 1

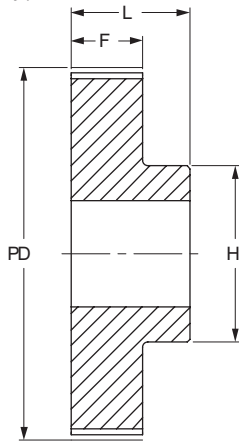

Type 1F

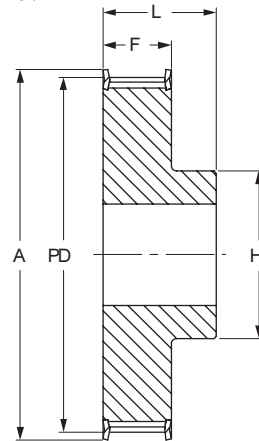

Belt Width 16 mm

No. Teeth	Diameter			Type	Bore		Dimensions			Weight kg	Designation
	P.D.	O.D.	A		Min	Max	F	H	L		
	mm	mm	mm		mm	mm	mm	mm	mm		
10	15,92	14,65	20	1F	4	5	21	8	27	0,02	PHP 27-AT5-10RSB
12	19,10	17,85	23	1F	4	7	21	12	27	0,02	PHP 27-AT5-12RSB
13	20,69	19,45	25	1F	6	8	21	13	27	0,02	PHP 27-AT5-13RSB
14	22,29	21,05	26	1F	6	9	21	14	27	0,03	PHP 27-AT5-14RSB
15	23,88	22,65	28	1F	6	10	21	16	27	0,03	PHP 27-AT5-15RSB
16	25,47	24,20	32	1F	6	11	21	18	27	0,04	PHP 27-AT5-16RSB
17	27,06	25,80	32	1F	6	12	21	19	27	0,04	PHP 27-AT5-17RSB
18	28,65	27,40	32	1F	6	13	21	20	27	0,04	PHP 27-AT5-18RSB
19	30,25	29,00	36	1F	6	14	21	22	27	0,05	PHP 27-AT5-19RSB
20	31,83	30,60	36	1F	6	15	21	23	27	0,05	PHP 27-AT5-20RSB
21	33,42	32,20	38	1F	6	15	21	24	27	0,05	PHP 27-AT5-21RSB
22	35,02	33,85	38	1F	6	15	21	24	27	0,05	PHP 27-AT5-22RSB
23	36,61	35,40	42	1F	6	17	21	25	27	0,07	PHP 27-AT5-23RSB
24	38,21	37,00	44	1F	6	17	21	26	27	0,08	PHP 27-AT5-24RSB
25	39,80	38,60	44	1F	6	17	21	26	27	0,08	PHP 27-AT5-25RSB
26	41,38	40,20	44	1F	6	17	21	26	27	0,09	PHP 27-AT5-26RSB
27	42,98	41,80	48	1F	8	19	21	30	27	0,09	PHP 27-AT5-27RSB
28	44,56	43,35	48	1F	8	20	21	32	27	0,09	PHP 27-AT5-28RSB
30	47,76	46,55	51	1F	8	22	21	34	27	0,11	PHP 27-AT5-30RSB
32	50,94	49,70	54	1F	8	24	21	38	27	0,12	PHP 27-AT5-32RSB
36	57,31	56,05	63	1F	8	24	21	38	27	0,16	PHP 27-AT5-36RSB
38	60,48	59,25	66	1F	8	26	21	40	27	0,18	PHP 27-AT5-38RSB
40	63,66	62,45	66	1F	8	26	21	40	27	0,19	PHP 27-AT5-40RSB
42	66,74	65,60	71	1F	8	26	21	40	27	0,21	PHP 27-AT5-42RSB
44	70,05	68,80	-	1	8	29	21	45	27	0,23	PHP 27-AT5-44RSB
45	71,62	70,35	-	1	8	29	21	45	27	0,26	PHP 27-AT5-45RSB
48	76,42	75,15	-	1	8	32	21	50	27	0,28	PHP 27-AT5-48RSB
60	95,52	94,25	-	1	8	37	21	65	27	0,43	PHP 27-AT5-60RSB
72	114,62	113,15	-	1	10	42	21	80	27	0,41	PHP 27-AT5-72RSB



Metric timing pulleys

Type AT

Pilot bore (RSB)

- ▶ Belts
- ▶ Chains
- ▶ Couplings
- ▶ Bushings and Hubs
- ▶ Sprockets
- ▶ Pulleys
- ▶ Smart tools

5 mm Pitch

Type 1

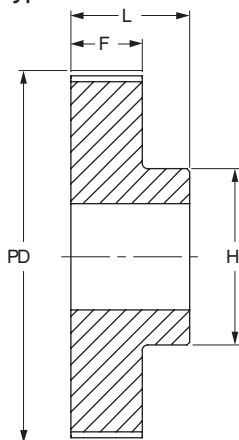

Type 1F

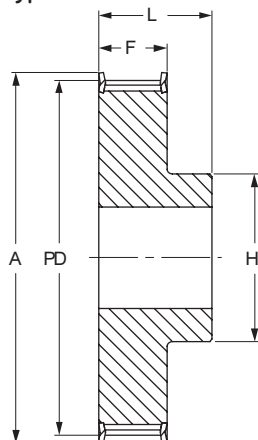

Belt Width 25 mm

No. Teeth	Diameter			Type	Bore		Dimensions			Weight	Designation
	P.D.	O.D.	A		Min	Max	F	H	L		
	mm	mm	mm		mm	mm	mm	mm	mm		
10	15,92	14,65	20	1F	4	5	30	8	36	0,02	PHP 36-AT5-10RSB
12	19,10	17,85	23	1F	6	7	30	12	36	0,03	PHP 36-AT5-12RSB
13	20,69	19,45	25	1F	6	8	30	13	36	0,03	PHP 36-AT5-13RSB
14	22,29	21,05	26	1F	6	9	30	14	36	0,04	PHP 36-AT5-14RSB
15	23,88	22,65	28	1F	6	10	30	16	36	0,04	PHP 36-AT5-15RSB
16	25,47	24,20	32	1F	6	11	30	18	36	0,05	PHP 36-AT5-16RSB
17	27,06	25,80	32	1F	6	12	30	19	36	0,06	PHP 36-AT5-17RSB
18	28,65	27,40	32	1F	6	13	30	20	36	0,06	PHP 36-AT5-18RSB
19	30,25	29,00	36	1F	6	14	30	22	36	0,07	PHP 36-AT5-19RSB
20	31,83	30,60	36	1F	6	15	30	23	36	0,08	PHP 36-AT5-20RSB
21	33,42	32,20	38	1F	6	15	30	24	36	0,08	PHP 36-AT5-21RSB
22	35,02	33,85	38	1F	6	15	30	24	36	0,08	PHP 36-AT5-22RSB
23	36,61	35,40	42	1F	6	16	30	25	36	0,09	PHP 36-AT5-23RSB
24	38,21	37,00	44	1F	8	17	30	26	36	0,11	PHP 36-AT5-24RSB
25	39,80	38,60	44	1F	8	17	30	26	36	0,12	PHP 36-AT5-25RSB
26	41,38	40,20	44	1F	8	17	30	26	36	0,12	PHP 36-AT5-26RSB
27	42,98	41,80	48	1F	8	19	30	30	36	0,13	PHP 36-AT5-27RSB
28	44,56	43,35	48	1F	8	20	30	32	36	0,13	PHP 36-AT5-28RSB
30	47,76	46,55	51	1F	8	22	30	34	36	0,15	PHP 36-AT5-30RSB
32	50,94	49,70	54	1F	8	24	30	38	36	0,18	PHP 36-AT5-32RSB
36	57,31	56,05	63	1F	8	24	30	38	36	0,23	PHP 36-AT5-36RSB
38	60,48	59,25	66	1F	8	26	30	40	36	0,25	PHP 36-AT5-38RSB
40	63,66	62,45	66	1F	8	26	30	40	36	0,28	PHP 36-AT5-40RSB
42	66,74	65,60	71	1F	8	26	30	40	36	0,28	PHP 36-AT5-42RSB
44	70,05	68,80	-	1	8	29	30	45	36	0,32	PHP 36-AT5-44RSB
45	71,62	70,35	-	1	8	30	30	45	36	0,36	PHP 36-AT5-45RSB
48	76,42	75,15	-	1	8	32	30	50	36	0,40	PHP 36-AT5-48RSB
60	95,52	94,25	-	1	8	37	30	65	36	0,61	PHP 36-AT5-60RSB
72	114,62	113,15	-	1	10	42	30	80	36	0,83	PHP 36-AT5-72RSB



Metric timing pulleys



Type AT
Pilot bore (RSB)

5 mm Pitch

Type 1

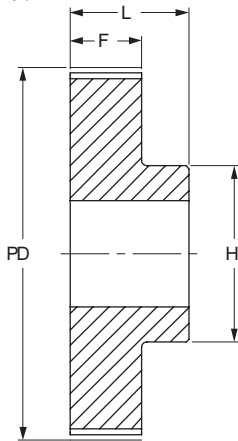

Type 1F

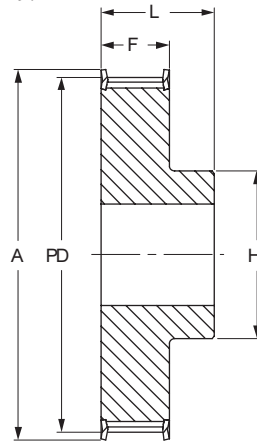

Belt Width 16 mm

No. Teeth	Diameter			Type	Bore		Dimensions			Weight	Designation
	P.D.	O.D.	A		Min	Max	F	H	L		
	mm	mm	mm		mm	mm	mm	mm	mm		
12	38,20	36,35	42	1F	6	18	21	28	31	0,08	PHP 31-AT10-12RSB
14	44,60	42,70	48	1F	8	21	21	32	31	0,10	PHP 31-AT10-14RSB
15	47,75	45,90	51	1F	8	21	21	32	31	0,12	PHP 31-AT10-15RSB
16	50,93	49,05	54	1F	8	23	21	35	31	0,13	PHP 31-AT10-16RSB
17	54,11	52,25	58	1F	8	24	21	38	31	0,15	PHP 31-AT10-17RSB
18	57,29	55,45	60	1F	8	26	21	40	31	0,17	PHP 31-AT10-18RSB
19	60,48	58,65	66	1F	8	28	21	44	31	0,19	PHP 31-AT10-19RSB
20	63,66	61,80	66	1F	8	30	21	46	31	0,21	PHP 31-AT10-20RSB
21	66,85	65,00	71	1F	8	32	21	48	31	0,23	PHP 31-AT10-21RSB
22	70,03	68,15	75	1F	8	34	21	52	31	0,25	PHP 31-AT10-22RSB
23	73,21	71,35	77	1F	8	36	21	55	31	0,27	PHP 31-AT10-23RSB
24	76,39	74,55	83	1F	8	38	21	58	31	0,29	PHP 31-AT10-24RSB
25	79,58	77,75	83	1F	8	39	21	60	31	0,31	PHP 31-AT10-25RSB
26	82,76	80,90	87	1F	8	39	21	60	31	0,36	PHP 31-AT10-26RSB
27	85,95	84,10	91	1F	8	39	21	60	31	0,36	PHP 31-AT10-27RSB
28	89,25	87,25	93	1F	8	39	21	60	31	0,40	PHP 31-AT10-28RSB
30	95,49	93,65	99	1F	8	39	21	60	31	0,44	PHP 31-AT10-30RSB
32	101,86	100,00	106	1F	10	42	21	65	31	0,49	PHP 31-AT10-32RSB
36	114,59	112,75	119	1F	10	45	21	70	31	0,63	PHP 31-AT10-36RSB
38	120,96	119,10	125	1F	10	48	21	75	31	0,70	PHP 31-AT10-38RSB
40	127,32	125,45	131	1F	10	52	21	80	31	0,77	PHP 31-AT10-40RSB
42	133,69	131,85	-	1	10	57	21	80	31	0,88	PHP 31-AT10-42RSB
44	140,05	138,20	-	1	10	57	21	88	31	0,99	PHP 31-AT10-44RSB
45	143,24	141,40	-	1	16	59	21	90	31	1,01	PHP 31-AT10-45RSB
48	152,78	150,95	-	1	16	62	21	95	31	1,09	PHP 31-AT10-48RSB
60	190,98	189,15	-	1	16	72	21	110	31	1,71	PHP 31-AT10-60RSB



Metric timing pulleys

Type AT

Pilot bore (RSB)

- ▶ Belts
- ▶ Chains
- ▶ Couplings
- ▶ Bushings and Hubs
- ▶ Sprockets
- ▶ Pulleys
- ▶ Smart tools

10 mm Pitch

Type 1

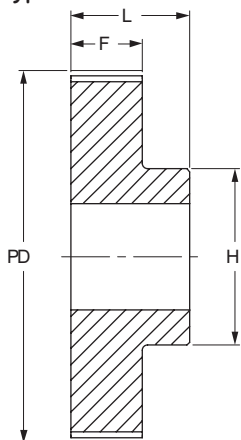

Type 1F

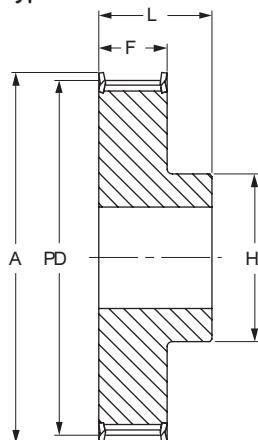

Belt Width 25 mm

No. Teeth	Diameter			Type	Bore		Dimensions			Weight	Designation
	P.D.	O.D.	A		Min	Max	F	H	L		
	mm	mm	mm		mm	mm	mm	mm	mm		
12	38,20	36,40	42	1F	6	18	30	28	40	0,10	PHP 40-AT10-12RSB
14	44,60	42,70	48	1F	8	21	30	32	40	0,13	PHP 40-AT10-14RSB
15	47,80	45,90	51	1F	8	21	30	32	40	0,15	PHP 40-AT10-15RSB
16	50,90	49,10	54	1F	8	23	30	35	40	0,18	PHP 40-AT10-16RSB
17	54,10	52,20	58	1F	8	24	30	37	40	0,20	PHP 40-AT10-17RSB
18	57,30	55,50	60	1F	8	26	30	40	40	0,22	PHP 40-AT10-18RSB
19	60,50	58,60	66	1F	8	28	30	44	40	0,25	PHP 40-AT10-19RSB
20	63,70	61,80	66	1F	8	30	30	46	40	0,28	PHP 40-AT10-20RSB
21	66,80	65,00	71	1F	8	32	30	49	40	0,31	PHP 40-AT10-21RSB
22	70,00	68,20	75	1F	8	34	30	52	40	0,34	PHP 40-AT10-22RSB
23	73,20	71,30	77	1F	8	36	30	55	40	0,36	PHP 40-AT10-23RSB
24	76,40	74,50	83	1F	8	38	30	58	40	0,39	PHP 40-AT10-24RSB
25	79,60	77,80	83	1F	8	39	30	60	40	0,42	PHP 40-AT10-25RSB
26	82,80	80,90	87	1F	8	39	30	60	40	0,48	PHP 40-AT10-26RSB
27	86,00	84,10	91	1F	8	39	30	60	40	0,54	PHP 40-AT10-27RSB
28	89,20	87,20	93	1F	8	39	30	60	40	0,54	PHP 40-AT10-28RSB
30	95,50	93,70	99	1F	8	39	30	60	40	0,64	PHP 40-AT10-30RSB
32	101,90	100,00	106	1F	10	42	30	65	40	0,69	PHP 40-AT10-32RSB
36	114,60	112,80	119	1F	10	45	30	70	40	0,87	PHP 40-AT10-36RSB
38	121,00	119,10	125	1F	10	48	30	75	40	0,97	PHP 40-AT10-38RSB
40	127,30	125,50	131	1F	10	52	30	80	40	1,07	PHP 40-AT10-40RSB
42	133,70	131,80	-	1	10	57	30	80	40	1,21	PHP 40-AT10-42RSB
44	140,10	138,20	-	1	10	57	30	88	40	1,35	PHP 40-AT10-44RSB
45	143,20	141,40	-	1	16	59	30	90	40	1,43	PHP 40-AT10-45RSB
48	152,80	150,90	-	1	16	62	30	95	40	1,52	PHP 40-AT10-48RSB
60	191,00	189,20	-	1	16	72	30	110	40	2,34	PHP 40-AT10-60RSB



Metric timing pulleys



Type AT
Pilot bore (RSB)

10 mm Pitch

Type 1

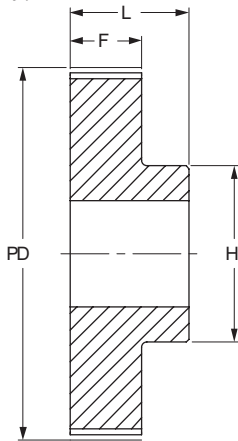

Type 1F

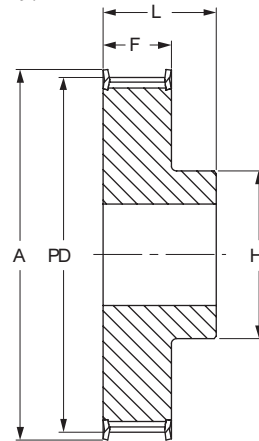

Belt Width 32 mm

No. Teeth	Diameter			Type	Bore		Dimensions			Weight kg	Designation
	P.D.	O.D.	A		Min	Max	F	H	L		
	mm	mm	mm		mm	mm	mm	mm	mm		
18	57,29	55,45	60	1F	8	26	37	40	47	0,25	PHP 47-AT10-18RSB
19	60,48	58,65	66	1F	8	28	37	44	47	0,29	PHP 47-AT10-19RSB
20	63,66	61,80	66	1F	8	30	37	46	47	0,32	PHP 47-AT10-20RSB
21	66,85	65,00	71	1F	8	32	37	49	47	0,36	PHP 47-AT10-21RSB
22	70,03	68,15	75	1F	8	34	37	52	47	0,39	PHP 47-AT10-22RSB
23	73,21	71,35	77	1F	8	36	37	55	47	0,43	PHP 47-AT10-23RSB
24	76,39	74,55	83	1F	8	38	37	58	47	0,48	PHP 47-AT10-24RSB
25	79,58	77,75	83	1F	8	39	37	60	47	0,53	PHP 47-AT10-25RSB
26	82,76	80,90	87	1F	8	39	37	60	47	0,56	PHP 47-AT10-26RSB
27	85,95	84,10	91	1F	8	39	37	60	47	0,60	PHP 47-AT10-27RSB
28	89,25	87,25	93	1F	8	39	37	60	47	0,64	PHP 47-AT10-28RSB
30	95,49	93,65	99	1F	8	39	37	60	47	0,74	PHP 47-AT10-30RSB
32	101,86	100,00	106	1F	10	42	37	65	47	0,84	PHP 47-AT10-32RSB
35	111,41	109,55	115	1F	10	45	37	70	47	0,96	PHP 47-AT10-35RSB
36	114,59	112,75	119	1F	10	45	37	70	47	1,08	PHP 47-AT10-36RSB
38	120,96	119,10	125	1F	10	48	37	75	47	1,20	PHP 47-AT10-38RSB
40	127,32	125,45	131	1F	10	52	37	80	47	1,32	PHP 47-AT10-40RSB
42	133,69	131,85	-	1	10	57	37	80	47	1,46	PHP 47-AT10-42RSB
44	140,20	138,20	-	1	10	57	37	88	47	1,61	PHP 47-AT10-44RSB
45	143,24	141,40	-	1	10	59	37	90	47	1,77	PHP 47-AT10-45RSB
48	152,78	150,95	-	1	16	62	37	95	47	1,93	PHP 47-AT10-48RSB
54	171,89	170,05	-	1	16	66	37	100	47	2,29	PHP 47-AT10-54RSB
57	181,44	179,60	-	1	16	72	37	110	47	2,64	PHP 47-AT10-57RSB
60	190,98	189,15	-	1	16	72	37	110	47	3,00	PHP 47-AT10-60RSB



Metric timing pulleys

Type AT

Pilot bore (RSB)

- ▶ Belts
- ▶ Chains
- ▶ Couplings
- ▶ Bushings and Hubs
- ▶ Sprockets
- ▶ Pulleys
- ▶ Smart tools

10 mm Pitch

Type 1

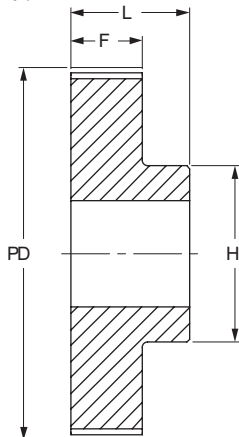

Type 1F

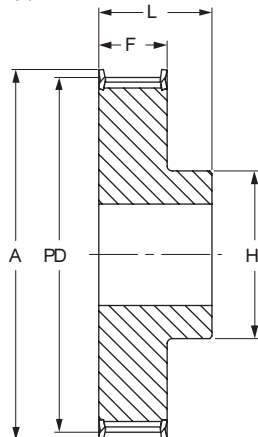

Belt Width 50 mm

No. Teeth	Diameter			Type	Bore		Dimensions			Weight	Designation
	P.D.	O.D.	A		Min	Max	F	H	L		
	mm	mm	mm		mm	mm	mm	mm	mm		
18	57,29	55,45	60	1F	10	26	56	40	66	0,42	PHP 66-AT10-18RSB
19	60,48	58,65	66	1F	10	28	56	44	66	0,47	PHP 66-AT10-19RSB
20	63,66	61,80	66	1F	12	30	56	46	66	0,52	PHP 66-AT10-20RSB
21	66,85	65,00	71	1F	12	32	56	49	66	0,55	PHP 66-AT10-21RSB
22	70,20	68,15	75	1F	12	34	56	52	66	0,57	PHP 66-AT10-22RSB
23	73,21	71,35	77	1F	12	36	56	55	66	0,65	PHP 66-AT10-23RSB
24	76,39	74,55	83	1F	12	38	56	58	66	0,74	PHP 66-AT10-24RSB
25	79,58	77,75	83	1F	12	39	56	60	66	0,77	PHP 66-AT10-25RSB
26	82,76	80,90	87	1F	12	39	56	60	66	0,82	PHP 66-AT10-26RSB
27	85,95	84,10	90	1F	12	39	56	60	66	0,95	PHP 66-AT10-27RSB
28	89,25	87,25	93	1F	12	39	56	60	66	0,96	PHP 66-AT10-28RSB
30	95,49	93,65	99	1F	12	39	56	60	66	1,17	PHP 66-AT10-30RSB
32	101,86	100,00	106	1F	12	42	56	65	66	1,30	PHP 66-AT10-32RSB
35	111,41	109,55	115	1F	16	45	56	70	66	1,47	PHP 66-AT10-35RSB
36	114,59	112,75	119	1F	16	45	56	70	66	1,64	PHP 66-AT10-36RSB
38	120,96	119,10	125	1F	16	48	56	75	66	1,82	PHP 66-AT10-38RSB
40	127,32	125,45	131	1F	16	52	56	80	66	2,00	PHP 66-AT10-40RSB
42	133,69	131,85	-	1	16	57	56	80	66	2,18	PHP 66-AT10-42RSB
44	140,20	138,20	-	1	16	57	56	88	66	2,36	PHP 66-AT10-44RSB
45	143,24	141,40	-	1	16	59	56	90	66	2,59	PHP 66-AT10-45RSB
48	152,78	150,95	-	1	16	62	56	95	66	2,83	PHP 66-AT10-48RSB
54	171,89	170,05	-	1	16	66	56	100	66	3,34	PHP 66-AT10-54RSB
57	181,44	179,60	-	1	16	72	56	110	66	3,85	PHP 66-AT10-57RSB
60	190,98	189,15	-	1	16	72	56	110	66	4,37	PHP 66-AT10-60RSB



Classical V-belt pulleys

A and B section QD bushed



1 Groove

Pitch Diameter P.D.		Outside diameter O.D.	Pulley type	Bushing	Bore		E	L	M	Weight lbs	Weight kg	Designation
B Belts	A Belts				min	max						
Inch	Inch	Inch	Inch	Inch	Inch	Inch	Inch	Inch	Inch			
3,4	3,0	3,75	E-1	SH	1/2	1 5/8	7/32	1 5/16	21/32	4,4	2,0	PHP 1-B34-SH
3,6	3,2	3,95	D-1	SH	1/2	1 5/8	19/32	1 5/16	5/32	4,9	2,2	PHP 1-B36-SH
3,8	3,4	4,15	D-1	SH	1/2	1 5/8	19/32	1 5/16	5/32	5,3	2,4	PHP 1-B38-SH
4,0	3,6	4,35	C-1	SH	1/2	1 5/8	11/32	1 5/16	3/32	6,0	2,7	PHP 1-B40-SH
4,2	3,8	4,55	C-1	SH	1/2	1 5/8	11/32	1 5/16	3/32	6,4	2,9	PHP 1-B42-SH
4,4	4,0	4,75	C-1	SH	1/2	1 5/8	11/32	1 5/16	3/32	7,5	3,4	PHP 1-B44-SH
4,6	4,2	4,95	C-1	SDS	1/2	2	11/32	1 5/16	3/32	8,8	4,0	PHP 1-B46-SDS
4,8	4,4	5,15	C-1	SDS	1/2	2	11/32	1 5/16	3/32	9,5	4,3	PHP 1-B48-SDS
5,0	4,6	5,35	C-1	SDS	1/2	2	11/32	1 5/16	3/32	10,4	4,7	PHP 1-B50-SDS
5,2	4,8	5,55	C-1	SDS	1/2	2	11/32	1 5/16	3/32	11,0	5,0	PHP 1-B52-SDS
5,4	5,0	5,75	C-1	SDS	1/2	2	11/32	1 5/16	3/32	11,7	5,3	PHP 1-B54-SDS
5,6	5,2	5,95	C-1	SDS	1/2	2	11/32	1 5/16	3/32	12,3	5,6	PHP 1-B56-SDS
5,8	5,4	6,15	C-2	SDS	1/2	2	11/32	1 5/16	3/32	13,0	5,9	PHP 1-B58-SDS
6,0	5,6	6,35	C-2	SDS	1/2	2	11/32	1 5/16	3/32	13,7	6,2	PHP 1-B60-SDS
6,2	5,8	6,55	C-2	SDS	1/2	2	11/32	1 5/16	3/32	14,3	6,5	PHP 1-B62-SDS
6,4	6,0	6,75	C-2	SDS	1/2	2	11/32	1 5/16	3/32	15,0	6,8	PHP 1-B64-SDS
6,6	6,2	6,95	C-2	SDS	1/2	2	11/32	1 5/16	3/32	15,9	7,2	PHP 1-B66-SDS
6,8	6,4	7,15	C-3	SDS	1/2	2	11/32	1 5/16	3/32	16,5	7,5	PHP 1-B68-SDS
7,0	6,6	7,35	C-3	SDS	1/2	2	11/32	1 5/16	3/32	17,2	7,8	PHP 1-B70-SDS
7,4	7,0	7,75	D-3	SDS	1/2	2	17/32	1 5/16	7/32	19,4	8,8	PHP 1-B74-SDS
8,0	7,6	8,35	D-3	SDS	1/2	2	17/32	1 5/16	7/32	21,2	9,6	PHP 1-B80-SDS
8,6	8,2	8,95	D-3	SDS	1/2	2	17/32	1 5/16	7/32	22,0	10,0	PHP 1-B86-SDS
9,4	9,0	9,75	D-3	SDS	1/2	2	17/32	1 5/16	7/32	23,1	10,5	PHP 1-B94-SDS
11,0	10,6	11,35	D-3	SDS	1/2	2	17/32	1 5/16	7/32	24,3	11,0	PHP 1-B110-SDS
12,4	12,0	12,75	D-3	SDS	1/2	2	17/32	1 5/16	7/32	26,5	12,0	PHP 1-B124-SDS
13,6	13,2	13,95	D-3	SDS	1/2	2	17/32	1 5/16	7/32	30,9	14,0	PHP 1-B136-SDS
15,4	15,0	15,75	C-3	SK	1/2	2 5/8	21/32	1 15/16	7/32	35,3	16,0	PHP 1-B154-SK
16,0	15,6	16,35	C-3	SK	1/2	2 5/8	21/32	1 15/16	7/32	36,6	16,6	PHP 1-B160-SK
18,4	18,0	18,75	C-3	SK	1/2	2 5/8	21/32	1 15/16	7/32	39,7	18,0	PHP 1-B184-SK
20,0	19,6	20,35	C-3	SK	1/2	2 5/8	21/32	1 15/16	7/32	44,1	20,0	PHP 1-B200-SK

F = 7/8" (1-B34-SH - 1-B70-SDS) F = 1" (1-B74-SDS - 1-B200-SK)

Type A

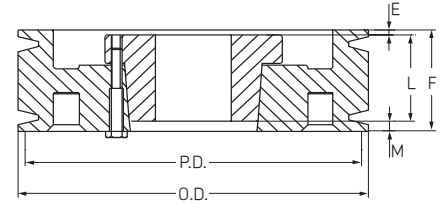

Type C

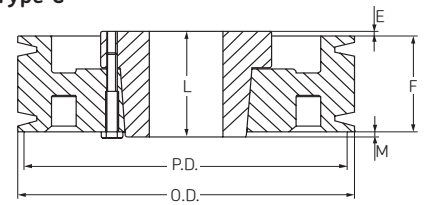

Type D

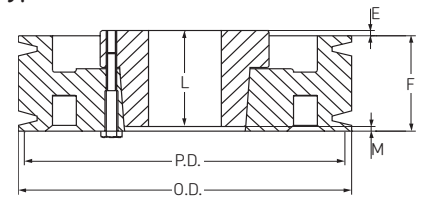

Type E

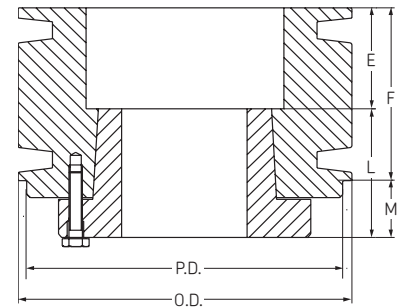

2 Groove

Pitch Diameter P.D.		Outside diameter O.D.	Pulley type	Bushing	Bore		E	L	M	Weight lbs	Weight kg	Designation
B Belts	A Belts				min	max						
Inch	Inch	Inch	Inch	Inch	Inch	Inch	Inch	Inch	Inch			
3,4	3,0	3,75	E-1	SH	1/2	1 5/8	1 3/32	1 5/16	21/32	7,1	3,2	PHP 2-B34-SH
3,6	3,2	3,95	D-1	SH	1/2	1 5/8	15/32	1 5/16	29/32	7,5	3,4	PHP 2-B36-SH
3,8	3,4	4,15	D-1	SH	1/2	1 5/8	15/32	1 5/16	29/32	8,6	3,9	PHP 2-B38-SH
4,0	3,6	4,35	A-1	SH	1/2	1 5/8	1/32	1 5/16	13/32	9,0	4,1	PHP 2-B40-SH
4,2	3,8	4,55	A-1	SH	1/2	1 5/8	1/32	1 5/16	13/32	9,7	4,4	PHP 2-B42-SH
4,4	4,0	4,75	A-1	SH	1/2	1 5/8	1/32	1 5/16	13/32	10,1	4,6	PHP 2-B44-SH
4,6	4,2	4,95	A-1	SDS	1/2	2	1/32	1 5/16	13/32	11,0	5,0	PHP 2-B46-SDS
4,8	4,4	5,15	A-1	SDS	1/2	2	1/32	1 5/16	13/32	11,9	5,4	PHP 2-B48-SDS
5,0	4,6	5,35	A-1	SDS	1/2	2	1/32	1 5/16	13/32	13,2	6,0	PHP 2-B50-SDS
5,2	4,8	5,55	A-1	SDS	1/2	2	1/32	1 5/16	13/32	13,9	6,3	PHP 2-B52-SDS
5,4	5,0	5,75	A-1	SDS	1/2	2	1/32	1 5/16	13/32	14,6	6,6	PHP 2-B54-SDS
5,6	5,2	5,95	A-2	SDS	1/2	2	1/32	1 5/16	13/32	15,2	6,9	PHP 2-B56-SDS
5,8	5,4	6,15	A-2	SDS	1/2	2	1/32	1 5/16	13/32	15,9	7,2	PHP 2-B58-SDS
6,0	5,6	6,35	A-2	SDS	1/2	2	1/32	1 5/16	13/32	16,5	7,5	PHP 2-B60-SDS
6,2	5,8	6,55	A-2	SDS	1/2	2	1/32	1 5/16	13/32	17,2	7,8	PHP 2-B62-SDS
6,4	6,0	6,75	A-2	SDS	1/2	2	1/32	1 5/16	13/32	18,1	8,2	PHP 2-B64-SDS
6,6	6,2	6,95	A-2	SDS	1/2	2	1/32	1 5/16	13/32	19,0	8,6	PHP 2-B66-SDS
6,8	6,4	7,15	A-3	SDS	1/2	2	1/32	1 5/16	13/32	19,8	9,0	PHP 2-B68-SDS
7,0	6,6	7,35	D-1	SK	1/2	2 5/8	11/32	1 15/16	5/32	20,5	9,3	PHP 2-B70-SK
7,4	7,0	7,75	D-3	SK	1/2	2 5/8	11/32	1 15/16	5/32	23,4	10,6	PHP 2-B74-SK
8,0	7,6	8,35	D-3	SK	1/2	2 5/8	11/32	1 15/16	5/32	24,3	11,0	PHP 2-B80-SK
8,6	8,2	8,95	D-3	SK	1/2	2 5/8	11/32	1 15/16	5/32	25,6	11,6	PHP 2-B86-SK
9,4	9,0	9,75	D-3	SK	1/2	2 5/8	11/32	1 15/16	5/32	28,7	13,0	PHP 2-B94-SK
11,0	10,6	11,35	D-3	SK	1/2	2 5/8	11/32	1 15/16	5/32	30,9	14,0	PHP 2-B110-SK
12,4	12,0	12,75	D-3	SK	1/2	2 5/8	11/32	1 15/16	5/32	39,7	18,0	PHP 2-B124-SK
13,6	13,2	13,95	D-3	SK	1/2	2 5/8	11/32	1 15/16	5/32	44,1	20,0	PHP 2-B136-SK
15,4	15,0	15,75	D-3	SK	1/2	2 5/8	11/32	1 15/16	5/32	50,7	23,0	PHP 2-B154-SK
16,0	15,6	16,35	D-3	SK	1/2	2 5/8	11/32	1 15/16	5/32	52,9	24,0	PHP 2-B160-SK
18,4	18,0	18,75	D-3	SK	1/2	2 5/8	11/32	1 15/16	5/32	63,9	29,0	PHP 2-B184-SK
20,0	19,6	20,35	D-3	SF	1/2	2 15/16	15/32	2 1/16	5/32	72,8	33,0	PHP 2-B200-SF
25,0	24,6	25,35	D-3	SF	1/2	2 15/16	15/32	2 1/16	5/32	90,4	41,0	PHP 2-B250-SF
30,0	29,6	30,35	D-3	SF	1/2	2 15/16	15/32	2 1/16	5/32	112,4	51,0	PHP 2-B300-SF
38,0	37,6	38,35	D-3	SF	1/2	2 15/16	15/32	2 1/16	5/32	141,1	64,0	PHP 2-B380-SF

F = 1 3/4"



Classical V-belt pulleys

A and B section QD bushed

- ▶ Belts
- ▶ Chains
- ▶ Couplings
- ▶ Bushings and Hubs
- ▶ Sprockets
- ▶ Pulleys
- ▶ Smart tools

3 Groove

Pitch Diameter P.D.		Outside diameter O.D.	Pulley type	Bushing	Bore		E	L	M	Weight lbs	Weight kg	Designation
B Belts	A Belts				min	max						
Inch	Inch	Inch			Inch	Inch	Inch	Inch	Inch			
3,4	3,0	3,75	E-1	SH	1/2	1 5/8	1 7/32	1 5/16	2 1/32	9,7	4,4	PHP 3-B34-SH
3,6	3,2	3,95	D-1	SH	1/2	1 5/8	1 15/32	1 5/16	1 21/32	10,4	4,7	PHP 3-B36-SH
3,8	3,4	4,15	D-1	SH	1/2	1 5/8	1 15/32	1 5/16	1 21/32	11,7	5,3	PHP 3-B38-SH
4,0	3,6	4,35	D-1	SH	1/2	1 5/8	1 15/32	1 5/16	1 21/32	12,3	5,6	PHP 3-B40-SH
4,2	3,8	4,55	D-1	SH	1/2	1 5/8	1 15/32	1 5/16	1 21/32	13,0	5,9	PHP 3-B42-SH
4,4	4,0	4,75	D-1	SH	1/2	1 5/8	1 15/32	1 5/16	1 21/32	13,9	6,3	PHP 3-B44-SH
4,6	4,2	4,95	A-1	SD	1/2	2	1 13/32	1 13/16	9/32	14,8	6,7	PHP 3-B46-SD
4,8	4,4	5,15	A-1	SD	1/2	2	1 13/32	1 13/16	9/32	15,7	7,1	PHP 3-B48-SD
5,0	4,6	5,35	A-1	SD	1/2	2	1 13/32	1 13/16	9/32	16,3	7,4	PHP 3-B50-SD
5,2	4,8	5,55	A-1	SD	1/2	2	1 13/32	1 13/16	9/32	17,2	7,8	PHP 3-B52-SD
5,4	5,0	5,75	A-1	SD	1/2	2	1 13/32	1 13/16	9/32	18,1	8,2	PHP 3-B54-SD
5,6	5,2	5,95	A-1	SD	1/2	2	1 13/32	1 13/16	9/32	18,7	8,5	PHP 3-B56-SD
5,8	5,4	6,15	A-1	SD	1/2	2	1 13/32	1 13/16	9/32	19,4	8,8	PHP 3-B58-SD
6,0	5,6	6,35	A-1	SD	1/2	2	1 13/32	1 13/16	9/32	20,1	9,1	PHP 3-B60-SD
6,2	5,8	6,55	A-1	SD	1/2	2	1 13/32	1 13/16	9/32	20,7	9,4	PHP 3-B62-SD
6,4	6,0	6,75	A-1	SD	1/2	2	1 13/32	1 13/16	9/32	21,4	9,7	PHP 3-B64-SD
6,6	6,2	6,95	A-1	SD	1/2	2	1 13/32	1 13/16	9/32	22,0	10,0	PHP 3-B66-SD
6,8	6,4	7,15	B-3	SD	1/2	2	1 13/32	1 13/16	9/32	23,1	10,5	PHP 3-B68-SD
7,0	6,6	7,35	D-1	SK	1/2	2 5/8	3/32	1 15/16	2 1/32	24,3	11,0	PHP 3-B70-SK
7,4	7,0	7,75	D-3	SK	1/2	2 5/8	3/32	1 15/16	2 1/32	26,5	12,0	PHP 3-B74-SK
8,0	7,6	8,35	D-3	SK	1/2	2 5/8	3/32	1 15/16	2 1/32	27,6	12,5	PHP 3-B80-SK
8,6	8,2	8,95	D-3	SK	1/2	2 5/8	3/32	1 15/16	2 1/32	28,7	13,0	PHP 3-B86-SK
9,4	9,0	9,75	D-3	SK	1/2	2 5/8	3/32	1 15/16	2 1/32	35,3	16,0	PHP 3-B94-SK
11,0	10,6	11,35	D-3	SK	1/2	2 5/8	3/32	1 15/16	2 1/32	41,9	19,0	PHP 3-B110-SK
12,4	12,0	12,75	D-3	SK	1/2	2 5/8	3/32	1 15/16	2 1/32	52,9	24,0	PHP 3-B124-SK
13,6	13,2	13,95	D-3	SK	1/2	2 5/8	3/32	1 15/16	2 1/32	59,5	27,0	PHP 3-B136-SK
15,4	15,0	15,75	D-3	SK	1/2	2 5/8	3/32	1 15/16	2 1/32	66,1	30,0	PHP 3-B154-SK
16,0	15,6	16,35	D-3	SK	1/2	2 5/8	3/32	1 15/16	2 1/32	72,8	33,0	PHP 3-B160-SK
18,4	18,0	18,75	D-3	SK	1/2	2 5/8	3/32	1 15/16	2 1/32	83,8	38,0	PHP 3-B184-SK
20,0	19,6	20,35	D-3	SF	1/2	2 15/16	7/32	2 1/16	2 1/32	94,8	43,0	PHP 3-B200-SF
25,0	24,6	25,35	D-3	SF	1/2	2 15/16	7/32	2 1/16	2 1/32	119,0	54,0	PHP 3-B250-SF
30,0	29,6	30,35	D-3	SF	1/2	2 15/16	7/32	2 1/16	2 1/32	147,7	67,0	PHP 3-B300-SF
38,0	37,6	38,35	D-3	E	7/8	3 1/2	1 17/32	2 3/4	9/32	198,4	90,0	PHP 3-B380-E

F = 2 1/2" (3-B34-SH - 3-B380-E)

4 Groove

Pitch Diameter P.D.		Outside diameter O.D.	Pulley type	Bushing	Bore		E	L	M	Weight lbs	Weight kg	Designation
B Belts	A Belts				min	max						
Inch	Inch	Inch			Inch	Inch	Inch	Inch	Inch			
3,4	3,0	3,75	E-1	SD	1/2	2	2 15/32	1 13/16	1 1/32	12,1	5,5	PHP 4-B34-SD
3,6	3,2	3,95	E-1	SD	1/2	2	2 15/32	1 13/16	1 1/32	12,8	5,8	PHP 4-B36-SD
3,8	3,4	4,15	E-1	SD	1/2	2	2 15/32	1 13/16	1 1/32	13,7	6,2	PHP 4-B38-SD
4,0	3,6	4,35	E-1	SD	1/2	2	2 2/32	1 13/16	2 1/32	14,6	6,6	PHP 4-B40-SD
4,2	3,8	4,55	E-1	SD	1/2	2	2 2/32	1 13/16	2 1/32	15,2	6,9	PHP 4-B42-SD
4,4	4,0	4,75	E-1	SD	1/2	2	2 2/32	1 13/16	2 1/32	15,9	7,2	PHP 4-B44-SD
4,6	4,2	4,95	A-1	SD	1/2	2	2 1/32	1 13/16	2 5/32	16,8	7,6	PHP 4-B46-SD
4,8	4,4	5,15	A-1	SD	1/2	2	2 1/32	1 13/16	2 5/32	17,6	8,0	PHP 4-B48-SD
5,0	4,6	5,35	A-1	SD	1/2	2	2 1/32	1 13/16	2 5/32	18,5	8,4	PHP 4-B50-SD
5,2	4,8	5,55	A-1	SD	1/2	2	2 1/32	1 13/16	2 5/32	18,7	8,5	PHP 4-B52-SD
5,4	5,0	5,75	A-1	SD	1/2	2	2 1/32	1 13/16	2 5/32	20,3	9,2	PHP 4-B54-SD
5,6	5,2	5,95	A-1	SD	1/2	2	2 1/32	1 13/16	2 5/32	21,2	9,6	PHP 4-B56-SD
5,8	5,4	6,15	A-1	SD	1/2	2	2 1/32	1 13/16	2 5/32	22,0	10,0	PHP 4-B58-SD
6,0	5,6	6,35	A-1	SD	1/2	2	2 1/32	1 13/16	2 5/32	22,9	10,4	PHP 4-B60-SD
6,2	5,8	6,55	A-1	SD	1/2	2	2 1/32	1 13/16	2 5/32	23,8	10,8	PHP 4-B62-SD
6,4	6,0	6,75	A-1	SD	1/2	2	2 1/32	1 13/16	2 5/32	26,5	12,0	PHP 4-B64-SD
6,6	6,2	6,95	A-1	SD	1/2	2	2 1/32	1 13/16	2 5/32	27,3	12,4	PHP 4-B66-SD
6,8	6,4	7,15	A-3	SD	1/2	2	2 1/32	1 13/16	2 5/32	28,7	13,0	PHP 4-B68-SD
7,0	6,6	7,35	A-1	SK	1/2	2 5/8	7/32	1 15/16	1 2/32	29,8	13,5	PHP 4-B70-SK
7,4	7,0	7,75	A-3	SK	1/2	2 5/8	7/32	1 15/16	1 2/32	30,9	14,0	PHP 4-B74-SK
8,0	7,6	8,35	A-3	SK	1/2	2 5/8	7/32	1 15/16	1 2/32	34,2	15,5	PHP 4-B80-SK
8,6	8,2	8,95	A-3	SK	1/2	2 5/8	7/32	1 15/16	1 2/32	37,5	17,0	PHP 4-B86-SK
9,4	9,0	9,75	A-3	SK	1/2	2 5/8	7/32	1 15/16	1 2/32	41,9	19,0	PHP 4-B94-SK
11,0	10,6	11,35	A-3	SK	1/2	2 5/8	7/32	1 15/16	1 2/32	48,5	22,0	PHP 4-B110-SK
12,4	12,0	12,75	A-3	SK	1/2	2 5/8	7/32	1 15/16	1 2/32	63,9	29,0	PHP 4-B124-SK
13,6	13,2	13,95	A-3	SK	1/2	2 5/8	7/32	1 15/16	1 2/32	75,0	34,0	PHP 4-B136-SK
15,4	15,0	15,75	A-3	SF	1/2	2 15/16	5/32	2 1/16	1 1/32	86,0	39,0	PHP 4-B154-SF
16,0	15,6	16,35	A-3	SF	1/2	2 15/16	5/32	2 1/16	1 1/32	92,6	42,0	PHP 4-B160-SF
18,4	18,0	18,75	A-3	SF	1/2	2 15/16	5/32	2 1/16	1 1/32	103,6	47,0	PHP 4-B184-SF
20,0	19,6	20,35	A-3	SF	1/2	2 15/16	5/32	2 1/16	1 1/32	112,4	51,0	PHP 4-B200-SF
25,0	24,6	25,35	D-3	E	7/8	3 1/2	5/32	2 3/4	2 1/32	160,9	73,0	PHP 4-B250-E
30,0	29,6	30,35	D-3	E	7/8	3 1/2	5/32	2 3/4	2 1/32	189,6	86,0	PHP 4-B300-E
38,0	37,6	38,35	D-3	E	7/8	3 1/2	5/32	2 3/4	2 1/32	240,3	109,0	PHP 4-B380-E

F = 3 1/4" (4-B34-SD - 4-B380-E)

Type A

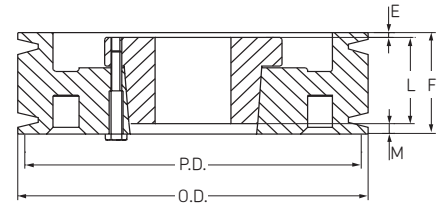

Type B

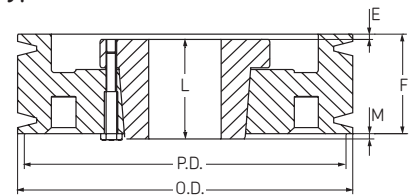

Type D

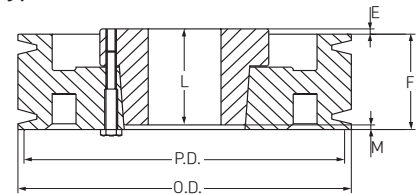

Type E

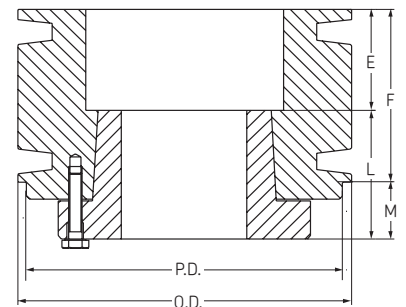



Classical V-belt pulleys

A and B section QD bushed



5 Groove

Pitch Diameter P.D.		Outside diameter O.D.	Pulley type	Bushing	Bore		E	L	M	Weight lbs	Weight kg	Designation
B Belts	A Belts				min	max						
Inch	Inch	Inch			Inch	Inch	Inch	Inch	Inch			
3,4	3,0	3,75	E-1	SD	1/2	2	3 7/32	1 13/16	1 1/32	13,4	6,1	PHP 5-B34-SD
3,6	3,2	3,95	E-1	SD	1/2	2	3 7/32	1 13/16	1 1/32	14,6	6,6	PHP 5-B36-SD
3,8	3,4	4,15	E-1	SD	1/2	2	3 7/32	1 13/16	1 1/32	15,7	7,1	PHP 5-B38-SD
4,0	3,6	4,35	E-1	SD	1/2	2	2 27/32	1 13/16	2 1/32	16,3	7,4	PHP 5-B40-SD
4,2	3,8	4,55	E-1	SD	1/2	2	2 27/32	1 13/16	2 1/32	17,6	8,0	PHP 5-B42-SD
4,4	4,0	4,75	E-1	SD	1/2	2	2 27/32	1 13/16	2 1/32	18,7	8,5	PHP 5-B44-SD
4,6	4,2	4,95	A-1	SD	1/2	2	2 21/32	1 13/16	1 17/32	19,8	9,0	PHP 5-B46-SD
4,8	4,4	5,15	A-1	SD	1/2	2	2 21/32	1 13/16	1 17/32	20,7	9,4	PHP 5-B48-SD
5,0	4,6	5,35	A-1	SD	1/2	2	2 21/32	1 13/16	1 17/32	22,0	10,0	PHP 5-B50-SD
5,2	4,8	5,55	A-1	SD	1/2	2	2 21/32	1 13/16	1 17/32	22,9	10,4	PHP 5-B52-SD
5,4	5,0	5,75	A-1	SK	1/2	2 5/8	1 7/8	1 15/16	1 17/32	23,8	10,8	PHP 5-B54-SK
5,6	5,2	5,95	A-1	SK	1/2	2 5/8	1 7/8	1 15/16	1 17/32	24,9	11,3	PHP 5-B56-SK
5,8	5,4	6,15	A-1	SK	1/2	2 5/8	1 7/8	1 15/16	1 17/32	26,5	12,0	PHP 5-B58-SK
6,0	5,6	6,35	A-1	SK	1/2	2 5/8	1 7/8	1 15/16	1 17/32	30,9	14,0	PHP 5-B60-SK
6,2	5,8	6,55	A-1	SK	1/2	2 5/8	1 7/8	1 15/16	1 17/32	33,1	15,0	PHP 5-B62-SK
6,4	6,0	6,75	A-1	SK	1/2	2 5/8	1 7/8	1 15/16	1 17/32	35,3	16,0	PHP 5-B64-SK
6,6	6,2	6,95	A-1	SK	1/2	2 5/8	1 7/8	1 15/16	1 17/32	37,5	17,0	PHP 5-B66-SK
6,8	6,4	7,15	A-1	SK	1/2	2 5/8	1 7/8	1 15/16	1 17/32	39,7	18,0	PHP 5-B68-SK
7,0	6,6	7,35	A-1	SF	1/2	2 15/16	1 5/8	2 1/16	1 15/32	41,9	19,0	PHP 5-B70-SF
7,4	7,0	7,75	A-2	SF	1/2	2 15/16	1 5/8	2 1/16	1 15/32	44,1	20,0	PHP 5-B74-SF
8,0	7,6	8,35	A-2	SF	1/2	2 15/16	1 5/8	2 1/16	1 15/32	46,3	21,0	PHP 5-B80-SF
8,6	8,2	8,95	A-2	SF	1/2	2 15/16	1 5/8	2 1/16	1 15/32	48,5	22,0	PHP 5-B86-SF
9,4	9,0	9,75	A-3	SF	1/2	2 15/16	1 5/8	2 1/16	1 15/32	52,9	24,0	PHP 5-B94-SF
11,0	10,6	11,35	A-3	SF	1/2	2 15/16	1 5/8	2 1/16	1 15/32	63,9	29,0	PHP 5-B110-SF
12,4	12,0	12,75	A-3	SF	1/2	2 15/16	1 5/8	2 1/16	1 15/32	75,0	34,0	PHP 5-B124-SF
13,6	13,2	13,95	A-3	SF	1/2	2 15/16	1 5/8	2 1/16	1 15/32	83,8	38,0	PHP 5-B136-SF
15,4	15,0	15,75	A-3	SF	1/2	2 15/16	1 5/8	2 1/16	1 15/32	101,4	46,0	PHP 5-B154-SF
16,0	15,6	16,35	A-3	SF	1/2	2 15/16	1 5/8	2 1/16	1 15/32	108,0	49,0	PHP 5-B160-SF
18,4	18,0	18,75	A-3	SF	1/2	2 15/16	1 5/8	2 1/16	1 15/32	121,3	55,0	PHP 5-B184-SF
20,0	19,6	20,35	A-3	E	7/8	1 1/2	2 1/2	2 3/4	1 5/32	143,3	65,0	PHP 5-B200-E
25,0	24,6	25,35	A-3	E	7/8	1 1/2	2 1/2	2 3/4	1 5/32	189,6	86,0	PHP 5-B250-E
30,0	29,6	30,35	A-3	E	7/8	1 1/2	2 1/2	2 3/4	1 5/32	224,9	102,0	PHP 5-B300-E
38,0	37,6	38,35	A-3	E	7/8	1 1/2	2 1/2	2 3/4	1 5/32	291,0	132,0	PHP 5-B380-E

F = 4" (5-B34-SD - 5-B380-SE)

6 Groove

Pitch Diameter P.D.		Outside diameter O.D.	Pulley type	Bushing	Bore		E	L	M	Weight lbs	Weight kg	Designation
B Belts	A Belts				min	max						
Inch	Inch	Inch			Inch	Inch	Inch	Inch	Inch			
3,4	3,0	3,75	E-1	SD	1/2	2	3 31/32	1 13/16	1 1/32	14,8	6,7	PHP 6-B34-SD
3,6	3,2	3,95	E-1	SD	1/2	2	3 31/32	1 13/16	1 1/32	16,3	7,4	PHP 6-B36-SD
3,8	3,4	4,15	E-1	SD	1/2	2	3 31/32	1 13/16	1 1/32	17,6	8,0	PHP 6-B38-SD
4,0	3,6	4,35	E-1	SD	1/2	2	3 19/32	1 13/16	2 1/32	18,5	8,4	PHP 6-B40-SD
4,2	3,8	4,55	E-1	SD	1/2	2	3 19/32	1 13/16	2 1/32	19,8	9,0	PHP 6-B42-SD
4,4	4,0	4,75	E-1	SD	1/2	2	3 19/32	1 13/16	2 1/32	21,4	9,7	PHP 6-B44-SD
4,6	4,2	4,95	A-1	SD	1/2	2	2 21/32	1 13/16	2 9/32	22,3	10,1	PHP 6-B46-SD
4,8	4,4	5,15	A-1	SD	1/2	2	2 21/32	1 13/16	2 9/32	23,4	10,6	PHP 6-B48-SD
5,0	4,6	5,35	A-1	SD	1/2	2	2 21/32	1 13/16	2 9/32	24,3	11,0	PHP 6-B50-SD
5,2	4,8	5,55	A-1	SD	1/2	2	2 21/32	1 13/16	2 9/32	26,5	12,0	PHP 6-B52-SD
5,4	5,0	5,75	A-1	SK	1/2	2 5/8	1 7/8	1 15/16	2 9/32	28,7	13,0	PHP 6-B54-SK
5,6	5,2	5,95	A-1	SK	1/2	2 5/8	1 7/8	1 15/16	2 9/32	30,9	14,0	PHP 6-B56-SK
5,8	5,4	6,15	A-1	SK	1/2	2 5/8	1 7/8	1 15/16	2 9/32	32,2	14,6	PHP 6-B58-SK
6,0	5,6	6,35	A-1	SK	1/2	2 5/8	1 7/8	1 15/16	2 9/32	33,1	15,0	PHP 6-B60-SK
6,2	5,8	6,55	A-1	SK	1/2	2 5/8	1 7/8	1 15/16	2 9/32	35,3	16,0	PHP 6-B62-SK
6,4	6,0	6,75	A-1	SK	1/2	2 5/8	1 7/8	1 15/16	2 9/32	37,5	17,0	PHP 6-B64-SK
6,6	6,2	6,95	A-1	SK	1/2	2 5/8	1 7/8	1 15/16	2 9/32	39,7	18,0	PHP 6-B66-SK
6,8	6,4	7,15	A-1	SK	1/2	2 5/8	1 7/8	1 15/16	2 9/32	41,9	19,0	PHP 6-B68-SK
7,0	6,6	7,35	A-1	SF	1/2	2 15/16	1 5/8	2 1/16	1 27/32	44,1	20,0	PHP 6-B70-SF
7,4	7,0	7,75	A-1	SF	1/2	2 15/16	1 5/8	2 1/16	1 27/32	48,5	22,0	PHP 6-B74-SF
8,0	7,6	8,35	A-2	SF	1/2	2 15/16	1 5/8	2 1/16	1 27/32	52,9	24,0	PHP 6-B80-SF
8,6	8,2	8,95	A-2	SF	1/2	2 15/16	1 5/8	2 1/16	1 27/32	57,3	26,0	PHP 6-B86-SF
9,4	9,0	9,75	A-3	SF	1/2	2 15/16	1 5/8	2 1/16	1 27/32	59,5	27,0	PHP 6-B94-SF
11,0	10,6	11,35	A-3	SF	1/2	2 15/16	1 5/8	2 1/16	1 27/32	70,5	32,0	PHP 6-B110-SF
12,4	12,0	12,75	A-3	SF	1/2	2 15/16	1 5/8	2 1/16	1 27/32	86,0	39,0	PHP 6-B124-SF
13,6	13,2	13,95	A-3	SF	1/2	2 15/16	1 5/8	2 1/16	1 27/32	97,0	44,0	PHP 6-B136-SF
15,4	15,0	15,75	A-3	SF	1/2	2 15/16	1 5/8	2 1/16	1 27/32	110,2	50,0	PHP 6-B154-SF
16,0	15,6	16,35	A-3	SF	1/2	2 15/16	1 5/8	2 1/16	1 27/32	119,0	54,0	PHP 6-B160-SF
18,4	18,0	18,75	A-3	SF	1/2	2 15/16	1 5/8	2 1/16	1 27/32	136,7	62,0	PHP 6-B184-SF
20,0	19,6	20,35	A-3	E	7/8	3 1/2	2 1/2	2 3/4	1 25/32	163,1	74,0	PHP 6-B200-E
25,0	24,6	25,35	A-3	E	7/8	3 1/2	2 1/2	2 3/4	1 25/32	211,6	96,0	PHP 6-B250-E
30,0	29,6	30,35	A-3	E	7/8	3 1/2	2 1/2	2 3/4	1 25/32	262,4	119,0	PHP 6-B300-E
38,0	37,6	38,35	A-3	E	7/8	3 1/2	2 1/2	2 3/4	1 25/32	295,4	134,0	PHP 6-B380-E

F = 4 3/4" (6-B34-SD - 6-B380-E)

Type A

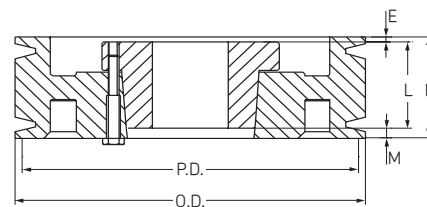

Type E

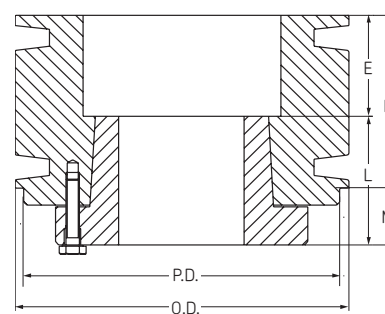



Classical V-belt pulleys

A and B section QD bushed

- ▶ Belts
- ▶ Chains
- ▶ Couplings
- ▶ Bushings and Hubs
- ▶ Sprockets
- ▶ Pulleys
- ▶ Smart tools

8 Groove

Pitch Diameter P.D.		Outside diameter O.D.	Pulley type	Bushing	Bore		E	L	M	Weight lbs	Weight kg	Designation
B Belts	A Belts				min	max						
Inch	Inch	Inch			Inch	Inch	Inch	Inch	Inch			
5,4	5,0	5,75	A-1	SK	1/2	2 5/8	1 1/32	1 15/16	3 9/32	33,1	15,0	PHP 8-B54-SK
5,6	5,2	5,95	A-1	SK	1/2	2 5/8	1 1/32	1 15/16	3 9/32	35,3	16,0	PHP 8-B56-SK
6,0	5,6	6,35	A-1	SF	1/2	2 15/16	31/32	2 1/16	3 7/32	44,1	20,0	PHP 8-B60-SF
6,4	6,0	6,75	A-1	SF	1/2	2 15/16	31/32	2 1/16	3 7/32	50,7	23,0	PHP 8-B64-SF
6,8	6,4	7,15	A-1	SF	1/2	2 15/16	31/32	2 1/16	3 7/32	55,1	25,0	PHP 8-B68-SF
7,4	7,0	7,75	A-1	SF	1/2	2 15/16	31/32	2 1/16	3 7/32	61,7	28,0	PHP 8-B74-SF
8,6	8,2	8,95	A-1	E	7/8	3 1/2	1 7/32	2 3/4	2 9/32	88,2	40,0	PHP 8-B86-E
9,4	9,0	9,75	A-2	E	7/8	3 1/2	1 7/32	2 3/4	2 9/32	94,8	43,0	PHP 8-B94-E
11,0	10,6	11,35	A-3	E	7/8	3 1/2	1 7/32	2 3/4	2 9/32	108,0	49,0	PHP 8-B110-E
12,4	12,0	12,75	A-3	E	7/8	3 1/2	1 7/32	2 3/4	2 9/32	123,5	56,0	PHP 8-B124-E
15,4	15,0	15,75	A-3	E	7/8	3 1/2	1 7/32	2 3/4	2 9/32	152,1	69,0	PHP 8-B154-E
18,4	18,0	18,75	D-3	F	1	4	1 1/32	3 3/4	2 11/32	200,6	91,0	PHP 8-B184-F
20,0	19,6	20,35	D-3	F	1	4	1 1/32	3 3/4	2 11/32	216,1	98,0	PHP 8-B200-F
25,0	24,6	25,35	D-3	F	1	4	1 1/32	3 3/4	2 11/32	266,8	121,0	PHP 8-B250-F
30,0	29,6	30,35	D-3	F	1	4	1 1/32	3 3/4	2 11/32	326,3	148,0	PHP 8-B300-F
38,0	37,6	38,35	D-3	F	1	4	1 1/32	3 3/4	2 11/32	427,7	194,0	PHP 8-B380-F

F = 6 1/4" (8-B54-SK - 8-B380-F)

Type A

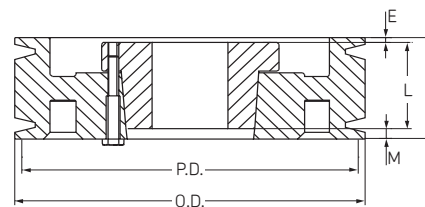

Type D

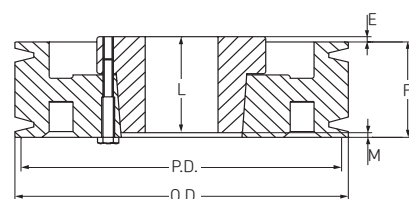

10 Groove

Pitch Diameter P.D.		Outside diameter O.D.	Pulley type	Bushing	Bore		E	L	M	Weight lbs	Weight kg	Designation
B Belts	A Belts				min	max						
Inch	Inch	Inch			Inch	Inch	Inch	Inch	Inch			
5,4	5,0	5,75	A-1	SK	1/2	2 5/8	1 25/32	1 15/16	4 1/32	39,7	18,0	PHP 10-B54-SK
5,6	5,2	5,95	A-1	SK	1/2	2 5/8	1 25/32	1 15/16	4 1/32	44,1	20,0	PHP 10-B56-SK
6,0	5,6	6,35	A-1	SF	1/2	2 15/16	1 22/32	2 1/16	3 31/32	52,9	24,0	PHP 10-B60-SF
6,4	6,0	6,75	A-1	SF	1/2	2 15/16	1 22/32	2 1/16	3 31/32	57,3	26,0	PHP 10-B64-SF
6,8	6,4	7,15	A-1	SF	1/2	2 15/16	1 22/32	2 1/16	3 31/32	61,7	28,0	PHP 10-B68-SF
7,4	7,0	7,75	A-1	SF	1/2	2 15/16	1 22/32	2 1/16	3 31/32	70,5	32,0	PHP 10-B74-SF
8,6	8,2	8,95	A-1	E	7/8	3 1/2	1 31/32	2 3/4	3 1/32	92,6	42,0	PHP 10-B86-E
9,4	9,0	9,75	A-2	E	7/8	3 1/2	1 31/32	2 3/4	3 1/32	105,8	48,0	PHP 10-B94-E
11,0	10,6	11,35	A-3	E	7/8	3 1/2	1 31/32	2 3/4	3 1/32	123,5	56,0	PHP 10-B110-E
12,4	12,0	12,75	A-3	E	7/8	3 1/2	1 31/32	2 3/4	3 1/32	141,1	64,0	PHP 10-B124-E
15,4	15,0	15,75	A-3	F	1	4	5/8	3 3/4	3 9/32	194,0	88,0	PHP 10-B154-F
18,4	18,0	18,75	A-3	F	1	4	5/8	3 3/4	3 9/32	227,1	103,0	PHP 10-B184-F
20,0	19,6	20,35	A-3	F	1	4	5/8	3 3/4	3 9/32	246,9	112,0	PHP 10-B200-F
25,0	24,6	25,35	A-3	F	1	4	5/8	3 3/4	3 9/32	313,1	142,0	PHP 10-B250-F
30,0	29,6	30,35	A-3	F	1	4	5/8	3 3/4	3 9/32	383,6	174,0	PHP 10-B300-F
38,0	37,6	38,35	A-3	J	1 1/2	4 1/2	1 1/8	4 5/8	3	507,1	230,0	PHP 10-B380-J

F = 7 3/4" (10-B54-SK - 10-B380-J)



Classical V-belt pulleys

C section QD bushed



1 Groove

Pitch Diameter P.D.	Outside diameter O.D.	Pulley type	Bushing	Bore		E	L	M	Weight lbs	Weight kg	Designation
				min	max						
Inch	Inch			Inch	Inch	Inch	Inch	Inch			
7,0	7,4	D-1	SF	1/2	2 15/16	27/32	2 1/16	1/32	22,0	10	PHP 1-C70-SF
7,5	7,9	D-2	SF	1/2	2 15/16	27/32	2 1/16	1/32	26,5	12	PHP 1-C75-SF
8,0	8,4	D-2	SF	1/2	2 15/16	27/32	2 1/16	1/32	28,7	13	PHP 1-C80-SF
8,5	8,9	D-2	SF	1/2	2 15/16	27/32	2 1/16	1/32	30,9	14	PHP 1-C85-SF
9,0	9,4	D-3	SF	1/2	2 15/16	27/32	2 1/16	1/32	33,1	15	PHP 1-C90-SF
9,5	9,9	D-3	SF	1/2	2 15/16	27/32	2 1/16	1/32	35,3	16	PHP 1-C95-SF
10,0	10,4	D-3	SF	1/2	2 15/16	27/32	2 1/16	1/32	37,5	17	PHP 1-C100-SF
10,5	10,9	D-3	SF	1/2	2 15/16	27/32	2 1/16	1/32	39,7	18	PHP 1-C105-SF
11,0	11,4	D-3	SF	1/2	2 15/16	27/32	2 1/16	1/32	41,9	19	PHP 1-C110-SF
12,0	12,4	D-3	SF	1/2	2 15/16	27/32	2 1/16	1/32	44,1	20	PHP 1-C120-SF
13,0	13,4	D-3	SF	1/2	2 15/16	27/32	2 1/16	1/32	48,5	22	PHP 1-C130-SF
14,0	14,4	D-3	SF	1/2	2 15/16	27/32	2 1/16	1/32	52,9	24	PHP 1-C140-SF
16,0	16,4	D-3	SF	1/2	2 15/16	27/32	2 1/16	1/32	57,3	26	PHP 1-C160-SF
18,0	18,4	D-3	SF	1/2	2 15/16	27/32	2 1/16	1/32	66,1	30	PHP 1-C180-SF
20,0	20,4	D-3	SF	1/2	2 15/16	27/32	2 1/16	1/32	77,2	35	PHP 1-C200-SF
24,0	24,4	D-3	SF	1/2	2 15/16	27/32	2 1/16	1/32	90,4	41	PHP 1-C240-SF

F = 1 1/4" (1-C70-SF - 1-C240-SF)

Type C

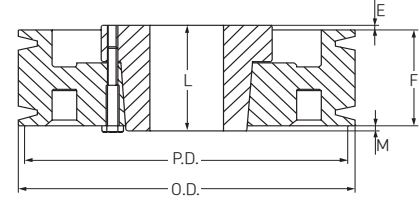

Type D

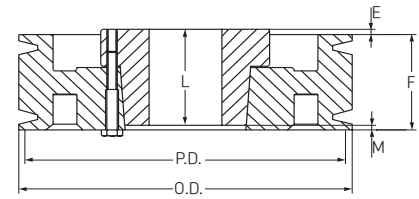

2 Groove

Pitch Diameter P.D.	Outside diameter O.D.	Pulley type	Bushing	Bore		E	L	M	Weight lbs	Weight kg	Designation
				min	max						
Inch	Inch			Inch	Inch	Inch	Inch	Inch			
7,0	7,4	D-1	SF	1/2	2 15/16	3/32	2 1/16	9/32	33,1	15	PHP 2-C70-SF
7,5	7,9	D-1	SF	1/2	2 15/16	3/32	2 1/16	9/32	37,5	17	PHP 2-C75-SF
8,0	8,4	D-1	SF	1/2	2 15/16	3/32	2 1/16	9/32	39,7	18	PHP 2-C80-SF
8,5	8,9	D-2	SF	1/2	2 15/16	3/32	2 1/16	9/32	41,9	19	PHP 2-C85-SF
9,0	9,4	D-2	SF	1/2	2 15/16	3/32	2 1/16	9/32	44,1	20	PHP 2-C90-SF
9,5	9,9	D-2	SF	1/2	2 15/16	3/32	2 1/16	9/32	46,3	21	PHP 2-C95-SF
10,0	10,4	D-3	SF	1/2	2 15/16	3/32	2 1/16	9/32	48,5	22	PHP 2-C100-SF
10,5	10,9	D-3	SF	1/2	2 15/16	3/32	2 1/16	9/32	50,7	23	PHP 2-C105-SF
11,0	11,4	D-3	SF	1/2	2 15/16	3/32	2 1/16	9/32	52,9	24	PHP 2-C110-SF
12,0	12,4	D-3	SF	1/2	2 15/16	11/32	2 1/16	17/32	55,1	25	PHP 2-C120-SF
13,0	13,4	D-3	SF	1/2	2 15/16	11/32	2 1/16	17/32	61,7	28	PHP 2-C130-SF
14,0	14,4	D-3	SF	1/2	2 15/16	11/32	2 1/16	17/32	68,3	31	PHP 2-C140-SF
16,0	16,4	D-3	SF	1/2	2 15/16	11/32	2 1/16	17/32	79,4	36	PHP 2-C160-SF
18,0	18,4	D-3	SF	1/2	2 15/16	11/32	2 1/16	17/32	86,0	39	PHP 2-C180-SF
20,0	20,4	D-3	SF	1/2	2 15/16	11/32	2 1/16	17/32	105,8	48	PHP 2-C200-SF
24,0	24,4	D-3	SF	1/2	2 15/16	11/32	2 1/16	17/32	132,3	60	PHP 2-C240-SF
30,0	30,4	C-3	F	1	4	1 7/32	3 3/4	9/32	187,4	85	PHP 2-C300-F

F = 2 1/4" (2-C70-SF - 2-C300-F)



Classical V-belt pulleys

C section QD bushed

- ▶ Belts
- ▶ Chains
- ▶ Couplings
- ▶ Bushings and Hubs
- ▶ Sprockets
- ▶ Pulleys
- ▶ Smart tools

3 Groove

Pitch Diameter P.D.	Outside diameter O.D.	Pulley type	Bushing	Bore		E	L	M	Weight lbs	Weight kg	Designation	
				min	max							
Inch	Inch			Inch	Inch	Inch	Inch	Inch				
5,0	5,4	A-1	SD	1/2	2	19/32	1 13/16	27/32	22,0	10	PHP 3-C50-SD	
5,5	5,9	A-1	SD	1/2	2	19/32	1 13/16	27/32	26,5	12	PHP 3-C55-SD	
6,0	6,4	D-1	SF	1/2	2	15/16	2 1/16	1 29/32	33,1	15	PHP 3-C60-SF	
7,0	7,4	A-1	SF	1/2	2	15/16	13/32	2 1/16	25/32	39,7	18	PHP 3-C70-SF
7,5	7,9	A-1	SF	1/2	2	15/16	13/32	2 1/16	25/32	44,1	20	PHP 3-C75-SF
8,0	8,4	B-1	E	7/8	3 1/2	17/32	2 3/4	1/2	57,3	26	PHP 3-C80-E	
8,5	8,9	B-1	E	7/8	3 1/2	17/32	2 3/4	1/2	63,9	29	PHP 3-C85-E	
9,0	9,4	A-1	E	7/8	3 1/2	15/32	2 3/4	1/2	70,5	32	PHP 3-C90-E	
9,5	9,9	A-2	E	7/8	3 1/2	15/32	2 3/4	1/2	75,0	34	PHP 3-C95-E	
10,0	10,4	A-2	E	7/8	3 1/2	15/32	2 3/4	1/2	79,4	36	PHP 3-C100-E	
10,5	10,9	A-3	E	7/8	3 1/2	15/32	2 3/4	1/2	83,8	38	PHP 3-C105-E	
11,0	11,4	A-3	E	7/8	3 1/2	15/32	2 3/4	1/2	88,2	40	PHP 3-C110-E	
12,0	12,4	A-3	E	7/8	3 1/2	15/32	2 3/4	1/2	94,8	43	PHP 3-C120-E	
13,0	13,4	A-3	E	7/8	3 1/2	15/32	2 3/4	1/2	99,2	45	PHP 3-C130-E	
14,0	14,4	A-3	E	7/8	3 1/2	15/32	2 3/4	1/2	112,4	51	PHP 3-C140-E	
16,0	16,4	A-3	E	7/8	3 1/2	15/32	2 3/4	1/2	130,1	59	PHP 3-C160-E	
18,0	18,4	A-3	E	7/8	3 1/2	15/32	2 3/4	1/2	143,3	65	PHP 3-C180-E	
20,0	20,4	D-3	E	7/8	3 1/2	7/32	2 3/4	23/32	154,3	70	PHP 3-C200-E	
24,0	24,4	D-3	E	7/8	3 1/2	7/32	2 3/4	23/32	176,4	80	PHP 3-C240-E	
27,0	27,4	D-3	F	1	4	21/32	3 3/4	5/32	231,5	105	PHP 3-C270-F	
30,0	30,4	D-3	F	1	4	21/32	3 3/4	5/32	264,6	120	PHP 3-C300-F	
36,0	36,4	D-3	F	1	4	21/32	3 3/4	5/32	308,6	140	PHP 3-C360-F	
44,0	44,4	D-3	F	1	4	21/32	3 3/4	5/32	374,8	170	PHP 3-C440-F	
50,0	50,4	D-3	F	1	4	21/32	3 3/4	5/32	418,9	190	PHP 3-C500-F	

F = 3 1/4" (3-C50-SD - 3-C500-F)

4 Groove

Pitch Diameter P.D.	Outside diameter O.D.	Pulley type	Bushing	Bore		E	L	M	Weight lbs	Weight kg	Designation
				min	max						
Inch	Inch			Inch	Inch	Inch	Inch	Inch			
5,0	5,4	A-1	SD	1/2	2	27/32	1 13/16	1 19/32	26,5	12	PHP 4-C50-SD
5,5	5,9	A-1	SD	1/2	2	27/32	1 13/16	1 19/32	30,9	14	PHP 4-C55-SD
6,0	6,4	A-1	SF	1/2	2	15/16	2 1/16	1 17/32	37,5	17	PHP 4-C60-SF
7,0	7,4	A-1	SF	1/2	2	15/16	2 1/16	1 17/32	46,3	21	PHP 4-C70-SF
7,5	7,9	A-1	SF	1/2	2	15/16	2 1/16	1 17/32	55,1	25	PHP 4-C75-SF
8,0	8,4	A-1	E	7/8	3 1/2	25/32	2 3/4	23/32	66,1	30	PHP 4-C80-E
8,5	8,9	A-1	E	7/8	3 1/2	25/32	2 3/4	23/32	72,8	33	PHP 4-C85-E
9,0	9,4	A-1	E	7/8	3 1/2	25/32	2 3/4	23/32	77,2	35	PHP 4-C90-E
9,5	9,9	A-2	E	7/8	3 1/2	25/32	2 3/4	23/32	83,8	38	PHP 4-C95-E
10,0	10,4	A-2	E	7/8	3 1/2	25/32	2 3/4	23/32	88,2	40	PHP 4-C100-E
10,5	10,9	A-2	E	7/8	3 1/2	25/32	2 3/4	23/32	94,8	43	PHP 4-C105-E
11,0	11,4	A-2	E	7/8	3 1/2	25/32	2 3/4	23/32	101,4	46	PHP 4-C110-E
12,0	12,4	A-3	E	7/8	3 1/2	25/32	2 3/4	23/32	110,2	50	PHP 4-C120-E
13,0	13,4	A-3	E	7/8	3 1/2	25/32	2 3/4	23/32	119,0	54	PHP 4-C130-E
14,0	14,4	A-3	E	7/8	3 1/2	25/32	2 3/4	23/32	130,1	59	PHP 4-C140-E
16,0	16,4	A-3	E	7/8	3 1/2	25/32	2 3/4	23/32	143,3	65	PHP 4-C160-E
18,0	18,4	A-3	E	7/8	3 1/2	25/32	2 3/4	23/32	160,9	73	PHP 4-C180-E
20,0	20,4	A-3	E	7/8	3 1/2	9/32	2 3/4	1 7/32	180,8	82	PHP 4-C200-E
24,0	24,4	D-3	F	1	4	3/32	3 3/4	19/32	231,5	105	PHP 4-C240-F
27,0	27,4	D-3	F	1	4	3/32	3 3/4	19/32	275,6	125	PHP 4-C270-F
30,0	30,4	D-3	F	1	4	3/32	3 3/4	19/32	313,1	142	PHP 4-C300-F
36,0	36,4	D-3	F	1	4	3/32	3 3/4	19/32	379,2	172	PHP 4-C360-F
44,0	44,4	C-3	J	1 1/2	4 1/2	0	4 5/8	3/8	496,0	225	PHP 4-C440-J
50,0	50,4	C-3	J	1 1/2	4 1/2	0	4 5/8	3/8	573,2	260	PHP 4-C500-J

F = 4 1/4" (4-C50-SD - 4-C500-J)

Type A

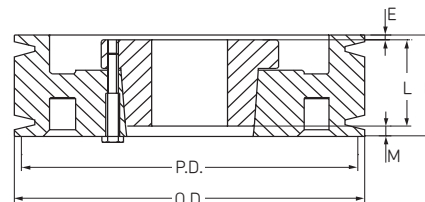

Type B

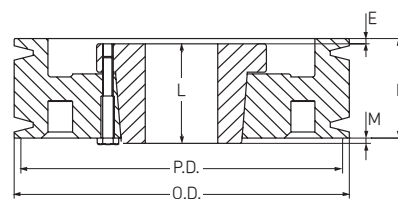

Type C

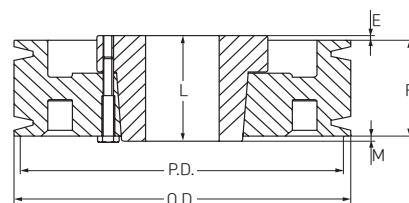

Type D

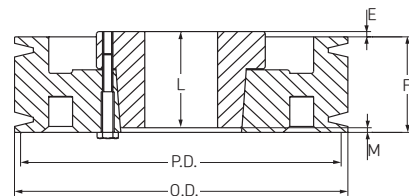



Classical V-belt pulleys

C section QD bushed



5 Groove

Pitch Diameter P.D.	Outside diameter O.D.	Pulley type	Bushing	Bore		E	L	M	Weight lbs	Weight kg	Designation
				min	max						
Inch	Inch			Inch	Inch	Inch	Inch	Inch			
6,0	6,4	A-1	SF	1/2	2 15/16	1 1/32	2 1/16	2 5/32	46,3	21	PHP 5-C60-SF
7,0	7,4	A-1	SF	1/2	2 15/16	1 1/32	2 1/16	2 5/32	57,3	26	PHP 5-C70-SF
7,5	7,9	A-1	SF	1/2	2 15/16	1 1/32	2 1/16	2 5/32	61,7	28	PHP 5-C75-SF
8,0	8,4	A-1	E	7/8	3 1/2	1 5/32	2 3/4	1 11/32	72,8	33	PHP 5-C80-E
8,5	8,9	A-1	E	7/8	3 1/2	1 5/32	2 3/4	1 11/32	81,6	37	PHP 5-C85-E
9,0	9,4	A-1	E	7/8	3 1/2	1 5/32	2 3/4	1 11/32	88,2	40	PHP 5-C90-E
9,5	9,9	A-2	E	7/8	3 1/2	1 5/32	2 3/4	1 11/32	92,6	42	PHP 5-C95-E
10,0	10,4	A-2	E	7/8	3 1/2	1 5/32	2 3/4	1 11/32	99,2	45	PHP 5-C100-E
10,5	10,9	A-2	E	7/8	3 1/2	1 5/32	2 3/4	1 11/32	103,6	47	PHP 5-C105-E
11,0	11,4	A-2	E	7/8	3 1/2	1 5/32	2 3/4	1 11/32	110,2	50	PHP 5-C110-E
12,0	12,4	A-2	E	7/8	3 1/2	1 5/32	2 3/4	1 11/32	116,8	53	PHP 5-C120-E
13,0	13,4	A-3	E	7/8	3 1/2	1 5/32	2 3/4	1 11/32	127,9	58	PHP 5-C130-E
14,0	14,4	A-3	E	7/8	3 1/2	1 5/32	2 3/4	1 11/32	141,1	64	PHP 5-C140-E
16,0	16,4	A-3	E	7/8	3 1/2	1 5/32	2 3/4	1 11/32	160,9	73	PHP 5-C160-E
18,0	18,4	A-3	E	7/8	3 1/2	1 5/32	2 3/4	1 11/32	187,4	85	PHP 5-C180-E
20,0	20,4	D-3	F	1	4	3/32	3 3/4	1 19/32	216,1	98	PHP 5-C200-F
24,0	24,4	D-3	F	1	4	3/32	3 3/4	1 19/32	262,4	119	PHP 5-C240-F
27,0	27,4	D-3	F	1	4	3/32	3 3/4	1 19/32	337,3	153	PHP 5-C270-F
30,0	30,4	D-3	F	1	4	3/32	3 3/4	1 19/32	383,6	174	PHP 5-C300-F
36,0	36,4	A-3	J	1 1/2	4 1/2	1/16	4 5/8	9/16	454,2	206	PHP 5-C360-J
44,0	44,4	A-3	J	1 1/2	4 1/2	1/16	4 5/8	9/16	560,0	254	PHP 5-C440-J
50,0	50,4	A-3	J	1 1/2	4 1/2	1/16	4 5/8	9/16	604,1	274	PHP 5-C500-J

F = 5 1/4" (5-C60-SF - 5-C500-J)

Type A

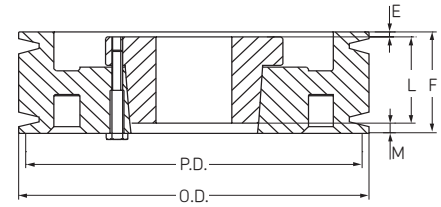

Type B

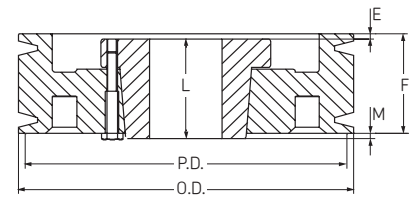

Type D

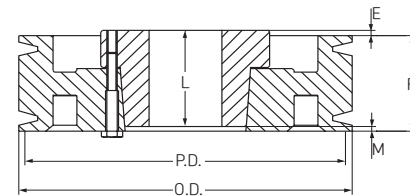

6 Groove

Pitch Diameter P.D.	Outside diameter O.D.	Pulley type	Bushing	Bore		E	L	M	Weight lbs	Weight kg	Designation
				min	max						
Inch	Inch			Inch	Inch	Inch	Inch	Inch			
6,0	6,4	A-1	SF	1/2	2 15/16	1 1/32	2 1/16	3 5/32	44,1	20	PHP 6-C60-SF
7,0	7,4	A-1	SF	1/2	2 15/16	1 1/32	2 1/16	3 5/32	57,3	26	PHP 6-C70-SF
7,5	7,9	A-1	SF	1/2	2 15/16	1 1/32	2 1/16	3 5/32	63,9	29	PHP 6-C75-SF
8,0	8,4	A-1	E	7/8	3 1/2	1 5/32	2 3/4	2 11/32	79,4	36	PHP 6-C80-E
8,5	8,9	A-1	E	7/8	3 1/2	1 5/32	2 3/4	2 11/32	86,0	39	PHP 6-C85-E
9,0	9,4	A-1	F	1	4	1 1/32	3 3/4	1 15/32	112,4	51	PHP 6-C90-F
9,5	9,9	A-1	F	1	4	1 1/32	3 3/4	1 15/32	121,3	55	PHP 6-C95-F
10,0	10,4	A-1	F	1	4	1 1/32	3 3/4	1 15/32	130,1	59	PHP 6-C100-F
10,5	10,9	A-2	F	1	4	1 1/32	3 3/4	1 15/32	136,7	62	PHP 6-C105-F
11,0	11,4	A-2	F	1	4	1 1/32	3 3/4	1 15/32	145,5	66	PHP 6-C110-F
12,0	12,4	A-2	F	1	4	1 1/32	3 3/4	1 15/32	154,3	70	PHP 6-C120-F
13,0	13,4	A-3	F	1	4	1 1/32	3 3/4	1 15/32	163,1	74	PHP 6-C130-F
14,0	14,4	A-3	F	1	4	1 1/32	3 3/4	1 15/32	176,4	80	PHP 6-C140-F
16,0	16,4	A-3	F	1	4	1 1/32	3 3/4	1 15/32	196,2	89	PHP 6-C160-F
18,0	18,4	A-3	F	1	4	1 1/32	3 3/4	1 15/32	224,9	102	PHP 6-C180-F
20,0	20,4	A-3	F	1	4	17/32	3 3/4	1 31/32	246,9	112	PHP 6-C200-F
24,0	24,4	A-3	F	1	4	17/32	3 3/4	1 31/32	288,8	131	PHP 6-C240-F
27,0	27,4	A-3	J	1 1/2	4 1/2	1/16	4 5/8	1 9/16	352,7	160	PHP 6-C270-J
30,0	30,4	A-3	J	1 1/2	4 1/2	1/16	4 5/8	1 9/16	418,9	190	PHP 6-C300-J
36,0	36,4	A-3	J	1 1/2	4 1/2	1/16	4 5/8	1 9/16	511,5	232	PHP 6-C360-J
44,0	44,4	A-3	J	1 1/2	4 1/2	1/16	4 5/8	1 9/16	659,2	299	PHP 6-C440-J
50,0	50,4	B-3	M	2	5 1/2	7/32	6 3/4	23/32	705,5	320	PHP 6-C500-M

F = 6 1/4" (6-C60-SF - 6-C500-M)



Classical V-belt pulleys

C section QD bushed

- ▶ Belts
- ▶ Chains
- ▶ Couplings
- ▶ Bushings and Hubs
- ▶ Sprockets
- ▶ Pulleys
- ▶ Smart tools

8 Groove

Pitch Diameter P.D.	Outside diameter O.D.	Pulley type	Bushing	Bore		E	L	M	Weight lbs	Weight kg	Designation
				min	max						
Inch	Inch			Inch	Inch	Inch	Inch	Inch			
8,0	8,4	A-1	E	7/8	3 1/2	2 1/32	2 3/4	3 15/32	94,8	43	PHP 8-C80-E
8,5	8,9	A-1	E	7/8	3 1/2	3 1/32	2 3/4	3 15/32	105,8	48	PHP 8-C85-E
9,0	9,4	A-1	F	1	4	1 29/32	3 3/4	2 19/32	132,3	60	PHP 8-C90-F
9,5	9,9	A-1	F	1	4	1 29/32	3 3/4	2 19/32	143,3	65	PHP 8-C95-F
10,0	10,4	A-1	F	1	4	1 29/32	3 3/4	2 19/32	152,1	69	PHP 8-C100-F
10,5	10,9	A-2	F	1	4	1 29/32	3 3/4	2 19/32	160,9	73	PHP 8-C105-F
11,0	11,4	A-2	F	1	4	1 29/32	3 3/4	2 19/32	172,0	78	PHP 8-C110-F
12,0	12,4	A-3	F	1	4	1 29/32	3 3/4	2 19/32	183,0	83	PHP 8-C120-F
13,0	13,4	A-3	F	1	4	1 29/32	3 3/4	2 19/32	196,2	89	PHP 8-C130-F
14,0	14,4	A-3	F	1	4	1 29/32	3 3/4	2 19/32	213,8	97	PHP 8-C140-F
16,0	16,4	A-3	F	1	4	1 29/32	3 3/4	2 19/32	249,1	113	PHP 8-C160-F
18,0	18,4	A-3	F	1	4	1 29/32	3 3/4	2 19/32	288,8	131	PHP 8-C180-F
20,0	20,4	A-3	J	1 1/2	4 1/2	1/16	4 5/8	3 9/16	335,1	152	PHP 8-C200-J
24,0	24,4	A-3	J	1 1/2	4 1/2	1/16	4 5/8	3 9/16	407,9	185	PHP 8-C240-J
27,0	27,4	A-3	J	1 1/2	4 1/2	1/16	4 5/8	3 9/16	458,6	208	PHP 8-C270-J
30,0	30,4	A-3	J	1 1/2	4 1/2	1/16	4 5/8	3 9/16	507,1	230	PHP 8-C300-J
36,0	36,4	A-3	M	2	5 1/2	9/32	6 3/4	1 7/32	674,6	306	PHP 8-C360-M
44,0	44,4	A-3	M	2	5 1/2	9/32	6 3/4	1 7/32	881,8	400	PHP 8-C440-M
50,0	50,4	A-3	M	2	5 1/2	9/32	6 3/4	1 7/32	1047,2	475	PHP 8-C500-M

F = 8 1/4" (8-C80-E - 8-C500-M)

Type A

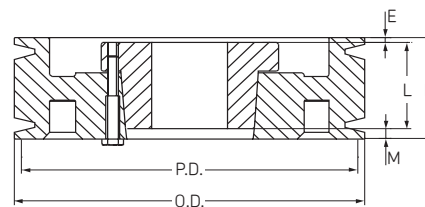



Classical V-belt pulleys

D section QD bushed



3 Groove

Pitch Diameter P.D.	Outside diameter O.D.	Pulley type	Bushing	Bore		E	L	M	Weight lbs	Weight kg	Designation
				min	max						
Inch	Inch			Inch	Inch	Inch	Inch	Inch			
12,0	12,64	A-2	F	1	4	5/32	3 3/4	23/32	154,3	70	PHP 3-D120-F
13,0	13,64	A-2	F	1	4	5/32	3 3/4	23/32	167,6	76	PHP 3-D130-F
13,5	14,14	A-2	F	1	4	5/32	3 3/4	23/32	174,2	79	PHP 3-D135-F
14,0	14,64	A-2	F	1	4	5/32	3 3/4	23/32	180,8	82	PHP 3-D140-F
14,5	15,14	A-3	F	1	4	5/32	3 3/4	23/32	187,4	85	PHP 3-D145-F
15,0	15,64	A-3	F	1	4	5/32	3 3/4	23/32	196,2	89	PHP 3-D150-F
15,5	16,14	A-3	F	1	4	5/32	3 3/4	23/32	202,8	92	PHP 3-D155-F
16,0	16,64	A-3	F	1	4	5/32	3 3/4	23/32	211,6	96	PHP 3-D160-F
18,0	18,64	D-3	J	1 1/2	4 1/2	1/4	4 5/8	1/4	242,5	110	PHP 3-D180-J
20,0	20,64	D-3	J	1 1/2	4 1/2	1/4	4 5/8	1/4	264,6	120	PHP 3-D200-J
22,0	22,64	D-3	J	1 1/2	4 1/2	1/4	4 5/8	1/4	286,6	130	PHP 3-D220-J
27,0	27,64	D-3	J	1 1/2	4 1/2	1/4	4 5/8	1/4	381,4	173	PHP 3-D270-J
33,0	33,64	D-3	J	1 1/2	4 1/2	1/4	4 5/8	1/4	529,1	240	PHP 3-D330-J
40,0	40,64	D-3	J	1 1/2	4 1/2	1/4	4 5/8	1/4	661,4	300	PHP 3-D440-J

F = 4 5/8" (3-D120-F - 3-D440-J)

Type A

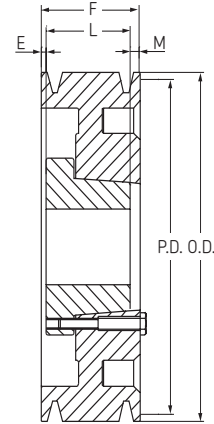

4 Groove

Pitch Diameter P.D.	Outside diameter O.D.	Pulley type	Bushing	Bore		E	L	M	Weight lbs	Weight kg	Designation
				min	max						
Inch	Inch			Inch	Inch	Inch	Inch	Inch			
12,0	12,64	A-2	F	1	4	31/32	3 3/4	1 11/32	183,0	83	PHP 4-D120-F
13,0	13,64	A-2	F	1	4	31/32	3 3/4	1 11/32	189,6	86	PHP 4-D130-F
13,5	14,14	A-2	F	1	4	31/32	3 3/4	1 11/32	196,2	89	PHP 4-D135-F
14,0	14,64	A-2	F	1	4	31/32	3 3/4	1 11/32	202,8	92	PHP 4-D140-F
14,5	15,14	A-3	F	1	4	31/32	3 3/4	1 11/32	209,4	95	PHP 4-D145-F
15,0	15,64	A-3	F	1	4	31/32	3 3/4	1 11/32	218,3	99	PHP 4-D150-F
15,5	16,14	A-3	F	1	4	31/32	3 3/4	1 11/32	224,9	102	PHP 4-D155-F
16,0	16,64	A-3	F	1	4	31/32	3 3/4	1 11/32	233,7	106	PHP 4-D160-F
18,0	18,64	A-3	J	1 1/2	4 1/2	1/8	4 5/8	1 5/16	264,6	120	PHP 4-D180-J
20,0	20,64	A-3	J	1 1/2	4 1/2	1/8	4 5/8	1 5/16	291,0	132	PHP 4-D200-J
22,0	22,64	A-3	J	1 1/2	4 1/2	1/8	4 5/8	1 5/16	341,7	155	PHP 4-D220-J
27,0	27,64	A-3	J	1 1/2	4 1/2	1/8	4 5/8	1 5/16	425,5	193	PHP 4-D270-J
33,0	33,64	B-3	M	2	5 1/2	11/32	6 3/4	1 1/32	617,3	280	PHP 4-D330-M
40,0	40,64	B-3	M	2	5 1/2	11/32	6 3/4	1 1/32	767,2	348	PHP 4-D440-M
48,0	48,64	B-3	M	2	5 1/2	11/32	6 3/4	1 1/32	837,8	380	PHP 4-D480-M
58,0	58,64	B-3	M	2	5 1/2	11/32	6 3/4	1 1/32	925,9	420	PHP 4-D580-M

F = 6 1/16" (4-D120-F - 4-D580-M)

Type B

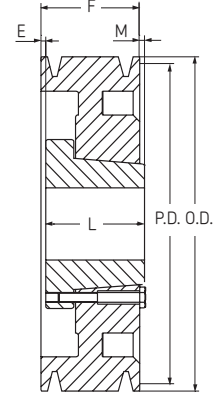

5 Groove

Pitch Diameter P.D.	Outside diameter O.D.	Pulley type	Bushing	Bore		E	L	M	Weight lbs	Weight kg	Designation
				min	max						
Inch	Inch			Inch	Inch	Inch	Inch	Inch			
12,0	12,64	A-2	F	1	4	1 23/32	3 3/4	2 1/32	205,0	93	PHP 5-D120-F
13,0	13,64	A-2	F	1	4	1 23/32	3 3/4	2 1/32	211,6	96	PHP 5-D130-F
13,5	14,14	A-2	F	1	4	1 23/32	3 3/4	2 1/32	224,9	102	PHP 5-D135-F
14,0	14,64	A-2	F	1	4	1 23/32	3 3/4	2 1/32	233,7	106	PHP 5-D140-F
14,5	15,14	A-3	F	1	4	1 23/32	3 3/4	2 1/32	246,9	112	PHP 5-D145-F
15,0	15,64	A-3	F	1	4	1 23/32	3 3/4	2 1/32	264,6	120	PHP 5-D150-F
15,5	16,14	A-3	F	1	4	1 23/32	3 3/4	2 1/32	275,6	125	PHP 5-D155-F
16,0	16,64	A-3	F	1	4	1 23/32	3 3/4	2 1/32	286,6	130	PHP 5-D160-F
18,0	18,64	A-3	J	1 1/2	4 1/2	1 7/8	4 5/8	1	330,7	150	PHP 5-D180-J
20,0	20,64	A-3	J	1 1/2	4 1/2	1 7/8	4 5/8	2 3/4	352,7	160	PHP 5-D200-J
22,0	22,64	A-3	J	1 1/2	4 1/2	1 7/8	4 5/8	2 3/4	418,9	190	PHP 5-D220-J
27,0	27,64	A-3	M	2	5 1/2	11/32	6 3/4	13/32	573,2	260	PHP 5-D270-M
33,0	33,64	A-3	M	2	5 1/2	11/32	6 3/4	13/32	705,5	320	PHP 5-D330-M
40,0	40,64	A-3	M	2	5 1/2	11/32	6 3/4	13/32	859,8	390	PHP 5-D400-M
48,0	48,64	A-3	M	2	5 1/2	11/32	6 3/4	13/32	992,1	450	PHP 5-D480-M
58,0	58,64	A-3	M	2	5 1/2	11/32	6 3/4	13/32	1102,3	500	PHP 5-D580-M

F = 7 1/2" (5-D120-F - 5-D580-M)

Type D

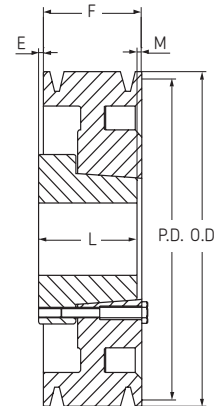



Classical V-belt pulleys

D section QD bushed

- ▶ Belts
- ▶ Chains
- ▶ Couplings
- ▶ Bushings and Hubs
- ▶ Sprockets
- ▶ Pulleys
- ▶ Smart tools

6 Groove

Pitch Diameter P.D.	Outside diameter O.D.	Pulley type	Bushing	Bore		E	L	M	Weight lbs	Weight kg	Designation
				min	max						
Inch	Inch			Inch	Inch	Inch	Inch	Inch			
12,0	12,64	A-1	J	1 1/2	4 1/2	1 7/8	4 5/8	2 7/16	253,5	115	PHP 6-D120-J
13,0	13,64	A-2	J	1 1/2	4 1/2	1 7/8	4 5/8	2 7/16	275,6	125	PHP 6-D130-J
13,5	14,14	A-2	J	1 1/2	4 1/2	1 7/8	4 5/8	2 7/16	297,6	135	PHP 6-D135-J
14,0	14,64	A-2	J	1 1/2	4 1/2	1 7/8	4 5/8	2 7/16	319,7	145	PHP 6-D140-J
14,5	15,14	A-2	J	1 1/2	4 1/2	1 7/8	4 5/8	2 7/16	330,7	150	PHP 6-D145-J
15,0	15,64	A-2	J	1 1/2	4 1/2	1 7/8	4 5/8	2 7/16	352,7	160	PHP 6-D150-J
15,5	16,14	A-3	J	1 1/2	4 1/2	1 7/8	4 5/8	2 7/16	363,8	165	PHP 6-D155-J
16,0	16,64	A-3	J	1 1/2	4 1/2	1 7/8	4 5/8	2 7/16	374,8	170	PHP 6-D160-J
18,0	18,64	A-3	J	1 1/2	4 1/2	1 7/8	4 5/8	2 7/16	396,8	180	PHP 6-D180-J
20,0	20,64	A-3	J	1 1/2	4 1/2	1 7/8	4 5/8	2 7/16	474,0	215	PHP 6-D200-J
22,0	22,64	A-3	M	2	5 1/2	11/32	6 3/4	1 11/16	551,2	250	PHP 6-D220-M
27,0	27,64	A-3	M	2	5 1/2	11/32	6 3/4	1 11/16	661,4	300	PHP 6-D270-M
33,0	33,64	A-3	M	2	5 1/2	11/32	6 3/4	1 11/16	793,7	360	PHP 6-D330-M
40,0	40,64	A-3	M	2	5 1/2	11/32	6 3/4	1 11/16	970,0	440	PHP 6-D400-M
48,0	48,64	A-3	M	2	5 1/2	11/32	6 3/4	1 11/16	1234,6	560	PHP 6-D480-M
58,0	58,64	A-3	N	2 7/16	5 7/8	3/16	8 1/8	5/8	1455,1	660	PHP 6-D580-N

F = 8 15/16" (6-D120-J - 6-D580-N)

Type A

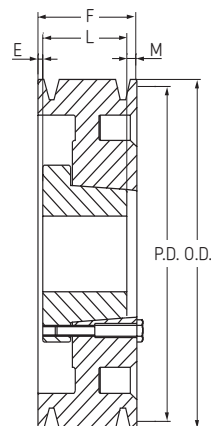

8 Groove

Pitch Diameter P.D.	Outside diameter O.D.	Pulley type	Bushing	Bore		E	L	M	Weight lbs	Weight kg	Designation
				min	max						
Inch	Inch			Inch	Inch	Inch	Inch	Inch			
12,0	12,64	A-1	J	1 1/2	4 1/2	2 1/8	4 5/8	5 1/16	308,6	140	PHP 8-D120-J
13,0	13,64	A-2	J	1 1/2	4 1/2	2 1/8	4 5/8	5 1/16	330,7	150	PHP 8-D130-J
13,5	14,14	A-2	J	1 1/2	4 1/2	2 1/8	4 5/8	5 1/16	352,7	160	PHP 8-D135-J
14,0	14,64	A-2	J	1 1/2	4 1/2	2 1/8	4 5/8	5 1/16	374,8	170	PHP 8-D140-J
14,5	15,14	A-2	J	1 1/2	4 1/2	2 1/8	4 5/8	5 1/16	392,4	178	PHP 8-D145-J
15,0	15,64	A-2	J	1 1/2	4 1/2	2 1/8	4 5/8	5 1/16	401,2	182	PHP 8-D150-J
15,5	16,14	A-2	J	1 1/2	4 1/2	2 1/8	4 5/8	5 1/16	418,9	190	PHP 8-D155-J
16,0	16,64	A-2	J	1 1/2	4 1/2	2 1/8	4 5/8	5 1/16	443,1	201	PHP 8-D160-J
18,0	18,64	A-3	M	2	5 1/2	2 11/32	6 3/4	2 23/32	573,2	260	PHP 8-D180-M
20,0	20,64	A-3	M	2	5 1/2	2 11/32	6 3/4	2 23/32	595,2	270	PHP 8-D200-M
22,0	22,64	A-3	M	2	5 1/2	11/32	6 3/4	4 23/32	661,4	300	PHP 8-D220-M
27,0	27,64	A-3	M	2	5 1/2	11/32	6 3/4	4 23/32	771,6	350	PHP 8-D270-M
33,0	33,64	A-3	M	2	5 1/2	11/32	6 3/4	4 23/32	992,1	450	PHP 8-D330-M
40,0	40,64	A-3	N	2 7/16	5 7/8	3/16	8 1/8	3 1/2	1212,5	550	PHP 8-D400-N
48,0	48,64	A-3	N	2 7/16	5 7/8	3/16	8 1/8	3 1/2	1587,3	720	PHP 8-D480-N
58,0	58,64	A-3	N	2 7/16	5 7/8	3/16	8 1/8	3 1/2	1984,2	900	PHP 8-D580-N

F = 11 13/16" (8-D120-J - 8-D580-N)



Classical V-belt pulleys

D section QD bushed



10 Groove

Pitch Diameter P.D.	Outside diameter O.D.	Pulley type	Bushing	Bore		E	L	M	Weight lbs	Weight kg	Designation
				min	max						
Inch	Inch			Inch	Inch	Inch	Inch	Inch			
12,0	12,64	A-1	M	2	5 1/2	2 11/32	6 3/4	5 19/32	418,9	190	PHP 10-D120-M
13,0	13,64	A-1	M	2	5 1/2	2 11/32	6 3/4	5 19/32	485,0	220	PHP 10-D130-M
13,5	14,14	A-1	M	2	5 1/2	2 11/32	6 3/4	5 19/32	529,1	240	PHP 10-D135-M
14,0	14,64	A-1	M	2	5 1/2	2 11/32	6 3/4	5 19/32	551,2	250	PHP 10-D140-M
14,5	15,14	A-2	M	2	5 1/2	2 11/32	6 3/4	5 19/32	573,2	260	PHP 10-D145-M
15,0	15,64	A-2	M	2	5 1/2	2 11/32	6 3/4	5 19/32	595,2	270	PHP 10-D150-M
15,5	16,14	A-2	M	2	5 1/2	2 11/32	6 3/4	5 19/32	617,3	280	PHP 10-D155-M
16,0	16,64	A-2	M	2	5 1/2	2 11/32	6 3/4	5 19/32	639,3	290	PHP 10-D160-M
18,0	18,64	A-2	M	2	5 1/2	2 11/32	6 3/4	5 19/32	683,4	310	PHP 10-D180-M
20,0	20,64	A-2	M	2	5 1/2	2 11/32	6 3/4	5 19/32	727,5	330	PHP 10-D200-M
22,0	22,64	A-3	M	2	5 1/2	2 11/32	6 3/4	6 19/32	771,6	350	PHP 10-D220-M
27,0	27,64	A-3	M	2	5 1/2	2 11/32	6 3/4	6 19/32	970,0	440	PHP 10-D270-M
33,0	33,64	A-3	N	2 7/16	5 7/8	1 3/16	8 1/8	5 5/8	1102,3	500	PHP 10-D330-N
40,0	40,64	A-3	N	2 7/16	5 7/8	1 3/16	8 1/8	5 5/8	1433,0	650	PHP 10-D400-N
48,0	48,64	A-3	P	2 15/16	7	1/4	9 3/8	5 1/16	2028,3	920	PHP 10-D480-P
58,0	58,64	A-3	P	2 15/16	7	1/4	9 3/8	5 1/16	2425,1	1100	PHP 10-D580-P

F = 14 11/16" (10-D120-M - 10-D580-P)

Type A

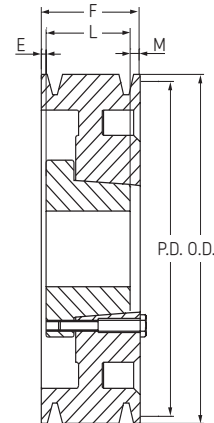

12 Groove

Pitch Diameter P.D.	Outside diameter O.D.	Pulley type	Bushing	Bore		E	L	M	Weight lbs	Weight kg	Designation
				min	max						
Inch	Inch			Inch	Inch	Inch	Inch	Inch			
12,0	12,64	A-1	M	2	5 1/2	3 11/32	6 3/4	7 15/32	485,0	220	PHP 12-D120-M
13,0	13,64	A-1	M	2	5 1/2	3 11/32	6 3/4	7 15/32	551,2	250	PHP 12-D130-M
13,5	14,14	A-1	M	2	5 1/2	3 11/32	6 3/4	7 15/32	595,2	270	PHP 12-D135-M
14,0	14,64	A-1	M	2	5 1/2	3 11/32	6 3/4	7 15/32	617,3	280	PHP 12-D140-M
14,5	15,14	A-1	M	2	5 1/2	3 11/32	6 3/4	7 15/32	661,4	300	PHP 12-D145-M
15,0	15,64	A-2	M	2	5 1/2	3 11/32	6 3/4	7 15/32	672,4	305	PHP 12-D150-M
15,5	16,14	A-1	M	2	5 1/2	3 11/32	6 3/4	7 15/32	683,4	310	PHP 12-D155-M
16,0	16,64	A-2	M	2	5 1/2	3 11/32	6 3/4	7 15/32	705,5	320	PHP 12-D160-M
18,0	18,64	A-2	M	2	5 1/2	3 11/32	6 3/4	7 15/32	749,6	340	PHP 12-D180-M
20,0	20,64	A-2	M	2	5 1/2	3 11/32	6 3/4	7 15/32	793,7	360	PHP 12-D200-M
22,0	22,64	A-3	M	2	5 1/2	2 11/32	6 3/4	8 15/32	881,8	400	PHP 12-D220-M
27,0	27,64	A-3	N	2 7/16	5 7/8	2 3/16	8 1/8	7 1/4	1146,4	520	PHP 12-D270-N
33,0	33,64	A-3	N	2 7/16	5 7/8	2 5/16	8 1/8	7 3/4	1466,1	665	PHP 12-D330-N
40,0	40,64	A-3	P	2 15/16	7	1/4	9 3/8	7 15/16	1918,0	870	PHP 12-D400-P
48,0	48,64	A-3	P	2 15/16	7	1/4	9 3/8	7 15/16	2403,0	1090	PHP 12-D480-P
58,0	58,64	A-3	P	2 15/16	7	1/4	9 3/8	7 15/16	2866,0	1300	PHP 12-D580-P

F = 17 9/16" (12-D120-M - 12-D580-P)



Narrow wedge belt pulleys

3V section QD bushed

- ▶ Belts
- ▶ Chains
- ▶ Couplings
- ▶ Bushings and Hubs
- ▶ Sprockets
- ▶ Pulleys
- ▶ Smart tools

1 Groove

Pitch Diameter P.D.	Outside diameter O.D.	Pulley type	Bushing	Bore		E	L	M	Weight lbs	Weight kg	Designation
				min	max						
Inch	Inch			Inch	Inch	Inch	Inch	Inch			
2,15	2,20	E-1	JA	1/2	1 1/4	5/8	1	15/16	0,9	0,4	PHP 1-3V220-JA
2,30	2,35	E-1	JA	1/2	1 1/4	19/32	1	29/32	0,9	0,4	PHP 1-3V235-JA
2,45	2,50	E-1	JA	1/2	1 1/4	19/32	1	29/32	1,1	0,5	PHP 1-3V250-JA
2,60	2,65	D-1	JA	1/2	1 1/4	3/8	1	1/16	1,3	0,6	PHP 1-3V265-JA
2,75	2,80	D-1	JA	1/2	1 1/4	3/8	1	1/16	1,5	0,7	PHP 1-3V280-JA
2,95	3,00	D-1	JA	1/2	1 1/4	3/8	1	1/16	1,8	0,8	PHP 1-3V300-JA
3,10	3,15	D-1	JA	1/2	1 1/4	3/8	1	1/16	2,0	0,9	PHP 1-3V315-JA
3,30	3,35	D-1	JA	1/2	1 1/4	3/8	1	1/16	2,2	1,0	PHP 1-3V335-JA
3,60	3,65	D-1	SH	1/2	1 5/8	21/32	1	5/16	2,9	1,3	PHP 1-3V365-SH
4,07	4,12	D-1	SH	1/2	1 5/8	21/32	1	5/16	4,0	1,8	PHP 1-3V412-SH
4,45	4,50	D-1	SH	1/2	1 5/8	21/32	1	5/16	4,6	2,1	PHP 1-3V450-SH
4,70	4,75	D-1	SH	1/2	1 5/8	21/32	1	5/16	5,3	2,4	PHP 1-3V475-SH
4,95	5,00	D-1	SH	1/2	1 5/8	21/32	1	5/16	6,0	2,7	PHP 1-3V500-SH
5,25	5,30	D-1	SH	1/2	1 5/8	21/32	1	5/16	6,4	2,9	PHP 1-3V530-SH
5,55	5,60	D-2	SH	1/2	1 5/8	21/32	1	5/16	6,6	3,0	PHP 1-3V560-SH
5,95	6,00	D-2	SH	1/2	1 5/8	21/32	1	5/16	7,1	3,2	PHP 1-3V600-SH
6,45	6,50	D-2	SH	1/2	1 5/8	21/32	1	5/16	9,3	4,2	PHP 1-3V650-SH
6,85	6,90	D-3	SH	1/2	1 5/8	21/32	1	5/16	9,7	4,4	PHP 1-3V690-SH
7,95	8,00	D-3	SDS	1/2	2	21/32	1	5/16	12,8	5,8	PHP 1-3V800-SDS
10,55	10,60	D-3	SDS	1/2	2	21/32	1	5/16	17,4	7,9	PHP 1-3V1060-SDS
13,95	14,00	C-3	SK	1/2	2 5/8	25/32	1	5/16	32,6	14,8	PHP 1-3V1400-SK
18,95	19,00	C-3	SK	1/2	2 5/8	25/32	1	5/16	52,9	24,0	PHP 1-3V1900-SK

F = 11/16" (17,46 mm)

2 Groove

Pitch Diameter P.D.	Outside diameter O.D.	Pulley type	Bushing	Bore		E	L	M	Weight lbs	Weight kg	Designation
				min	max						
Inch	Inch			Inch	Inch	Inch	Inch	Inch			
2,15	2,20	E-1	JA	1/2	1 1/4	11/32	1	15/16	1,3	0,6	PHP 2-3V220-JA
2,30	2,35	E-1	JA	1/2	1 1/4	1	1	29/32	1,3	0,6	PHP 2-3V235-JA
2,45	2,50	E-1	JA	1/2	1 1/4	1	1	29/32	1,5	0,7	PHP 2-3V250-JA
2,60	2,65	D-1	JA	1/2	1 1/4	3/8	1	15/32	1,8	0,8	PHP 2-3V265-JA
2,75	2,80	D-1	JA	1/2	1 1/4	3/8	1	15/32	2,0	0,9	PHP 2-3V280-JA
2,95	3,00	D-1	JA	1/2	1 1/4	3/8	1	15/32	2,6	1,2	PHP 2-3V300-JA
3,10	3,15	D-1	JA	1/2	1 1/4	3/8	1	15/32	2,6	1,2	PHP 2-3V315-JA
3,30	3,35	D-1	SH	1/2	1 5/8	17/32	1	5/16	2,9	1,3	PHP 2-3V335-SH
3,60	3,65	D-1	SH	1/2	1 5/8	17/32	1	5/16	3,3	1,5	PHP 2-3V365-SH
4,07	4,12	D-1	SH	1/2	1 5/8	11/32	1	5/16	4,9	2,2	PHP 2-3V412-SH
4,45	4,50	D-1	SH	1/2	1 5/8	11/32	1	5/16	6,0	2,7	PHP 2-3V450-SH
4,70	4,75	D-1	SH	1/2	1 5/8	11/32	1	5/16	6,8	3,1	PHP 2-3V475-SH
4,95	5,00	D-1	SH	1/2	1 5/8	11/32	1	5/16	7,5	3,4	PHP 2-3V500-SH
5,25	5,30	D-1	SH	1/2	1 5/8	11/32	1	5/16	8,6	3,9	PHP 2-3V530-SH
5,55	5,60	D-2	SH	1/2	1 5/8	11/32	1	5/16	8,8	4,0	PHP 2-3V560-SH
5,95	6,00	D-2	SH	1/2	1 5/8	11/32	1	5/16	9,7	4,4	PHP 2-3V600-SH
6,45	6,50	D-2	SDS	1/2	2	11/32	1	5/16	13,2	6,0	PHP 2-3V650-SDS
6,85	6,90	D-2	SDS	1/2	2	11/32	1	5/16	16,5	7,5	PHP 2-3V690-SDS
7,95	8,00	D-3	SDS	1/2	2	11/32	1	5/16	18,7	8,5	PHP 2-3V800-SDS
10,55	10,60	C-3	SK	1/2	2 5/8	17/32	1	5/16	27,6	12,5	PHP 2-3V1060-SK
13,95	14,00	C-3	SK	1/2	2 5/8	17/32	1	5/16	43,0	19,5	PHP 2-3V1400-SK
18,95	19,00	C-3	SK	1/2	2 5/8	17/32	1	5/16	59,5	27,0	PHP 2-3V1900-SK
24,95	25,00	C-3	SF	1/2	2 15/16	19/32	2	1/16	83,8	38,0	PHP 2-3V2500-SF

F = 1 3/32" (27,78 mm)

Type C-3

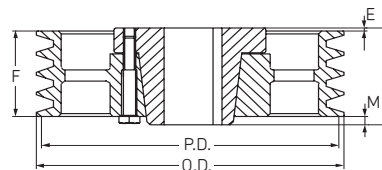

Type D-1

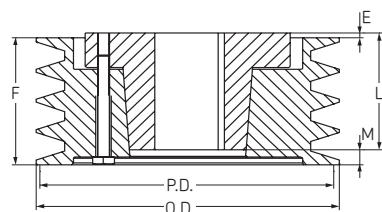

Type D-2

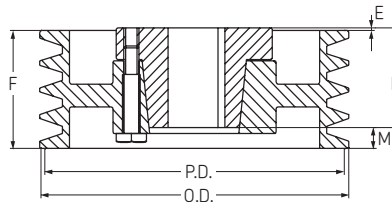

Type D-3

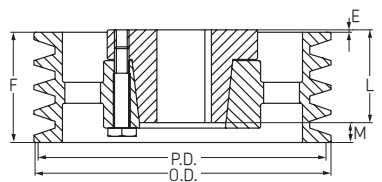

Type E-1

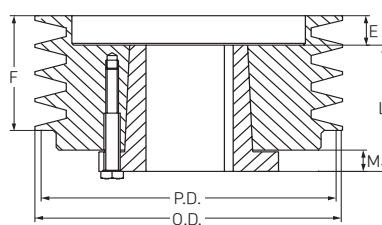



Narrow wedge belt pulleys

3V section QD bushed



3 Groove

Pitch Diameter P.D.	Outside diameter O.D.	Pulley type	Bushing	Bore		E	L	M	Weight lbs	Weight kg	Designation
				min	max						
Inch	Inch			Inch	Inch	Inch	Inch	Inch			
2,45	2,50	E-1	JA	1/2	1 1/4	1 13/32	1	29/32	1,8	0,8	PHP 3-3V250-JA
2,60	2,65	D-1	JA	1/2	1 1/4	3/8	1	7/8	2,2	1,0	PHP 3-3V265-JA
2,75	2,80	D-1	JA	1/2	1 1/4	3/8	1	7/8	3,1	1,4	PHP 3-3V280-JA
2,95	3,00	E-1	SH	1/2	1 5/8	1 5/32	1 5/16	31/32	3,7	1,7	PHP 3-3V300-SH
3,10	3,15	E-1	SH	1/2	1 5/8	1 5/32	1 5/16	31/32	4,0	1,8	PHP 3-3V315-SH
3,30	3,35	D-1	SH	1/2	1 5/8	17/32	1 5/16	23/32	4,2	1,9	PHP 3-3V335-SH
3,60	3,65	D-1	SH	1/2	1 5/8	17/32	1 5/16	23/32	5,1	2,3	PHP 3-3V365-SH
4,07	4,12	A-1	SH	1/2	1 5/8	17/32	1 5/16	5/32	6,2	2,8	PHP 3-3V412-SH
4,45	4,50	A-1	SDS	1/2	2	1/32	1 5/16	5/32	7,7	3,5	PHP 3-3V450-SDS
4,70	4,75	A-1	SDS	1/2	2	1/32	1 5/16	5/32	8,8	4,0	PHP 3-3V475-SDS
4,95	5,00	A-1	SDS	1/2	2	1/32	1 5/16	5/32	9,9	4,5	PHP 3-3V500-SDS
5,25	5,30	A-1	SDS	1/2	2	1/32	1 5/16	5/32	11,5	5,2	PHP 3-3V530-SDS
5,55	5,60	A-1	SDS	1/2	2	1/32	1 5/16	5/32	13,2	6,0	PHP 3-3V560-SDS
5,95	6,00	A-2	SDS	1/2	2	1/32	1 5/16	5/32	15,4	7,0	PHP 3-3V600-SDS
6,45	6,50	A-2	SDS	1/2	2	1/32	1 5/16	5/32	17,9	8,1	PHP 3-3V650-SDS
6,85	6,90	A-2	SDS	1/2	2	1/32	1 5/16	5/32	19,6	8,9	PHP 3-3V690-SDS
7,95	8,00	D-2	SK	1/2	2 5/8	17/32	1 5/16	3/32	24,9	11,3	PHP 3-3V800-SK
10,55	10,60	D-3	SK	1/2	2 5/8	17/32	1 5/16	3/32	30,9	14,0	PHP 3-3V1060-SK
13,95	14,00	D-3	SK	1/2	2 5/8	17/32	1 5/16	3/32	47,6	21,6	PHP 3-3V1400-SK
15,95	16,00	D-3	SK	1/2	2 5/8	17/32	1 5/16	3/32	55,6	25,2	PHP 3-3V1600-SK
18,95	19,00	D-3	SF	1/2	2 15/16	19/32	2 1/16	1/32	70,8	32,1	PHP 3-3V1900-SF
24,95	25,00	D-3	SF	1/2	2 15/16	19/32	2 1/16	1/32	110,2	50,0	PHP 3-3V2500-SF
33,45	33,50	D-3	SF	7/8	3 1/2	19/32	2 1/16	1/32	172,0	78,0	PHP 3-3V3350-SF

F = 1 1/2" (38,10 mm)

4 Groove

Pitch Diameter P.D.	Outside diameter O.D.	Pulley type	Bushing	Bore		E	L	M	Weight lbs	Weight kg	Designation
				min	max						
Inch	Inch			Inch	Inch	Inch	Inch	Inch			
2,60	2,65	D-1	JA	1/2	1 1/4	3/8	1	19/32	2,9	1,3	PHP 4-3V265-JA
2,75	2,80	D-1	JA	1/2	1 1/4	3/8	1	19/32	3,7	1,7	PHP 4-3V280-JA
2,95	3,00	E-1	SH	1/2	1 5/8	1/2	1 5/16	29/32	4,4	2,0	PHP 4-3V300-SH
3,10	3,15	E-1	SH	1/2	1 5/8	1/2	1 5/16	29/32	4,9	2,2	PHP 4-3V315-SH
3,30	3,35	D-1	SH	1/2	1 5/8	17/32	1 5/16	1 1/8	5,1	2,3	PHP 4-3V335-SH
3,60	3,65	D-1	SH	1/2	1 5/8	17/32	1 5/16	1 1/8	6,2	2,8	PHP 4-3V365-SH
4,07	4,12	A-1	SH	1/2	1 5/8	5/32	1 5/16	7/16	7,5	3,4	PHP 4-3V412-SH
4,45	4,50	A-1	SDS	1/2	2	5/32	1 5/16	7/16	8,8	4,0	PHP 4-3V450-SDS
4,70	4,75	A-1	SDS	1/2	2	5/32	1 5/16	7/16	10,1	4,6	PHP 4-3V475-SDS
4,95	5,00	A-1	SDS	1/2	2	5/32	1 5/16	7/16	11,5	5,2	PHP 4-3V500-SDS
5,25	5,30	A-1	SDS	1/2	2	5/32	1 5/16	7/16	12,8	5,8	PHP 4-3V530-SDS
5,55	5,60	A-1	SDS	1/2	2	5/32	1 5/16	7/16	15,0	6,8	PHP 4-3V560-SDS
5,95	6,00	D-1	SK	1/2	2 5/8	5/32	1 5/16	1/8	18,3	8,3	PHP 4-3V600-SK
6,45	6,50	D-1	SK	1/2	2 5/8	5/32	1 5/16	1/8	22,0	10,0	PHP 4-3V650-SK
6,85	6,90	D-1	SK	1/2	2 5/8	5/32	1 5/16	1/8	26,2	11,9	PHP 4-3V690-SK
7,95	8,00	D-2	SK	1/2	2 5/8	5/32	1 5/16	1/8	28,7	13,0	PHP 4-3V800-SK
10,55	10,60	D-3	SK	1/2	2 5/8	5/32	1 5/16	1/8	36,4	16,5	PHP 4-3V1060-SK
13,95	14,00	D-3	SK	1/2	2 5/8	5/32	1 5/16	1/8	49,6	22,5	PHP 4-3V1400-SK
15,95	16,00	D-3	SK	1/2	2 5/8	5/32	1 5/16	1/8	61,3	27,8	PHP 4-3V1600-SK
18,95	19,00	D-3	SF	1/2	2 15/16	7/32	2 1/16	1/16	77,2	35,0	PHP 4-3V1900-SF
24,95	25,00	D-3	SF	1/2	2 15/16	7/32	2 1/16	1/16	125,7	57,0	PHP 4-3V2500-SF
33,45	33,50	C-3	E	7/8	3 1/2	21/32	2 3/4	3/16	185,2	84,0	PHP 4-3V3350-E

F = 1 29/32" (48,42 mm)

Type A-1

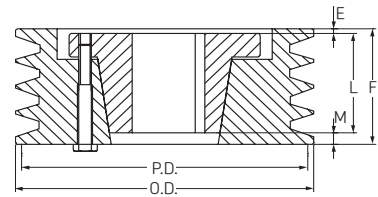

Type A-2

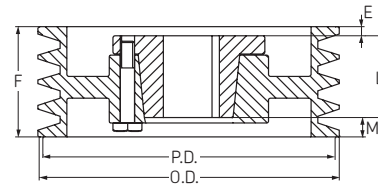

Type C-3

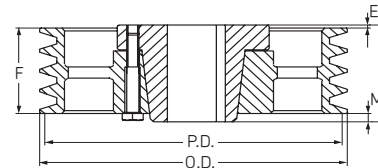

Type D-1

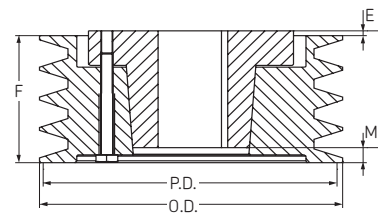

Type D-2

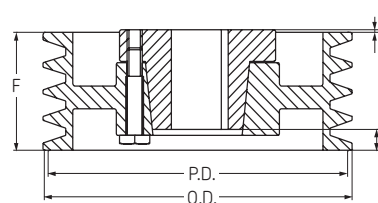

Type D-3

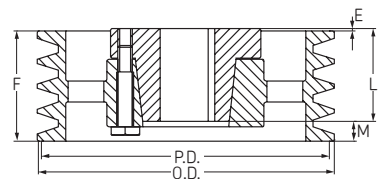

Type E-1

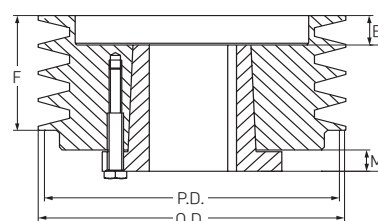



Narrow wedge belt pulleys

3V section QD bushed

- ▶ Belts
- ▶ Chains
- ▶ Couplings
- ▶ Bushings and Hubs
- ▶ Sprockets
- ▶ Pulleys
- ▶ Smart tools

5 Groove

Pitch Diameter P.D.	Outside diameter O.D.	Pulley type	Bushing	Bore		E	L	M	Weight lbs	Weight kg	Designation
				min	max						
Inch	Inch			Inch	Inch	Inch	Inch	Inch			
4,70	4,75	A-1	SDS	1/2	2	5/32	1 15/16	27/32	11,2	5,1	PHP 5-3V475-SDS
4,95	5,00	A-1	SDS	1/2	2	5/32	1 15/16	27/32	12,6	5,7	PHP 5-3V500-SDS
5,25	5,30	A-1	SK	1/2	2	5/8	1 15/16	7/32	14,3	6,5	PHP 5-3V530-SK
5,55	5,60	A-1	SK	1/2	2	5/8	1 15/16	7/32	16,5	7,5	PHP 5-3V560-SK
5,95	6,00	A-1	SK	1/2	2	5/8	1 15/16	7/32	19,6	8,9	PHP 5-3V600-SK
6,45	6,50	A-2	SK	1/2	2	5/8	1 15/16	7/32	23,4	10,6	PHP 5-3V650-SK
6,85	6,90	A-2	SK	1/2	2	5/8	1 15/16	7/32	28,2	12,8	PHP 5-3V690-SK
7,95	8,00	A-2	SK	1/2	2	5/8	1 15/16	7/32	30,4	13,8	PHP 5-3V800-SK
10,55	10,60	A-3	SK	1/2	2	5/8	1 15/16	7/32	37,5	17,0	PHP 5-3V1060-SK
13,95	14,00	A-3	SF	1/2	2	15/16	1/32	2 15/16	57,3	26,0	PHP 5-3V1400-SF
18,95	19,00	A-3	SF	1/2	2	15/16	1/32	2 15/16	90,4	41,0	PHP 5-3V1900-SF
24,95	25,00	D-3	E	7/8	3	1/2	17/32	2 3/4	138,9	63,0	PHP 5-3V2500-E
33,45	33,50	D-3	E	7/8	3	1/2	17/32	2 3/4	209,4	95,0	PHP 5-3V3350-E

F = 2 5/16" (58,74 mm)

6 Groove

Pitch Diameter P.D.	Outside diameter O.D.	Pulley type	Bushing	Bore		E	L	M	Weight lbs	Weight kg	Designation
				min	max						
Inch	Inch			Inch	Inch	Inch	Inch	Inch			
4,70	4,75	D-1	SK	1/2	2	5/8	2 1/32	1 7/16	13,2	6,0	PHP 6-3V475-SK
4,95	5,00	D-1	SK	1/2	2	5/8	2 1/32	1 7/16	13,9	6,3	PHP 6-3V500-SK
5,25	5,30	A-1	SK	1/2	2	5/8	17/32	1 15/16	15,2	6,9	PHP 6-3V530-SK
5,55	5,60	A-1	SK	1/2	2	5/8	17/32	1 15/16	18,7	8,5	PHP 6-3V560-SK
5,95	6,00	A-1	SK	1/2	2	5/8	17/32	1 15/16	21,6	9,8	PHP 6-3V600-SK
6,45	6,50	A-1	SK	1/2	2	5/8	17/32	1 15/16	25,1	11,4	PHP 6-3V650-SK
6,85	6,90	A-1	SK	1/2	2	5/8	17/32	1 15/16	29,5	13,4	PHP 6-3V690-SK
7,95	8,00	A-2	SK	1/2	2	15/16	3/32	1 15/16	33,1	15,0	PHP 6-3V800-SK
10,55	10,60	A-3	SF	1/2	2	15/16	1/32	2 15/16	49,8	22,6	PHP 6-3V1060-SF
13,95	14,00	A-3	SF	1/2	3	1/2	1/32	2 15/16	65,0	29,5	PHP 6-3V1400-SF
18,95	19,00	D-3	E	7/8	3	1/2	5/32	2 3/4	97,0	44,0	PHP 6-3V1900-E
24,95	25,00	D-3	E	7/8	3	1/2	5/32	2 3/4	143,3	65,0	PHP 6-3V2500-E
33,45	33,50	D-3	E	7/8	3	1/2	5/32	2 3/4	222,7	101,0	PHP 6-3V3350-E

F = 2 23/32" (69,06 mm)

Type A-1

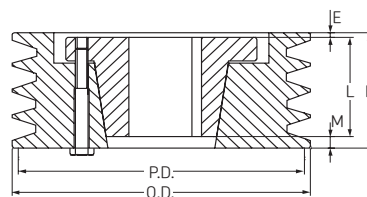

Type A-2

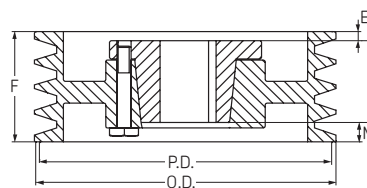

Type A-3

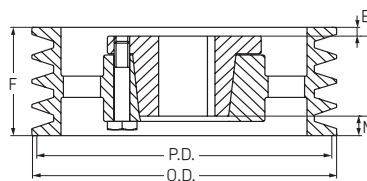

Type D-1

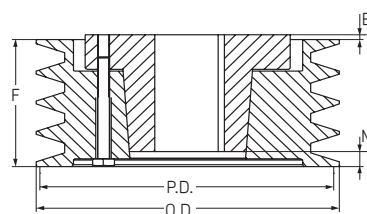

Type D-2

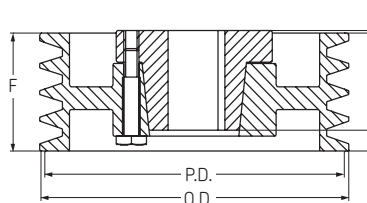

Type D-3

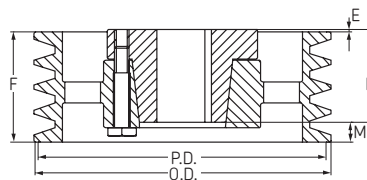



Narrow wedge belt pulleys

3V section QD bushed



8 Groove

Pitch Diameter P.D.	Outside diameter O.D.	Pulley type	Bushing	Bore		E	L	M	Weight lbs	Weight kg	Designation
				min	max						
Inch	Inch			Inch	Inch	Inch	Inch	Inch			
4,70	4,75	D-1	SK	1/2	2 5/8	21/32	1 15/16	2 1/4	15,9	7,2	PHP 8-3V475-SK
4,95	5,00	D-1	SK	1/2	2 5/8	21/32	1 15/16	2 3/4	17,2	7,8	PHP 8-3V500-SK
5,25	5,30	A-1	SK	1/2	2 5/8	17/32	1 15/16	1 1/16	20,5	9,3	PHP 8-3V530-SK
5,55	5,60	A-1	SK	1/2	2 5/8	17/32	1 15/16	1 1/16	23,1	10,5	PHP 8-3V560-SK
5,95	6,00	A-1	SK	1/2	2 5/8	17/32	1 15/16	1 1/16	27,6	12,5	PHP 8-3V600-SK
6,45	6,50	A-1	SK	1/2	2 5/8	17/32	1 15/16	1 1/16	35,3	16,0	PHP 8-3V650-SK
6,85	6,90	A-1	SK	1/2	2 5/8	17/32	1 15/16	1 1/16	39,7	18,0	PHP 8-3V690-SK
7,95	8,00	A-1	SF	1/2	2 15/16	9/32	2 15/16	13/16	46,3	21,0	PHP 8-3V800-SF
10,55	10,60	A-2	SF	1/2	2 15/16	9/32	2 15/16	13/16	56,2	25,5	PHP 8-3V1060-SF
13,95	14,00	A-3	E	7/8	3 1/2	3/32	2 3/4	11/16	84,9	38,5	PHP 8-3V1400-E
18,95	19,00	A-3	E	7/8	3 1/2	3/32	2 3/4	11/16	119,0	54,0	PHP 8-3V1900-E
24,95	25,00	A-3	E	7/8	3 1/2	3/32	2 3/4	11/16	176,4	80,0	PHP 8-3V2500-E
33,45	33,50	D-3	F	1	4	9/32	3 3/4	11/16	70,5	32,0	PHP 8-3V3350-F

F = 3 17/32" (89,70 mm)

10 Groove

Pitch Diameter P.D.	Outside diameter O.D.	Pulley type	Bushing	Bore		E	L	M	Weight lbs	Weight kg	Designation
				min	max						
Inch	Inch			Inch	Inch	Inch	Inch	Inch			
4,70	4,75	D-1	SK	1/2	2 5/8	21/32	1 15/16	3 1/16	18,3	8,3	PHP 10-3V475-SK
4,95	5,00	D-1	SK	1/2	2 5/8	21/32	1 15/16	3 1/16	20,9	9,5	PHP 10-3V500-SK
5,25	5,30	A-1	SK	1/2	2 5/8	21/32	1 15/16	1 3/4	22,5	10,2	PHP 10-3V530-SK
5,55	5,60	A-1	SK	1/2	2 5/8	21/32	1 15/16	1 3/4	25,1	11,4	PHP 10-3V560-SK
5,95	6,00	A-1	SK	1/2	2 5/8	21/32	1 15/16	1 3/4	32,0	14,5	PHP 10-3V600-SK
6,45	6,50	A-1	SK	1/2	2 5/8	21/32	1 15/16	1 3/4	38,6	17,5	PHP 10-3V650-SK
6,85	6,90	A-1	SK	1/2	2 5/8	21/32	1 15/16	1 3/4	44,1	20,0	PHP 10-3V690-SK
7,95	8,00	A-1	SF	1/2	2 15/16	21/32	2 1/16	1 5/8	52,9	24,0	PHP 10-3V800-SF
10,55	10,60	A-2	E	7/8	3 1/2	3/32	2 1/16	1 1/2	66,6	30,2	PHP 10-3V1060-E
13,95	14,00	A-3	E	7/8	3 1/2	3/32	2 1/16	1 1/2	94,4	42,8	PHP 10-3V1400-E
18,95	19,00	A-3	E	7/8	3 1/2	3/32	2 1/16	1 1/2	141,1	64,0	PHP 10-3V1900-E
24,95	25,00	D-3	F	1	4	1/32	3 3/4	5/8	218,3	99,0	PHP 10-3V2500-F
33,45	33,50	D-3	F	1	4	1/32	4 3/4	5/8	348,3	158,0	PHP 10-3V3350-F

F = 4 11/32" (110,33 mm)

Type A-1

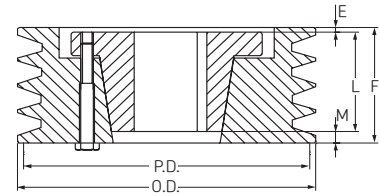

Type A-2

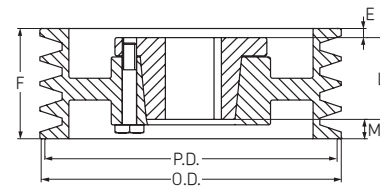

Type A-3

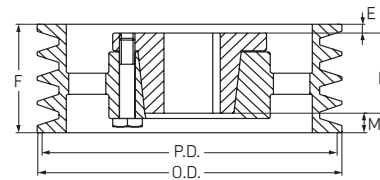

Type D-1

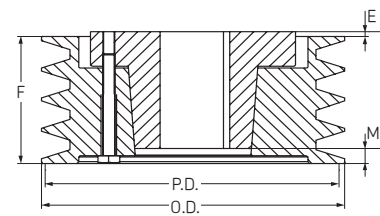

Type D-3

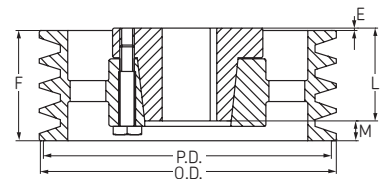



Narrow wedge belt pulleys

5V section QD bushed

- ▶ . Belts
- ▶ . Chains
- ▶ . Couplings
- ▶ . Bushings and Hubs
- ▶ . Sprockets
- ▶ . Pulleys
- ▶ . Smart tools

2 Groove

Pitch Diameter P.D.	Outside diameter O.D.	Pulley type	Bushing	Bore		E	L	M	Weight lbs	Weight kg	Designation
				min	max						
4,30	4,40	D-1	SH	1/2	1 5/8	1 11/32	1 5/16	2 3/32	12,8	5,8	PHP 2-5V440-SH
4,55	4,65	E-1	SDS	1/2	2	2 27/32	1 5/16	1 5/32	14,6	6,6	PHP 2-5V465-SDS
4,80	4,90	A-1	SDS	1/2	2	1 1/2	1 5/16	1 11/32	15,0	6,8	PHP 2-5V490-SDS
5,10	5,20	A-1	SDS	1/2	2	1 1/2	1 5/16	1 11/32	15,4	7,0	PHP 2-5V520-SDS
5,40	5,50	A-1	SDS	1/2	2	1 1/2	1 5/16	1 11/32	15,9	7,2	PHP 2-5V550-SDS
5,80	5,90	A-1	SDS	1/2	2	1 1/2	1 5/16	1 11/32	16,8	7,6	PHP 2-5V590-SDS
6,20	6,30	D-1	SK	1/2	2 5/8	1 11/32	1 15/16	3/32	20,7	9,4	PHP 2-5V630-SK
6,60	6,70	D-1	SK	1/2	2 5/8	1 11/32	1 15/16	3/32	23,1	10,5	PHP 2-5V670-SK
7,00	7,10	D-1	SK	1/2	2 5/8	1 11/32	1 15/16	3/32	25,4	11,5	PHP 2-5V710-SK
7,40	7,50	D-1	SK	1/2	2 5/8	1 11/32	1 15/16	3/32	27,6	12,5	PHP 2-5V750-SK
7,90	8,00	D-2	SK	1/2	2 5/8	1 11/32	1 15/16	3/32	28,7	13,0	PHP 2-5V800-SK
8,40	8,50	D-2	SK	1/2	2 5/8	1 11/32	1 15/16	3/32	30,9	14,0	PHP 2-5V850-SK
8,90	9,00	D-3	SK	1/2	2 5/8	1 11/32	1 5/16	3/32	33,5	15,2	PHP 2-5V900-SK
9,15	9,25	D-3	SK	1/2	2 5/8	1 11/32	1 5/16	3/32	33,7	15,3	PHP 2-5V925-SK
9,65	9,75	D-3	SK	1/2	2 5/8	1 11/32	1 15/16	3/32	34,2	15,5	PHP 2-5V975-SK
10,20	10,30	D-3	SK	1/2	2 5/8	1 11/32	1 15/16	3/32	34,2	15,5	PHP 2-5V1030-SK
10,80	10,90	D-3	SK	1/2	2 5/8	1 11/32	1 15/16	3/32	36,4	16,5	PHP 2-5V1090-SK
11,20	11,30	D-3	SK	1/2	2 5/8	1 11/32	1 15/16	3/32	39,2	17,8	PHP 2-5V1130-SK
11,70	11,80	D-3	SK	1/2	2 5/8	1 11/32	1 15/16	3/32	41,9	19,0	PHP 2-5V1180-SK
12,40	12,50	D-3	SF	1/2	2 15/16	1 13/32	2 1/16	1/32	46,3	21,0	PHP 2-5V1250-SF
13,10	13,20	D-3	SF	1/2	2 15/16	1 13/32	2 1/16	1/32	49,8	22,6	PHP 2-5V1320-SF
13,90	14,00	D-3	SF	1/2	2 15/16	1 13/32	2 1/16	1/32	55,8	25,3	PHP 2-5V1400-SF
14,90	15,00	D-3	SF	1/2	2 15/16	1 13/32	2 1/16	1/32	60,4	27,4	PHP 2-5V1500-SF
15,90	16,00	D-3	SF	1/2	2 15/16	1 13/32	2 1/16	1/32	64,4	29,2	PHP 2-5V1600-SF
18,60	18,70	D-3	SF	1/2	2 15/16	1 13/32	2 1/16	1/32	79,4	36,0	PHP 2-5V1870-SF
21,10	21,20	D-3	SF	1/2	2 15/16	1 13/32	2 1/16	1/32	94,8	43,0	PHP 2-5V2120-SF
23,50	23,60	C-3	E	7/8	3 1/2	2 29/32	2 3/4	5/32	121,3	55,0	PHP 2-5V2360-E
27,90	28,00	C-3	E	7/8	3 1/2	2 29/32	2 3/4	5/32	147,7	67,0	PHP 2-5V2800-E

F = 1 11/16" (42,86 mm)

3 Groove

Pitch Diameter P.D.	Outside diameter O.D.	Pulley type	Bushing	Bore		E	L	M	Weight lbs	Weight kg	Designation
				min	max						
4,30	4,40	E-1	SDS	1/2	2	1 23/32	1 5/16	2 1/32	14,3	6,5	PHP 3-5V440-SDS
4,55	4,65	E-1	SDS	1/2	2	1 23/32	1 5/16	2 1/32	16,8	7,6	PHP 3-5V465-SDS
4,80	4,90	A-1	SDS	1/2	2	1 13/32	1 5/16	2 1/32	17,2	7,8	PHP 3-5V490-SDS
5,10	5,20	A-1	SDS	1/2	2	1 13/32	1 5/16	2 1/32	17,6	8,0	PHP 3-5V520-SDS
5,40	5,50	A-1	SDS	1/2	2	1 13/32	1 5/16	2 1/32	18,1	8,2	PHP 3-5V550-SDS
5,80	5,90	A-1	SDS	1/2	2	1 13/32	1 5/16	2 1/32	19,0	8,6	PHP 3-5V590-SDS
6,20	6,30	A-1	SK	1/2	2 5/8	1 9/32	1 15/16	5/32	22,9	10,4	PHP 3-5V630-SK
6,60	6,70	A-1	SK	1/2	2 5/8	1 9/32	1 15/16	5/32	25,8	11,7	PHP 3-5V670-SK
7,00	7,10	A-1	SF	1/2	2 15/16	1 5/32	2 1/16	5/32	28,0	12,7	PHP 3-5V710-SF
7,40	7,50	A-1	SF	1/2	2 15/16	1 5/32	2 1/16	5/32	33,1	15,0	PHP 3-5V750-SF
7,90	8,00	A-1	SF	1/2	2 15/16	1 5/32	2 1/16	5/32	36,4	16,5	PHP 3-5V800-SF
8,40	8,50	A-3	SF	1/2	2 15/16	1 5/32	2 1/16	5/32	39,7	18,0	PHP 3-5V850-SF
8,90	9,00	A-3	SF	1/2	2 15/16	1 5/32	2 1/16	5/32	43,7	19,8	PHP 3-5V900-SF
9,15	9,25	A-3	SF	1/2	2 15/16	1 5/32	2 1/16	5/32	45,6	20,7	PHP 3-5V925-SF
9,65	9,75	A-3	SF	1/2	2 15/16	1 5/32	2 1/16	5/32	49,8	22,6	PHP 3-5V975-SF
10,20	10,30	A-3	SF	1/2	2 15/16	1 5/32	2 1/16	5/32	54,2	24,6	PHP 3-5V1030-SF
10,80	10,90	A-3	SF	1/2	2 15/16	1 5/32	2 1/16	5/32	58,9	26,7	PHP 3-5V1090-SF
11,20	11,30	A-3	SF	1/2	2 15/16	1 5/32	2 1/16	5/32	62,2	28,2	PHP 3-5V1130-SF
11,70	11,80	D-3	SF	1/2	2 15/16	1 5/32	2 1/16	5/32	65,5	29,7	PHP 3-5V1180-SF
12,40	12,50	D-3	E	7/8	3 1/2	1 13/32	2 3/4	1/32	75,0	34,0	PHP 3-5V1250-E
13,10	13,20	D-3	E	7/8	3 1/2	1 13/32	2 3/4	1/32	77,2	35,0	PHP 3-5V1320-E
13,90	14,00	D-3	E	7/8	3 1/2	1 13/32	2 3/4	1/32	81,6	37,0	PHP 3-5V1400-E
14,90	15,00	D-3	E	7/8	3 1/2	1 13/32	2 3/4	1/32	83,8	38,0	PHP 3-5V1500-E
15,90	16,00	D-3	E	7/8	3 1/2	1 13/32	2 3/4	1/32	86,4	39,2	PHP 3-5V1600-E
18,60	18,70	D-3	E	7/8	3 1/2	1 13/32	2 3/4	1/32	104,1	47,2	PHP 3-5V1870-E
21,10	21,20	D-3	E	7/8	3 1/2	1 13/32	2 3/4	1/32	121,3	55,0	PHP 3-5V2120-E
23,50	23,60	D-3	E	7/8	3 1/2	1 13/32	2 3/4	1/32	154,8	70,2	PHP 3-5V2360-E
27,90	28,00	D-3	E	7/8	3 1/2	1 13/32	2 3/4	1/32	190,7	86,5	PHP 3-5V2800-E
31,40	31,50	C-3	F	1	4	2 25/32	3 3/4	1 19/32	255,7	116,0	PHP 3-5V3150-F
37,40	37,50	C-3	F	1	4	2 25/32	3 3/4	1 19/32	310,9	141,0	PHP 3-5V3750-F
49,90	50,00	C-3	F	1	4	2 25/32	3 3/4	1 19/32	465,2	211,0	PHP 3-5V5000-F

F = 2 3/8" (60,33 mm)

Type A-1

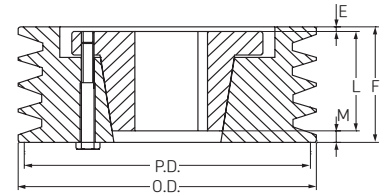

Type A-3

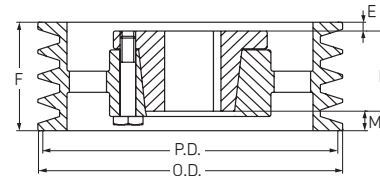

Type C-3

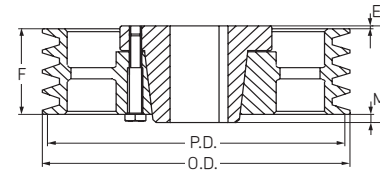

Type D-1

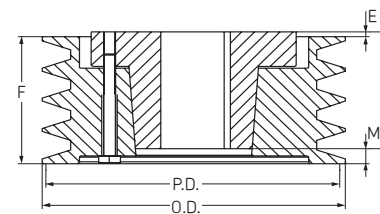

Type D-2

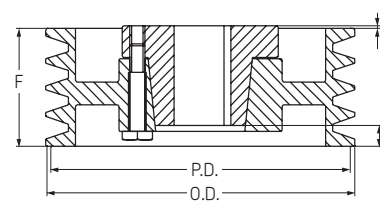

Type D-3

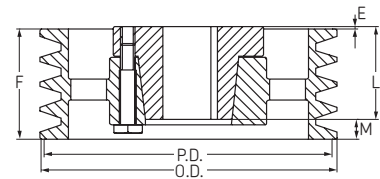

Type E-1

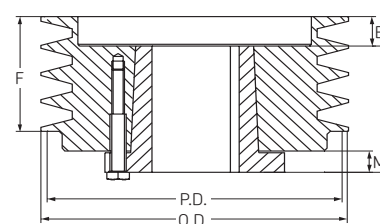



Narrow wedge belt pulleys

5V section QD bushed



4 Groove

Pitch Diameter P.D.	Outside diameter O.D.	Pulley type	Bushing	Bore		E	L	M	Weight lbs	Weight kg	Designation
				min	max						
Inch	Inch			Inch	Inch	Inch	Inch	Inch			
4,30	4,40	E-1	SD	1/2	2	1 29/32	1 13/16	21/32	16,5	7,5	PHP 4-5V440-SD
4,55	4,65	E-1	SD	1/2	2	1 29/32	1 13/16	21/32	17,6	8,0	PHP 4-5V465-SD
4,80	4,90	A-1	SD	1/2	2	21/32	1 13/16	19/32	18,7	8,5	PHP 4-5V490-SD
5,10	5,20	A-1	SD	1/2	2	21/32	1 13/16	19/32	19,4	8,8	PHP 4-5V520-SD
5,40	5,50	A-1	SD	1/2	2	21/32	1 13/16	19/32	20,5	9,3	PHP 4-5V550-SD
5,80	5,90	A-1	SD	1/2	2	21/32	1 13/16	19/32	22,3	10,1	PHP 4-5V590-SD
6,20	6,30	A-1	SK	1/2	2 5/8	17/32	1 15/16	19/32	26,0	11,8	PHP 4-5V630-SK
6,60	6,70	A-1	SK	1/2	2 5/8	17/32	1 15/16	19/32	30,0	13,6	PHP 4-5V670-SK
7,00	7,10	A-1	SF	1/2	2 15/16	7/32	2 1/16	25/32	32,8	14,9	PHP 4-5V710-SF
7,40	7,50	A-1	SF	1/2	2 15/16	7/32	2 1/16	25/32	37,5	17,0	PHP 4-5V750-SF
7,90	8,00	B-1	E	7/8	3 1/2	11/32	2 3/4	1/32	41,4	18,8	PHP 4-5V800-E
8,40	8,50	B-1	E	7/8	3 1/2	11/32	2 3/4	1/32	48,3	21,9	PHP 4-5V850-E
8,90	9,00	B-1	E	7/8	3 1/2	11/32	2 3/4	1/32	53,4	24,2	PHP 4-5V900-E
9,15	9,25	B-1	E	7/8	3 1/2	11/32	2 3/4	1/32	56,9	25,8	PHP 4-5V925-E
9,65	9,75	B-1	E	7/8	3 1/2	11/32	2 3/4	1/32	62,2	28,2	PHP 4-5V975-E
10,20	10,30	B-1	E	7/8	3 1/2	11/32	2 3/4	1/32	65,7	29,8	PHP 4-5V1030-E
10,80	10,90	B-2	E	7/8	3 1/2	11/32	2 3/4	1/32	67,5	30,6	PHP 4-5V1090-E
11,20	11,30	A-3	E	7/8	3 1/2	9/32	2 3/4	1/32	70,3	31,9	PHP 4-5V1130-E
11,70	11,80	B-2	E	7/8	3 1/2	11/32	2 3/4	1/32	72,8	33,0	PHP 4-5V1180-E
12,40	12,50	A-3	E	7/8	3 1/2	9/32	2 3/4	1/32	80,2	36,4	PHP 4-5V1250-E
13,10	13,20	A-3	E	7/8	3 1/2	9/32	2 3/4	1/32	84,2	38,2	PHP 4-5V1320-E
13,90	14,00	A-3	E	7/8	3 1/2	9/32	2 3/4	1/32	88,6	40,2	PHP 4-5V1400-E
14,90	15,00	A-3	E	7/8	3 1/2	9/32	2 3/4	1/32	95,9	43,5	PHP 4-5V1500-E
15,90	16,00	A-3	E	7/8	3 1/2	9/32	2 3/4	1/32	98,3	44,6	PHP 4-5V1600-E
18,60	18,70	A-3	E	7/8	3 1/2	3/32	2 3/4	1/32	118,2	53,6	PHP 4-5V1870-E
21,10	21,20	A-3	E	7/8	3 1/2	3/32	2 3/4	1/32	137,8	62,5	PHP 4-5V2120-E
23,50	23,60	C-3	F	1	4	15/32	3 3/4	7/32	184,1	83,5	PHP 4-5V2360-F
27,90	28,00	C-3	F	1	4	15/32	3 3/4	7/32	277,8	126,0	PHP 4-5V2800-F
31,40	31,50	C-3	F	1	4	15/32	3 3/4	7/32	326,3	148,0	PHP 4-5V3150-F
37,40	37,50	C-3	F	1	4	15/32	3 3/4	7/32	374,8	170,0	PHP 4-5V3750-F
49,90	50,00	C-3	J	1 1/2	4 1/2	3/4	4 5/8	13/16	546,7	248,0	PHP 4-5V5000-J

F = 3 1/16" (77,79 mm)

Type A-1

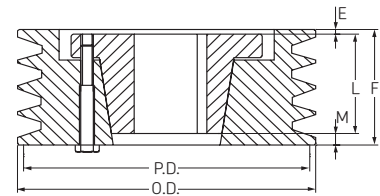

Type A-3

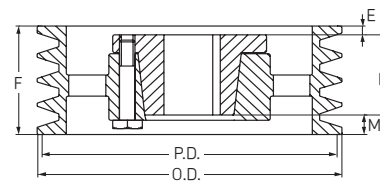

Type B-1

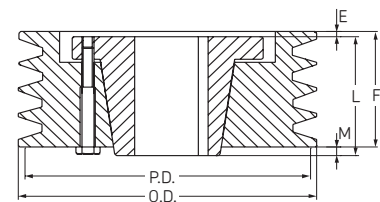

Type B-2

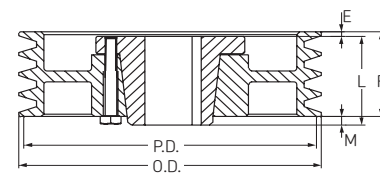

Type C-3

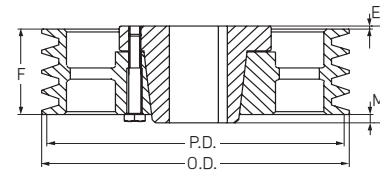

Type E-1

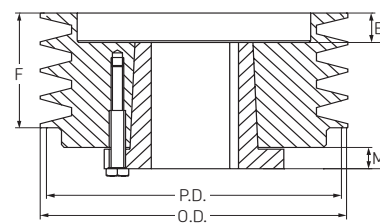



Narrow wedge belt pulleys

5V section QD bushed

- ▶ Belts
- ▶ Chains
- ▶ Couplings
- ▶ Bushings and Hubs
- ▶ Sprockets
- ▶ Pulleys
- ▶ Smart tools

5 Groove

Pitch Diameter P.D.	Outside diameter O.D.	Pulley type	Bushing	Bore		E	L	M	Weight lbs	Weight kg	Designation
				min	max						
Inch	Inch			Inch	Inch	Inch	Inch	Inch			
4,30	4,40	E-1	SD	1/2	2	2 19/32	1 13/16	21/32	19,6	8,9	PHP 5-5V440-SD
4,55	4,65	E-1	SD	1/2	2	2 19/32	1 13/16	21/32	20,3	9,2	PHP 5-5V465-SD
4,80	4,90	A-1	SD	1/2	2	21/32	1 13/16	19/32	22,3	10,1	PHP 5-5V490-SD
5,10	5,20	A-1	SD	1/2	2	21/32	1 13/16	19/32	23,8	10,8	PHP 5-5V520-SD
5,40	5,50	A-1	SD	1/2	2	21/32	1 13/16	19/32	26,5	12,0	PHP 5-5V550-SD
5,80	5,90	A-1	SK	1/2	2 5/8	17/32	1 15/16	15/32	29,1	13,2	PHP 5-5V590-SK
6,20	6,30	A-1	SK	1/2	2 5/8	17/32	1 15/16	15/32	35,1	15,9	PHP 5-5V630-SK
6,60	6,70	A-1	SF	1/2	2 15/16	17/32	2 1/16	13/32	41,0	18,6	PHP 5-5V670-SF
7,00	7,10	A-1	SF	1/2	2 15/16	17/32	2 1/16	13/32	47,8	21,7	PHP 5-5V710-SF
7,40	7,50	A-1	SF	1/2	2 15/16	17/32	2 1/16	13/32	50,3	22,8	PHP 5-5V750-SF
7,90	8,00	A-1	E	7/8	3 1/2	19/32	2 3/4	13/32	52,2	23,7	PHP 5-5V800-E
8,40	8,50	A-1	E	7/8	3 1/2	19/32	2 3/4	13/32	54,7	24,8	PHP 5-5V850-E
8,90	9,00	A-1	E	7/8	3 1/2	19/32	2 3/4	13/32	58,0	26,3	PHP 5-5V900-E
9,15	9,25	A-1	E	7/8	3 1/2	19/32	2 3/4	13/32	62,2	28,2	PHP 5-5V925-E
9,65	9,75	A-1	E	7/8	3 1/2	19/32	2 3/4	13/32	70,5	32,0	PHP 5-5V975-E
10,20	10,30	A-2	E	7/8	3 1/2	19/32	2 3/4	13/32	72,8	33,0	PHP 5-5V1030-E
10,80	10,90	A-2	E	7/8	3 1/2	19/32	2 3/4	13/32	77,2	35,0	PHP 5-5V1090-E
11,20	11,30	A-3	E	7/8	3 1/2	19/32	2 3/4	13/32	80,5	36,5	PHP 5-5V1130-E
11,70	11,80	A-3	E	7/8	3 1/2	19/32	2 3/4	13/32	83,8	38,0	PHP 5-5V1180-E
12,40	12,50	A-3	E	7/8	3 1/2	19/32	2 3/4	13/32	89,9	40,8	PHP 5-5V1250-E
13,10	13,20	A-3	E	7/8	3 1/2	19/32	2 3/4	13/32	93,3	42,3	PHP 5-5V1320-E
13,90	14,00	A-3	E	7/8	3 1/2	19/32	2 3/4	13/32	98,3	44,6	PHP 5-5V1400-E
14,90	15,00	A-3	E	7/8	3 1/2	19/32	2 3/4	13/32	106,3	48,2	PHP 5-5V1500-E
15,90	16,00	A-3	E	7/8	3 1/2	19/32	2 3/4	13/32	112,9	51,2	PHP 5-5V1600-E
18,60	18,70	D-3	F	1	4	1/2	3 3/4	1/2	154,8	70,2	PHP 5-5V1870-F
21,10	21,20	D-3	F	1	4	1/2	3 3/4	1/2	196,2	89,0	PHP 5-5V2120-F
23,50	23,60	D-3	F	1	4	1/2	3 3/4	1/2	231,5	105,0	PHP 5-5V2360-F
27,90	28,00	D-3	F	1	4	1/2	3 3/4	1/2	271,2	123,0	PHP 5-5V2800-F
31,40	31,50	C-3	J	1 1/2	4 1/2	7/16	4 5/8	7/16	332,9	151,0	PHP 5-5V3150-J
37,40	37,50	C-3	J	1 1/2	4 1/2	7/16	4 5/8	7/16	418,9	190,0	PHP 5-5V3750-J
49,90	50,00	C-3	J	1 1/2	4 1/2	7/16	4 5/8	7/16	612,9	278,0	PHP 5-5V5000-J

F = 3 3/4" (95,25 mm)

6 Groove

Pitch Diameter P.D.	Outside diameter O.D.	Pulley type	Bushing	Bore		E	L	M	Weight lbs	Weight kg	Designation
				min	max						
Inch	Inch			Inch	Inch	Inch	Inch	Inch			
4,30	4,40	E-1	SD	1/2	2	3 25/32	1 13/16	21/32	22,3	10,1	PHP 6-5V440-SD
4,55	4,65	E-1	SD	1/2	2	3 25/32	1 13/16	21/32	22,9	10,4	PHP 6-5V465-SD
4,80	4,90	A-1	SD	1/2	2	21/32	1 13/16	1 31/32	24,7	11,2	PHP 6-5V490-SD
5,10	5,20	A-1	SD	1/2	2	21/32	1 13/16	1 31/32	26,7	12,1	PHP 6-5V520-SD
5,40	5,50	A-1	SD	1/2	2	21/32	1 13/16	1 31/32	29,3	13,3	PHP 6-5V550-SD
5,80	5,90	A-1	SK	1/2	2 5/8	17/32	1 15/16	1 31/32	32,2	14,6	PHP 6-5V590-SK
6,20	6,30	A-1	SK	1/2	2 5/8	17/32	1 15/16	1 31/32	38,4	17,4	PHP 6-5V630-SK
6,60	6,70	A-1	SF	1/2	2 15/16	25/32	2 1/16	1 19/32	44,1	20,0	PHP 6-5V670-SF
7,00	7,10	A-1	SF	1/2	2 15/16	25/32	2 1/16	1 19/32	48,3	21,9	PHP 6-5V710-SF
7,40	7,50	A-1	SF	1/2	2 15/16	25/32	2 1/16	1 19/32	51,6	23,4	PHP 6-5V750-SF
7,90	8,00	A-1	E	7/8	3 1/2	27/32	2 3/4	27/32	53,4	24,2	PHP 6-5V800-E
8,40	8,50	A-1	E	7/8	3 1/2	27/32	2 3/4	27/32	58,9	26,7	PHP 6-5V850-E
8,90	9,00	A-1	E	7/8	3 1/2	27/32	2 3/4	27/32	62,8	28,5	PHP 6-5V900-E
9,15	9,25	A-1	E	7/8	3 1/2	27/32	2 3/4	27/32	66,6	30,2	PHP 6-5V925-E
9,65	9,75	A-1	E	7/8	3 1/2	27/32	2 3/4	27/32	74,5	33,8	PHP 6-5V975-E
10,20	10,30	A-2	E	7/8	3 1/2	27/32	2 3/4	27/32	80,7	36,6	PHP 6-5V1030-E
10,80	10,90	A-2	E	7/8	3 1/2	27/32	2 3/4	27/32	84,0	38,1	PHP 6-5V1090-E
11,20	11,30	A-3	E	7/8	3 1/2	27/32	2 3/4	27/32	87,7	39,8	PHP 6-5V1130-E
11,70	11,80	A-2	E	7/8	3 1/2	27/32	2 3/4	27/32	90,8	41,2	PHP 6-5V1180-E
12,40	12,50	B-3	F	1	4	23/32	3 3/4	1/2	128,3	58,2	PHP 6-5V1250-F
13,10	13,20	B-3	F	1	4	23/32	3 3/4	1/2	141,1	64,0	PHP 6-5V1320-F
13,90	14,00	B-3	F	1	4	23/32	3 3/4	1/2	145,5	66,0	PHP 6-5V1400-F
14,90	15,00	B-3	F	1	4	23/32	3 3/4	1/2	149,9	68,0	PHP 6-5V1500-F
15,90	16,00	B-3	F	1	4	23/32	3 3/4	1/2	170,9	77,5	PHP 6-5V1600-F
18,60	18,70	D-3	F	1	4	1/2	3 3/4	23/32	189,2	85,8	PHP 6-5V1870-F
21,10	21,20	D-3	F	1	4	1/2	3 3/4	23/32	211,6	96,0	PHP 6-5V2120-F
23,50	23,60	C-3	J	1 1/2	4 1/2	1/8	4 5/8	1/16	249,1	113,0	PHP 6-5V2360-J
27,90	28,00	C-3	J	1 1/2	4 1/2	1/8	4 5/8	1/16	326,3	148,0	PHP 6-5V2800-J
31,40	31,50	C-3	J	1 1/2	4 1/2	1/8	4 5/8	1/16	403,4	183,0	PHP 6-5V3150-J
37,40	37,50	C-3	J	1 1/2	4 1/2	1/8	4 5/8	1/16	480,6	218,0	PHP 6-5V3750-J
49,90	50,00	C-3	M	2	5 1/2	1 3/32	6 3/4	1 7/32	683,4	310,0	PHP 6-5V5000-M

F = 4 7/16" (112,71 mm)

Type A-1

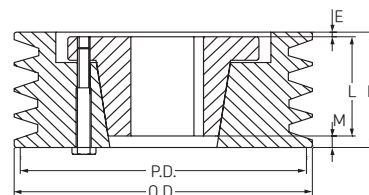

Type A-2

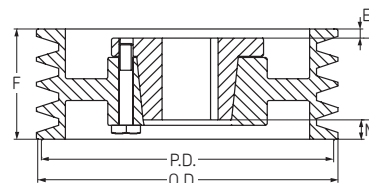

Type A-3

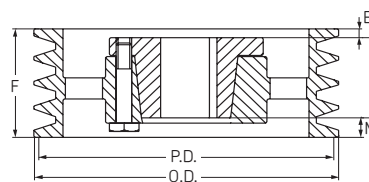

Type B-3

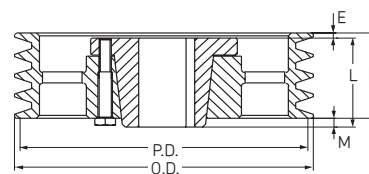

Type C-3

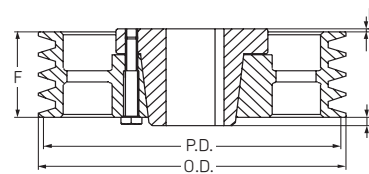

Type D-3

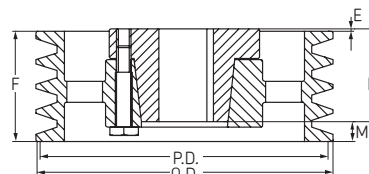

Type E-1

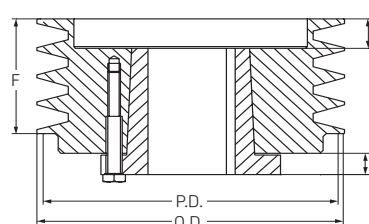



Narrow wedge belt pulleys

5V section QD bushed



8 Groove

Pitch Diameter P.D.	Outside diameter O.D.	Pulley type	Bushing	Bore		E	L	M	Weight lbs	Weight kg	Designation
				min	max						
Inch	Inch			Inch	Inch	Inch	Inch	Inch			
7,00	7,10	A-1	SF	1/2	2 15/16	1 9/32	2 1/16	2 15/32	54,5	24,7	PHP 8-5V710-SF
7,40	7,50	A-1	SF	1/2	2 15/16	1 9/32	2 1/16	2 15/32	62,2	28,2	PHP 8-5V750-SF
7,90	8,00	A-1	E	7/8	2 1/2	1 11/32	2 3/4	1 23/32	77,2	35,0	PHP 8-5V800-E
8,40	8,50	A-1	E	7/8	2 1/2	1 11/32	2 3/4	1 23/32	82,0	37,2	PHP 8-5V850-E
8,90	9,00	A-1	E	7/8	2 1/2	1 11/32	2 3/4	1 23/32	92,6	42,0	PHP 8-5V900-E
9,15	9,25	A-1	F	1	4	1 7/32	3 3/4	2 7/32	97,0	44,0	PHP 8-5V925-F
9,65	9,75	A-1	F	1	4	1 7/32	3 3/4	2 7/32	106,7	48,4	PHP 8-5V975-F
10,20	10,30	A-1	F	1	4	1 7/32	3 3/4	2 7/32	128,7	58,4	PHP 8-5V1030-F
10,80	10,90	A-1	F	1	4	1 7/32	3 3/4	2 7/32	139,1	63,1	PHP 8-5V1090-F
11,20	11,30	A-1	F	1	4	1 7/32	3 3/4	2 7/32	147,7	67,0	PHP 8-5V1130-F
11,70	11,80	A-2	F	1	4	1 7/32	3 3/4	2 7/32	156,5	71,0	PHP 8-5V1180-F
12,40	12,50	A-3	F	1	4	1 7/32	3 3/4	2 7/32	167,6	76,0	PHP 8-5V1250-F
13,10	13,20	A-3	F	1	4	1 7/32	3 3/4	2 7/32	176,4	80,0	PHP 8-5V1320-F
13,90	14,00	A-3	F	1	4	1 7/32	3 3/4	2 7/32	178,6	81,0	PHP 8-5V1400-F
14,90	15,00	A-3	F	1	4	1 7/32	3 3/4	2 7/32	183,0	83,0	PHP 8-5V1500-F
15,90	16,00	A-3	F	1	4	1 7/32	3 3/4	2 7/32	198,4	90,0	PHP 8-5V1600-F
18,60	18,70	A-3	J	1 1/2	4 1/2	1/8	4 5/8	1 1/16	264,6	120,0	PHP 8-5V1870-J
21,10	21,20	A-3	J	1 1/2	4 1/2	1/8	4 5/8	1 1/16	335,1	152,0	PHP 8-5V2120-J
23,50	23,60	A-3	J	1 1/2	4 1/2	1/8	4 5/8	1 1/16	407,9	185,0	PHP 8-5V2360-J
27,90	28,00	A-3	J	1 1/2	4 1/2	1/8	4 5/8	1 1/16	463,0	210,0	PHP 8-5V2800-J
31,40	31,50	B-3	M	2	5 1/2	11/32	6 3/4	1 9/32	533,5	242,0	PHP 8-5V3150-M
37,40	37,50	B-3	M	2	5 1/2	11/32	6 3/4	1 9/32	628,3	285,0	PHP 8-5V3750-M

F = 5 13/16" (147,64 mm)

Type A-1

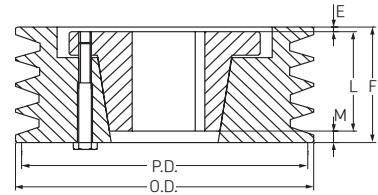

Type A-2

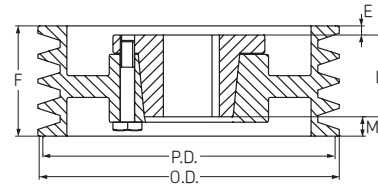

Type A-3

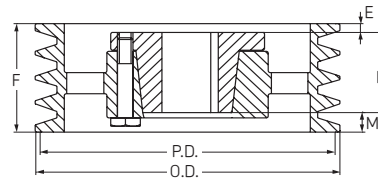

10 Groove

Pitch Diameter P.D.	Outside diameter O.D.	Pulley type	Bushing	Bore		E	L	M	Weight lbs	Weight kg	Designation
				min	max						
Inch	Inch			Inch	Inch	Inch	Inch	Inch			
7,90	8,00	A-1	E	7/8	3 1/2	2 3/32	2 3/4	2 11/32	82,9	37,6	PHP 10-5V800-E
8,40	8,50	A-1	E	7/8	3 1/2	2 3/32	2 3/4	2 11/32	98,1	44,5	PHP 10-5V850-E
8,90	9,00	A-1	F	1	4	1 31/32	3 3/4	1 15/32	113,1	51,3	PHP 10-5V900-F
9,15	9,25	A-1	F	1	4	1 31/32	3 3/4	1 15/32	116,8	53,0	PHP 10-5V925-F
9,65	9,75	A-1	F	1	4	1 31/32	3 3/4	1 15/32	123,5	56,0	PHP 10-5V975-F
10,20	10,30	A-1	F	1	4	1 31/32	3 3/4	1 15/32	141,1	64,0	PHP 10-5V1030-F
10,80	10,90	A-1	F	1	4	1 31/32	3 3/4	1 15/32	158,7	72,0	PHP 10-5V1090-F
11,20	11,30	A-1	F	1	4	1 31/32	3 3/4	1 15/32	169,8	77,0	PHP 10-5V1130-F
11,70	11,80	A-2	F	1	4	1 31/32	3 3/4	1 15/32	178,6	81,0	PHP 10-5V1180-F
12,40	12,50	A-2	J	1 1/2	4 1/2	2 1/8	4 5/8	7/16	246,9	112,0	PHP 10-5V1250-J
13,10	13,20	A-2	J	1 1/2	4 1/2	2 1/8	4 5/8	7/16	255,7	116,0	PHP 10-5V1320-J
13,90	14,00	A-3	J	1 1/2	4 1/2	2 1/8	4 5/8	7/16	286,6	130,0	PHP 10-5V1400-J
14,90	15,00	A-3	J	1 1/2	4 1/2	2 1/8	4 5/8	7/16	304,2	138,0	PHP 10-5V1500-J
15,90	16,00	A-3	J	1 1/2	4 1/2	2 1/8	4 5/8	7/16	321,9	146,0	PHP 10-5V1600-J
18,60	18,70	A-3	J	1 1/2	4 1/2	1/8	4 5/8	2 7/16	346,1	157,0	PHP 10-5V1870-J
21,10	21,20	A-3	J	1 1/2	4 1/2	1/8	4 5/8	2 7/16	370,4	168,0	PHP 10-5V2120-J
23,50	23,60	A-3	M	2	5 1/2	11/32	6 3/4	3/32	469,6	213,0	PHP 10-5V2360-M
27,90	28,00	A-3	M	2	5 1/2	11/32	6 3/4	3/32	529,1	240,0	PHP 10-5V2800-M
31,40	31,50	A-3	M	2	5 1/2	11/32	6 3/4	3/32	606,3	275,0	PHP 10-5V3150-M
37,40	37,50	A-3	M	2	5 1/2	11/32	6 3/4	3/32	694,5	315,0	PHP 10-5V3750-M
49,90	50,00	A-3	M	2	5 1/2	11/32	6 3/4	3/32	1009,7	458,0	PHP 10-5V5000-M

F = 7 3/16" (182,56 mm)

Type B-3

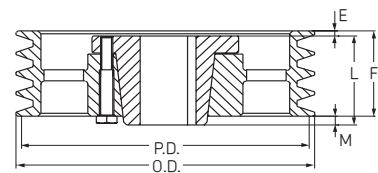



Narrow wedge belt pulleys

8V section QD bushed

- ▶ Belts
- ▶ Chains
- ▶ Couplings
- ▶ Bushings and Hubs
- ▶ Sprockets
- ▶ Pulleys
- ▶ Smart tools

Type A-1

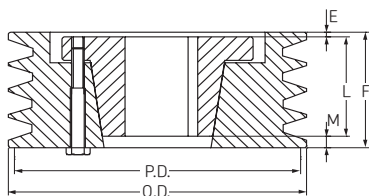

Type B-3

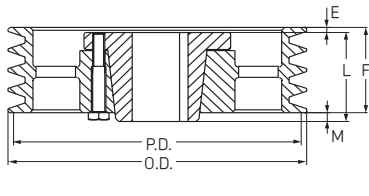

Type D-2

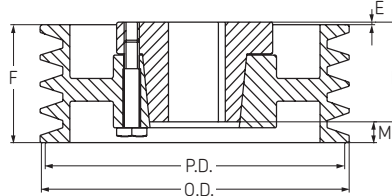

Type A-3

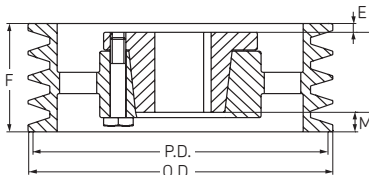

Type C-3

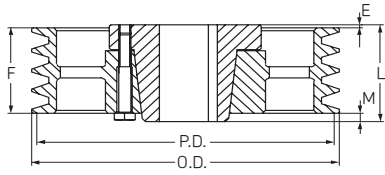

Type D-3

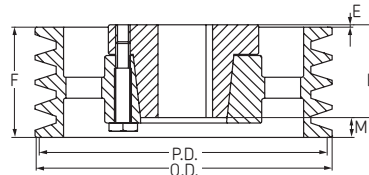

4 Groove

Pitch Diameter P.D.	Outside diameter O.D.	Pulley type	Bushing	Bore		E	L	M	Weight lbs	Weight kg	Designation
				min	max						
Inch	Inch			Inch	Inch	Inch	Inch	Inch			
12,3	12,5	D-2	F	1	4	5/32	3 3/4	1 1/32	165,3	75,0	PHP 4-8V1250-F
13,0	13,2	D-2	F	1	4	5/32	3 3/4	1 1/32	178,6	81,0	PHP 4-8V1320-F
13,8	14,0	D-3	F	1	4	5/32	3 3/4	1 1/32	191,8	87,0	PHP 4-8V1400-F
14,8	15,0	D-3	F	1	4	5/32	3 3/4	1 1/32	200,6	91,0	PHP 4-8V1500-F
15,8	16,0	D-3	F	1	4	5/32	3 3/4	1 1/32	211,6	96,0	PHP 4-8V1600-F
16,8	17,0	D-3	F	1	4	5/32	3 3/4	1 1/32	229,3	104,0	PHP 4-8V1700-F
17,8	18,0	D-3	F	1	4	5/32	3 3/4	1 1/32	251,3	114,0	PHP 4-8V1800-F
18,8	19,0	D-3	F	1	4	5/32	3 3/4	1 1/32	266,8	121,0	PHP 4-8V1900-F
19,8	20,0	D-3	J	1 1/2	4 1/2	0	4 5/8	1/4	299,8	136,0	PHP 4-8V2000-J
21,0	21,2	D-3	J	1 1/2	4 1/2	0	4 5/8	1/4	319,7	145,0	PHP 4-8V2120-J
22,2	22,4	D-3	J	1 1/2	4 1/2	0	4 5/8	1/4	339,5	154,0	PHP 4-8V2240-J
24,6	24,8	C-3	M	2	5 1/2	25/32	6 3/4	1 3/32	388,0	176,0	PHP 4-8V2480-M
29,8	30,0	C-3	M	2	5 1/2	25/32	6 3/4	1 3/32	493,8	224,0	PHP 4-8V3000-M
35,3	35,5	C-3	M	2	5 1/2	25/32	6 3/4	1 3/32	588,6	267,0	PHP 4-8V3550-M
39,8	40,0	C-3	M	2	5 1/2	25/32	6 3/4	1 3/32	683,4	310,0	PHP 4-8V4000-M
44,3	44,5	C-3	M	2	5 1/2	25/32	6 3/4	1 3/32	800,3	363,0	PHP 4-8V4450-M
52,8	53,0	C-3	M	2	5 1/2	25/32	6 3/4	1 3/32	963,4	437,0	PHP 4-8V5300-M

F = 4 7/8" (123,83 mm)

5 Groove

Pitch Diameter P.D.	Outside diameter O.D.	Pulley type	Bushing	Bore		E	L	M	Weight lbs	Weight kg	Designation
				min	max						
Inch	Inch			Inch	Inch	Inch	Inch	Inch			
12,3	12,5	A-2	F	1	4	31/32	3 3/4	1 1/32	180,8	82,0	PHP 5-8V1250-F
13,0	13,2	A-2	F	1	4	31/32	3 3/4	1 1/32	196,2	89,0	PHP 5-8V1320-F
13,8	14,0	A-3	F	1	4	31/32	3 3/4	1 1/32	218,3	99,0	PHP 5-8V1400-F
14,8	15,0	A-3	F	1	4	31/32	3 3/4	1 1/32	227,1	103,0	PHP 5-8V1500-F
15,8	16,0	A-3	F	1	4	31/32	3 3/4	1 1/32	244,7	111,0	PHP 5-8V1600-F
16,8	17,0	A-3	J	1 1/2	4 1/2	9/16	4 5/8	13/16	262,4	119,0	PHP 5-8V1700-J
17,8	18,0	A-3	J	1 1/2	4 1/2	9/16	4 5/8	13/16	288,8	131,0	PHP 5-8V1800-J
18,8	19,0	A-3	J	1 1/2	4 1/2	9/16	4 5/8	13/16	313,1	142,0	PHP 5-8V1900-J
19,8	20,0	A-3	J	1 1/2	4 1/2	9/16	4 5/8	13/16	332,9	151,0	PHP 5-8V2000-J
21,0	21,2	A-3	J	1 1/2	4 1/2	9/16	4 5/8	13/16	368,2	167,0	PHP 5-8V2120-J
22,2	22,4	B-3	M	2	5 1/2	11/32	6 3/4	1 3/32	392,4	178,0	PHP 5-8V2240-M
24,6	24,8	B-3	M	2	5 1/2	11/32	6 3/4	1 3/32	443,1	201,0	PHP 5-8V2480-M
29,8	30,0	B-3	M	2	5 1/2	11/32	6 3/4	1 3/32	535,7	243,0	PHP 5-8V3000-M
35,3	35,5	B-3	M	2	5 1/2	11/32	6 3/4	1 3/32	612,9	278,0	PHP 5-8V3550-M
39,8	40,0	B-3	M	2	5 1/2	11/32	6 3/4	1 3/32	749,6	340,0	PHP 5-8V4000-M
44,3	44,5	C-3	N	2 7/16	5 7/16	1 1/8	8 1/8	1	921,5	418,0	PHP 5-8V4450-N
52,8	53,0	C-3	N	2 7/16	5 7/16	1 1/8	8 1/8	1	1093,5	496,0	PHP 5-8V5300-N

F = 6 (152,40 mm)



Narrow wedge belt pulleys

8V section QD bushed



Type A-1

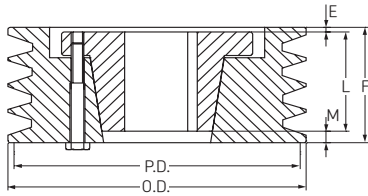

Type A-3

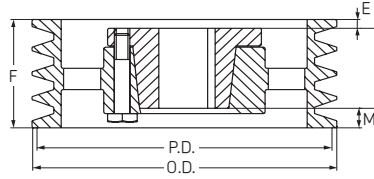

Type C-3

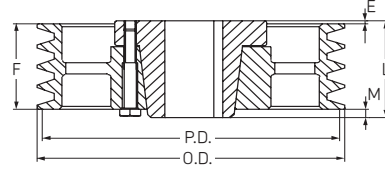

Type A-2

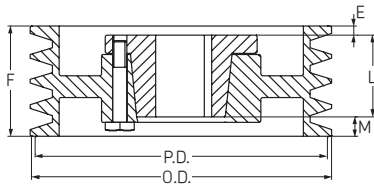

Type B-3

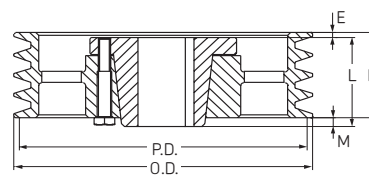

6 Groove

Pitch Diameter P.D.	Outside diameter O.D.	Pulley type	Bushing	Bore		E	L	M	Weight lbs	Weight kg	Designation
				min	max						
Inch	Inch			Inch	Inch	Inch	Inch	Inch			
12,3	12,5	A-2	F	1	4	³¹ / ₃₂	3 ³ / ₄	2 ¹³ / ₃₂	198,4	90,0	PHP 6-8V1250-F
13,0	13,2	A-2	F	1	4	³¹ / ₃₂	3 ³ / ₄	2 ¹³ / ₃₂	216,1	98,0	PHP 6-8V1320-F
13,8	14,0	A-2	F	1	4	³¹ / ₃₂	3 ³ / ₄	2 ¹³ / ₃₂	246,9	112,0	PHP 6-8V1400-F
14,8	15,0	A-3	J	1 ¹ / ₂	4 ¹ / ₂	1 ¹ / ₈	4 ⁵ / ₈	1 ³ / ₈	271,2	123,0	PHP 6-8V1500-J
15,8	16,0	A-3	J	1 ¹ / ₂	4 ¹ / ₂	1 ¹ / ₈	4 ⁵ / ₈	1 ³ / ₈	284,4	129,0	PHP 6-8V1600-J
16,8	17,0	A-3	J	1 ¹ / ₂	4 ¹ / ₂	1 ¹ / ₈	4 ⁵ / ₈	1 ³ / ₈	299,8	136,0	PHP 6-8V1700-J
17,8	18,0	A-3	J	1 ¹ / ₂	4 ¹ / ₂	1 ¹ / ₈	4 ⁵ / ₈	1 ³ / ₈	315,3	143,0	PHP 6-8V1800-J
18,8	19,0	A-3	J	1 ¹ / ₂	4 ¹ / ₂	1 ¹ / ₈	4 ⁵ / ₈	1 ³ / ₈	346,1	157,0	PHP 6-8V1900-J
19,8	20,0	B-3	M	2	5 ¹ / ₂	1 ¹¹ / ₃₂	6 ³ / ₄	³¹ / ₃₂	394,6	179,0	PHP 6-8V2000-M
21,0	21,2	B-3	M	2	5 ¹ / ₂	1 ¹¹ / ₃₂	6 ³ / ₄	³¹ / ₃₂	425,5	193,0	PHP 6-8V2120-M
22,2	22,4	B-3	M	2	5 ¹ / ₂	1 ¹¹ / ₃₂	6 ³ / ₄	³¹ / ₃₂	451,9	205,0	PHP 6-8V2240-M
24,6	24,8	A-3	M	2	5 ¹ / ₂	¹¹ / ₃₂	6 ³ / ₄	¹ / ₃₂	518,1	235,0	PHP 6-8V2480-M
29,8	30,0	A-3	M	2	5 ¹ / ₂	¹¹ / ₃₂	6 ³ / ₄	¹ / ₃₂	628,3	285,0	PHP 6-8V3000-M
35,3	35,5	C-3	N	2 ⁷ / ₁₆	5 ⁷ / ₁₆	¹⁵ / ₁₆	8 ¹ / ₈	¹ / ₁₆	749,6	340,0	PHP 6-8V3550-N
39,8	40,0	C-3	N	2 ⁷ / ₁₆	6 ⁷ / ₁₆	¹⁵ / ₁₆	8 ¹ / ₈	¹ / ₁₆	868,6	394,0	PHP 6-8V4000-N
44,3	44,5	C-3	N	2 ⁷ / ₁₆	7 ⁷ / ₁₆	¹⁵ / ₁₆	8 ¹ / ₈	¹ / ₁₆	1078,1	489,0	PHP 6-8V4450-N
52,8	53,0	C-3	N	2 ⁷ / ₁₆	8 ⁷ / ₁₆	¹⁵ / ₁₆	8 ¹ / ₈	¹ / ₁₆	1287,5	584,0	PHP 6-8V5300-N

F = 7 1/8" (180,98 mm)

8 Groove

Pitch Diameter P.D.	Outside diameter O.D.	Pulley type	Bushing	Bore		E	L	M	Weight lbs	Weight kg	Designation
				min	max						
Inch	Inch			Inch	Inch	Inch	Inch	Inch			
12,3	12,5	A-1	J	1 ¹ / ₂	4 ¹ / ₂	2 ¹ / ₈	4 ⁵ / ₈	2 ⁵ / ₈	288,8	131,0	PHP 8-8V1250-J
13,0	13,2	A-1	J	1 ¹ / ₂	4 ¹ / ₂	2 ¹ / ₈	4 ⁵ / ₈	2 ⁵ / ₈	352,7	160,0	PHP 8-8V1320-J
13,8	14,0	A-2	J	1 ¹ / ₂	4 ¹ / ₂	2 ¹ / ₈	4 ⁵ / ₈	2 ⁵ / ₈	385,8	175,0	PHP 8-8V1400-J
14,8	15,0	A-2	J	1 ¹ / ₂	4 ¹ / ₂	2 ¹ / ₈	4 ⁵ / ₈	2 ⁵ / ₈	410,1	186,0	PHP 8-8V1500-J
15,8	16,0	A-2	J	1 ¹ / ₂	4 ¹ / ₂	2 ¹ / ₈	4 ⁵ / ₈	2 ⁵ / ₈	463,0	210,0	PHP 8-8V1600-J
16,8	17,0	A-2	M	2	5 ¹ / ₂	2 ¹¹ / ₃₂	6 ³ / ₄	⁹ / ₃₂	487,2	221,0	PHP 8-8V1700-M
17,8	18,0	A-2	M	2	5 ¹ / ₂	2 ¹¹ / ₃₂	6 ³ / ₄	⁹ / ₃₂	518,1	235,0	PHP 8-8V1800-M
18,8	19,0	A-3	M	2	5 ¹ / ₂	2 ¹¹ / ₃₂	6 ³ / ₄	⁹ / ₃₂	551,2	250,0	PHP 8-8V1900-M
19,8	20,0	A-3	M	2	5 ¹ / ₂	2 ¹¹ / ₃₂	6 ³ / ₄	⁹ / ₃₂	584,2	265,0	PHP 8-8V2000-M
21,1	21,2	A-3	M	2	5 ¹ / ₂	2 ¹¹ / ₃₂	6 ³ / ₄	⁹ / ₃₂	617,3	280,0	PHP 8-8V2120-M
22,2	22,4	A-3	M	2	5 ¹ / ₂	2 ¹¹ / ₃₂	6 ³ / ₄	⁹ / ₃₂	650,4	295,0	PHP 8-8V2240-M
24,6	24,8	A-2	N	2 ⁷ / ₁₆	5 ⁷ / ₁₆	³ / ₁₆	8 ¹ / ₈	¹¹ / ₁₆	705,5	320,0	PHP 8-8V2480-N
29,8	30,0	A-3	N	2 ⁷ / ₁₆	5 ⁷ / ₁₆	³ / ₁₆	8 ¹ / ₈	¹¹ / ₁₆	826,7	375,0	PHP 8-8V3000-N
35,3	35,5	A-3	N	2 ⁷ / ₁₆	5 ⁷ / ₁₆	³ / ₁₆	8 ¹ / ₈	¹¹ / ₁₆	974,4	442,0	PHP 8-8V3550-N
39,8	40,0	A-3	N	2 ⁷ / ₁₆	5 ⁷ / ₁₆	³ / ₁₆	8 ¹ / ₈	¹¹ / ₁₆	1168,4	530,0	PHP 8-8V4000-N
44,3	44,5	B-3	P	2 ¹⁵ / ₁₆	7	¹ / ₄	9 ³ / ₈	¹ / ₄	1344,8	610,0	PHP 8-8V4450-P
52,8	53,0	B-3	P	2 ¹⁵ / ₁₆	7	¹ / ₄	9 ³ / ₈	¹ / ₄	1752,7	795,0	PHP 8-8V5300-P

F = 9 3/8" (238,13 mm)



Narrow wedge belt pulleys

8V section QD bushed

- ▶ Belts
- ▶ Chains
- ▶ Couplings
- ▶ Bushings and Hubs
- ▶ Sprockets
- ▶ Pulleys
- ▶ Smart tools

Type A-1

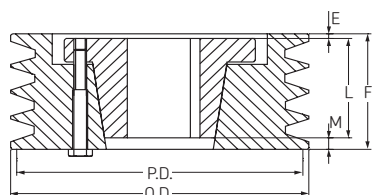

Type A-3

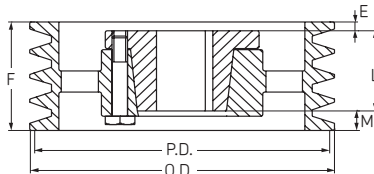

Type A-2

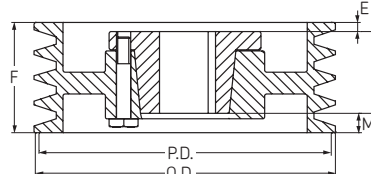

10 Groove

Pitch Diameter P.D.	Outside diameter O.D.	Pulley type	Bushing	Bore		E	L	M	Weight lbs	Weight kg	Designation
				min	max						
Inch	Inch			Inch	Inch	Inch	Inch	Inch			
12,3	12,5	A-1	J	1 1/2	4 1/2	2 1/8	4 5/8	4 7/6	341,7	155,0	PHP 10-8V1250-J
13,0	13,2	A-1	J	1 1/2	4 1/2	2 1/8	4 5/8	4 7/6	418,9	190,0	PHP 10-8V1320-J
13,8	14,0	A-1	J	1 1/2	4 1/2	2 1/8	4 5/8	4 7/6	463,0	210,0	PHP 10-8V1400-J
14,8	15,0	A-1	M	2	5 1/2	2 11/32	6 3/4	2 17/32	586,4	266,0	PHP 10-8V1500-M
15,8	16,0	A-2	M	2	5 1/2	2 11/32	6 3/4	2 17/32	564,4	256,0	PHP 10-8V1600-M
16,8	17,0	A-1	M	2	5 1/2	2 11/32	6 3/4	2 17/32	619,5	281,0	PHP 10-8V1700-M
17,8	18,0	A-2	M	2	5 1/2	2 11/32	6 3/4	2 17/32	639,3	290,0	PHP 10-8V1800-M
18,8	19,0	A-2	M	2	5 1/2	2 11/32	6 3/4	2 17/32	663,6	301,0	PHP 10-8V1900-M
19,8	20,0	A-2	M	2	5 1/2	2 11/32	6 3/4	2 17/32	716,5	325,0	PHP 10-8V2000-M
21,0	21,2	A-2	M	2	5 1/2	2 11/32	6 3/4	2 17/32	749,6	340,0	PHP 10-8V2120-M
22,2	22,4	A-2	N	2 7/16	5 7/16	3 1/16	8 1/8	3 5/16	804,7	365,0	PHP 10-8V2240-N
24,6	24,8	A-2	N	2 7/16	5 7/16	3 1/16	8 1/8	3 5/16	859,8	390,0	PHP 10-8V2480-N
29,8	30,0	A-3	N	2 7/16	5 7/16	3 1/16	8 1/8	3 5/16	959,0	435,0	PHP 10-8V3000-N
35,3	35,5	A-2	P	2 15/16	7	1/4	9 3/8	2	1117,7	507,0	PHP 10-8V3550-P
39,8	40,0	A-3	P	2 15/16	7	1/4	9 3/8	2	1355,8	615,0	PHP 10-8V4000-P
44,3	44,5	A-2	P	2 15/16	7	1/4	9 3/8	2	1565,3	710,0	PHP 10-8V4450-P
52,8	53,0	A-3	P	2 15/16	7	1/4	9 3/8	2	2083,4	945,0	PHP 10-8V5300-P

F = 11 5/8" (295,28 mm)

12 Groove

Pitch Diameter P.D.	Outside diameter O.D.	Pulley type	Bushing	Bore		E	L	M	Weight lbs	Weight kg	Designation
				min	max						
Inch	Inch			Inch	Inch	Inch	Inch	Inch			
12,3	12,5	A-1	M	2	5 1/2	2 11/32	6 3/4	4 25/32	429,9	195,0	PHP 12-8V1250-M
13,0	13,2	A-1	M	2	5 1/2	2 11/32	6 3/4	4 25/32	507,1	230,0	PHP 12-8V1320-M
13,8	14,0	A-1	M	2	5 1/2	2 11/32	6 3/4	4 25/32	551,2	250,0	PHP 12-8V1400-M
14,8	15,0	A-1	M	2	5 1/2	2 11/32	6 3/4	4 25/32	590,8	268,0	PHP 12-8V1500-M
15,8	16,0	A-1	M	2	5 1/2	2 11/32	6 3/4	4 25/32	652,6	296,0	PHP 12-8V1600-M
16,8	17,0	A-1	M	2	5 1/2	2 11/32	6 3/4	4 25/32	751,8	341,0	PHP 12-8V1700-M
17,8	18,0	A-1	M	2	5 1/2	2 11/32	6 3/4	4 25/32	760,6	345,0	PHP 12-8V1800-M
18,8	19,0	A-1	N	2 7/16	5 7/16	3 1/16	8 1/8	5 9/16	776,0	352,0	PHP 12-8V1900-N
19,8	20,0	A-1	N	2 7/16	5 7/16	3 1/16	8 1/8	5 9/16	848,8	385,0	PHP 12-8V2000-N
21,0	21,2	A-1	N	2 7/16	5 7/16	3 1/16	8 1/8	5 9/16	881,8	400,0	PHP 12-8V2120-N
22,2	22,4	A-1	N	2 7/16	5 7/16	3 1/16	8 1/8	5 9/16	959,0	435,0	PHP 12-8V2240-N
24,6	24,8	A-1	N	2 7/16	5 7/16	3 1/16	8 1/8	5 9/16	1014,1	460,0	PHP 12-8V2480-N
29,8	30,0	A-2	P	2 15/16	7	1/4	9 3/8	4 1/4	1091,3	495,0	PHP 12-8V3000-P
35,3	35,5	A-2	P	2 15/16	7	1/4	9 3/8	4 1/4	1261,0	572,0	PHP 12-8V3550-P
39,8	40,0	A-2	P	2 15/16	7	1/4	9 3/8	4 1/4	1543,2	700,0	PHP 12-8V4000-P
44,3	44,5	A-2	P	2 15/16	7	1/4	9 3/8	4 1/4	1818,8	825,0	PHP 12-8V4450-P
52,8	53,0	A-2	P	2 15/16	7	1/4	9 3/8	4 1/4	2381,0	1080,0	PHP 12-8V5300-P

F = 13 3/8" (352,43 mm)

Smart Tools





Belt tools

SKF Belt Frequency Meter PHL FM 10/400

Most accurate belt tension measurement instrument

Correct belt tension is crucial for the whole belt drive, its service life and the service life of associated bearings. Therefore, it is important to get accurate and reliable results when it comes to belt tension measurement.

The SKF Belt Frequency Meter is one of the most accurate tools available for measuring the belt tension on a belt drive. Results are quickly achieved, reliable and - most importantly - repeatable. The tool is also extremely easy-to-use, while minimizing the risk for human errors. Thus, the SKF Belt Frequency Meter is ideal for measuring the belt tension.

Wide range of applications

The two component system, consisting of a hand-held meter attached to an optical sensor, offers contact-free belt tension measurement for most of the following belt types – even in a noisy environment:

- V-Belts (wrapped, cogged raw edge, ribbed)
- Banded V-Belts
- Timing belts

The SKF Belt Frequency Meter is capable of measuring belt vibration frequencies from 10 to 400 Hz. Based upon the measured belt frequency the SKF Belt Frequency Meter calculates belt tensions up to 9 900 N (2 200 lbs.)

Easy and quick to use:

- Simply key in the span length and mass data. Data can also be saved and recalled for repeated use, if necessary
- Aim sensor at centre of selected belt span and pluck or tap the belt
- The display will show the measured frequency which can be toggled to either newton or pounds values
- Readjust the belt tension, if necessary and take another measurement



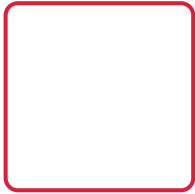

Belt tools

SKF Belt Tension System

- ▶ Belts
- ▶ Chains
- ▶ Couplings
- ▶ Bushings and Hubs
- ▶ Sprockets
- ▶ Pulleys
- ▶ Smart tools

High quality belt drive maintenance – with reduced time and effort

The SKF Belt Tension System offers an innovative solution for belt drives by facilitating belt maintenance and replacement, while offering a higher efficiency. Only by connecting a hand-held hydraulic pump the cylinders of the SKF Belt Tension System are moved up and downwards. This enables a controlled moving of the motor axis which is directly related to the belt tension and the pressure in the cylinders. This unique function allows for quick and easy belt tension checks as well as belt replacements.

Additional required and recommended tools:

Only a hammer and a hand-held hydraulic pump, such as the SKF THPT1, are required for using the SKF Belt Tension System. Additionally, it is recommended to use a laser alignment tool, e.g. the SKF Belt Alignment Tool TMEB 2, and the SKF Belt Frequency Meter for checking the tension of the belt when the SKF Belt Tension System is initially installed.

Selection guide for the SKF Belt Tension System:

Designation	IEC Motor class
PHL 160/180 H1	160 and 180
PHL 200/225 H1	200 and 225
PHL 250/280 H1	250 and 280
PHL 315 H1	315
PHL 355 H1	355
PHL 400 H1	400

In addition several NEMA standard motors can be mounted on the SKF Belt Tension System. In this case, please contact SKF for additional information.

Various benefits for the belt drive are achieved:

- Alignment is necessary only once, independent from number of belt replacements
- Safe, simple and fast belt replacement
- Reduced costs due to prolonged belt life
- Higher uptime of the whole system due to less time-consuming breakdowns
- Less vibrations and therefore also higher efficiency
- Quick and reliable tension checks
- Easy preventive maintenance
- Assured repeatable maintenance quality

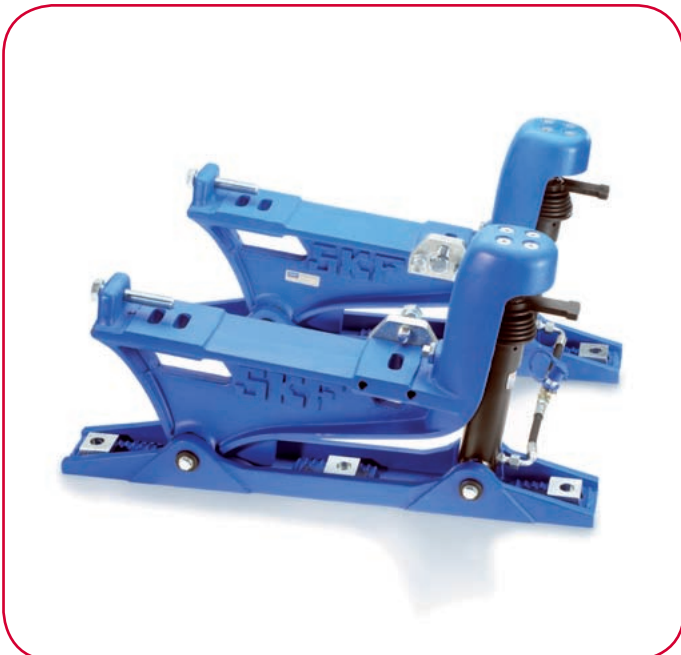



Belt tools

SKF Belt Alignment Tool TMEB 2

Belt-driven machinery downtime caused by misalignment is a thing of the past

The SKF Belt Alignment Tool, TMEB 2, aligns the pulleys where it counts most – in the grooves. V-guides and powerful magnets allow the TMEB 2 to be fitted in the grooves of the pulley. With only two components, a laser-emitting unit and a receiver unit, the TMEB 2 is easy and fast to attach. The three-dimensional target area on the receiver unit allows the easy detection of misalignment

as well as its nature; whether it is horizontal, vertical, parallel or a combination of all three. Armed with this precise information, the operator can easily make the appropriate adjustments until the laser line corresponds with the reference line on the receiver unit.

Pinpoint accuracy with laser technology:

- Aligns grooves of the pulley rather than its face, allowing the alignment of pulleys of unequal width or with dissimilar faces - even fits applications where the pulley face cannot be used as a reference
- No trial and error. The laser position indicates the nature of misalignment allowing easy and accurate adjustment

Versatile and user-friendly:

- Powerful magnets allow fast and easy attachment
- Easy-to-use, requires no special training to operate
- Three-dimensional target area simplifies the alignment process
- Facilitates simultaneous adjustment of tension and alignment
- V-guides facilitate the alignment of a wide range of V-belt pulleys
- Special side adaptor allowing alignment of multi-ribbed and timing belt pulleys as well as chain sprockets is available as accessory
- A maximum operating distance of 6 meters (20 ft) makes it suitable for use in various applications
- Sturdy aluminium housings provide great assembly stability and accuracy

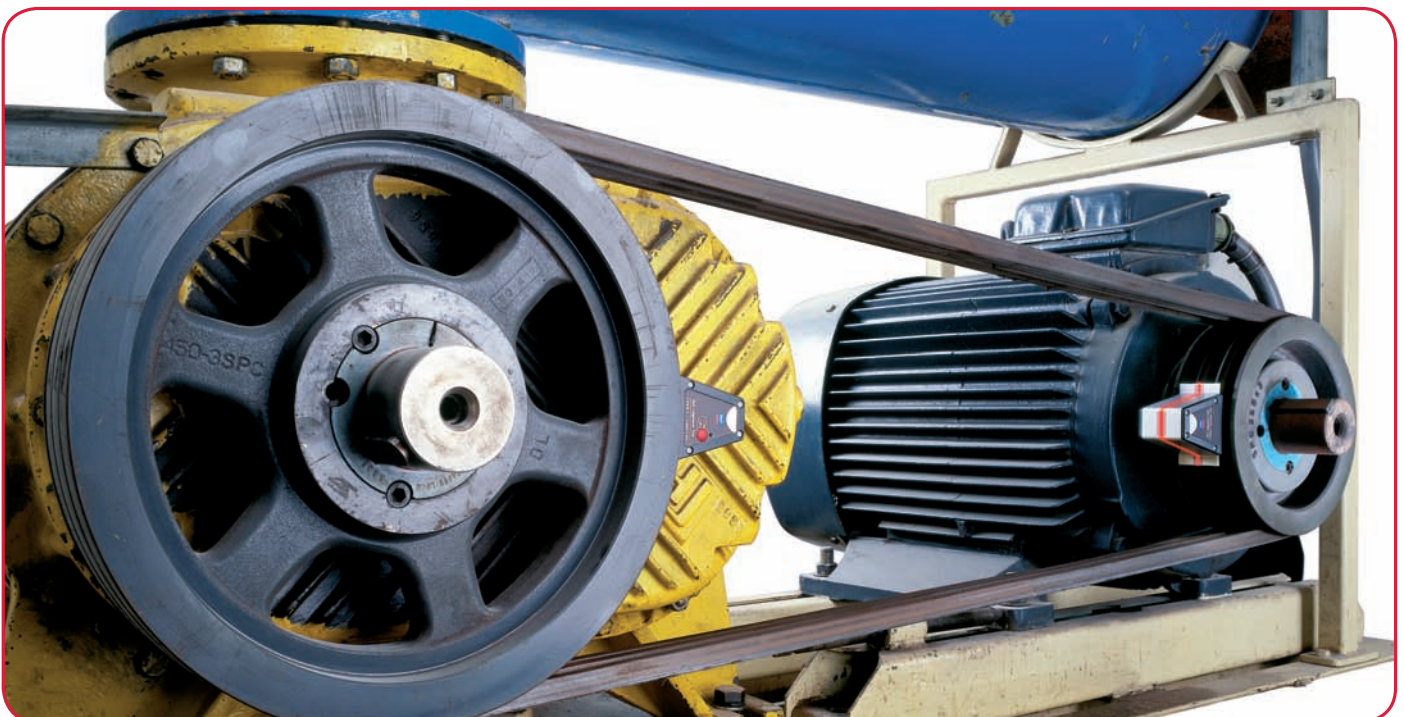

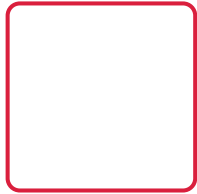

Shaft alignment tools

TMEA Series

- ▶ Belts
- ▶ Chains
- ▶ Couplings
- ▶ Bushings and Hubs
- ▶ Sprockets
- ▶ Pulleys
- ▶ Smart tools

Pinpoint accurate alignment simply achieved

The SKF Shaft alignment tools TMEA Series offer you simplicity with a high degree of accuracy. These highly innovative tools feature a three-step process for correcting alignment: Measuring, Aligning and Documenting. First, Measure the machinery's current alignment status.

- Easy-to-use, three-step process: Measure-Align-Document
- Compact, lightweight design
- Spirit levels allow easy and fast positioning of the measuring units
- Selectable mm or inch reading of measurement facilitates worldwide use
- Supplied in sturdy, lightweight carrying cases for portability
- Supplied with high precision SKF pre-cut shims for accurate alignment

Then Align the machine vertically and horizontally. Finally, Document and keep track of the alignment activities. These three simple steps allow you to easily and effectively align shafts using laser technology.



TMEA 2

Easy, quick and affordable shaft alignment

The TMEA 2 is an easy-to-use shaft alignment tool, which requires no special training to operate. The two measuring units can be easily attached to the shafts using magnetic brackets or chains. Each measuring unit emits a laser line, which is projected on the detector of the other unit.

- Display unit simultaneously provides clear 'real-time' coupling and feet values during alignment process making rechecking of the alignment unnecessary
- The laser and scale lines facilitate easy pre-alignment
- "Soft foot" feature easily guides the operator through this function
- Display unit can be held using one hand, freeing the operator to perform the alignment
- Magnetic brackets allow easy fixture of the measuring units onto the shaft
- A set of blank alignment reports to help you keep record of your alignment jobs
- Maximum distance of 0,85 m (2.8 ft) between the measuring units brackets

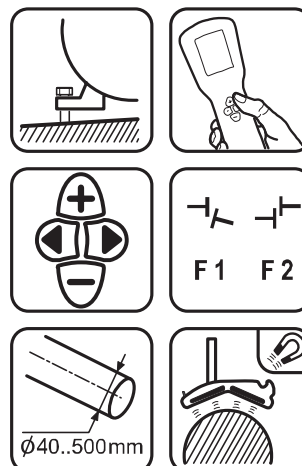



Shaft alignment tools

TMEA Series

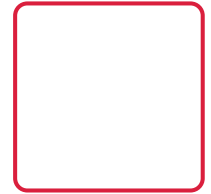

Shaft alignment tool with printer capability TMEA 1P/2,5

Record alignment activities using an optional printer

The TMEA 1P/2,5 offers you the advantage of keeping record of the alignment activities. It is equipped with a printer port to which the optional thermal printer TMEA P1 can be connected. The printer provides a clear and complete

alignment report, which can be used to document alignment activities. This user-friendly printer is operated with the touch of a single button on the display unit of the TMEA 1P/2,5.

- Optional printer facilitates recording of alignment activities
- Maximum distance of 2,5 m (8.2 ft) between the measuring units makes it suitable for aligning variety of applications
- Display unit provides clear 'real-time' values during the alignment process making rechecking alignment unnecessary
- User-friendly display unit with only four buttons for operation
- Supplied with blank alignment reports for recording alignment activities in case the printer is not purchased

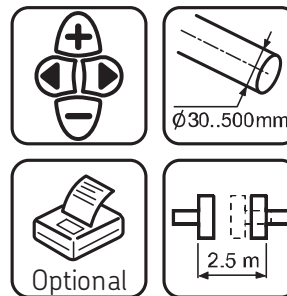

Intrinsically Safe Shaft Alignment Tool TMEA 1PEX

Accurate alignment in explosive hazardous areas

The TMEA 1PEX is an intrinsically safe (Ex) shaft alignment tool, especially designed for use in potentially explosive hazardous areas. It has been tested and certified according to the latest ATEX standards in intrinsic safety

zones generally found in industries such as the petrochemical, gas and pharmaceutical among others. The TMEA 1PEX is supplied standard with a thermal printer for recording alignment activities.

- Intrinsically safe classification ATEX code: II 2 G, EEx ib IIC T4, at ambient temperature range of 0 to 40 °C (32 to 104 °F) EC Type Examination Certificate Nemko03ATEX101X
- Standard printer facilitates recording of alignment activities
- Maximum distance of 1 m (3 ft) between the measuring units makes it suitable for aligning a variety of applications
- Display unit provides clear 'real-time' values during the alignment process making rechecking alignment unnecessary
- User-friendly display unit with only five buttons for operation

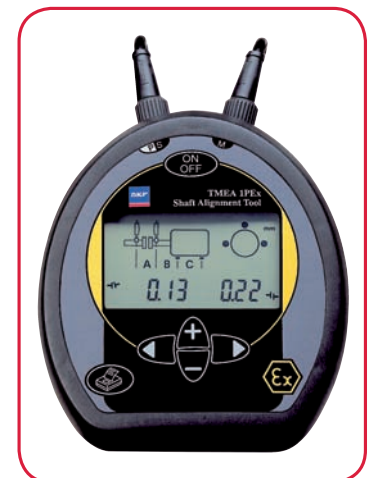
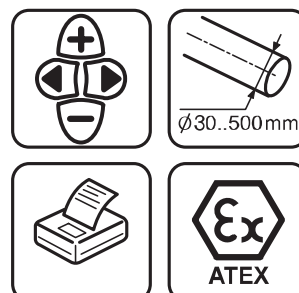

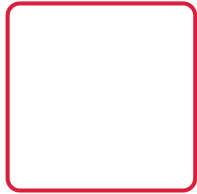

Shaft alignment tools

TMEA Series

- ▶ Belts
- ▶ Chains
- ▶ Couplings
- ▶ Bushings and Hubs
- ▶ Sprockets
- ▶ Pulleys
- ▶ Smart tools

Thermal printer TMEA 1P

Keep track of alignment jobs

This compact thermal printer helps you to document your alignment jobs. A clear and complete printout of the measurement data shows that the machine has been properly aligned within the allowed tolerances.

- Compact easy-to-use printer
- Clear easy-to-read printout
- Pre-alignment and post-alignment reports possible
- Battery is rechargeable
- Continental European adaptor included
- Printer uses standard thermal paper roll (120 mm x 20 m) / (4.4 in x 65 ft)
- Can be used in combination with TMEA 1P/2,5 and TMEA 1PEX only



Machinery Shims TMAS series

For accurate vertical machinery alignment

Accurate machine adjustment is an essential element of any alignment process. SKF single slot pre-cut shims are available in five different dimensions and in ten different thicknesses.

- Made of high quality stainless steel, allowing re-use
- Easy to fit and to remove
- Close tolerances for accurate alignment
- Thickness clearly marked on each shim
- Fully de-burred
- Pre-cut shims are supplied in packs of 10 and complete kits are also available





Shaft alignment tools

TMAS shim kits

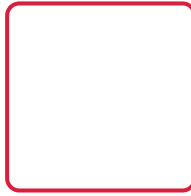

Contents TMAS Shim Kits

TMAS 340

Thickness (mm)	0.05	0.10	0.20	0.25	0.40	0.50	0.70	1.00	2.00
Size (mm)	Quantities:								
100x100	20	20	20	20	20	20	20	20	10
125x125	20	20	20	20	20	20	20	20	10

TMAS 360

Thickness (mm)	0.05	0.10	0.25	0.5	1.00	2.00
Size (mm)	Quantities:					
50x50	20	20	20	20	20	20
75x75	20	20	20	20	20	20
100x100	20	20	20	20	20	20

TMAS 510

Thickness (mm)	0.05	0.10	0.20	0.25	0.40	0.50	0.70	1.00	2.00
Size (mm)	Quantities:								
50x50	20	20	20	20	20	20	20	20	10
75x75	20	20	20	20	20	20	20	20	10
100x100	20	20	20	20	20	20	20	20	10

TMAS 720

Thickness (mm)	0.05	0.10	0.20	0.25	0.40	0.50	0.70	1.00	2.00
Size (mm)	Quantities:								
50x50	20	20	20	20	20	20	20	20	20
75x75	20	20	20	20	20	20	20	20	20
100x100	20	20	20	20	20	20	20	20	20
125x125	20	20	20	20	20	20	20	20	20



TMAS 340



TMAS 360



TMAS 510



TMAS 720

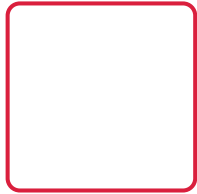

Inspection tool

Stroboscope TMRS 1

- ▶ Belts
- ▶ Chains
- ▶ Couplings
- ▶ Bushings and Hubs
- ▶ Sprockets
- ▶ Pulleys
- ▶ Smart tools

Easy, cost effective inspection in a flash

The SKF TMRS 1 is a portable, easy-to-use stroboscope that allows the motion of rotating or reciprocating machinery to appear frozen, facilitating inspection without stopping the machine. Equipped with a phase shift feature that allows the user to advance or retard the flash timing without changing the flash rate, the motion can be 'frozen' at the position required for inspection.

- The bright flash allows better illumination of the application at a distance, giving a wider viewing area.
- Flash rates of up to 12,500 flashes per minute (FPM) cover a wide range of applications
- Flash rate is quick and easy to adjust using the variable dial rate. Allowing the required speed to be reached within a matter of seconds
- Phase shift mode for optimum inspection of gears, rolls, fans, pulleys. The feature of interest can be rotated to the correct position for inspection
- x2, •2 buttons for quick adjustment of FPM
- Easy to read LCD display
- Compact design, one-hand operated instrument
- Battery powered with long running time per charge (up to 2.5 hrs)
- Includes universal AC adaptor that can be used worldwide
- Extra flashtube supplied to minimise downtime of unit
- Supplied in carrying case for protection and portability
- Mounting thread on the underside allows mounting on a tripod for stability and ease of use



Technical data

Designation	TMRS 1
Flash rate range	40-12,500 flashes per minute (FPM)
Flash rate accuracy	+/- 0.5 FPM or +/- 0.01% of reading, whichever is greater
Flash setting resolution	100 to 9999 FPM - 0.1FPM, 10,000 to 12,500 FPM -1FPM
Tachometer range	40 - 59,000 RPM
Tachometer accuracy	+/- 0.5 RPM or +/- 0.01% of reading, whichever is greater
Flash tube	Xenon, 10W, TMRS 1-BULB
Flash tube life	100 million flashes
Flash duration	9-15 sec
Light power	154 mJ per flash
Battery type	NiMH, rechargeable, removable
Battery capacity	2.6 AmpHr
Battery charge time	2-4 hours, using supplied AC adapter
Run time per charge	2.5 hours at 1600 FPM, 1.25 hours at 3200 FPM
Battery charger AC input	100-240 VAC, 50/60 Hz
Display	8 character by 2 line LCD, alphanumeric
Display update	continuous
Display resolution	100 to 9999 FPM - 0.1FPM, 10,000 to 12,500 FPM -1FPM
Time base	Crystal oscillator, 100 ppm accuracy
Controls	Power, x 2, x1/2, phase shift, external trigger
External trigger input	0-5V TTL type via stereo phono jack
EXTL. trigger to flash delay	5 sec maximum
Clock output 0-5V TTL	Type signal via stereo phono jack
Colour	Grey
Housing	Impact & oil resistant polycarbonate
Weight	650 g / 1 lb, 4 oz.
Operating temperature	10 °C to 40 °C (50 °F to 104 °F)
Storage temperature	-20 °C to 45 °C (-4 °F to 113 °F)



The knowledge

From the company that invented the selfaligning ball bearing 100 years ago, SKF has evolved into a knowledge engineering company that is able to draw on five platforms to create unique solutions for its customers. These platforms include bearings, bearing units and seals, of course, but extend to other areas including: lubricants and lubrication systems, critical for long bearing life in many applications; mechatronics that combine mechanical and electronics knowledge into systems for more effective linear motion and sensorized solutions; and a full range of services, from design and logistics support to conditioning monitoring and reliability systems. Though the scope has broadened, SKF continues to maintain the world's leadership in the design, manufacture and marketing of rolling bearings, as well as complementary products such as radial seals. SKF also holds an increasingly important position in the market for linear motion products, high-precision aerospace bearings, machine tool spindles and plant maintenance services.

The SKF Group has global ISO 14001 environmental certification. Individual divisions have been approved for quality certification in accordance with either ISO 9000 or QS 9000. With some 100 manufacturing sites worldwide and sales companies in 70 countries, SKF is a truly international corporation. In addition, our distributors and dealers in some 15 000 locations around the world, an ebusiness marketplace and a global distribution system put SKF close to customers for the supply of both products and services. In essence, SKF solutions are available wherever and whenever customers need them. Overall, the SKF brand and the corporation are stronger than ever. As the knowledge engineering company, we stand ready to serve you with worldclass product competencies, intellectual resources, and the vision to help you succeed.



© Airbus - photo: exm company, H. Goussé

Evolving by-wire technology

SKF has a unique expertise in fast-growing by-wire technology, from fly-by-wire, to drive-by-wire, to work-by-wire. SKF pioneered practical fly-by-wire technology and is a close working partner with all aerospace industry leaders. As an example, virtually all aircraft of the Airbus design use SKF by-wire systems for cockpit flight control.

SKF is also a leader in automotive by-wire technology, and has partnered with automotive engineers to develop two concept cars, which employ SKF mechatronics for steering and braking.

Further by-wire development has led SKF to produce an allelectric forklift truck, which uses mechatronics rather than hydraulics for all controls.

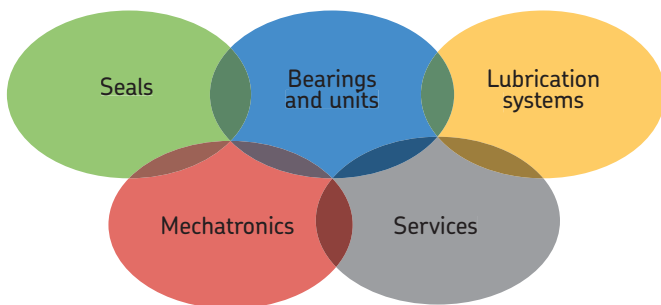

engineering company



Harnessing wind power

The growing industry of wind-generated electric power provides a source of clean, green electricity. SKF is working closely with global industry leaders to develop efficient and trouble-free turbines, providing a wide range of large, highly specialized bearings and condition monitoring systems to extend equipment life of wind farms located in even the most remote and inhospitable environments



Working in extreme environments

In frigid winters, especially in northern countries, extreme sub-zero temperatures can cause bearings in railway axleboxes to seize due to lubrication starvation. SKF created a new family of synthetic lubricants formulated to retain their lubrication viscosity even at these extreme temperatures. SKF knowledge enables manufacturers and end user customers to overcome the performance issues resulting from extreme temperatures, whether hot or cold. For example, SKF products are at work in diverse environments such as baking ovens and instant freezing in food processing plants.



Developing a cleaner cleaner

The electric motor and its bearings are the heart of many household appliances. SKF works closely with appliance manufacturers to improve their products' performance, cut costs, reduce weight, and reduce energy consumption. A recent example of this cooperation is a new generation of vacuum cleaners with substantially more suction. SKF knowledge in the area of small bearing technology is also applied to manufacturers of power tools and office equipment.



Maintaining a 350 km/h R&D lab

In addition to SKF's renowned research and development facilities in Europe and the United States, Formula One car racing provides a unique environment for SKF to push the limits of bearing technology. For over 50 years, SKF products, engineering and knowledge have helped make Scuderia Ferrari a formidable force in F1 racing. (The average racing Ferrari utilizes more than 150 SKF components.) Lessons learned here are applied to the products we provide to automakers and the aftermarket worldwide.



Delivering Asset Efficiency Optimization

Through SKF Reliability Systems, SKF provides a comprehensive range of asset efficiency products and services, from condition monitoring hardware and software to maintenance strategies, engineering assistance and machine reliability programmes. To optimize efficiency and boost productivity, some industrial facilities opt for an Integrated Maintenance Solution, in which SKF delivers all services under one fixed-fee, performance-based contract.



Planning for sustainable growth

By their very nature, bearings make a positive contribution to the natural environment, enabling machinery to operate more efficiently, consume less power, and require less lubrication. By raising the performance bar for our own products, SKF is enabling a new generation of high-efficiency products and equipment. With an eye to the future and the world we will leave to our children, the SKF Group policy on environment, health and safety, as well as the manufacturing techniques, are planned and implemented to help protect and preserve the earth's limited natural resources. We remain committed to sustainable, environmentally responsible growth.

SKF is a registered trademark of the SKF Group.

© SKF Group 2009

The contents of this catalogue are the copyright of the publisher and may not be reproduced (even extracts) unless permission is granted. Every care has been taken to ensure the accuracy of the information contained in this catalogue but no liability can be accepted for any loss or damage whether direct, indirect or consequential arising out of the use of the information contained herein.

Publication **6219 EN (VII)**

Printed in Serbia on environmentally friendly paper.