



Doosan Machine Tools

Doosan **Automotive** **Solution** **Reference**

ver. EN 210416 SU

Confidentiality:

This document is the intellectual property of Doosan Machine Tools.

Any revision, distribution or reproduction thereof is strictly prohibited unless otherwise approved by Doosan Machine Tools.

Automotive Industry

Power Train

Engine
Transmission &
Drive system

Chassis System

Steering
Suspension
Brake

Accessory & etc

Wheel
Air Conditioning
System
etc

Wealth of experience and know-how

Our vast databases, which are based on the experience and know-how accumulated by our system engineers at home and overseas over several decades, enable us to continuously provide turn-key solutions to meet our customers' requirements.

The customer comes first!

We always put our customers first by providing them with unique solutions designed to produce the best results under all conditions.

Experts at home and abroad

Thanks to its consummate professionalism and teamwork, our system solutions team responds promptly to customers' technical requirements, executes diverse projects, and operates an advanced technical infrastructure in order to provide the most efficient solutions to all our customers.

Thorough whole-process management

We provide the best full-process service, ranging from pre-order qualification to on-time delivery with continuous consideration of customer needs, and a comprehensive post-delivery service.

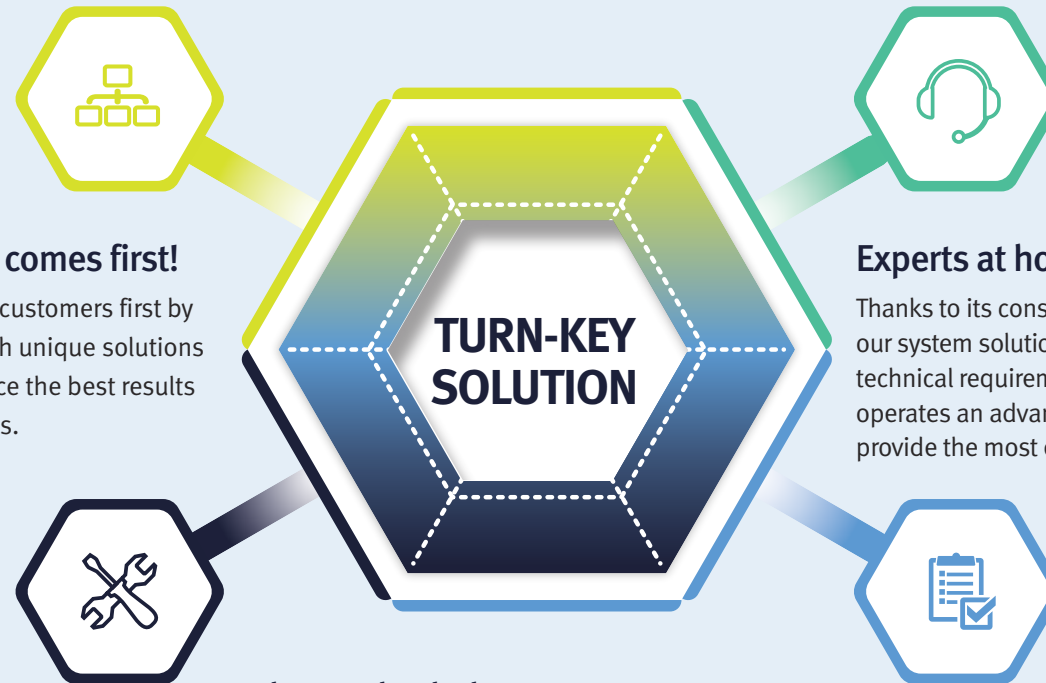

Overview of the Automotive Parts Industry

Automotive Industry

Power Train

Engine
Transmission &
Drive system

Chassis System

Steering
Suspension
Brake

Accessory & etc

Wheel
Air Conditioning
System
etc

A vehicle consists of a power train, chassis system, body, accessories, and many other parts. One single car comprises on average between 20,000 and 30,000 separate parts.

Power train_Power Generation / Transmission

A device designed to generate the power needed to move a vehicle (engine), and a device that transmits power to the driving wheels (power train)
Engine, clutch, transmission, propeller shaft, gear, axle, etc.

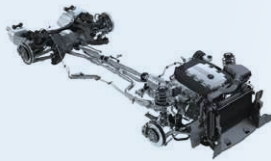

Chassis System_Steering

Travel direction control systems
Steering wheel, steering shaft, steering gear, pitman arm, drag link, tie rod, steering knuckle arm, etc.



Chassis System_Suspension

A device designed to absorb shocks generated when a tire and wheel experiences rough road conditions
Coil spring, shock absorber, suspension arm, etc.



Chassis System_Braking

A device designed to control and adjust the driving speed or to stop a vehicle's forward or backward movement.
Brake pedal, brake booster, brake drum, brake disk, brake line, master cylinder, parking brake, etc.



Doosan Application Business

Automotive Industry

Power Train

Engine
Transmission &
Drive system

Chassis System

Steering
Suspension
Brake

Accessory & etc

Wheel
Air Conditioning
System
etc

Automation Solutions

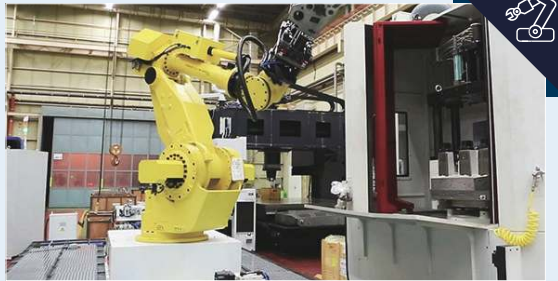

Robot Automation



Gantry Loader



LPS (Linear Pallet System)

Automation Peripherals

Bar Feeder & Stocker



Rotary Table

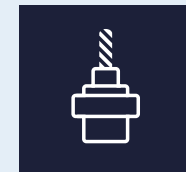
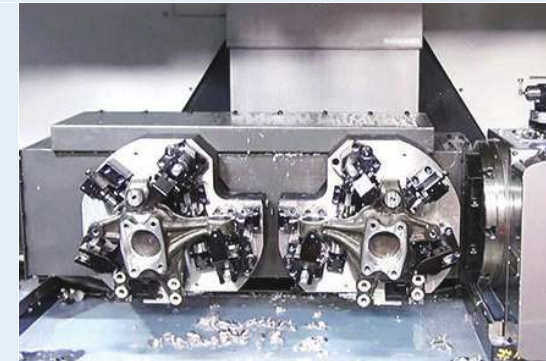

Special Chuck



Automatic Measurement System

Our Automotive Industry Customers

Automotive Industry

Power Train

Engine
Transmission &
Drive system

Chassis System

Steering
Suspension
Brake

Accessory & etc

Wheel
Air Conditioning
System
etc

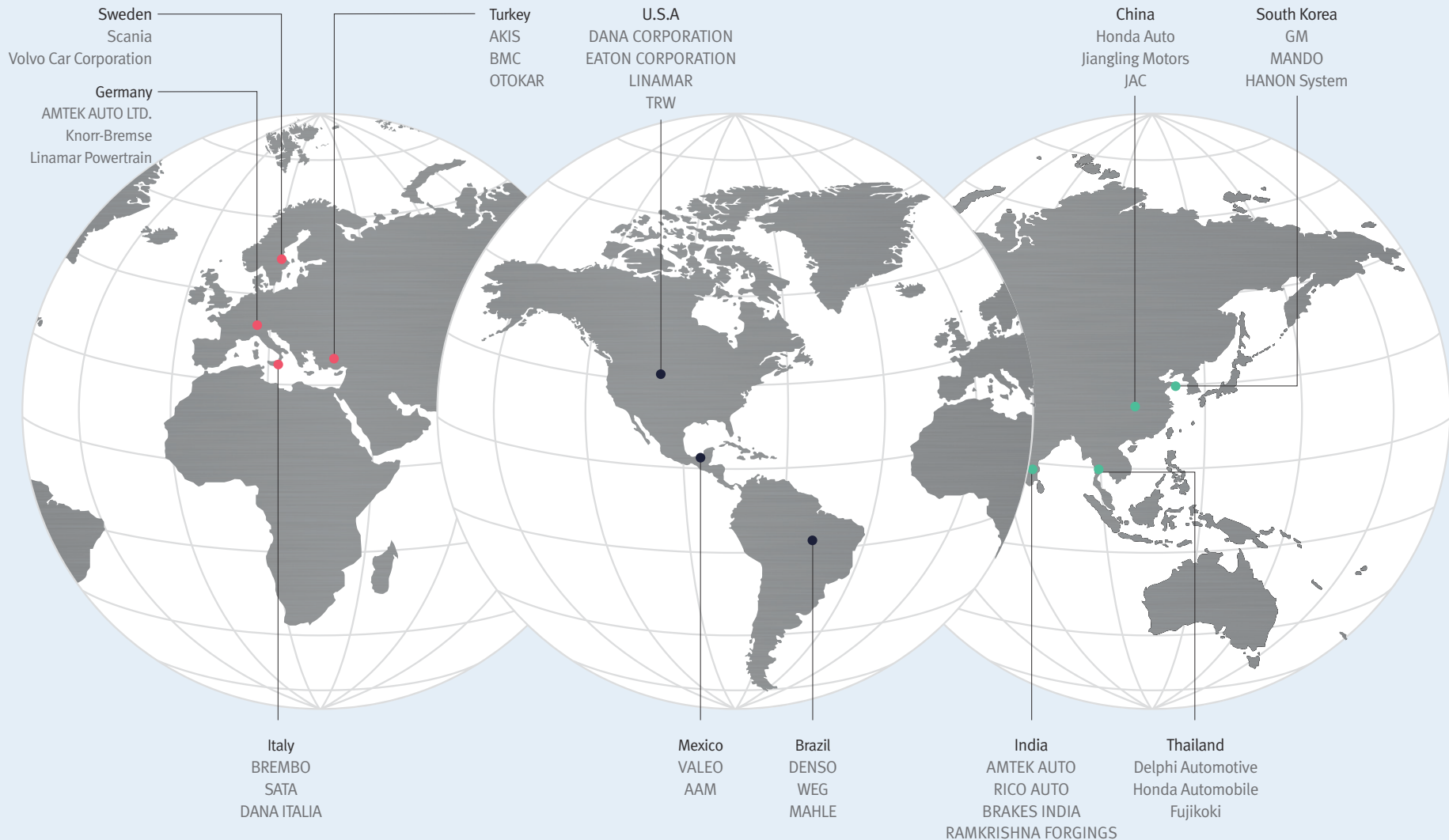

Customer Success Story

Automotive Industry

Power Train

Engine
Transmission &
Drive system

Chassis System

Steering
Suspension
Brake

Accessory & etc

Wheel
Air Conditioning
System
etc



China

Reliable customer services

"We had confidence in Doosan's machines due to their stable operation rate and durability. This is already our fourth project with Doosan. While we were conducting the system line project, Doosan shared its technology with us unreservedly, and accepted all our requirements including any additional functions we needed in connection with various regulations."

B Company (China)

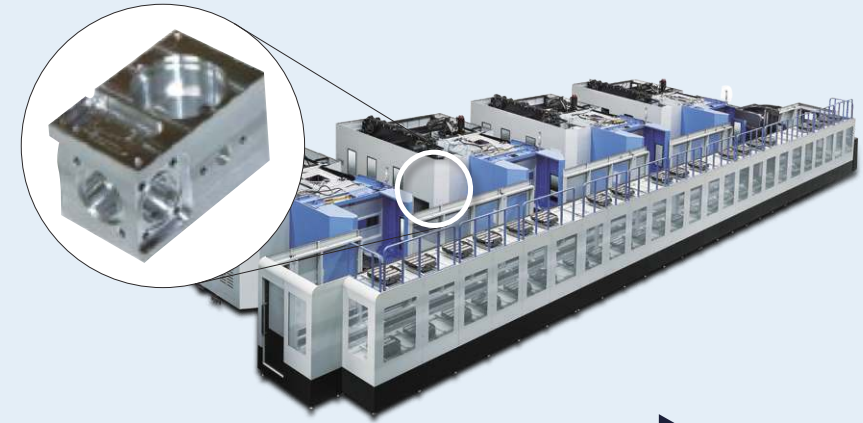

A Company (U.S.A)

Maximum efficiency with minimum workforce

"Doosan's LPS system, introduced by HYPI, is a linear pallet system designed to maximize productivity and quality with a minimum workforce. The 12-pallet LPS is suitable not only for large factories but also for small and medium-sized firms. Another great advantage is the perfect service offered by Doosan after the design, establishment and installation of the automated system. We are currently using the HP 5100 primarily because it can respond very quickly to frequent changes of workpieces."

U.S.A

Index

* Click the part's name to jump to the specific page.



Power Train

Engine

Cylinder Block
Cylinder Head
Crank Shaft
Cam Shaft
Turbine Housing
Compressor Housing
Timing Chain Cover
Pump Cover
Pulley
Piston Pin
Oil Pump Cover

Transmission & Drive system

FlyWheel
Transmission Case
Clutch Hub
Clutch Boss
Axle Housing
Outer Race
Parking Gear
Sun Gear
Diffrencial Carrier
Diffrencial Case
Diffrencial Case Cup
CV Joint
Oil Pump Housing
Oil Pump Body
Torque Convert Housing
Trunion
Ouput Shaft
Input Shaft
Ring Gear
Front Cover
Pressure Plate
Planetary Carrier
Planet Carrier

Rear Gear
Sleeve
Shaft
7DCT Gear
Gear
Inner Race
Bevel Gear
Clutch
Plate
Ball ramp
Bush Comp.
Closing Ring
Mid Sun Gear
Supt Annulus Gear
Motor Support
Oil Pump Cover

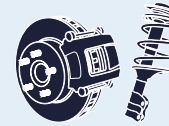

Chassis System

Steering

Rack Housing
Control Arm
Rack Bar
Ball Stud
Tie Rod
Carrier
Assist Housing
Outer Ring

Suspension

RR Carrier
Knuckle
Control Arm

Brake

Hub bearing
Hub
Caliper Carrier
Caliper Housing
Brake Disc
Master Cylinder
ABS Block
Brake Drum
Valve Seat

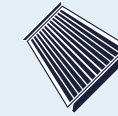

Accessory & etc

Wheel

Al Wheel
Forged Wheel
Scroll

Air Conditioning System

Rear Head
Compressor Cylinder
Pulley Clutch
Swash Plate Comp
Piston
Pulley
Pump Bracket
Ring
Rotor
Shaft for Comp.

etc

ICS Core Plate

Solution

Power Train Parts

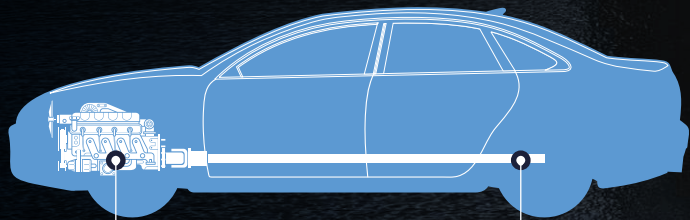

Engine

Customer E1~E10

Customer E11~E19

Customer E20~E22

Transmission & Drive

Customer T1~T10

Customer T11~T20

Customer T21~T30

Customer T31~T40

Customer T41~T50

Customer T51~T54

Customer (E1)

Automotive Industry

Power Train

Engine
Transmission &
Drive system

Chassis System

Steering
Suspension
Brake

Accessory & etc

Wheel
Air Conditioning
System
etc

Workpiece

Cylinder Block



Customer Demand

0.97min. / unit (3.88 min. /line x 4 lines)

200,000 units / year (50,000 units / year x 4lines)

1 Pallet

Solution

HC 400S, NHP series

Compact horizontal machining center, high-speed high-performance horizontal machining center

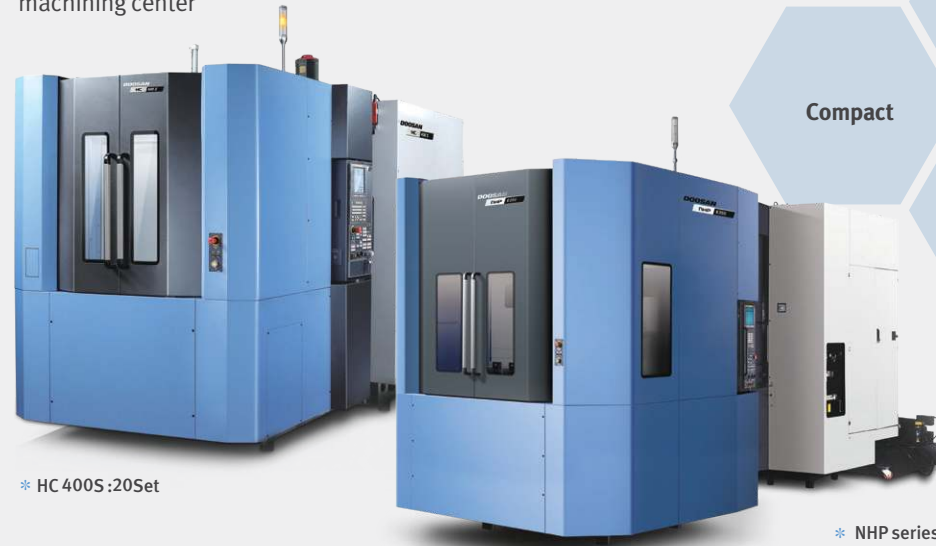

Option

- Linear Scale
- 70bar TSC
- Disk type Oil Separator

Machining Option Installation Line / Line View



Customer (E2)

Automotive Industry

Power Train

Engine
Transmission &
Drive system

Chassis System

Steering
Suspension
Brake

Accessory & etc

Wheel
Air Conditioning
System
etc

Workpiece

Cylinder Block

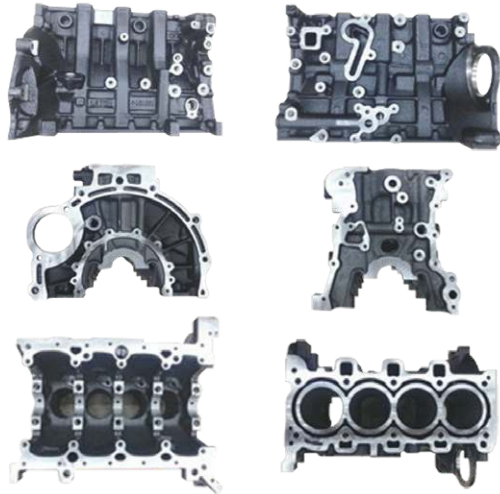

Customer Demand

200,000 units / year

58 sec. / unit

1 Pallet

Solution

NHP series

High-speed high-performance horizontal machining center



Process

- OP#10, 20** Milling, Drilling, Tapping, Reamer
- OP#30~50** Drilling, Tapping, Long Drill, Reamer, Endmill
- OP#60, 70** Measuring, Drill, Milling, Reamer, Tapping
- OP#80~100** Drilling, Tapping, Reamer, Long Drill
- OP#110** Measuring, Milling, Drill, Reamer, Notch

Option

Pump back System

1 Pallet

TSC

Machining option Installation line / Line view



Customer (E3)

Automotive Industry

Power Train

Engine

Transmission &
Drive system

Chassis System

Steering
Suspension
Brake

Accessory & etc

Wheel
Air Conditioning
System
etc

Workpiece

Cylinder Block

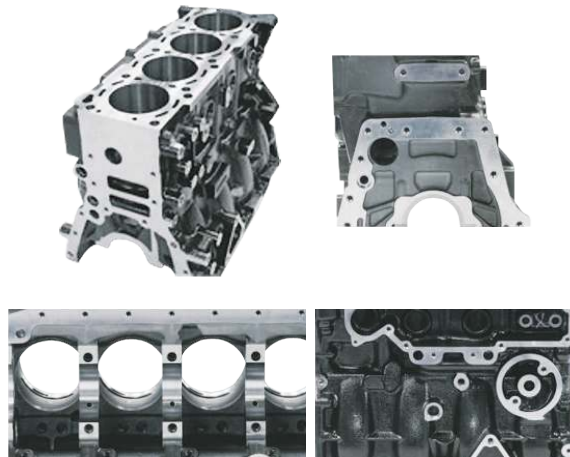

Customer Demand

200,000 units / year

58 sec. / unit

1 Pallet

Solution

NHP 5500, NHP 8000

High-Speed, High-Productivity Horizontal Machining Center



*NHP 5500 : 6set
*NHP 8000 : 5set

Process

- OP#10, 20** Top&Bottom, Intake&Exhaust - Face mill, Boring, Drill, Tap, Reamer
- OP#30** Front&Rear, Intake&Exhaust - Face mill, Drill, Tap
- OP#40** Intake&Exhaust, Bottom - Spot facing, Drill, Boring, Tap, Reamer
- OP#50, 60** Intake&Exhaust, Front&Rear - Drill, Boring, Tap

Option

HSK-100, 6000r/min

Hyd. Line for Fixture

1° Index Table

Loading Statorin Air Ports (8set)

Machining Option Installation Line / Line View



Customer (E4)

Automotive Industry

Power Train

Engine

Transmission &
Drive system

Chassis System

Steering
Suspension
Brake

Accessory & etc

Wheel
Air Conditioning
System
etc

Workpiece

Cylinder Block

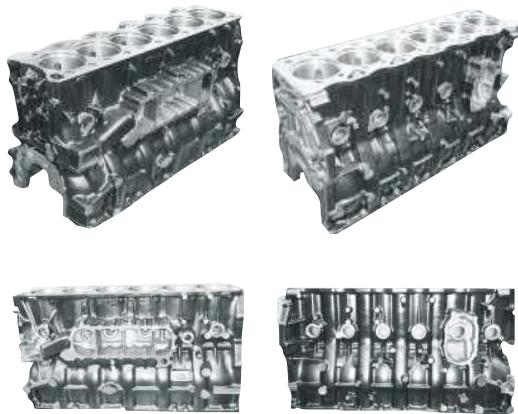

Customer Demand

10,000 units / year

23 min. / unit

Solution

NHM 8000

High-performance medium-size horizontal machining center



* 3Set

Powerful
Cutting

High Torque
1732 N·m

High-Rigidity
Structure

Process

- OP#10 Reference face, Intake face, Rear face, Front face, Exhaust face machining
- OP#20 Top face machining, Cylinder Bore machining
- OP#30 Top face, Head bolt hole (Top)

Option

OMP60

Linear Scale

Machining Option Installation Line / Line View



Customer (E5)

Automotive Industry

Power Train

Engine

Transmission &
Drive system

Chassis System

Steering
Suspension
Brake

Accessory & etc

Wheel
Air Conditioning
System
etc

Workpiece

Cylinder Head

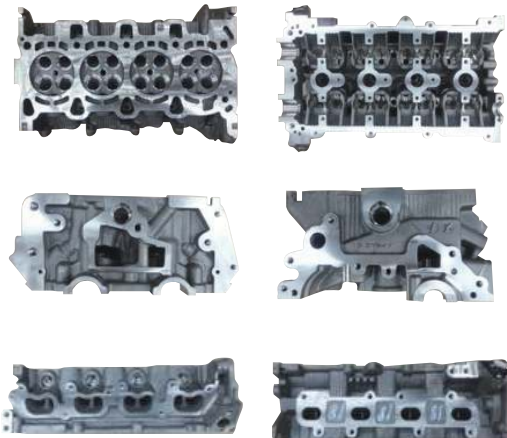

Customer Demand

200,000 units / year

58 min. / unit

1 Pallet

Solution

NHP series

High-speed high-performance horizontal machining center

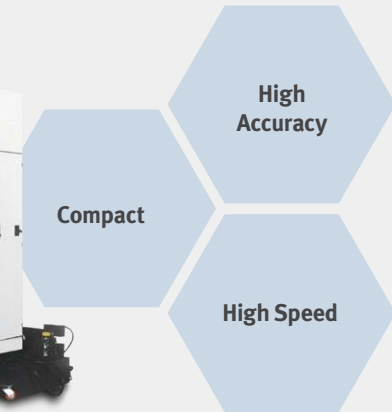

* 36Set

Process

- OP#10** Measuring, Milling, Drill, Reamer, End Mill
- OP#20** Milling, Drill, Reamer, Long Drill
- OP#30~40** Milling, Drill, Reamer, Boring, Tapping
- OP#50~70** Drilling, Tapping, Boring, Reamer
- OP#80** Drilling, End mill, Reamer, Long Drill
- OP#90** Boring, Form Tool, Milling

Option

Pump back System

1 Pallet

TSC

Machining Option Installation Line / Line View



Customer (E6)

Automotive Industry

Power Train

Engine

Transmission &
Drive system

Chassis System

Steering
Suspension
Brake

Accessory & etc

Wheel
Air Conditioning
System
etc

Workpiece

Cylinder Head

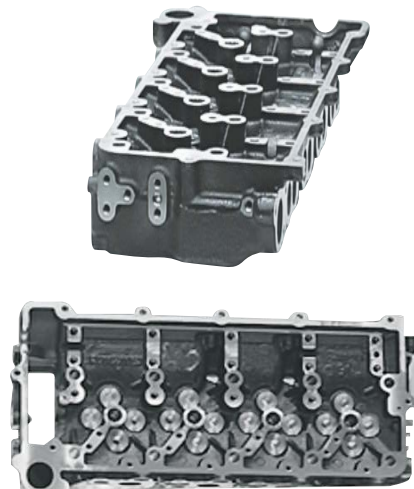

Customer Demand

250,000 units / year

4.86 min. / unit

1 Pallet

Solution

NHP 5500S, NHP 5500

High-Speed, High-Productivity Horizontal Machining Center

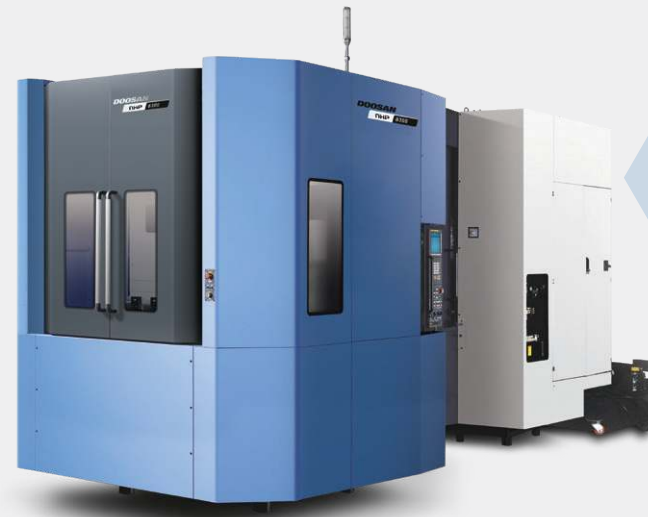

*NHP 5500S : 12set
*NHP 5500 : 2set

Process

- OP#10** Intake & Exhaust, Front&Rear - Drill, Boring, Tap
- OP#20, 30** Bottom - Face mill, Boring, Drill, Reamer, Exhaust & Intake - Face mill, Drill, Tap, Reamer
- OP#40, 50** Top - Face mill, Drill, Tap, Front & Rear - Face mill, Drill, Tap, Reamer
- OP#60** Valve seat guide rough&semi machining
- OP#100** Bottom - Face mill, Top - Finish machining, Drill, Reamer

Option

Loading Station Air Ports (8set)

Air Gap Sensing (7lines)

APC Guard Modification (w/Coolant blow)

Machining Option Installation Line / Line View



Customer (E7)

Automotive Industry

Power Train

Engine
Transmission &
Drive system

Chassis System

Steering
Suspension
Brake

Accessory & etc

Wheel
Air Conditioning
System
etc

Workpiece

Cylinder Head

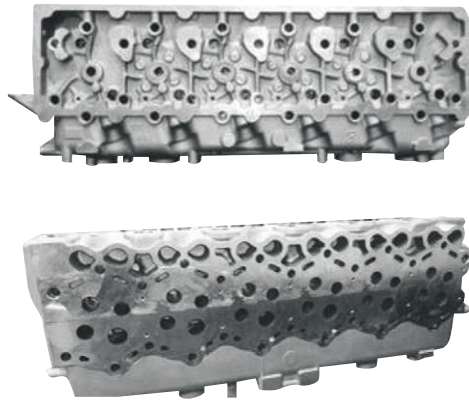

Customer Demand

10,000 units / year

23 min. / unit

Solution

NHM 8000

High-performance medium-size horizontal machining center



*3set

Powerful
Cutting

High Torque
1732 N·m

High-Rigidity
Structure

Process

- OP#10 Top face, Head bolt hole (Top)
- OP#20 Bottom face, Front and Rear face & Hole boring
- OP#30 Exhaust and Intake face & Hole boring

Option

OMP 60

Linear Scale

Machining Option Installation Line / Line View



Customer (E8)

Automotive Industry

Power Train

Engine
Transmission &
Drive system

Chassis System

Steering
Suspension
Brake

Accessory & etc

Wheel
Air Conditioning
System
etc

Workpiece

Crank Shaft



Customer Demand

14,400 units / year

8 min. / unit

Solution

VM 750L, PUMA 600

Large, high-speed / High-precision mold machining center



* VM 750L : 1set

* PUMA 600 : 1set

Process

OP#50 Grooving, O/D Lathe Rough, Finish
OP#70 Facing, Drilling, Tapping

Option

Twin Steady Rest
Rotary Table
Tool Breakage Detector

Machining Option Installation Line / Line View



Customer (E9)

Automotive Industry

Power Train

Engine
Transmission &
Drive system

Chassis System

Steering
Suspension
Brake

Accessory & etc

Wheel
Air Conditioning
System
etc

Workpiece

Crank Shaft

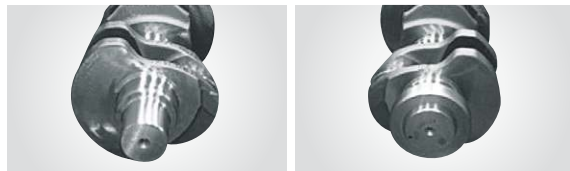
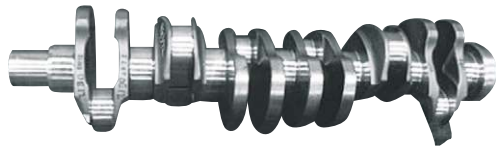

Customer Demand

250,000 units / year

8 min. / unit

Gantry Loader

Solution

NHP 6300

High-Speed, High-Productivity Horizontal Machining Center



* 1Set



Process

OP#150 Flange, Stub-end area Drill, Tap, Reamer Machining

Option

Gear Wheel Flowmeter

Prometec

Auto Workpiece Measurement

Machining Option Installation Line / Line View



Customer (E10)

Automotive Industry

Power Train

Engine

Transmission &
Drive system

Chassis System

Steering
Suspension
Brake

Accessory & etc

Wheel
Air Conditioning
System
etc

Workpiece

Cam shaft



Customer Demand

200,000 units / year

1min. 22 sec. / unit

Solution

PUMA TL2000M

High-productivity 2-turret turning center



High
Productivity

Optimized
for Shaft
Machining

2 Turrets
at Top and
Bottom

* 3Set

Process

OP#20 O.D Turning,
Grooving & Drilling

Option

KITAGAWA Chuck

V-Stand

Special Coolant Tank

Machining Option Installation Line / Line View



Customer (E11)

Automotive Industry

Power Train

Engine
Transmission &
Drive system

Chassis System

Steering
Suspension
Brake

Accessory & etc

Wheel
Air Conditioning
System
etc

Workpiece

Cam shaft



Customer Demand

172,800 units / year

1min. 30 sec. / unit

Solution

PUMA TL2000M-GL

High-productivity 2-turret turning center



High
Productivity

Optimized
for Shaft
Machining

2 Turrets at
Top and
Bottom

*2Set

Process

OP#40 Turning, Grooving, Drilling

Option

Two Hands Cycle Start Button

Reduce Tail Stock Cylinder Size

V-Stand

Machining Option Installation Line / Line View



Customer (E12)

Automotive Industry

Power Train

Engine

Transmission &
Drive system

Chassis System

Steering
Suspension
Brake

Accessory & etc

Wheel
Air Conditioning
System
etc

Workpiece

Turbine Housing



Customer Demand

60,000 units / year

5 min. / unit

Solution

PUMA V8300MR, PUMA V8300MR w/ATC

High-productivity vertical turning center, ATC + CAPTO C6



Machining
Capacity
830mm

High Torque
2592 N·m

Powerful
Cutting

*1Set

Process

OP#30 O.D Turning, I.D Turning,
Face turning & Drilling

Option

Special Tool Block (Length-Extension)

Special Chuck & Rotary Valve ASS'Y

Tool-Setter (Removable)

Machining Option Installation Line / Line View



Customer (E13)

Automotive Industry

Power Train

Engine

Transmission &
Drive system

Chassis System

Steering
Suspension
Brake

Accessory & etc

Wheel
Air Conditioning
System
etc

Workpiece

Turbine Housing



Customer Demand

20,000 units / year

7min. 10 sec. / unit

Solution

PUMA V8300MR

High-productivity vertical turning center



Machining
Capacity
830mm

High Torque
2592 N·m

Powerful
Cutting

Process

OP#30 O.D.R/F Turning, Grooving,
I.D.R/F Turning

Option

Exclusive Special Chuck & Jaw

Special I.D Tool Holder

Special work piece Measuring System

Machining Option Installation Line / Line View



Customer (E14)

Automotive Industry

Power Train

Engine

Transmission &
Drive system

Chassis System

Steering
Suspension
Brake

Accessory & etc

Wheel
Air Conditioning
System
etc

Workpiece

Compressor Housing



Customer Demand

100,000 units /year

3min. 14 sec. / unit

Solution

PUMA GT2100M, DNM 6700

Global standard turning center, Global standard vertical machining center, compact economical turning center

Powerful
Cutting

High Speed

High
Productivity



*PUMA GT2100M : 1set

*DNM 6700 :1set

Process

OP#10 Face, I.D Turning, Drilling, Tapping

OP#20 Face Milling, Drilling, Tapping,
Profile, Reamer

Option

Work Ejectore

TSA

Part Catcher

Machining Option Installation Line / Line View



Customer (E15)

Automotive Industry

Power Train

Engine

Transmission &
Drive system

Chassis System

Steering
Suspension
Brake

Accessory & etc

Wheel
Air Conditioning
System
etc

Workpiece

Timing Chain Cover

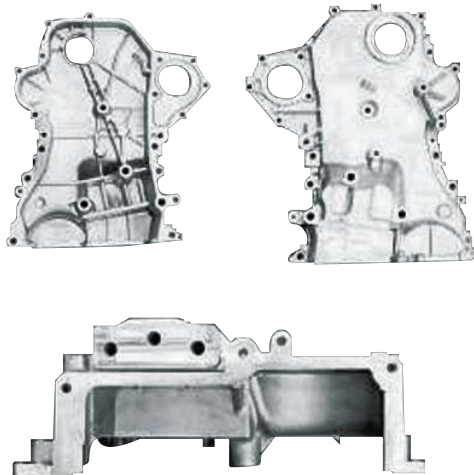

Customer Demand

120,000 units / year

OP#10 3min. 40min. OP#20 3min. 31min.

Solution

T 4000

High-speed / High-productivity tapping center

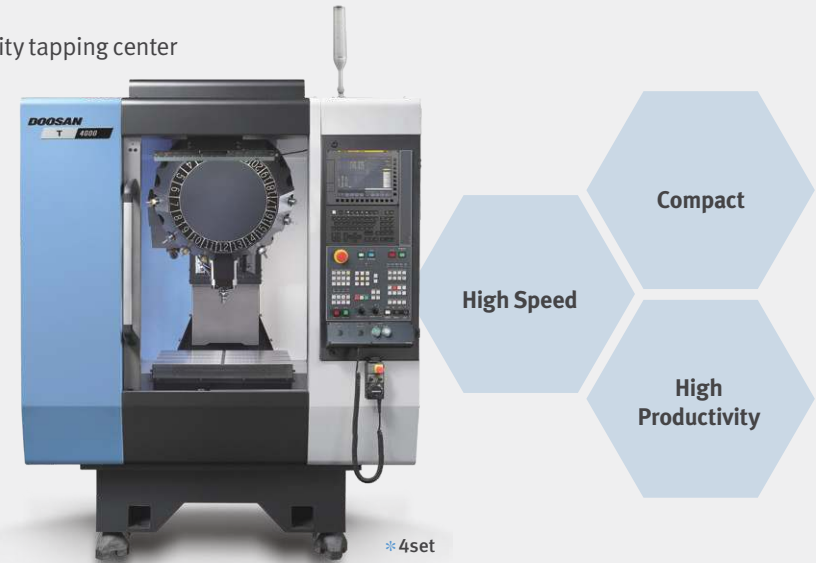

*4set

Process

OP#10 Face Milling, Drilling, Tapping,
Face Deburring

OP#20 Face Milling, Drilling, Tapping

Option

D300 NC (Made by Doosan)

Tool Broken Sensor (QWP)

Hyd. Fixture (Rotary Table – 4 Axis)

Tool & Work Count (NC option)

Machining Option Installation Line / Line View



Customer (E16)

Automotive Industry

Power Train

Engine
Transmission &
Drive system

Chassis System

Steering
Suspension
Brake

Accessory & etc

Wheel
Air Conditioning
System
etc

Workpiece

Pump Cover

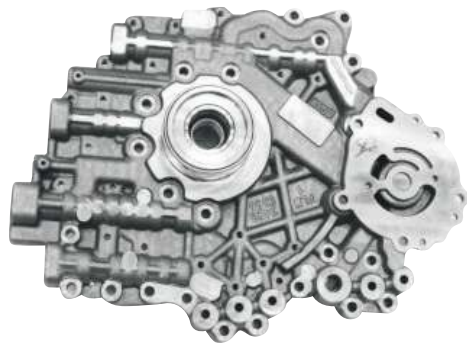

Customer Demand

20,000 units / year

30 min. / unit

Solution

PUMA V400

Compact vertical turning center

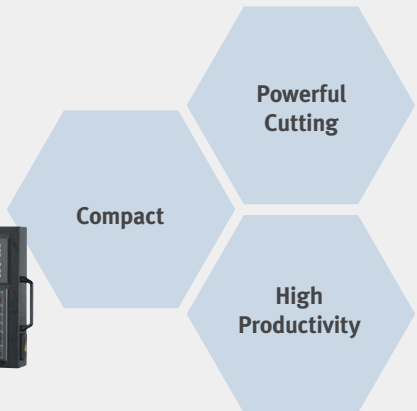

*1Set

Process

- OP#10 OD Turning Finish
- OP#20 ID Turning Finish
- OP#30 ID Turning Finish

Option

- Coolant Chiller
- TSC Pump (20 Bar)
- Chuck Clamp Confirmation
- Rotary Union
(For Special Chuck)

Machining Option Installation Line / Line View



Customer (E17)

Automotive Industry

Power Train

Engine
Transmission &
Drive system

Chassis System

Steering
Suspension
Brake

Accessory & etc

Wheel
Air Conditioning
System
etc

Workpiece

Pulley



Customer Demand

430,000 units / year

1min. 19 sec. / unit

Gantry Loader

Solution

PUMA TW2600-GL

High-productivity 2-spindle horizontal turning center



2 Spindles

High Speed
Gantry Loader

High
Productivity

* 2Set

Process

OP#20 O.D Turning, Face Grooving

OP#30 I.D Turning, O.D Grooving

Option

Mist Collector

Taco Air Sensing

Special Gripper Jaw & Pusher

Machining Option Installation Line / Line View



Customer (E18)

Automotive Industry

Power Train

Engine
Transmission &
Drive system

Chassis System

Steering
Suspension
Brake

Accessory & etc

Wheel
Air Conditioning
System
etc

Workpiece

Piston Pin



Customer Demand

600,000 units / year

1min. 9 sec. / unit

Solution

Lynx 220LS

Compact economical turning center

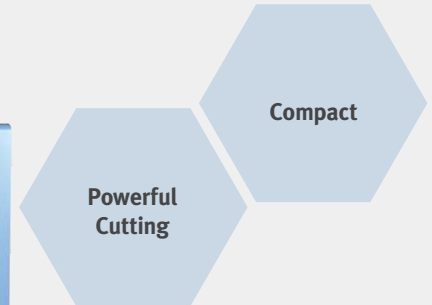

* 1Set

Process

OP#10 Turning, Drilling, Reaming

Option

Work Ejectore

TSA

Part Catcher

Machining Option Installation Line / Line View



Customer (E19)

Automotive Industry

Power Train

Engine
Transmission &
Drive system

Chassis System

Steering
Suspension
Brake

Accessory & etc

Wheel
Air Conditioning
System
etc

Workpiece

Oil Pump Cover



Customer Demand

220,000 units / year

1min. 11 sec. / unit

Gantry Loader

Solution

PUMA TW2600-GL, PUMA GT2100B

High-productivity 2-spindle horizontal turning center



* PUMA GT2100B : 1Set

* PUMATW2600-GL : 2Set

2 Spindles

High Speed
Gantry Loader

High
Productivity

Process

OP#10, 20 Cut to O.D & I.D & Face

OP#70 Cut to O.D

OP#80, 90 Cut to O.D & I.D & Face

Option

High Pressure Coolant Pump (15 bar)

Chip Conveyor (Side & Rear Scraper type)

High Speed SkipFunction

Machining Option Installation Line / Line View



Customer (E20)

Automotive Industry

Power Train

Engine
Transmission &
Drive system

Chassis System

Steering
Suspension
Brake

Accessory & etc

Wheel
Air Conditioning
System
etc

Workpiece

Compressor Housing



Customer Demand

90,000ea/year

8min 36sec/ea

Productivity

Solution

NHP 5500

High-Speed, High-Productivity Horizontal Machining Center

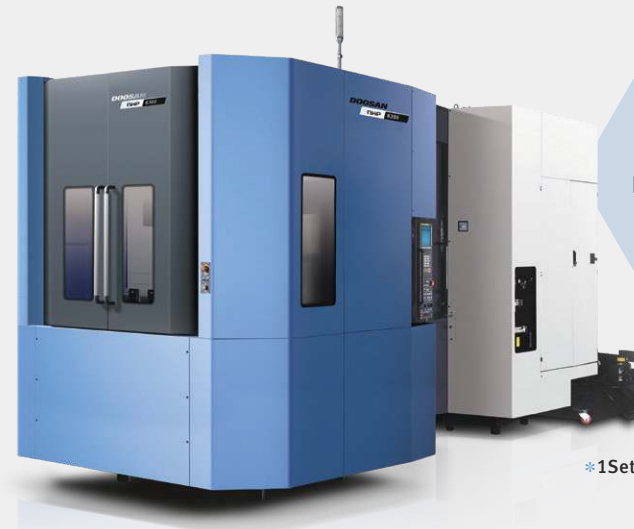

Process

OP#10 TURNING MACHINING

OP#20 MILLING & DRILLING

Option

TSC (Through Spindle Coolant)

Work Locating Confirmation(Air Sensing)

Tool Broken Unit(BK9), OMP60

Rotary Table

Machining Option Installation Line / Line View

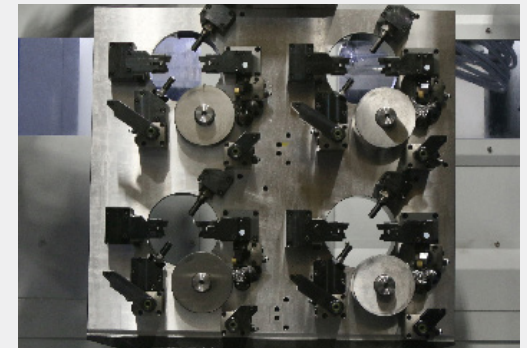

Customer (E21)

Automotive Industry

Power Train

Engine

Transmission &
Drive system

Chassis System

Steering
Suspension
Brake

Accessory & etc

Wheel
Air Conditioning
System
etc

Workpiece

Cylinder Head & Block

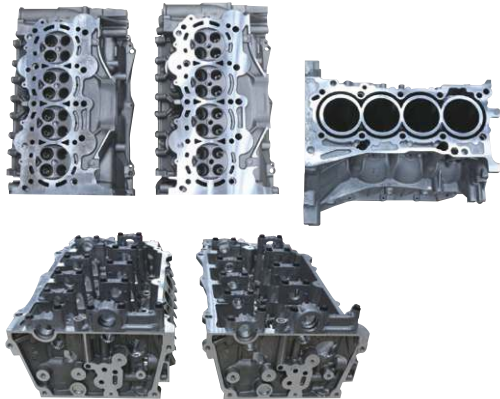

Customer Demand

200,000ea/year

HEAD : 300sec/ea, BLOCK : 90sec/ea

Robot Gantry

Solution

NHP 5500S, DNM 650/50 II, DNM 500HS

High-Speed, High-Productivity Horizontal Machining Center Global standard vertical machining center



* NHP5500S : 3Set

* DNM 650/50 II : 1Set

* DNM 500HS : 20Set

Process

- 1) CYLINDER HEAD #130(NHP5500S) :
MILLING, PILOT BORING, FINE BORING
- 2) CYLINDER BLOCK #110(DNM650/50) :
FINISH BORING, MILLING

Option

TSC (Through Spindle Coolant)

Linear Scale(X,Y,Z AXIS)

Coolant Chiller Oil Cooler for Hyd Fixture

Machining Option Installation Line / Line View



Customer (E22)

Automotive Industry

Power Train

Engine

Transmission &
Drive system

Chassis System

Steering
Suspension
Brake

Accessory & etc

Wheel
Air Conditioning
System
etc

Workpiece

Cam Shaft(6 models)

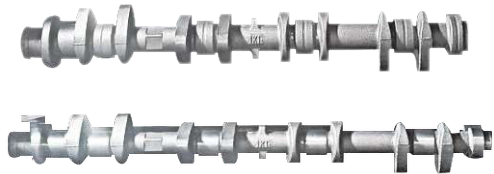

Customer Demand

240,000ea/year

92sec/ea (machining 63 sec)

Gantry Loader

Solution

PUMA TL2500

High-productivity Turning Center with Upper/lower Turrets



* 1Set



Process

OP#20 OD TURNING

Option

Work Locating Confirmation(Air Sensing)

Tool Setter

Dual Wiper

Tail Center & Tail Pokayoke(Model check)

Machining Option Installation Line / Line View



Customer (T1)

Automotive Industry

Power Train

Engine
Transmission &
Drive system

Chassis System

Steering
Suspension
Brake

Accessory & etc

Wheel
Air Conditioning
System
etc

Workpiece

Fly Wheel



Customer Demand

100,000 units / year

2min. 15 sec. / unit, 1min. 2 sec. / unit, 1min. 36 sec. / unit

Solution

PUMA V400R

Compact vertical turning center

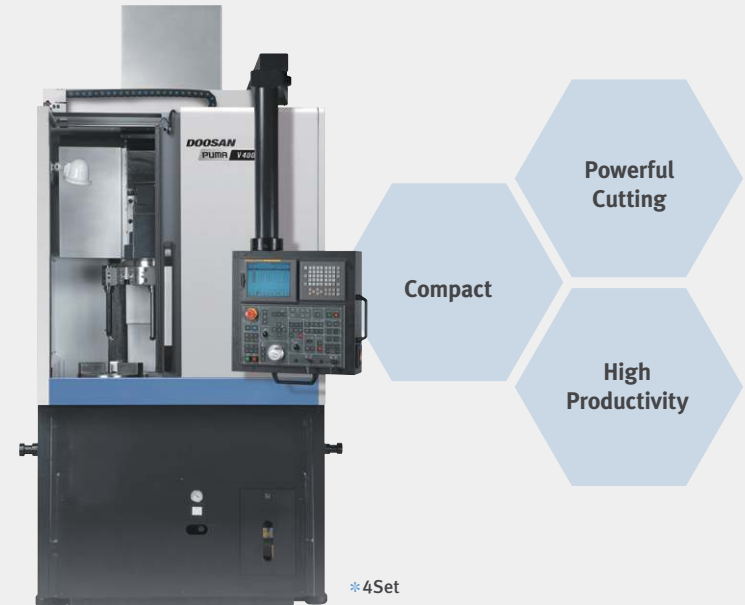

Process

- OP#10** Cutting Area: Reference Plane & Chucking Face of OP40
- OP#40** Cutting Area : Reference Plane of OP50, Finished Back Face
- OP#50** Finished Front Face

Option

Locator Air Sensing	
Wisker Switch	Buzzer Alarm

Machining Option Installation Line / Line View



Customer (T2)

Automotive Industry

Power Train

Engine
Transmission &
Drive system

Chassis System

Steering
Suspension
Brake

Accessory & etc

Wheel
Air Conditioning
System
etc

Workpiece

Fly Wheel



Customer Demand

276,500 units / year

45.9 sec. / unit

Solution

PUMA VT450-2SP, T 4000

Compact high-productivity vertical turning center, high-speed / high-productivity dual pallet tapping center



* PUMAVT450-2SP : 2Set



* T4000 : 4Set

High
Productivity

Powerful
Cutting

Compact

Process

- OP#10 OD / ID / Face Turning, ID Grooving
- OP#20 ID / Fcae Turning, ID Grooving
- OP#30 Drilling, Tapping, Reaming

Option

Air Gap Sensor

Tool Breakage Detector

Dust Collector

Machining Option Installation Line / Line View



Customer (T3)

Automotive Industry

Power Train

Engine
Transmission &
Drive system

Chassis System

Steering
Suspension
Brake

Accessory & etc

Wheel
Air Conditioning
System
etc

Workpiece

Transmission Case



Customer Demand

13,667 units / year

16.86 sec. / unit

APC

Solution

VC 510

High-productivity twin table vertical machining center



Process

OP#10 Drilling, Facing, Boring,
Chamfering

Option

Hyd. Fixture

Through Spindle Coolant

Mist Collector

Machining Option Installation Line / Line View



Customer (T4)

Automotive Industry

Power Train

Engine
Transmission &
Drive system

Chassis System

Steering
Suspension
Brake

Accessory & etc

Wheel
Air Conditioning
System
etc

Workpiece

Clutch Hub



Customer Demand

271,815 units / year

1min. 40 sec. / unit

Gantry Loader

Solution

PUMA TW2100-GL

High-productivity 2-spindle horizontal turning center



2 Spindles

High Speed
Gantry Loader

High
Productivity

Process

OP#110 O.D & I.D Groove

Option

IN, OUT Stocker

Orientation

Auto Measuring

Machining Option Installation Line / Line View



Customer (T5)

Automotive Industry

Power Train

Engine
Transmission &
Drive system

Chassis System

Steering
Suspension
Brake

Accessory & etc

Wheel
Air Conditioning
System
etc

Workpiece

Clutch Boss



Customer Demand

400,000 units / year

1min. 57 sec. / unit

Gantry Loader

Solution

PUMA TW2100-GL

High-productivity 2-spindle horizontal turning center



Process

- OP#30 O.D & I.D Rough, Finish, I.D Undercut
- OP#40 O.D Groove, I.D FACE & Finish

Option

- In Stocker
- Auto Measuring System

Machining Option Installation Line / Line View



Customer (T6)

Automotive Industry

Power Train

Engine
Transmission &
Drive system

Chassis System

Steering
Suspension
Brake

Accessory & etc

Wheel
Air Conditioning
System
etc

Workpiece

Axle Housing



Customer Demand

3,500 units / year

1hour 3min. 17 sec. / unit

Solution

NHM 6300

High-performance medium-large horizontal machining center



Process

OP#10, 20 Facing, Boring, Drilling,
Tapping, Reaming

Option

Hyd. Fixture
Linear Scale (X, Y, Z, Axis)
Through Spindle Coolant

Machining Option Installation Line / Line View



Customer (T7)

Automotive Industry

Power Train

Engine
Transmission &
Drive system

Chassis System

Steering
Suspension
Brake

Accessory & etc

Wheel
Air Conditioning
System
etc

Workpiece

Axle Housing



Customer Demand

5,800 units / year

35.5 sec. / unit

Solution

PUMA 600L

Large powerful heavy-cutting turning center



Process

OP#50 Both O.D & Face Turning

Option

Hydraulic Pre-Locator

Auto Measuring System (OLP40)

Twin Steady Rest (SLU4)

Machining Option Installation Line / Line View



Customer (T8)

Automotive Industry

Power Train

Engine
Transmission &
Drive system

Chassis System

Steering
Suspension
Brake

Accessory & etc

Wheel
Air Conditioning
System
etc

Workpiece

Outer Race



Customer Demand

500,000 units / year

28 sec. / unit

Solution

Lynx 220LMC, T 3600D

Compact economical turning center, High-speed / High-productivity tapping center



* Lynx 220LMC : 3Set

* T 3600D : 1Set

Compact

Dual Pallet

High Speed

Process

OP#20 Cut to O.D & I.D & Face

OP#30 Cut to Pin of Side

Option

MQL

Manual Tail Stock

Gantry Loader & Marposs Interface

Machining Option Installation Line / Line View



Customer (T9)

Automotive Industry

Power Train

Engine
Transmission &
Drive system

Chassis System

Steering
Suspension
Brake

Accessory & etc

Wheel
Air Conditioning
System
etc

Workpiece

Outer Race



Customer Demand

1,000,000 units / year

25 sec. / unit

Robot Automation

Solution

Lynx 220G super, PUMA GT2100M, DNM 4500

High-productivity, gang type turning center, Global standard vertical machining center, compact economical turning center, global standard vertical machining center



*Lynx 220G super : 2Set

*PUMA GT2100 : 4Set

*DNM 4500 : 4Set

Process

OP#20,30 O.D R/F Cutting & I.D R/F Cutting & Groove

OP#40 Chamfering & Key Groove Cutting

Option

Robot Interface System

2 Axis Rotary Table

Tail Stock

Machining Option Installation Line / Line View



Customer (T10)

Automotive Industry

Power Train

Engine
Transmission &
Drive system

Chassis System

Steering
Suspension
Brake

Accessory & etc

Wheel
Air Conditioning
System
etc

Workpiece

Parking Gear



Customer Demand

1min. 8 sec. / unit

Gantry Loader

Solution

PUMA TW2100-GL

High-productivity 2-spindle horizontal turning center



Process

- OP#10 O.D Rough, I.D Rough, Groove, O.D Finish, I.D Finish
- OP#20 O.D Rough, I.D Rough, O.D Finish, I.D Finish

Option

I.D Measuring System

Machining Option Installation Line / Line View



Customer (T11)

Automotive Industry

Power Train

Engine
Transmission &
Drive system

Chassis System

Steering
Suspension
Brake

Accessory & etc

Wheel
Air Conditioning
System
etc

Workpiece

Parking Gear



Customer Demand

150,000 units / year

57.6 sec. / unit

Gantry Loader

Solution

Lynx 220-GL

Compact economical turning center

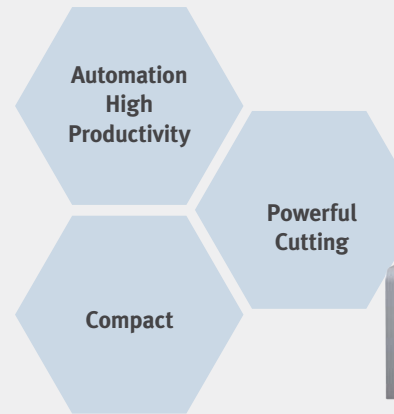

* 1Set

Process

OP#10 Item's Face Burr Removing

Option

Auto Top Door

Mist Collector

Work & Tool Counter

Machining Option Installation Line / Line View



Customer (T12)

Automotive Industry

Power Train

Engine
Transmission &
Drive system

Chassis System

Steering
Suspension
Brake

Accessory & etc

Wheel
Air Conditioning
System
etc

Workpiece

Sun Gear



Customer Demand

600,000 units / year

42 sec. / unit

Gantry Loader

Solution

Lynx 220C

Compact economical turning center

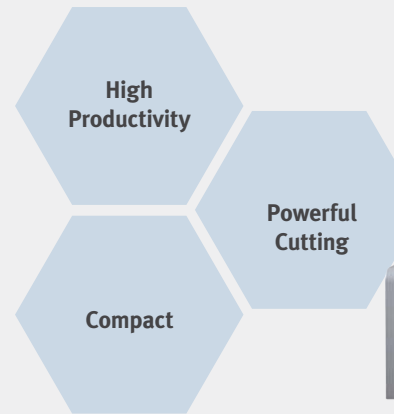

* 2Set

Process

OP#160 O.D R/FTurning & Facing

Option

Work Inspection Chute

In stocker (10-station)

Gantry Loader (3-Axis)

Machining Option Installation Line / Line View



Customer (T13)

Automotive Industry

Power Train

Engine
Transmission &
Drive system

Chassis System

Steering
Suspension
Brake

Accessory & etc

Wheel
Air Conditioning
System
etc

Workpiece

Sun Gear



Customer Demand

500,000 units / year

35 sec. / unit

Gantry Loader

Solution

PUMA TW2100-GL

High-productivity 2-spindle horizontal turning center



Process

OP#160 ID Turning

Option

Special Fixture

Special Tools

Auto Gauge

Transfer Loader

Machining Option Installation Line / Line View



Customer (T14)

Automotive Industry

Power Train

Engine
Transmission &
Drive system

Chassis System

Steering
Suspension
Brake

Accessory & etc

Wheel
Air Conditioning
System
etc

Workpiece

Differential Carrier

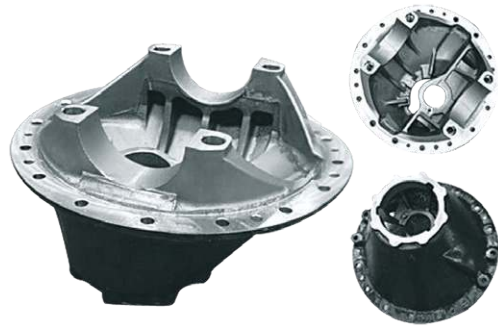

Customer Demand

330,000 units / year

30 min. / unit

Solution

Mynx 5400/50, Mynx 6500/50, NHP 6300

Powerful heavy-cutting vertical machining center



* Mynx 5400/50 : 1Set
* Mynx 6500/50 : 1Set

* NHP 6300 : 1Set

Easy Machine
Operation

Powerful
Cutting

High
Productivity

Process

OP#10 R/Cutter, Drill, Reamer, Tap
OP#20 R/Cutter, Boring, Spot Face
OP#50 F/Cutter, Boring, Drill, Tap

Option

Pokayoke System Sub Operation Box
Fixture Dual Pressure

Machining Option Installation Line / Line View



Customer (T15)

Automotive Industry

Power Train

Engine
Transmission &
Drive system

Chassis System

Steering
Suspension
Brake

Accessory & etc

Wheel
Air Conditioning
System
etc

Workpiece

Differential Carrier



Customer Demand

3min. 30 sec. / unit

Solution

PUMA V400R

Compact vertical turning center

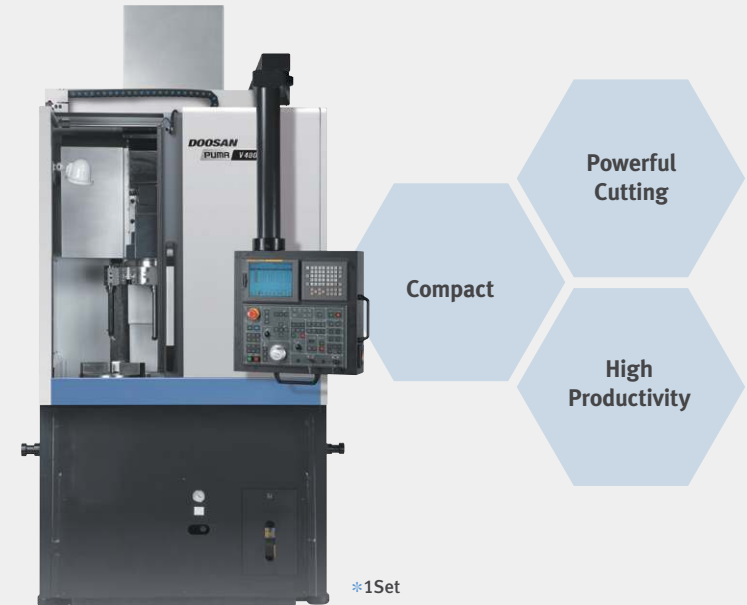

Process

OP#10 O.D Turning

Option

Pokayoke System
(Interlock Jig & Program)

Signal Tower

Level Plate (160mm)

Machining Option Installation Line / Line View



Customer (T16)

Automotive Industry

Power Train

Engine
Transmission &
Drive system

Chassis System

Steering
Suspension
Brake

Accessory & etc

Wheel
Air Conditioning
System
etc

Workpiece

Differential Case

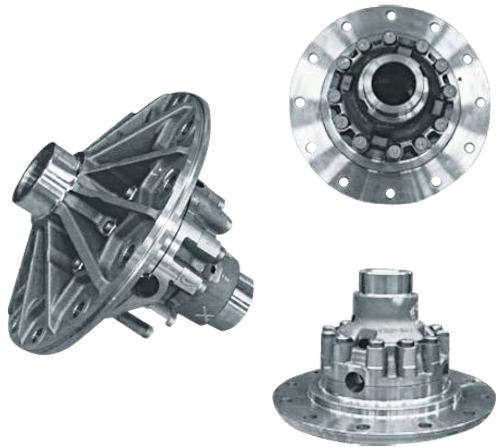

Customer Demand

51,648 units / year

1min. 2 sec. / unit

Solution

PUMA V400-2SP, PUMA V550-2SP, DNM 5700, PUMA 2600

Compact vertical turning center, global standard vertical machining center, high-performance horizontal turning center



* PUMA V400-2SP : 2Set

* PUMAV550-2SP : 2Set

* DNM 5700 : 2Set

* PUMA2600 : 1Set

Process

OP#10, 20	O.D & I.D Turning
OP#30	Drill, Reamer, Boring
OP#40	Drill, Boring
OP#50	O.D Turning

Option

20station turret
Sub Operation Box (Cycle Start, Clamp, Un clamp)
POKAYOKE System (Interlock Jig & Program)

Machining Option Installation Line / Line View



Customer (T17)

Automotive Industry

Power Train

Engine
Transmission &
Drive system

Chassis System

Steering
Suspension
Brake

Accessory & etc

Wheel
Air Conditioning
System
etc

Workpiece

Differential Case Cup



Customer Demand

120,000 units / year

10min. 44 sec. / unit

Solution

PUMA TW2100, Lynx 220C-NT, DNM 5700

High-productivity 2-spindle, horizontal turning center, compact economical turning center, global standard vertical machining center



Process

- OP#10 O.D & I.D Face Cutting
- OP#20 O.D & I.D Face, Groove Cutting
- OP#30 Hole, Tap, Reamer

Option

- Auto door, Air Limit Sensor
- 3 Head Rotary Tilting Table
- Raising Block (150mm)

Machining Option Installation Line / Line View



Customer (T18)

Automotive Industry

Power Train

Engine
Transmission &
Drive system

Chassis System

Steering
Suspension
Brake

Accessory & etc

Wheel
Air Conditioning
System
etc

Workpiece

CV Joint



Customer Demand

13,357 units / year

55 sec. / unit

Solution

PUMA 2100

High-performance horizontal turning center



* 1Set

High Accuracy

Powerful Cutting

High Productivity

Process

OP#10 O.D Turning, Facing

Option

Steady Rest

V-Stand

Machining Option Installation Line / Line View



Customer (T19)

Automotive Industry

Power Train

Engine
Transmission &
Drive system

Chassis System

Steering
Suspension
Brake

Accessory & etc

Wheel
Air Conditioning
System
etc

Workpiece

Oil Pump Housing



Customer Demand

1min. 43 sec. / unit

Gantry Loader

Solution

PUMA TW2100-GL

High-productivity 2-spindle horizontal turning center



Process

OP#10 O.D & I.D Face Turning, Drill

OP#20 O.D Face Turning,
I.D Back Turning

Option

Work Lifter

Orientation Unit

In-Stocker

Air Limit Sensor

Machining Option Installation Line / Line View



Customer (T20)

Automotive Industry

Power Train

Engine
Transmission &
Drive system

Chassis System

Steering
Suspension
Brake

Accessory & etc

Wheel
Air Conditioning
System
etc

Workpiece

Oil Pump Housing



Customer Demand

144,000 units / year

30 sec. / unit

Solution

PUMA VT450

Compact vertical turning center

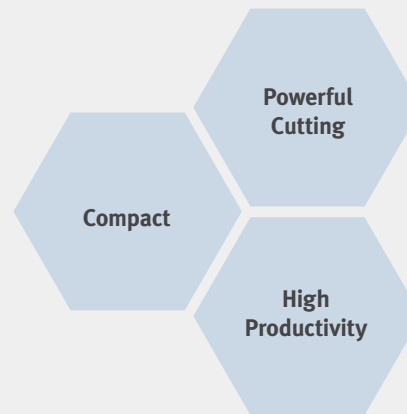

* 3Set

Process

OP#20 Facing Turning

Option

Sub Coolant Tank System

Robot Interface System

Special Level Block

Machining Option Installation Line / Line View



Customer (T21)

Automotive Industry

Power Train

Engine
Transmission &
Drive system

Chassis System

Steering
Suspension
Brake

Accessory & etc

Wheel
Air Conditioning
System
etc

Workpiece

Oil Pump Body



Customer Demand

200,000 units / year

1min. 17 sec. / unit

Gantry Loader

Solution

PUMA TW2100-GL

High-productivity 2-spindle horizontal turning center



Process

OP#10 O.D Turning, I.D Turning, O.D Grooving

OP#20 O.D Turning, I.D Turning

Machining Option Installation Line / Line View



Option

IN-Stocker (W/Work Lift & Orientation Unit)

Spindle Through Coolant

Work & Tool Counter

Customer (T22)

Automotive Industry

Power Train

Engine
Transmission &
Drive system

Chassis System

Steering
Suspension
Brake

Accessory & etc

Wheel
Air Conditioning
System
etc

Workpiece

Torque Convert Housing



Customer Demand

400,000 units / year

1min. 10 sec. / unit

Gantry Loader

Solution

PUMA TW2600-GL

High-productivity 2-spindle horizontal turning center



* 1Set

2 Spindles

High Speed
Gantry Loader

High
Productivity

Option

Add T.S.C & T.S.A

Swivel Unit of Gantry Loader
(AF46 - 95 - BP - CP - F181)

Air Sensing unit - AOL112ST3 KIT

Machining Option Installation Line / Line View



Customer (T23)

Automotive Industry

Power Train

Engine
Transmission &
Drive system

Chassis System

Steering
Suspension
Brake

Accessory & etc

Wheel
Air Conditioning
System
etc

Workpiece

Trunion



Customer Demand

640,000 units / year

35 sec. / unit

Gantry Loader

Solution

DNM 4500, Lynx 220C

Global standard vertical machining center, compact economical turning center, Compact economical turning center



Process

OP#10 Face, I.D Turning, Back Face
OP#30 O.D Turning

Option

Gantry Loader System (OP10~30)
Turn - Over & Shuttle, Conveter System (OP10~30)
Index Chuck (OP30)

Machining Option Installation Line / Line View



Customer (T24)

Automotive Industry

Power Train

Engine
Transmission &
Drive system

Chassis System

Steering
Suspension
Brake

Accessory & etc

Wheel
Air Conditioning
System
etc

Workpiece

Ouput Shaft



Customer Demand

1min. 30 sec. / unit

Solution

PUMA GT2100, T 3600D

Global standard turning center, High-speed / High-productivity tapping center



*PUMA GT2100 : 3Set

* T3600D : 1Set

High
Productivity

Dual Pallet

Powerful
Cutting

Process

- OP#10 Face / OD Rough, Center Drill, Face/OD Finish,
- OP#20 Face / OD Rough, Center Drill, Face /OD Finish
- OP#80 Grooving, Face / OD Finish, Back Turning Finish
- OP#90 Drill, Tap, End Mill

Option

- Auto. Workpiece Measurement (OMP60)
- Work & Tool Counter
- Special Dead Center

Machining Option Installation Line / Line View



Customer (T25)

Automotive Industry

Power Train

Engine
Transmission &
Drive system

Chassis System

Steering
Suspension
Brake

Accessory & etc

Wheel
Air Conditioning
System
etc

Workpiece

Input shaft



Customer Demand

2min. 29 sec. / unit

Solution

Lynx 220G

High-productivity 2-spindle horizontal turning center

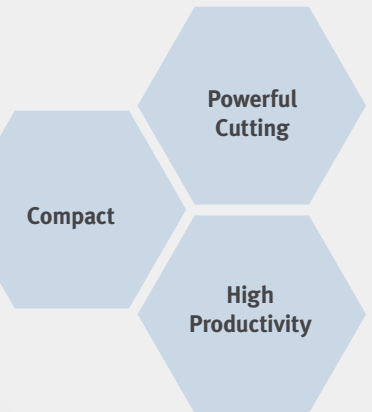

* 1Set

Process

OP#30 Guide Drill, Drill,
I.D Turning, Reamer

Option

Coolant Chiller 3kW

4-Spindle Unit

Machining Option Installation Line / Line View



Customer (T26)

Automotive Industry

Power Train

Engine
Transmission &
Drive system

Chassis System

Steering
Suspension
Brake

Accessory & etc

Wheel
Air Conditioning
System
etc

Workpiece

Ring Gear



Customer Demand

300,000 units / year

49.8 sec. / unit

Solution

Lynx 220C, T 4000

Compact economical turning center, High-speed /
High-productivity tapping center



Process

OP#10 O.D Face Turning
OP#20 Drill, Tap, Back Chamfer

Option

Air Blower for Chuck
Bed Coolant
Side Auto Door

Machining Option Installation Line / Line View



Customer (T27)

Automotive Industry

Power Train

Engine
Transmission &
Drive system

Chassis System

Steering
Suspension
Brake

Accessory & etc

Wheel
Air Conditioning
System
etc

Workpiece

Front Cover



Customer Demand

200,000 units / year

32 sec. / unit

Gantry Loader

Solution

PUMA TW2600-GL

High-productivity 2-spindle horizontal turning center



2 Spindles

High Speed
Gantry Loader

Automation
High Productivity

* 1Set

Process

OP#90 I.D Turning, Center End Mill

Option

Gantry Loader Type A3 (Both sides)

Chip Conveyor Type
(Hinged Belt_Rear Side)

Special Tool & Holder

Machining Option Installation Line / Line View



Customer (T28)

Automotive Industry

Power Train

Engine
Transmission &
Drive system

Chassis System

Steering
Suspension
Brake

Accessory & etc

Wheel
Air Conditioning
System
etc

Workpiece

Front Cover



Customer Demand

535,000 units / year

30 sec. / unit

Gantry Loader

Solution

PUMA TW2600-GL

High-productivity 2-spindle horizontal turning center



* 1Set

2 Spindles

High Speed
Gantry Loader

High
Productivity

Process

OP#70 ID Finish & Face Semi Finish

OP#80 Face Burnishing

Option

Air Part (SMC)

Name Plate (AL)

Special Oil Mist Collector

Customer (T29)

Automotive Industry

Power Train

Engine
Transmission &
Drive system

Chassis System

Steering
Suspension
Brake

Accessory & etc

Wheel
Air Conditioning
System
etc

Workpiece

Pressure Plate



Customer Demand

55 sec. / unit

Solution

PUMA VT450-2SP

Compact high-productivity vertical center



Compact

Powerful
Cutting

High
Productivity

Process

OP#10 Turning
OP#20 Turning

Option

Auto door
Dual Pressure Chucking
Air Limit Sensor

Machining Option Installation Line / Line View



Customer (T30)

Automotive Industry

Power Train

Engine
Transmission &
Drive system

Chassis System

Steering
Suspension
Brake

Accessory & etc

Wheel
Air Conditioning
System
etc

Workpiece

Pressure Plate



Customer Demand

OP#10 40 sec. / unit, OP#20 60 sec. / unit

Solution

PUMA V400R

Compact vertical turning center

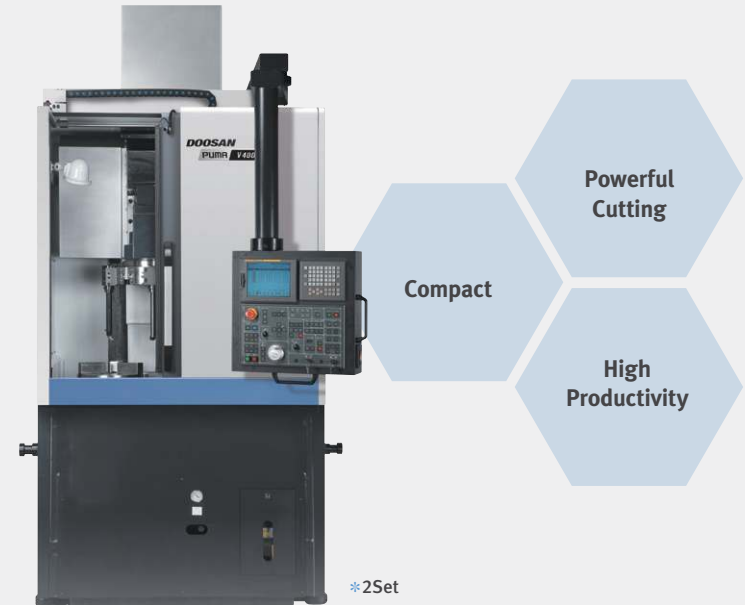

Process

- OP#10 ID, OD Turning, Face Turning
- OP#20 ID, OD Turning, Face Turning, Profiling

Machining Option Installation Line / Line View



Option

Work Support	Air Sensing Unit
Additional Hyd' Unit	Level Block

Customer (T31)

Automotive Industry

Power Train

Engine
Transmission &
Drive system

Chassis System

Steering
Suspension
Brake

Accessory & etc

Wheel
Air Conditioning
System
etc

Workpiece

Planetary Carrier



Customer Demand

150,00 units / year

57.6 sec. / unit

Gantry Loader

Solution

PUMA V550, Mynx 6500/50

High-productivity vertical turning center



* PUMA V550 : 3Set

* Mynx 6500/50 : 2Set

Process

- OP#10 O.D Rough Cutting
- OP#20 I.D Rough & Finish Cutting
- OP#30 O.D Finish Cutting
- OP#40 Drilling & Tapping

Option

- Special Chuck & Fixture
- Air Sensing, In-process Measuring
- Automation Ready

Machining Option Installation Line / Line View



Customer (T32)

Automotive Industry

Power Train

Engine
Transmission &
Drive system

Chassis System

Steering
Suspension
Brake

Accessory & etc

Wheel
Air Conditioning
System
etc

Workpiece

Planet Carrier



Customer Demand

1,500,000 units / year

31 sec. / unit

Solution

Lynx 220C-GL

Compact economical turning center

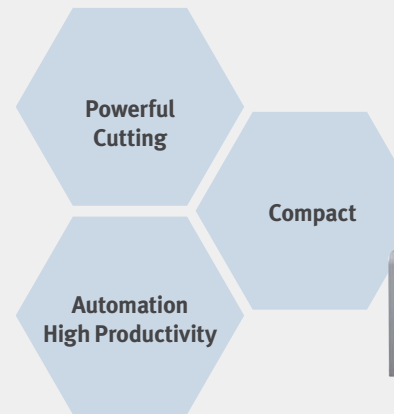

* 1Set

Process

OP#160 O.D Turning & Facing

Option

Special Chuck

In/out Stocker

Inspection Chute

Machining Option Installation Line / Line View



Customer (T33)

Automotive Industry

Power Train

Engine
Transmission &
Drive system

Chassis System

Steering
Suspension
Brake

Accessory & etc

Wheel
Air Conditioning
System
etc

Workpiece

Rear Gear



Customer Demand

60,000 units / year

1min. 4 sec. / unit

Solution

Lynx 220G

High-productivity 2-spindle horizontal turning center

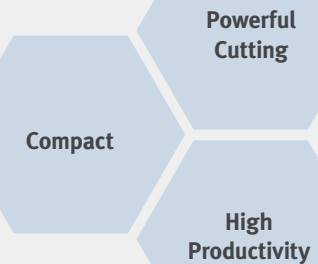

* 2Set

Process

- OP#10 Front Face Operate
- OP#20 Rear Face Operate

Option

- Work Locating Confirmation
- Soft Jaw Remove
- Chuck Clacmp Confirmation

Machining Option Installation Line / Line View



Customer (T34)

Automotive Industry

Power Train

Engine
Transmission &
Drive system

Chassis System

Steering
Suspension
Brake

Accessory & etc

Wheel
Air Conditioning
System
etc

Workpiece

Sleeve



Customer Demand

450,000 units / year

45 sec. / unit

Gantry Loader

Solution

PUMA TW2100-GL

High-productivity 2-spindle horizontal turning center



Process

- OP#10 Front Face & Groove Operate
- OP#20 Rear Groove Operate

Option

- Gantry Loaderw/Turnover
- Work Locating Confirmation
- Chuck Clamp Confirmation

Machining Option Installation Line / Line View



Customer (T35)

Automotive Industry

Power Train

Engine
Transmission &
Drive system

Chassis System

Steering
Suspension
Brake

Accessory & etc

Wheel
Air Conditioning
System
etc

Workpiece

Sleeve



Customer Demand

360,000 units / year

43 sec. / unit

Gantry Loader

Solution

PUMA TW2600-GL

High-productivity 2-spindle horizontal turning center



Process

OP#10 Face Grooving

OP#20 Burr Remove

Option

Air Blower for Chuck Add

Coolant Gun

Screw Type Chip Conveyor

Machining Option Installation Line / Line View



Customer (T36)

Automotive Industry

Power Train

Engine
Transmission &
Drive system

Chassis System

Steering
Suspension
Brake

Accessory & etc

Wheel
Air Conditioning
System
etc

Workpiece

Shaft



Customer Demand

450,000 units / year

1min. 10 sec. / unit

Gantry Loader

Solution

PUMA 2100

High-performance horizontal turning center



High Accuracy

Powerful Cutting

High Productivity

* 1Set

Process

OP#30 O.D Hard Turning, I.D Turning

Option

Gantry Loader w/Turnover

Servo Driven Tailstock

Steady Rest & TSC

Work Locating Confirmation

Machining Option Installation Line / Line View



Customer (T37)

Automotive Industry

Power Train

Engine
Transmission &
Drive system

Chassis System

Steering
Suspension
Brake

Accessory & etc

Wheel
Air Conditioning
System
etc

Workpiece

Shaft



Customer Demand

230,000 units / year

49 sec. / unit

Solution

PUMA 2100L

High-performance horizontal turning center



High Accuracy

Powerful Cutting

High Productivity

* 1Set

Process

OP#30 O.D Finish Turning

Option

Servo Driven Tailstock

Steady Rest

Work Locating Confirmation

Machining Option Installation Line / Line View



Customer (T38)

Automotive Industry

Power Train

Engine
Transmission &
Drive system

Chassis System

Steering
Suspension
Brake

Accessory & etc

Wheel
Air Conditioning
System
etc

Workpiece

7DCT Gear



Customer Demand

1,500,000 units / year

40 sec. / unit

Gantry Loader

Solution

PUMA TW2600-GL

High-productivity 2-spindle horizontal turning center



2 Spindles

High Speed
Gantry Loader

High
Productivity

Process

OP#80 I.D Turning & Facing

Option

Special In Stocker

Type Check unit

Inspection Chute

Machining Option Installation Line / Line View



Customer (T39)

Automotive Industry

Power Train

Engine
Transmission &
Drive system

Chassis System

Steering
Suspension
Brake

Accessory & etc

Wheel
Air Conditioning
System
etc

Workpiece

Gear



Customer Demand

100,000 units / year

1min. 8 sec. / unit

Gantry Loader

Solution

PUMA TW2600-GL

High-productivity 2-spindle horizontal turning center



2 Spindles

High Speed
Gantry Loader

High
Productivity

Process

OP#70 I.D & Face Turning

Option

TW2600GL- A1 Type (In, Out Stocker)

Inspection & NG Chute

Special Chuck

Machining Option Installation Line / Line View



Customer (T40)

Automotive Industry

Power Train

Engine
Transmission &
Drive system

Chassis System

Steering
Suspension
Brake

Accessory & etc

Wheel
Air Conditioning
System
etc

Workpiece

Inner Race



Customer Demand

400,000 units / year

46 sec. / unit

Gantry Loader

Solution

PUMA TW2600-GL

High-productivity 2-spindle horizontal turning center



2 Spindles

High Speed
Gantry Loader

High
Productivity

Process

OP#10 Turning & Groove

OP#20 Turning & Groove

Option

Fool Proof for Instocker Unit

Manual Q-Setter

Turn over Modification (AGREE)

Machining Option Installation Line / Line View



Customer (T41)

Automotive Industry

Power Train

Engine
Transmission &
Drive system

Chassis System

Steering
Suspension
Brake

Accessory & etc

Wheel
Air Conditioning
System
etc

Workpiece

Bevel Gear



Customer Demand

800,000 units / year

1min. 8 sec. / unit

Gantry Loader

Solution

Lynx 2100

Global compact turning center

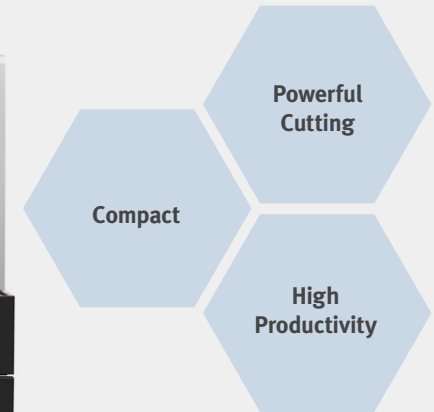

* 6Set

Process

OP#10 O.D & I.D Turning

Option

Gantry Loader Automation (Built in type)

Auto Top Door

High Productive Machine

Machining Option Installation Line / Line View



Customer (T42)

Automotive Industry

Power Train

Engine
Transmission &
Drive system

Chassis System

Steering
Suspension
Brake

Accessory & etc

Wheel
Air Conditioning
System
etc

Workpiece

Clutch



Customer Demand

300000 pcs/year

1min. 57 sec./ unit

Solution

PUMA TW2100

High-productivity 2-spindle horizontal turning center



2 Spindles

High Speed
Gantry Loader

High
Productivity

*2Set

Option

- Auto gaging
- Air blow station
- Model check station
- 1000mm Beam extension

Machining Option Installation Line / Line View



Customer (T43)

Automotive Industry

Power Train

Engine
Transmission &
Drive system

Chassis System

Steering
Suspension
Brake

Accessory & etc

Wheel
Air Conditioning
System
etc

Workpiece

Plate



Customer Demand

380000 pcs/year

1min. 27 sec./ unit

Solution

PUMA TW2600M-GL

High-productivity 2-spindle horizontal turning center



Option

- 6-Jaws Level Chuck
- Auto Work piece Measurement
- Built-in Gantry Loader
- Mist collector

Jig & Fixture

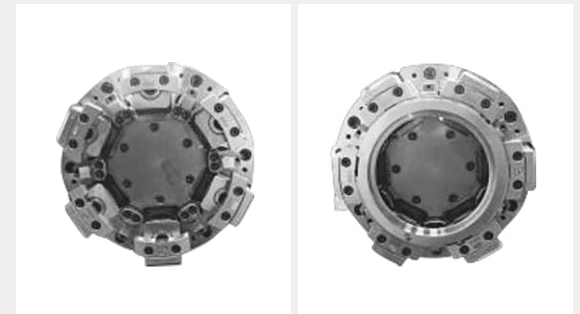

Customer (T44)

Automotive Industry

Power Train

Engine
Transmission &
Drive system

Chassis System

Steering
Suspension
Brake

Accessory & etc

Wheel
Air Conditioning
System
etc

Workpiece

Differential gear housing



Customer Demand

250,000 units/year

145sec/pc

Robot Application

Solution

PUMA V400, PUMA GT2100, DNM4500

High productivity vertical turning center / Global standard turning center /
High productivity global standard vertical machining center



Process

- OP#10 O.D/I.D Rough Turning
- OP#20 O.D/I.D Rough Turning, I.D Fine Turning
- OP#40 O.D Fine Turning
- OP#60 Drilling
- OP#80 Spherical Rough/Fine Turning

Option

- Robot Automation
- Programmable Tail Stock
- Interface for Rotary Index Table
- Coolant Level Gage

Machining Option Installation Line / Line View



Customer (T45)

Automotive Industry

Power Train

Engine
Transmission &
Drive system

Chassis System

Steering
Suspension
Brake

Accessory & etc

Wheel
Air Conditioning
System
etc

Workpiece

Input Shaft

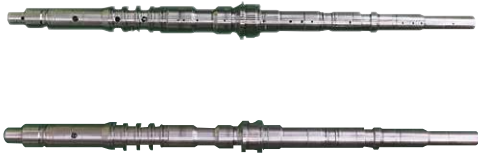

Solution

VC510, PUMA GT 2600

High-productivity twin table vertical machining center,
8"/10"/12" Global Standard Turning Center



*VC510 : 1Set

*PUMAGT2600 : 1Set

Powerful
Cutting

High
Productivity

Dual Pallet

Option

Rotary Table

OMP 60, OLP 40

Twin Steay Rest

Machining Option Installation Line / Line View



Customer (T46)

Automotive Industry

Power Train

Engine
Transmission &
Drive system

Chassis System

Steering
Suspension
Brake

Accessory & etc

Wheel
Air Conditioning
System
etc

Workpiece

Ball ramp



Customer Demand

60,000ea/year (2MODEL)

130 sec/ea

Solution

Lynx 220C , DNM4500

6"~10" High-performance Compact Turning Center,
Global standard vertical machining center



*Lynx 220C : 4Set

*DNM 4500 : 2Set

Powerful
Cutting

High
Productivity

High-Rigidity
Structure

Process

- OP#20 FACE Cutting (Before heat treatment)
- OP#50 FACE, I.D Cutting(After heat treatment)
- OP#60 Ball Cutting(After heat treatment)

Option

- Work Locating Confirmation(Air Sensing)
- TTC (Through Tool Coolant)
- TSC (Through Spindle Coolant)

Machining Option Installation Line / Line View



Customer (T47)

Automotive Industry

Power Train

Engine
Transmission &
Drive system

Chassis System

Steering
Suspension
Brake

Accessory & etc

Wheel
Air Conditioning
System
etc

Workpiece

Bush Comp.



Customer Demand

100,000ea/year

160sec/ea

Solution

Lynx 220M

6"-10" High-performance Compact Turning Center

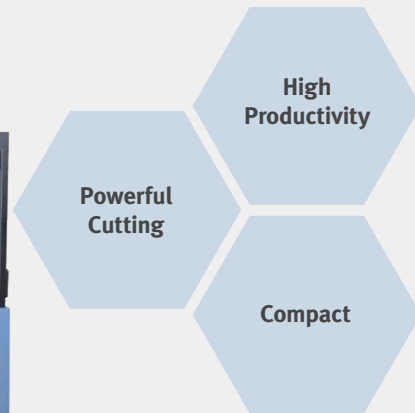

* 2Set

Option

Work Locating Confirmation(Air Sensing)

Work & Tool Counte

Mist Collectoe(0.75Kw_Water Soluble)

Ball Screw_ Net Cooling

Machining Option Installation Line / Line View



Customer (T48)

Automotive Industry

Power Train

Engine
Transmission &
Drive system

Chassis System

Steering
Suspension
Brake

Accessory & etc

Wheel
Air Conditioning
System
etc

Workpiece

Closing Ring



Customer Demand

Productivity

OP1 : 40sec/ea

OP2 : 42sec/ea

Solution

Lynx2100B

6"-10" High-performance Compact Turning Center

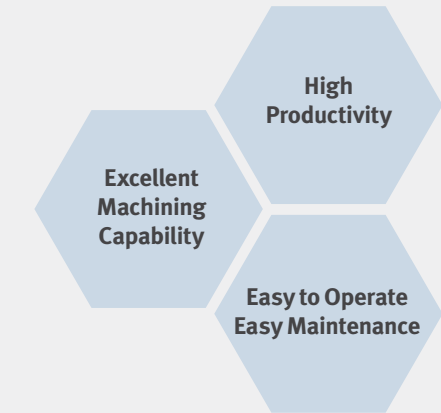

* 2set

Option

Work Locating Confirmation(Air Sensing)

Mist Collector

Machining Option Installation Line / Line View



Customer (T49)

Automotive Industry

Power Train

Engine
Transmission &
Drive system

Chassis System

Steering
Suspension
Brake

Accessory & etc

Wheel
Air Conditioning
System
etc

Workpiece

DiffCase



Customer Demand

300,000ea/year

172sec /ea

Gantry Loader

Solution

PUMA GT2100 , PUMA GT2600, DNM4500

8"/10"/12" Global Standard Turning Center, Global standard vertical machining center



*PUMA GT2100 : 1Set

*PUMA GT2600 : 2Set

*DNM 4500 : 1Set

Process

- OP#10 OD/ID ROUGH TURNING
- OP#20 OD/ID ROUGH TURNING & ID FINISH TURNING
- OP#40 OD FINISHING
- OP#60 ENDMILLING, DRILLING, CHAMFERING, REAMING

Option

- TSC (Through Spindle Coolant)
- Work Locating Confirmation(Air Sensing)
- Rotary Table(4-axis)

Machining Option Installation Line / Line View



Customer (T50)

Automotive Industry

Power Train

Engine
Transmission &
Drive system

Chassis System

Steering
Suspension
Brake

Accessory & etc

Wheel
Air Conditioning
System
etc

Workpiece

Mid Sun Gear

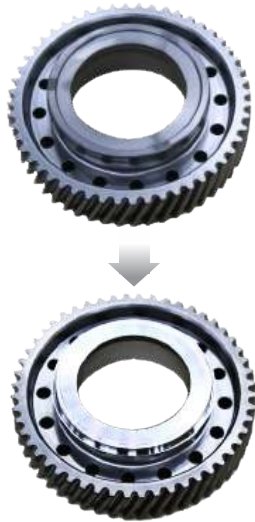

Customer Demand

600,000ea/year

30sec/ea

Gantry Loader

Solution

PUMA TW2100GL

Twin-Turret, Twin-Spindle HTC with Forward-Facing Chucks



* A3 1Set

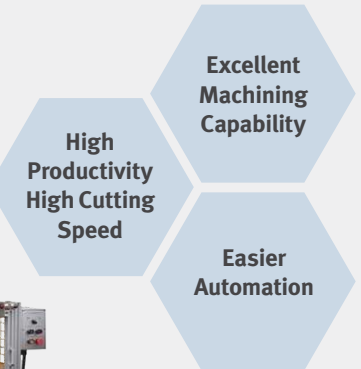

Process

OP#10 ID BACK TURNING, OD FACE TURNING

Option

Work Locating Confirmation(Air Sensing)

TSC (Through Spindle Coolant)

Measuring unit

Machining Option Installation Line / Line View



Customer (T51)

Automotive Industry

Power Train

Engine
Transmission &
Drive system

Chassis System

Steering
Suspension
Brake

Accessory & etc

Wheel
Air Conditioning
System
etc

Workpiece

Supt Annulus Gear



Customer Demand

800,000ea/year

OP1 : 33sec/ea, OP2 : 28sec/ea

Solution

Lynx 2100G

High productivity Gang type Global compact Turning center



* 4Set (OP10 : 2 Sets / OP20 : 2Sets)

Process

BEARING AUTOMATION SOLUTION

Option

Auto Quick loader (BRG Solutions)

TSA for Work unloading

Work Locating Confirmation(air Sensing)

CBS (Chip Breaking Solution)

Machining Option Installation Line / Line View



Customer (T52)

Automotive Industry

Power Train

Engine
Transmission &
Drive system

Chassis System

Steering
Suspension
Brake

Accessory & etc

Wheel
Air Conditioning
System
etc

Workpiece

Motor Support



Customer Demand

CYL1 : 125 sec/ea, CYL2 : 128 sec /ea

Solution

Lynx2100MB

6"~10" High-performance Compact Turning Center

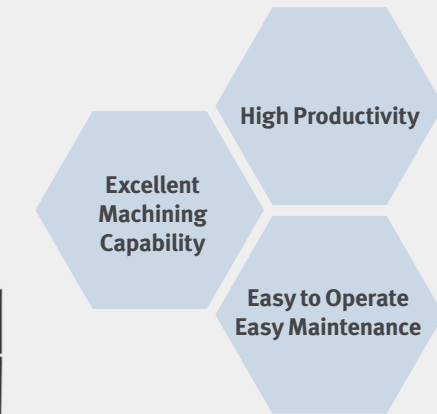

*1set

Process

OP#10 Face turn, ID turn, OD Relief turn, Drill, tap

Option

TTC (Through Tool Coolant)

TTC Filter

Coolant Chiller

Machining Option Installation Line / Line View



Customer (T53)

Automotive Industry

Power Train

Engine
Transmission &
Drive system

Chassis System

Steering
Suspension
Brake

Accessory & etc

Wheel
Air Conditioning
System
etc

Workpiece

Oil Pump Cover



Customer Demand

400,000ea/year

125sec/ea

Solution

PUMA GT2100

8"/10"/12" Global Standard Turning Center



* 1Set

Excellent
Machining
Capability

Easy to Operate

Spatial efficiency

Process

OP#80 RMP, Face turn, OD turn,
Groove turn, Relief turn

Option

Special Coolant Tank Drum Filter (3Mpa)

X-Axis Ball Screw Nut_Air Cooling

Work Offset Measuring (MARPOSS-T25)

Tail Stock Position Detection

Machining Option Installation Line / Line View



Customer (T54)

Automotive Industry

Power Train

Engine
Transmission &
Drive system

Chassis System

Steering
Suspension
Brake

Accessory & etc

Wheel
Air Conditioning
System
etc

Workpiece

Oil Pump Cover



Customer Demand

150,000ea/year

160sec/ea

Solution

PUMA GT2600B

8"/10"/12" Global Standard Turning Center



*2Set

Excellent
Machining
Capability

Easy to Operate

Spatial efficiency

Option

X-Axis Ball Screw Nut_AirCooling

OP10 : Measuring TC54-10T (BLOOM)

OP20 : Work Confirmation,

TSC (Through Spindle Coolant)

Chuck CylinderDown_SYH1246

Machining Option Installation Line / Line View



Solution

Chassis System Parts



Suspension

Customer U₁-U₃

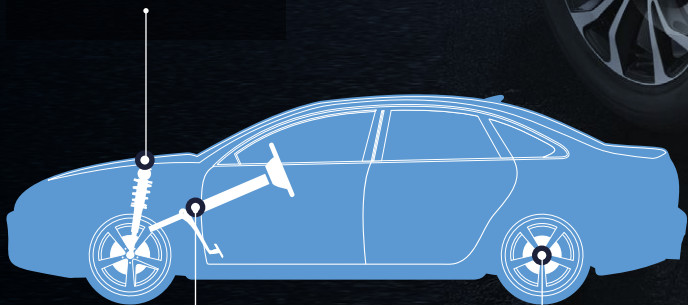

Steering

Customer S₁~5

Customer S₆~10

Brake

Customer B₁~10

Customer B₁₁~12

Customer (S1)

Automotive Industry

Power Train

Engine
Transmission &
Drive system

Chassis System

Steering
Suspension
Brake

Accessory & etc

Wheel
Air Conditioning
System
etc

Workpiece

Rack Housing



Customer Demand

16,700 units / year

7min. 29 sec. / unit

Solution

Lynx 220C, Mynx 5400, HC 400 II

Compact economical turning center, Powerful heavy-cutting vertical machining center, Compact horizontal machining center



Option

- Hyd. Fixture
- Through Spindle Coolant
- Shower Coolant

Machining Option Installation Line / Line View

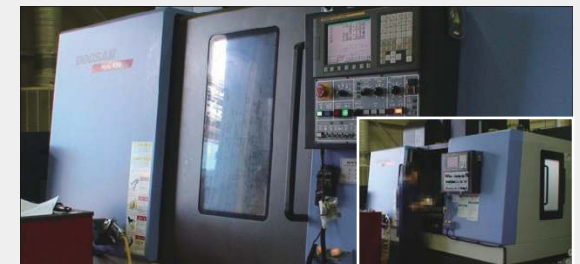

Customer (S2)

Automotive Industry

Power Train

Engine
Transmission &
Drive system

Chassis System

Steering
Suspension
Brake

Accessory & etc

Wheel
Air Conditioning
System
etc

Workpiece

Control Arm



Customer Demand

290,000 units / year

4min. 50 sec. / unit

Solution

Mynx 6500

Powerful heavy-cutting vertical machining center



*4Set



Process

OP#10 Hole Cutting

Option

Air Gap Sensor

Rotary Table

Top Door

Machining Option Installation Line / Line View



Customer (S3)

Automotive Industry

Power Train

Engine
Transmission &
Drive system

Chassis System

Steering
Suspension
Brake

Accessory & etc

Wheel
Air Conditioning
System
etc

Workpiece

Rack Bar



Customer Demand

300,000 units / year

1min. 20 sec. / unit

Bar Feeder Automation

Solution

PUMA TT1800S

High-productivity multi-function 2-turret turning center



*1Set

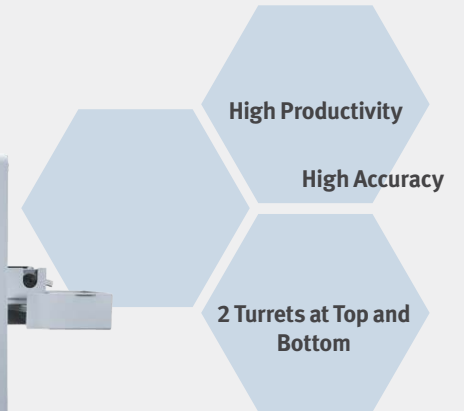

Process

OP#10 O.D Turning, Drilling, Tapping

Option

Bar Feeder & Bar Puller

Special Chuck

Air Blower for Chuck

Machining Option Installation Line / Line View



Customer (S4)

Automotive Industry

Power Train

Engine
Transmission &
Drive system

Chassis System

Steering
Suspension
Brake

Accessory & etc

Wheel
Air Conditioning
System
etc

Workpiece

Rack Bar



Customer Demand

300,000 units / year

1min. 20 sec. / unit

Bar Feeder Automation

Solution

PUMA TT1800S

High-productivity multi-function 2-turret turning center



*1Set

Process

OP#50 Both Ends of Drilling and Tapping

Machining Option Installation Line / Line View



Option

Auto Loader/unloader (Bar-Feeder System)

O.D Collet Chuck

Customer (S5)

Automotive Industry

Power Train

Engine
Transmission &
Drive system

Chassis System

Steering
Suspension
Brake

Accessory & etc

Wheel
Air Conditioning
System
etc

Workpiece

Ball Stud



Customer Demand

200,000 units / year

32 sec. / unit

Solution

Lynx 220B

Compact economical turning center

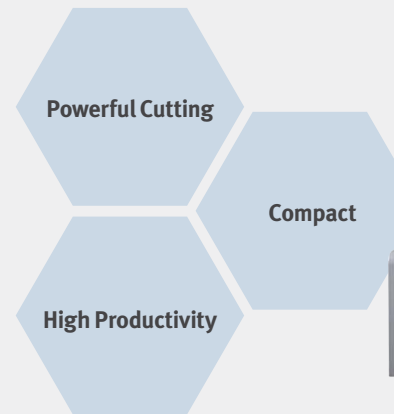

* 2Set

Process

- OP#20** O.D Turning
- OP#50** O.D Turning

Option

- Feed Back Cylinder for Work pusher
- Special Live center
- Air Cylinder for Work pusher

Machining Option Installation Line / Line View



Customer (S6)

Automotive Industry

Power Train

Engine
Transmission &
Drive system

Chassis System

Steering
Suspension
Brake

Accessory & etc

Wheel
Air Conditioning
System
etc

Workpiece

Tie Rod



Customer Demand

200,000 units / year

50, 19, 50 sec. / unit

Solution

Lynx 220B, T 4000

Compact economical turning center, High speed / High-productivity tapping center



* Lynx 220B : 4Set

Process

- OP#10 Drilling, O.D Turning, I.D Turning
- OP#20 O.D Facing
- OP#30 Facing, Drilling, Tapping

Option

Air Sensing Unit

UBL Chuck

Hydraulic Fixture

Machining Option Installation Line / Line View



Customer (S7)

Automotive Industry

Power Train

Engine
Transmission &
Drive system

Chassis System

Steering
Suspension
Brake

Accessory & etc

Wheel
Air Conditioning
System
etc

Workpiece

Carrier



Customer Demand

256,000 units / year

1min. 5 sec. / unit

Gantry Loader Automation

Solution

Mynx 6500

Powerful heavy-cutting vertical machining center



* 12Set

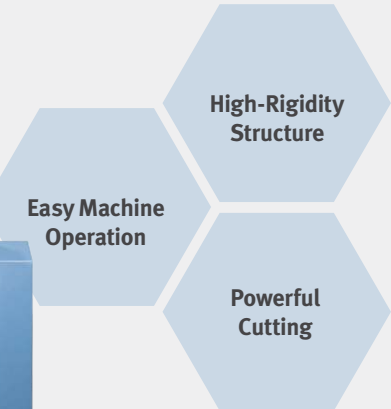

Process

- OP#10 Hub Hole & LAM Cutting
- OP#20 ABS & S AM Cutting

Option

- Gantry Loader (2-Axis)
- Rotary Table
- Top Door

Machining Option Installation Line / Line View



Customer (S8)

Automotive Industry

Power Train

Engine
Transmission &
Drive system

Chassis System

Steering
Suspension
Brake

Accessory & etc

Wheel
Air Conditioning
System
etc

Workpiece

Assist Housing



Customer Demand

55,000 units / year

6min. 8 sec. / unit

Solution

DNM 4500

High Productivity Global standard vertical machining center,
compact economical turning center

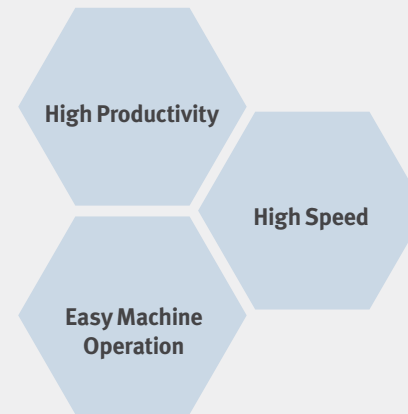

Process

OP#10 Spot Facing, Drilling, Tapping,
Hole Grooving

Option

Rotary Table (w/scale)

Auto unloading system

Special coolant system(drum)

Coolant chiller

Machining Option Installation Line / Line View



Customer (S9)

Automotive Industry

Power Train

Engine
Transmission &
Drive system

Chassis System

Steering
Suspension
Brake

Accessory & etc

Wheel
Air Conditioning
System
etc

Workpiece

Outer Ring



Customer Demand

40 sec. / unit

46 sec. / unit

Solution

PUMA TW2100-GL

High-productivity 2-spindle horizontal turning center



2 Spindles

High Speed
Gantry Loader

High
Productivity

*1Set

Option

- Air sensing
- Mist collector
- Rechucking unit
- Hinged chip conveyor

Jig & Fixture



Customer (S10)

Automotive Industry

Power Train

Engine
Transmission &
Drive system

Chassis System

Steering
Suspension
Brake

Accessory & etc

Wheel
Air Conditioning
System
etc

Workpiece

Outer Ring



Customer Demand

1min. 19 sec. / unit

Solution

PUMA TW2100-GL

High-productivity 2-spindle horizontal turning center



2 Spindles

High Speed
Gantry Loader

High
Productivity

Option

- Mist collector
- Rechucking unit
- Bed coolant separation (10bar)

Machining Option Installation Line / Line View



Customer (U1)

Automotive Industry

Power Train

Engine
Transmission &
Drive system

Chassis System

Steering
Suspension
Brake

Accessory & etc

Wheel
Air Conditioning
System
etc

Workpiece

RR Carrier



Customer Demand

240,000 units / year

58 sec. / unit

Gantry Loader

Solution

NHP 4000

High-speed high-performance horizontal machining center

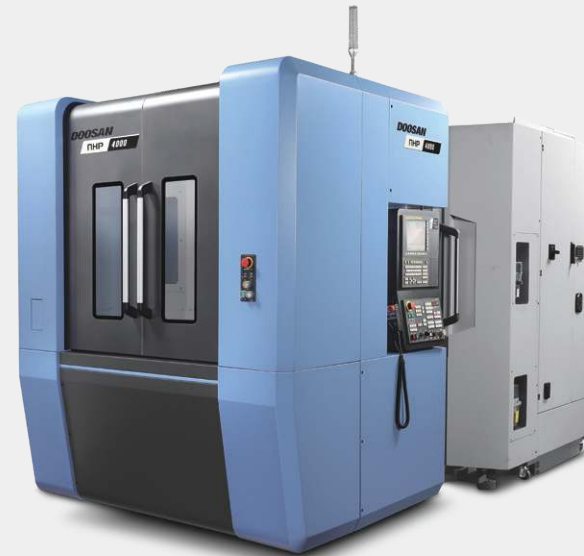

*5Set



Process

- OP#10** Milling, Drilling, Reaming
- OP#20** Milling, Spot Facing, Drilling, Reaming
- OP#30** Milling, Drilling, Tapping, Reaming
- OP#40** Milling, Drilling, Spot Facing

Option

- Mist Collector
- Gantry loader
- In/out stocker

Machining Option Installation Line / Line View



Customer (U2)

Automotive Industry

Power Train

Engine
Transmission &
Drive system

Chassis System

Steering
Suspension
Brake

Accessory & etc

Wheel
Air Conditioning
System
etc

Workpiece

Knuckle



Customer Demand

450,000 units / year

51.8 sec. / unit

Solution

NHP 5000

High-speed high-performance horizontal machining center

*22Set

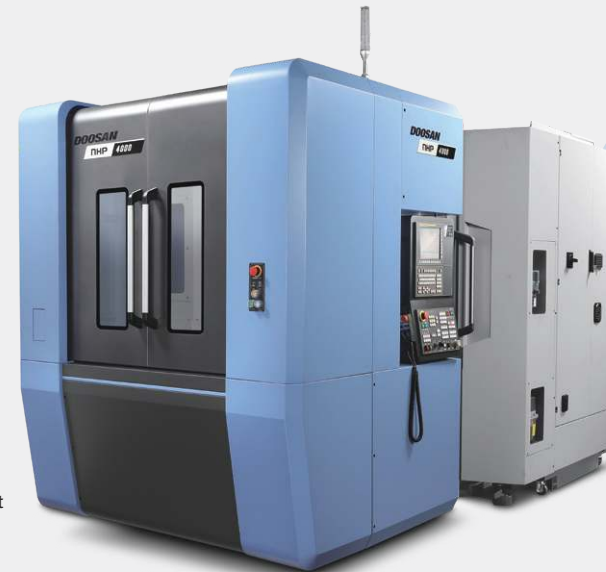

Compact

High
Productivity

High
Accuracy

Process

OP#10 Face, Bore, Caliper Ear, ABS
OP#20 Toe Link, LBJ Hole

Option

Robot Interface, HSK A63

Linear Scale X, Y, Z

Pallet Rotate at Loading Station

Air Sensing, Full B Axis(0.001°)

Customer (U3)

Automotive Industry

Power Train

Engine
Transmission &
Drive system

Chassis System

Steering
Suspension
Brake

Accessory & etc

Wheel
Air Conditioning
System
etc

Workpiece

Control Arm



Customer Demand

Tension Arm 119sec/ea

Handling Arm 119sec/ea

Gantry Loader

Solution

MYNX 6500

Powerful heavy-cutting vertical machining center



High
Productivity

Powerful

High-Rigidity
Structure

Option

Work Locating Confirmation(Air Sensing)

Tool Broken Unit (BK9)

TSC (Through Spindle Coolant)

Rotary Table(2-axis)

Machining Option Installation Line / Line View



Customer (B1)

Automotive Industry

Power Train

Engine
Transmission &
Drive system

Chassis System

Steering
Suspension
Brake

Accessory & etc

Wheel
Air Conditioning
System
etc

Workpiece

Hub Bearing



Customer Demand

250,000 units / year

1min. 9 sec. / unit

Gantry Loader

Solution

PUMA TW2600-GL

High-productivity 2-spindle horizontal turning center



2 Spindles

High Speed Gantry Loader

High Productivity

*2Set

Process

OP#10 O.D Face Turning, I.D Face Turning

OP#20 O.D Face Turning, I.D Turning

Option

Air Sen Sing (TACO)

Mist Collector

Rechucking Unit

Ng Chute & Inspection Chute

Machining Option Installation Line / Line View



Customer (B2)

Automotive Industry

Power Train

Engine
Transmission &
Drive system

Chassis System

Steering
Suspension
Brake

Accessory & etc

Wheel
Air Conditioning
System
etc

Workpiece

Hub



Customer Demand

300,000 units / year

1 min. / unit

Gantry Loader

Solution

PUMA TW2600-GL, T 3600D

High-productivity 2-spindle horizontal turning center, High speed/
High-productivity tapping center



*PUMA TW2600-GL : 2Set



*T 3600D : 3Set

Process

- OP#10/20 Hard Turning
- OP#30 Spot Facing, Drilling, Boring, Chamfering
- OP#40 Spot Facing, Chamfering

Option

- Full Automation Line (Gantry Loader)
- Air Gap Sensing
- In Conveyor, Side Conveyor with Turn Over

Machining Option Installation Line / Line View



Customer (B3)

Automotive Industry

Power Train

Engine
Transmission &
Drive system

Chassis System

Steering
Suspension
Brake

Accessory & etc

Wheel
Air Conditioning
System
etc

Workpiece

Hub



Customer Demand

400,000 units /year

OP#10, 20 : 38 min., OP30 : 50 min.

Gantry Loader

Solution

PUMA TW2600-GL, Lynx 220C

High-productivity 2-spindle horizontal turning center, Compact economical turning center



Process

OP#10 Shaft O.D / I.D Finish Turning_Hard Turning

OP#20 Bearing I.D Finish Turning_Hard Turning

Option

Mist Collector

Twin Gantry loader

Screw Type Chip Conveyor

Work Check Unit, Instocker, Transfer

Machining Option Installation Line / Line View



Customer (B4)

Automotive Industry

Power Train

Engine
Transmission &
Drive system

Chassis System

Steering
Suspension
Brake

Accessory & etc

Wheel
Air Conditioning
System
etc

Workpiece

Hub



Customer Demand

150,000 units / year

2min. 30 sec. / unit

Solution

PUMA GT2100B

Global standard turning center



Process

- OP#10 O.D Rough Turning,
I.D Rough Boring
- OP#20 O.D Finish Turning,
I.D Finish Turning

Option

- Tailstock Delete
- Mist Collector
- Interface for Automation

Machining Option Installation Line / Line View



Customer (B5)

Automotive Industry

Power Train

Engine
Transmission &
Drive system

Chassis System

Steering
Suspension
Brake

Accessory & etc

Wheel
Air Conditioning
System
etc

Workpiece

Caliper Carrier



Customer Demand

500,000 units /year

20 sec. / unit

Solution

VC 430

High-productivity twin table vertical machining center

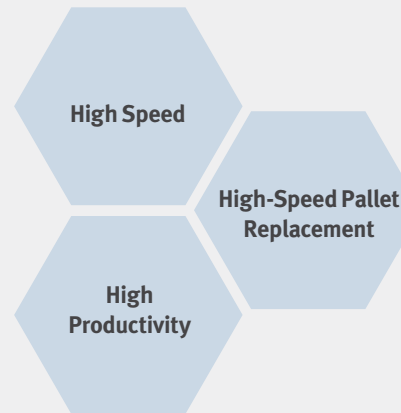

Process

OP#30 Face Milling

Option

Special Coolant Tank

2 Step Tool Brocken

Setup Shower Coolant

Machining Option Installation Line / Line View



Customer (B6)

Automotive Industry

Power Train

Engine
Transmission &
Drive system

Chassis System

Steering
Suspension
Brake

Accessory & etc

Wheel
Air Conditioning
System
etc

Workpiece

Caliper Housing

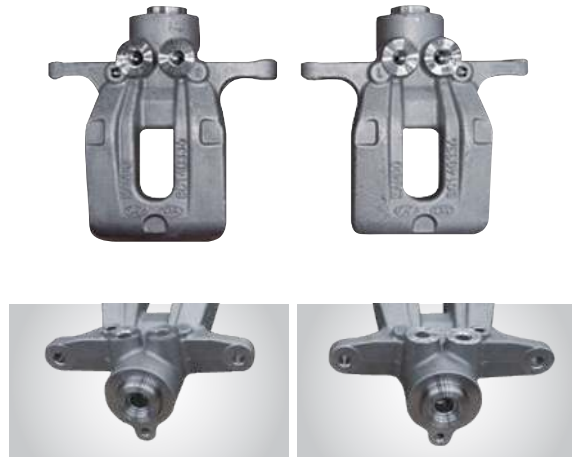

Customer Demand

300,000 units / year

24 sec. / unit

Solution

VC 430

High-productivity twin table vertical machining center

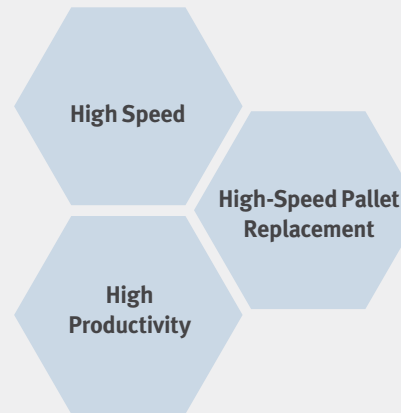

Process

- OP#40 Port Drill & Tap
- OP#50 Motor Guide Drill & Tap

Option

- Special chip Conveyor & Drum Filter Coolant Tank
- Machine Self Check System
- Special Hyd. Tank for Machine & Fixture

Machining Option Installation Line / Line View



Customer (B7)

Automotive Industry

Power Train

Engine
Transmission &
Drive system

Chassis System

Steering
Suspension
Brake

Accessory & etc

Wheel
Air Conditioning
System
etc

Workpiece

Brake Disc



Customer Demand

69,000 units / year

6min. 15 sec. / unit

Solution

PUMA VT900M, DNM 6700

Medium-large powerful cutting vertical turning center, Global standard vertical machining center, compact economical turning center



*PUMA VT900M : 2Set

*DNM 6700 : 1Set

Process

OP#10 OD, ID & Face Turning

OP#20 OD, ID & Face Turning

Option

Rotary Table + Scroll Chuck

Tool Breakage Detection

TSC (Through Spindle Coolant)

Machining Option Installation Line / Line View



Customer (B8)

Automotive Industry

Power Train

Engine
Transmission &
Drive system

Chassis System

Steering
Suspension
Brake

Accessory & etc

Wheel
Air Conditioning
System
etc

Workpiece

Master Cylinder



Customer Demand

200,000 units / year

3 min. / unit

Solution

T 3600D

High speed / High-speed / high-productivity dual pallet tapping center

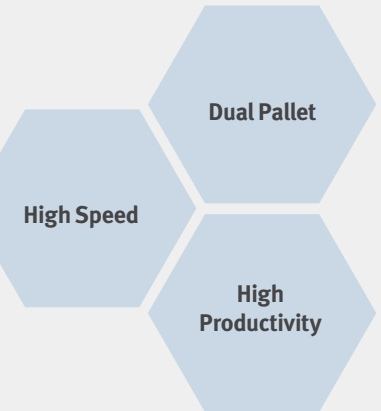

*2Set

Process

OP#20 Drill, Tap, Deburring

Option

Auto Door

Linear Scale (X- Axis)

Coolant Level Switch

Machining Option Installation Line / Line View



Customer (B9)

Automotive Industry

Power Train

Engine
Transmission &
Drive system

Chassis System

Steering
Suspension
Brake

Accessory & etc

Wheel
Air Conditioning
System
etc

Workpiece

ABS Block



Customer Demand

1,500,000 units / year

6min. 35 sec. / unit

Solution

HP 4000 II

High-speed high-performance horizontal machining center



Process

OP#20 Drill, Tap, Deburring

Option

Hyd. Unit (150bar)

Tool Breakage Detector (External)

Lubrication System (Air Mixing Valve)

Machining Option Installation Line / Line View



Customer (B10)

Automotive Industry

Power Train

Engine
Transmission &
Drive system

Chassis System

Steering
Suspension
Brake

Accessory & etc

Wheel
Air Conditioning
System
etc

Workpiece

Brake Drum



Customer Demand

237,710 units /year

1min. 29 sec. / unit

Solution

PUMA VT450, T 3600D

Compact vertical turning center, High speed / High-productivity dual pallet tapping center



*PUMA VT450 : 6Set

* T 3600D : 1Set

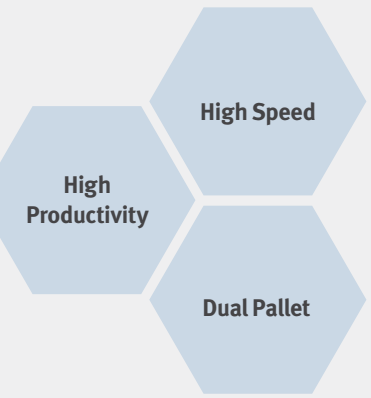

Process

- OP#10 OD, ID & Face Turning
- OP#20 OD, ID & Face Turning
- OP#50 Drilling, Tapping, Chamfering

Option

- Dual Chucking Pressure
- Hyd. Fixture
- Air Gap Sensor

Machining Option Installation Line / Line View



Customer (B11)

Automotive Industry

Power Train

Engine
Transmission &
Drive system

Chassis System

Steering
Suspension
Brake

Accessory & etc

Wheel
Air Conditioning
System
etc

Workpiece

Caliper Housing

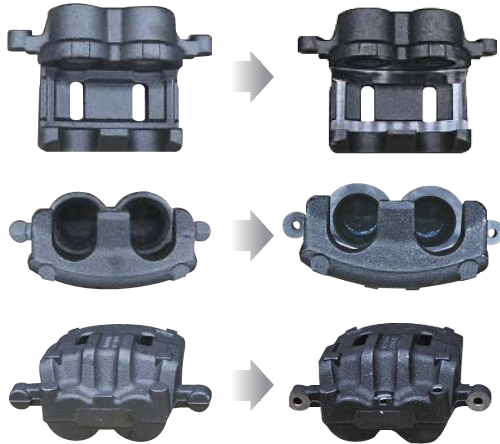

Customer Demand

20,000ea/year

253sec/ea

Solution

Mynx6500/50

Powerful heavy-cutting vertical machining center

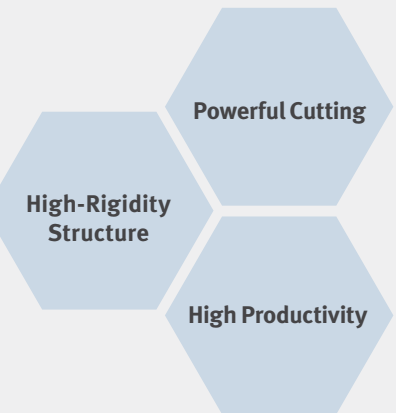

*8Set

Process

- OP#10 MILLING & DRILLING
- OP#20 MILLING & DRILLING

Option

- Work Locating Confirmation(Air Sensing)
- Rotary Table
- TSC (Through Spindle Coolant)

Machining Option Installation Line / Line View



Customer (B12)

Automotive Industry

Power Train

Engine
Transmission &
Drive system

Chassis System

Steering
Suspension
Brake

Accessory & etc

Wheel
Air Conditioning
System
etc

Workpiece

Valve Seat (ABS Block Part)



Customer Demand

50sec/ea (Cutting 42”+ Load/unloading 8”)

Productivity

Solution

PUMA TW2100_GL

Twin-Turret, Twin-Spindle HTC with Forward-Facing Chucks



* A2 1Set

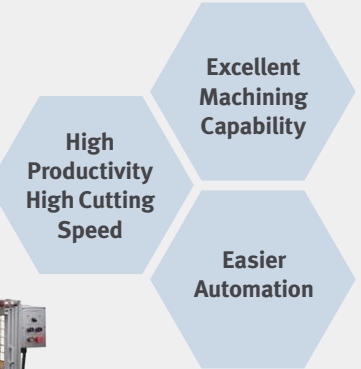

Option

In : Bowl + Linear Feeder

Out : Chute

Coolant Chiller

Work Locating Confirmation(Air Sensing)

Machining Option Installation Line / Line View



Solution Accessory & etc Parts

Air Conditioning System

*Customer C1~5
Customer C6~11*

Wheel

*Customer W1~5
Customer W6~7*

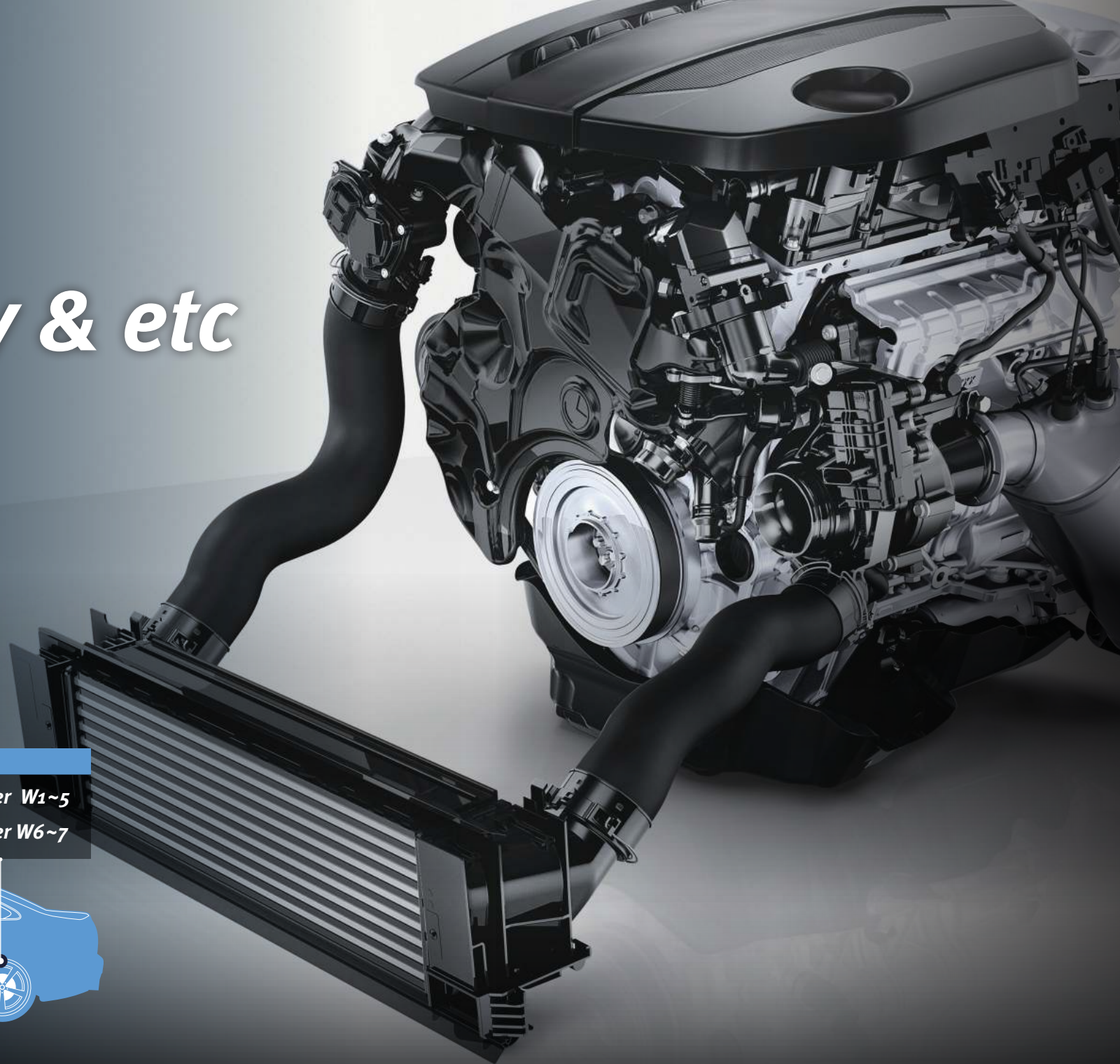
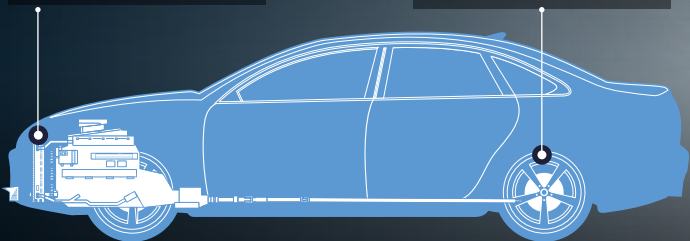

Customer (W1)

Automotive Industry

Power Train

Engine
Transmission &
Drive system

Chassis System

Steering
Suspension
Brake

Accessory & etc

Wheel
Air Conditioning
System
etc

Workpiece

Al Wheel



Customer Demand

1,500,000 units /year

2 min. / unit

Robot Automation

Solution

PUMA VAW800, PUMA AW560, Mynx 5400, Robot System(1)

High-productivity aluminum wheel processing vertical / Horizontal turning center / Powerful heavy-cutting vertical machining center



*PUMA VAW800 : 1Set

*PUMA AW560 : 1Set

*Mynx 5400 1Set

Process

- OP#10 Half out & In side
- OP#20 Half out side & Face
- OP#30 Bolt Hole

Option

- Measurement correction function
- Auto Measuring Unit (Marposs)
- Vision System for Air hole Positioning

Machining Option Installation Line / Line View



Customer (W2)

Automotive Industry

Power Train

Engine
Transmission &
Drive system

Chassis System

Steering
Suspension
Brake

Accessory & etc

Wheel
Air Conditioning
System
etc

Workpiece

Forged Wheel



Customer Demand

300,000 units /year

4min. 40 sec. / unit

Robot Automation

Solution

PUMA VAW800, Mynx 6500/50 + Loading/Unloading Robot System (2)

High-productivity aluminum wheel processing vertical turning center /
Powerful heavy-cutting vertical machining center



Process

- OP#10, 20 Turning, Al Wheel Inside
Turning, Al Wheel Outside
- OP#30, 40 Drilling, Bolt Hole & Air Hole
Drilling, Hand Hole & Valve Hole

Option

- Torque Ship Function
- Air Gap Sensing
- Remote Machine Offset

Machining Option Installation Line / Line View



Automotive Industry

Power Train

Engine
Transmission &
Drive system

Chassis System

Steering
Suspension
Brake

Accessory & etc

Wheel
Air Conditioning
System
etc

Workpiece

Al wheel



Customer Demand

118sec/pcs

Robot Interface

Solution

PUMA AW560MF

High-productivity aluminum wheel processing turning center



*PUMA AW560MF 6Sets



Process

OP#10 Wheel outside machining

Option

Robot Interface_I/O 16ea

Air Sensing Unit

High Pressure Coolant_7 bar

Machining Option Installation Line / Line View



Customer (W4)

Automotive Industry

Power Train

Engine
Transmission &
Drive system

Chassis System

Steering
Suspension
Brake

Accessory & etc

Wheel
Air Conditioning
System
etc

Workpiece

Al wheel



Customer Demand

178sec/pcs

Robot Interface

Solution

PUMA VAW800, VC630/5AX

High-productivity aluminum wheel processing vertical turning center /
Simultaneous 5-axis vertical machining center



*PUMA VAW800 8Sets

*VC630 5ax 6Sets

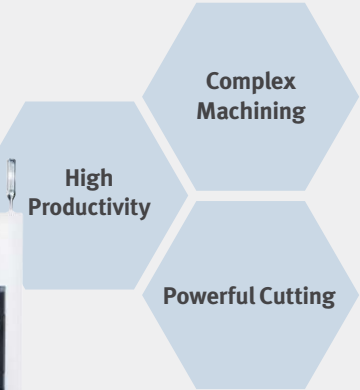

Process

- OP#10 O.D / I.D Rough Turning
- OP#20 O.D / I.D Rough Turning
- OP#30 O.D/I.D Fine Turning
- OP#40 (VAW800) O.D/I.D Fine Turning
- OP#50 (VC630/5AX) HOLT HOLE / AIR HOLE DRILL

Option

Preparation for Central Coolant

Robot Interface by Profinet

Spindle Motor Power Up : 60/75kW (VAW800)

Through Spindle Coolant_30bar (VC630)

Machining Option Installation Line / Line View



Customer (W5)

Automotive Industry

Power Train

Engine
Transmission &
Drive system

Chassis System

Steering
Suspension
Brake

Accessory & etc

Wheel
Air Conditioning
System
etc

Workpiece

AL Wheel



Customer Demand

120,000ea/year

133sec/ea

Robot

Solution

MYNX 6500 II

Powerful heavy-cutting vertical machining center

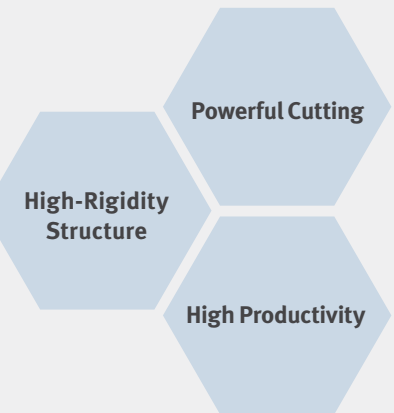

*1Set

Process

OP#30 DRILLING, CHAFMERING, ENDMILLING

Option

Work Locating Confirmation(Air Sensing)

Drum Filter Hinged Chip Conveyor

Rotary Table(2-axis)

MQL

Machining Option Installation Line / Line View



Customer (W6)

Automotive Industry

Power Train

Engine
Transmission &
Drive system

Chassis System

Steering
Suspension
Brake

Accessory & etc

Wheel
Air Conditioning
System
etc

Workpiece

AL Wheel_Face Finish(17~19")



Customer Demand

60sec/ea

Compensation by Feedback measuring equipment

Solution

PUMA AW 560 II

The high-productivity turning center is optimized for turning aluminum wheels for automobiles and motorbikes



*2Set

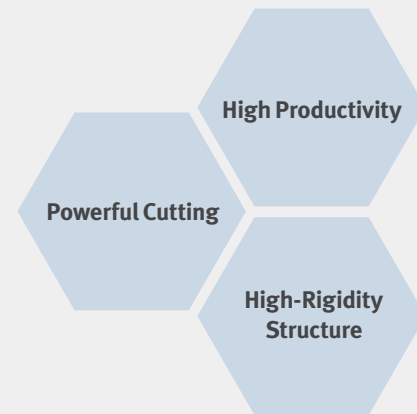

Process

FACE FINISHING

Option

Manual Measuring Unit (MARPOSS)

MQL (Mist Coolant)

Machining Option Installation Line / Line View



Customer (W7)

Automotive Industry

Power Train

Engine
Transmission &
Drive system

Chassis System

Steering
Suspension
Brake

Accessory & etc

Wheel
Air Conditioning
System
etc

Workpiece

AL Wheel_Hollow(19x8.5J") 1/3



Customer Demand

300,000ea/year

120sec/ea

Robot Automation

Solution

PUMA VAW800, PUMA AW550 II, MYNX6500 II

The high-productivity turning center is optimized for turning aluminum wheels for automobiles and motorbikes, Powerful heavy-cutting vertical machining center



*PUMA VAW800 : 2Set

*PUMA AW550II : 2Set

*Mynx 6500II : 2Sets + Robot Sys. 2Cells

Process

- OP#10 OD/ID & INNER FACE TURNING
- OP#20 OD & FRONT FACE TURNING
- OP#30 DRILLING, CHAFMERING, ENDMILLING

Option

- Work Locating Confirmation(Air Sensing)
- Auto Measuring Unit (MARPOSS)
- Air hole Position Sensor

Machining Option Installation Line / Line View



Customer (C1)

Automotive Industry

Power Train

Engine
Transmission &
Drive system

Chassis System

Steering
Suspension
Brake

Accessory & etc

Wheel
Air Conditioning
System
etc

Workpiece

Scroll



Customer Demand

600,000 units /year

1min. 30 sec. / unit

Gantry Loader Automation

Solution

PUMA TW2600M-GL

High-productivity 2-spindle horizontal turning center



2 Spindles

High Speed
Gantry Loader

High
Productivity

Process

OP#10 O.D & I.D Hole 가공

Option

Mist Collector

Coolant Chiller

Drum Chip Conveyor

Machining Option Installation Line / Line View



Customer (C2)

Automotive Industry

Power Train

Engine
Transmission &
Drive system

Chassis System

Steering
Suspension
Brake

Accessory & etc

Wheel
Air Conditioning
System
etc

Workpiece

Rear Head



Customer Demand

600,000 units /year

OP#10. 1min. 33min. OP#20. 3min. 21min.

Solution

T 4000

High-speed / High-productivity tapping center



*2Set

Process

- OP#10 Face Milling, Drilling, Tapping, Profile Grooving, Boring
- OP#20 Spot Facing, Drilling, Tapping, Boring

Option

Tapping Center	Gage Parts
Hyd. Fixture	
Rotary Tilting Table (5-AXIS)	

Machining Option Installation Line / Line View



Customer (C3)

Automotive Industry

Power Train

Engine
Transmission &
Drive system

Chassis System

Steering
Suspension
Brake

Accessory & etc

Wheel
Air Conditioning
System
etc

Workpiece

Compressor Cylinder



Customer Demand

300,000 units /year

56 sec. / unit

Solution

DNM 4500

Global standard vertical machining center, compact economical turning center



High Speed

Easy Machine
Operation

High
Productivity

*2Set

Process

OP#30 Comp. Cylinder Finish Boring

Option

Mapal Tool

ATC not use (only one tool)

Air Sensing Unit

Machining Option Installation Line / Line View



Customer (C4)

Automotive Industry

Power Train

Engine
Transmission &
Drive system

Chassis System

Steering
Suspension
Brake

Accessory & etc

Wheel
Air Conditioning
System
etc

Workpiece

Pulley Clutch



Customer Demand

600,000 units /year

18 sec. / unit

Gantry Loader Automation

Solution

PUMA TW2100 + Loading / Unloading Robot System (1)

High-productivity 2-spindle horizontal turning center



Process

OP#10 I.D Face Cutting

Option

Robot Interface

Inverter Hyd. Unit

MQL System

Machining Option Installation Line / Line View



Customer (C5)

Automotive Industry

Power Train

Engine
Transmission &
Drive system

Chassis System

Steering
Suspension
Brake

Accessory & etc

Wheel
Air Conditioning
System
etc

Workpiece

Swash Plate Comp



Customer Demand

850,000ea/year

27sec/ea

Solution

T3600D

High-speed / High-productivity tapping center



*1Set

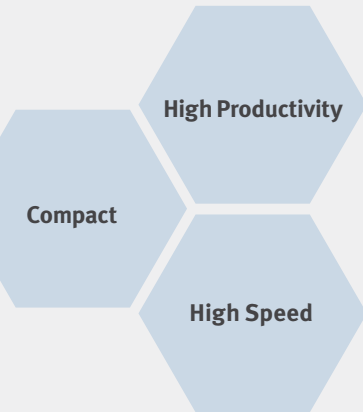

Process

OP#50 D8 ROUGH END MILLING,
D4 FINISH END MILLING

Option

Tool life & Tool load monitoring

Coolant Chiller

Tool Washing Unit

Work Locating Confirmation(Air Sensing)

Tool Broken(Needle)

Machining Option Installation Line / Line View



Customer (C6)

Automotive Industry

Power Train

Engine
Transmission &
Drive system

Chassis System

Steering
Suspension
Brake

Accessory & etc

Wheel
Air Conditioning
System
etc

Workpiece

Piston



Customer Demand

300,000ea/year

Gantry Loader

Solution

PUMA TW2100M_GL

Twin-Turret, Twin-Spindle HTC with Forward-Facing Chucks



* 2Set

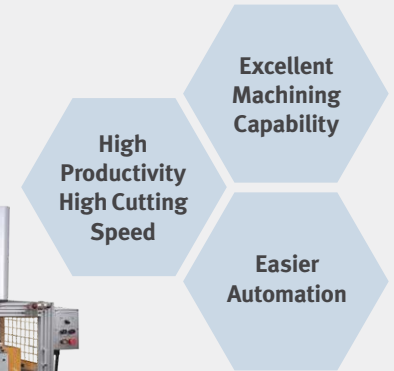

Option

- Auto Measuring Unit
- Hyd. Work Support-Tail stock, Live center
- Air Booster Tank
- Dual Pressure Chucking

Machining Option Installation Line / Line View



Customer (C7)

Automotive Industry

Power Train

Engine
Transmission &
Drive system

Chassis System

Steering
Suspension
Brake

Accessory & etc

Wheel
Air Conditioning
System
etc

Workpiece

Pulley



Customer Demand

50sec /ea

Gantry Loader

Solution

PUMA TW2600B_GL

Twin-Turret, Twin-Spindle HTC with Forward-Facing Chucks



*3Set

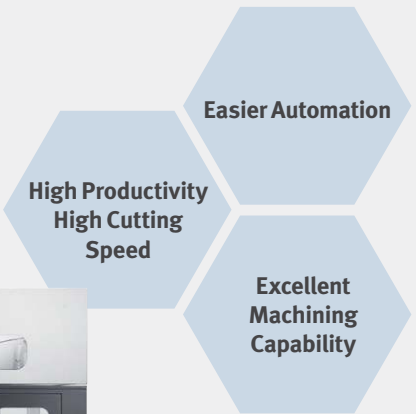

Option

- Spindle Nozzle A2-89 AP40Motor)
- Work Locating Confirmation(Air Sensing)
- Work& Tool Counter

Machining Option Installation Line / Line View



Customer (C8)

Automotive Industry

Power Train

Engine
Transmission &
Drive system

Chassis System

Steering
Suspension
Brake

Accessory & etc

Wheel
Air Conditioning
System
etc

Workpiece

Pump Bracket



Customer Demand

350,000ea/year

40sec/ea

Solution

PUMA V400

High Productivity Compact vertical turning center



*1set

High Cutting
Speed

Excellent
Machining
Capability

Safety
Reliability

Process

OP#20 I.D Rough Turning , Finish Turning

Option

Work Locating Confirmation(Airsensing)

Coolant Cooling Chiller

Chuck Cylinder 1530RE-UN

Machining Option Installation Line / Line View



Customer (C9)

Automotive Industry

Power Train

Engine
Transmission &
Drive system

Chassis System

Steering
Suspension
Brake

Accessory & etc

Wheel
Air Conditioning
System
etc

Workpiece

Ring (7Models)

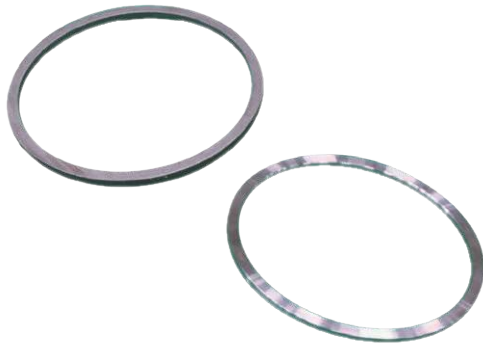

Customer Demand

942,000ea/year

33sec/ea

Gantry Loader

Solution

PUMA TW2600-GL320

Twin-Turret, Twin-Spindle HTC with Forward-Facing Chucks



*2Set

High Productivity
High Cutting
Speed

Easier Automation

Excellent
Machining
Capability

Option

Work Confirmation 6Port (Air Sensing)

A3 Type, Twin Gantry

Machining Option Installation Line / Line View



Customer (C10)

Automotive Industry

Power Train

Engine
Transmission &
Drive system

Chassis System

Steering
Suspension
Brake

Accessory & etc

Wheel
Air Conditioning
System
etc

Workpiece

Rotor



Customer Demand

300,000ea/year

OP1 : 79sec/ea, OP2 : 239sec/ea

Solution

PUMA TW2100M_GL , DNM4500

Twin-Turret, Twin-Spindle HTC with Forward-Facing Chucks
Global standard vertical machining center



Option

Work Locating Confirmation(Air Sensing)

TSC (Through Spindle Coolant)

Liner Scale (X,Y Axis)

Coolant Chiller, 5Axis Rotary Table

Machining Option Installation Line / Line View



Customer (C11)

Automotive Industry

Power Train

Engine
Transmission &
Drive system

Chassis System

Steering
Suspension
Brake

Accessory & etc

Wheel
Air Conditioning
System
etc

Workpiece

Shaft for Comp.



Customer Demand

300,000ea/year

72sec/ea

Gantry Loader

Solution

PUMA TW2100M_GL

Twin-Turret, Twin-Spindle HTC with Forward-Facing Chucks



* A2 1Set

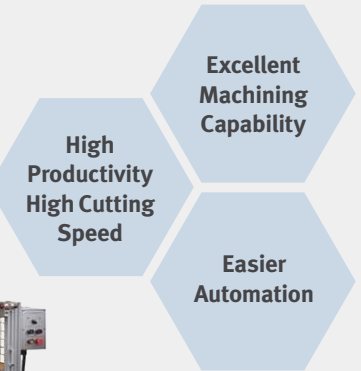

Process

OP#10 OD TURNING

Option

Work Locating Confirmation(air Sensing)

TTC (Through Tool Coolant)

Tool Life & Tool load monitoring

Coolant Chiller

Machining Option Installation Line / Line View



Customer (O1)

Automotive Industry

Power Train

Engine
Transmission &
Drive system

Chassis System

Steering
Suspension
Brake

Accessory & etc

Wheel
Air Conditioning
System
etc

Workpiece

ICS Core Plate

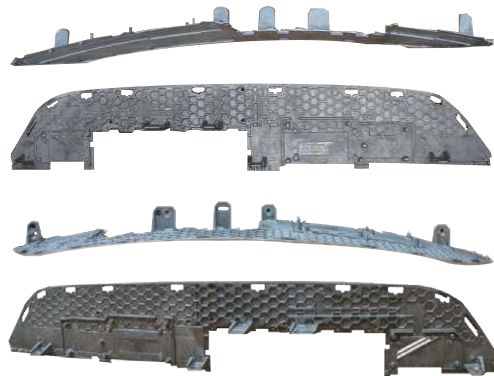

Customer Demand

40,000ea/year

Productivity

Solution

DNM 750L II, VCF 850SR II

Global standard vertical machining center Traveling Column VMC with Multiple Work Zones



*DNM 750L II : 1Set

* VCF 850SR II : 2Set

Process

- OP#10 Fixed position operate
- OP#20 5-axis operate

Option

Flood Coolant (1.8Kw)

Work Locating Confirmation(Air Sensing)

Tool Broken Unit(BK9)

Doosan Machine Tools in the World

In an effort to provide solutions that fit each partners' unique needs, we constantly innovate our thinking, processes, and the way we do business. These optimal solutions lay the foundation for the success of our partners, which adds value to our partners' businesses.

Global Sales and Service Support Network

- 4 Corporations
- 167 Dealer Networks
- 51 Technical Centers
- 200 Service Post
- 3 Factories

Technical Center: Sales Support, Service Support, Parts Support

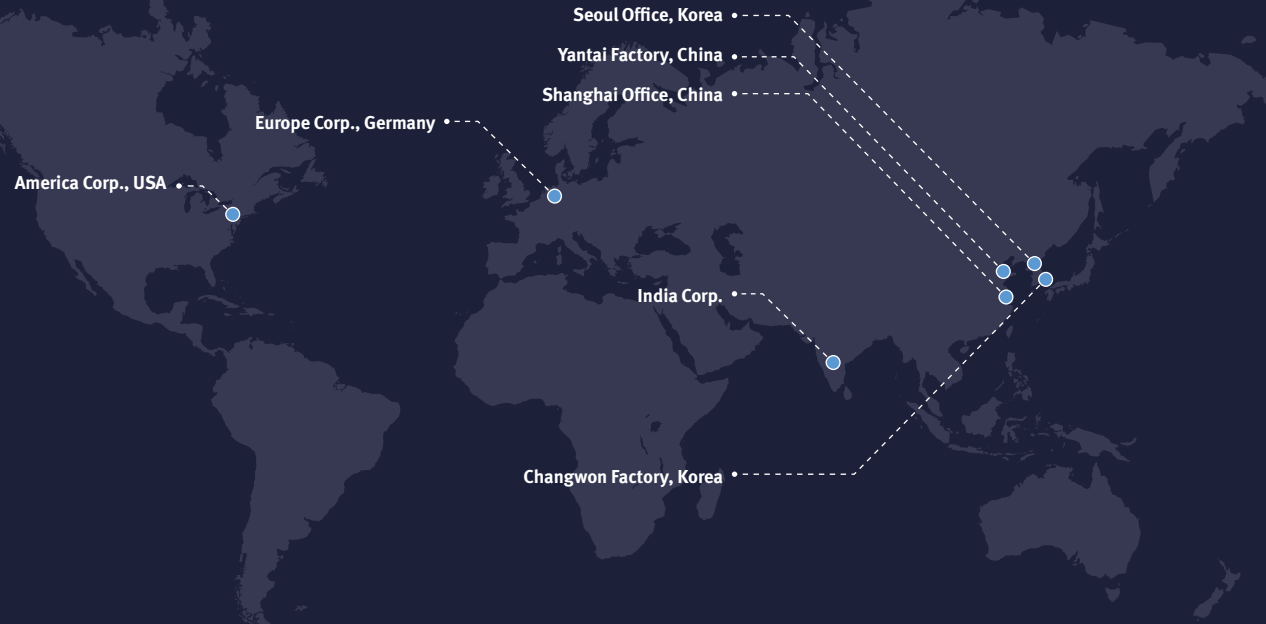

Supplying Parts

- Supplying parts without charges
- Supplying parts with charges
- Parts repair



Field Services

- On-site services
- Installment and trials
- Scheduled maintenance/ Preventive maintenance
- Repairs with/without charges



Technical Support

- Supporting machining technology
- Responding to technical inquiries
- Providing technical materials



Training

- Programming / Machine operation
- Maintenance
- Application engineering

Doosan Machine Tools

www.doosanmachinetools.com



Head Office

22FT Tower, 30, Sowol-ro 2-gil, Jung-gu, Seoul, Korea, 04637
Tel +82-2-6972-0370 / 0350
Fax +82-2-6972-0400

Doosan Machine Tools America

19A Chapin Rd., Pine Brook, NJ 07058, U.S.A.
Tel +1-973-618-2500
Fax +1-973-618-2501

Doosan Machine Tools Europe

Emdener Strasse 24, D-41540 Dormagen, Germany
Tel +49-2133-5067-100
Fax +49-2133-5067-111

Doosan Machine Tools India

No.82, Jakkuar Village, Yelahanka Hobli, Bangalore-560064

Doosan Machine Tools China

Room 101,201,301, Building 39 Xinzhuan Highway No.258 Songjiang District,China Shanghai(201612)
Tel +86-21-5445-1155
Fax +86-21-6405-1472

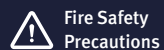

Fire Safety Precautions

There is a high risk of fire when using non-water-soluble cutting fluids, processing flammable materials, neglecting use coolants and modifying the machine without the consent of the manufacturer. Please check the SAFETY GUIDANCE carefully before using the machine.

- * For more details, please contact Doosan Machine Tools.
- * The specifications and information above-mentioned may be changed without prior notice.
- * Doosan Machine Tools Co., Ltd. is a subsidiary of MBK Partners. The trademark **DOOSAN** is used under a licensing agreement with Doosan Corporation, the registered trademark holder.