



COMELETRIC

Specialized rotary and control switches

seriesR10





R10 General Informations	
R10 Informazioni Generali	3-4
R301 Model	
Modello R301	5
R302 Model	
Modello R302	6
R303 Model	
Modello R303	7
R304 Model	
Modello R304	8
R308 / R309 Models	
Modelli R308 / R309	9
TR301 Model	
Modello TR301	10
Method for coding of R10 switches	
Metodo di ordinazione commutatori R10	11-12
Functions and configurations	
Funzioni e configurazioni	13-32
Front dimensions	
Dimensione frontali	33-34
Accessories	
Accessori	35
Custom made models	
Modelli speciali	36
Technical data	
Dati tecnici	37-38

R10 Control and Selector Switch is the latest innovative COMELETIC product.

R10 è l'ultima innovazione dei commutatori e selettori COMELETIC.

Its purpose is to gather together the different needs of Customers in various application fields, while keeping the main features of COMELETIC switches, with their robustness, reliability, durability and manufacturing flexibility

Thanks to its special features it is the perfect solution for installations on rolling stock applications such as trains, metros, trams or in any environments with high shock and vibration conditions.

The slim design of its body contact makes it ideal for fitting in panels, control and driver desks or any other narrow electrical device where a little space is available.

The main shaft and structure are in steel with high resistance zinc surface treatment (tropicalization) and the contacts are silver plated (gold plated on request), suitable for fitting in aggressive environments.

All these treatments protect the equipments from surrounding atmospheric conditions, heat, humidity, salt, etc.

Il suo scopo è di raggruppare in un singolo prodotto le esigenze dei clienti in diversi campi di applicazione, mantenendo inalterate le principali caratteristiche tecniche dei commutatori COMELETIC come la loro robustezza, affidabilità, durata e flessibilità di produzione.

Grazie alle sue speciali caratteristiche tecniche, è la soluzione perfetta per l'installazione su treni, metro, tram o in quelle applicazioni con elevate condizioni di shock e vibrazioni. La compattezza del gruppo contatti lo rende ideale per il montaggio su pannelli, quadri, banchi di comando o qualsiasi apparecchiatura elettrica con ristretti spazi disponibili.

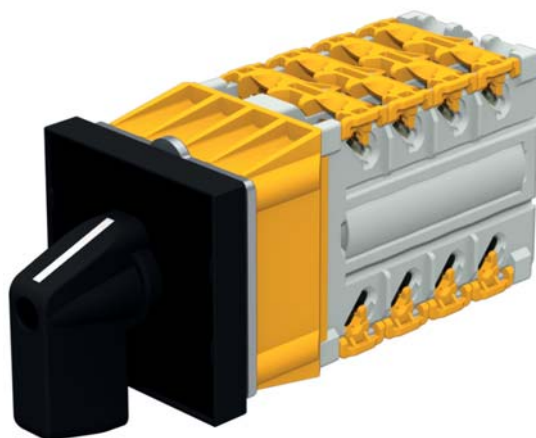

L'albero principale e la struttura sono in acciaio con zincatura superficiale ad alta resistenza (tropicalizzazione) ed i contatti sono argentati (dorati su richiesta), adatti per l'utilizzo in ambienti aggressivi.

Questi trattamenti proteggono il commutatore anche ove vi siano condizioni ambientali con alte temperature, forte umidità, alto tasso di salinità, ecc.

R10

The new R10 switch keeps in itself the usual characteristics of the **self cleaning contact system**, the main concept of all COMELETIC switches, the greatest and most reliable in the most heavy duty applications.

The self cleaning knife type contact system is the only way to properly switch DC currents.

The miscellaneous of shapes of rotor and fix contacts allow to perform different switching schemes in conformity to the customer requirements.



La nuova serie R10 mantiene invariato il **sistema di contatto auto pulente** che è la caratteristica fondamentale di tutti i commutatori COMELETIC, la migliore e la più affidabile nella maggior parte delle applicazioni gravose.

Il sistema di contatto a coltello auto pulente è l'unico che permette la commutazione in applicazioni in Corrente Continua.

La varietà di forme dei contatti fissi e mobili disponibili, permette di elaborare differenti schemi elettrici in conformità alle richieste dei clienti.

R10

Wiring connections are possible with pins, forks, as well as ring type cable lugs. By positioning the CLIP, IP20 protection degree is fully guaranteed, to work in safety conditions.

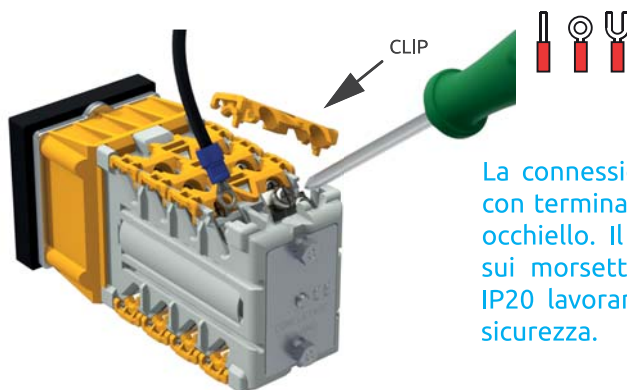

La connessione può essere effettuata con terminali a puntalino, forchetta ed occhiello. Il posizionamento delle clip sui morsetti garantisce la protezione IP20 lavorando in condizioni di totale sicurezza.

The access to the terminal is possible from both sides of the switch. Screw, inclined of 45°, can be easily reached even on wired switch.

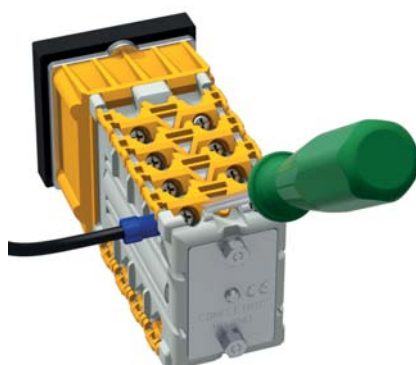

E' possibile l'ingresso dei terminali da entrambi i lati del commutatore. Le viti sono facilmente accessibili anche a commutatore cablato.

Thanks to the slim body, the switches can be fitted very close one to the other even in the narrowest panels.

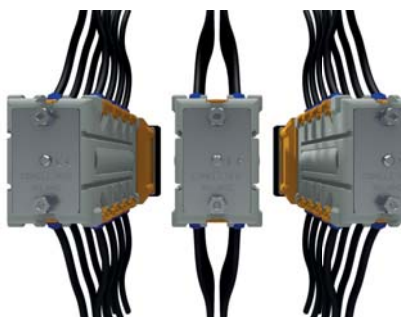

Grazie al ristretto ingombro, i commutatori possono essere montati molto vicino uno all'altro anche in pannelli con spazi angusti.

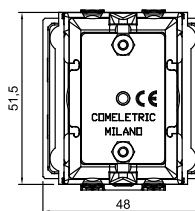

R10 Switches are available from 2 to 8 positions, fix or with spring return. They can be provided with many different kind of handles, standard types, pistol or oval in two different sizes, or with various locking devices from padlockable knobs to control keys or safety locks. Even customized front facilities can be designed. Great flexibility in developing customized electrical diagrams, text engravings and numbering of terminals in full accordance with technical specifications.

I commutatori R10 sono disponibili da 2 a 8 posizioni, fisse o con ritorno a molla. Possono essere forniti con diverse tipologie di manopola, standard, pistola ed ovale in due differenti dimensioni, o con vari sistemi di sicurezza come manopole lucchettabili, chiave di comando o blocco a chiave. Possono essere ideate anche strutture frontali personalizzate. Grande flessibilità nello sviluppare schemi elettrici personalizzati, incisioni dei frontali e numerazioni dei terminali, in totale conformità alle specifiche tecniche richieste.

R301 Model:

It can have from 2 to 8 positions fixed or with automatic return.

It may be supplied with frontplate size 48x48mm (Q4) or 64x64mm (Q7) standard type handle or Padlockable.

Realizza da 2 a 8 posizioni sia fisse che con molla di ritorno.

Può essere fornito con mostrina frontale 48x48mm (Q4) o 64x64mm (Q7) in versioni standard o con manopola lucchettabile.



Dimensions

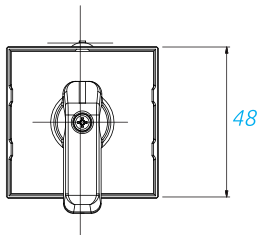

Square Frontplate

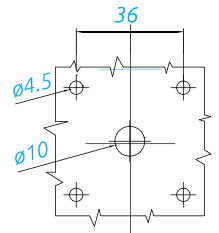
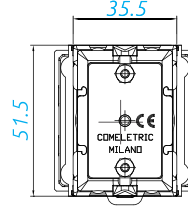
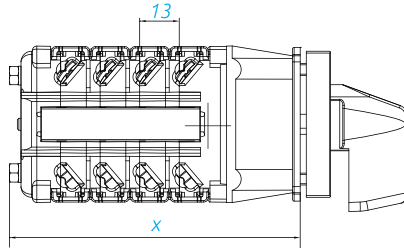

Panel Drilling

N° of packets	1	2	3	4	5	6	7	8	9	10	11	12	13	14	15
Length (mm)	57	70	83	96	109	122	135	148	161	174	187	200	213	226	239

R301 Frontplate R301 Mostrina

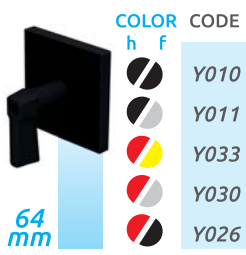
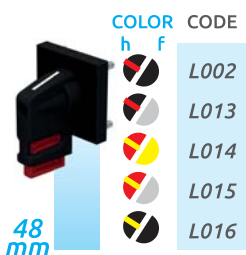
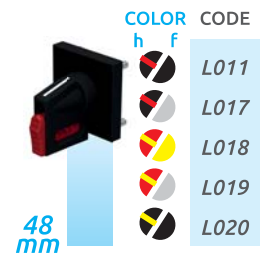
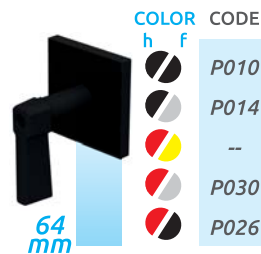
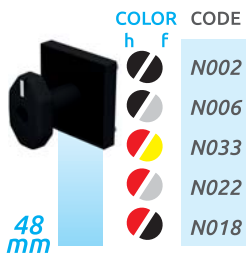
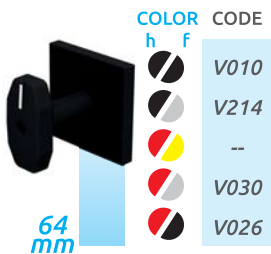
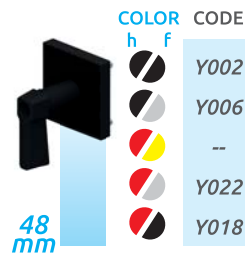

h=handle; f=frontplate
h=manopola; f=mostrina
Frontplate dimension on page 33/34
Dimensioni frontali a pag. 33/34

R302 Model:

Key Operated rotary switch.
Available with keys equal to each other or up to 200 different combinations.

Commutatore con operatore a chiave.
Disponibile con chiavi uguali tra loro o fino a 200 combinazioni diverse tra loro.

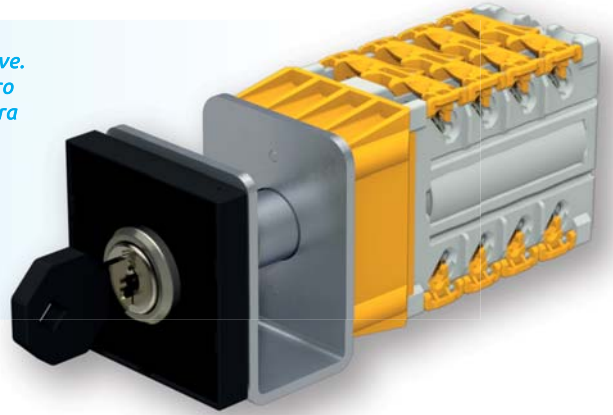

Dimensions

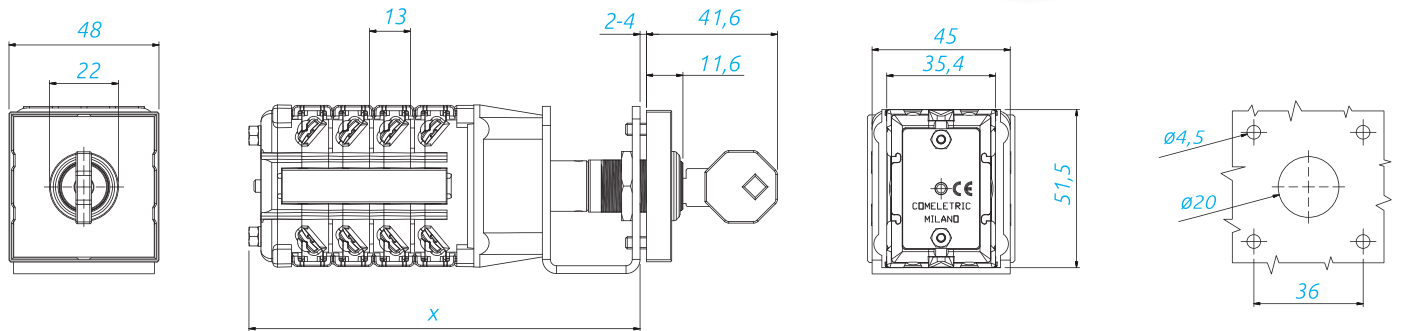

Square Frontplate

Panel Drilling

N° of packets	1	2	3	4	5	6	7	8
Length (mm)	85	98	111	124	137	150	163	176

R302 Frontplate R302 Mostrina

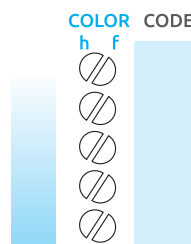
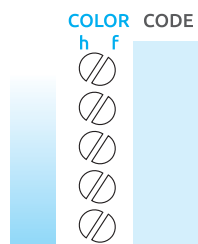
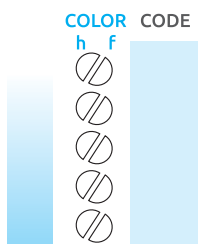
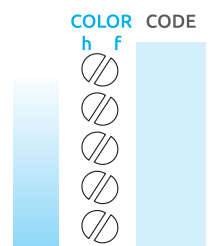
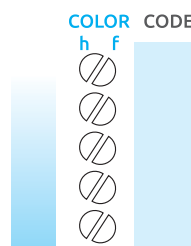

h=handle; f=frontplate
h=manopola; f=mostrina
Frontplate dimension on page 33/34
Dimensioni frontali a pag. 33/34

R303 Model:

Key Lock rotary switch.
Available with keys, that can be both equals or different one from the other (up to 500 different numbers).
MASTER KEY System is also available.

Commutatore con serratura di blocco.
Disponibile con chiavi uguali tra loro o fino a 500 combinazioni diverse tra loro. Disponibile anche con MASTER KEY.



Dimensions

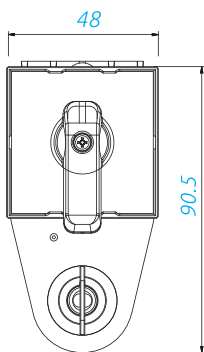

Square Frontplate

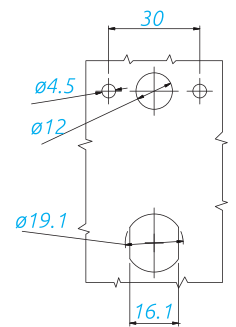
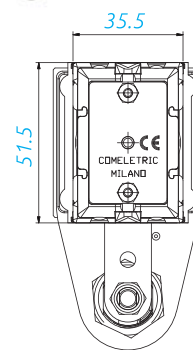
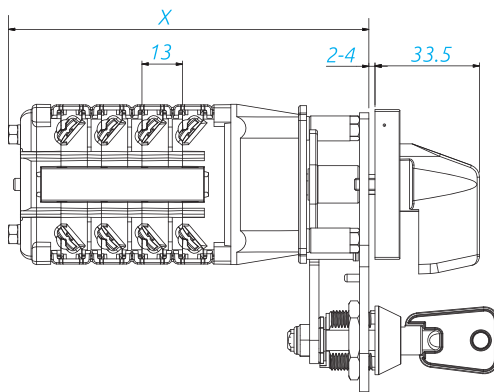

Panel Drilling

N° of packets	1	2	3	4	5	6	7	8	9	10	11	12	13	14	15
Length (mm)	73	90	103	116	129	142	155	168	181	194	207	220	233	246	259

R303 Frontplate R303 Mostrina

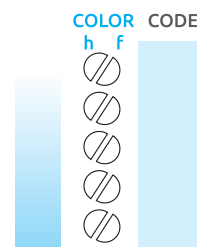
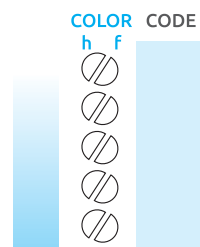
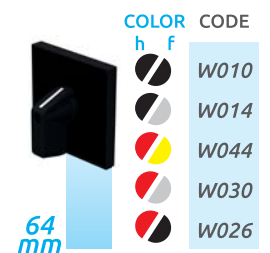
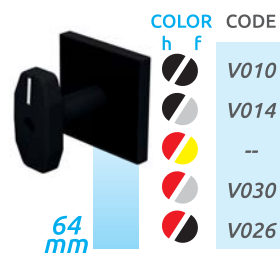
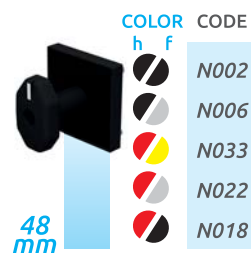
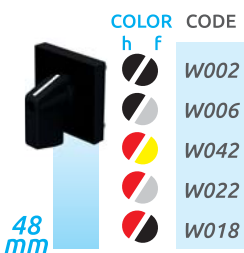

h=handle; f=frontplate
h=manopola; f=mostrina
Frontplate dimension on page 33/34
Dimensioni frontali a pag. 33/34

R304 Model:

The Mechanical trip indicator shows the indication of the last command given.

Il Dispositivo meccanico di avvenuta manovra indica l'ultimo comando effettuato dal commutatore.



Dimensions

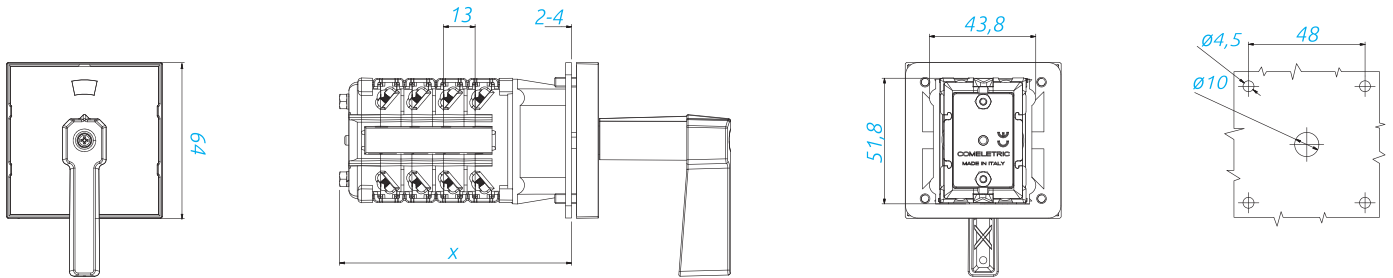

Square Frontplate

Panel Drilling

N° of packets	1	2	3	4	5	6	7	8	9	10	11	12	13	14
Length (mm)	56	69	82	95	108	121	134	147	160	173	186	199	212	225

R304 Frontplate R304 Mostrina

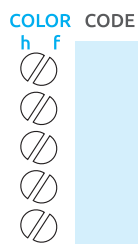
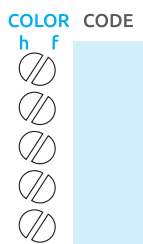
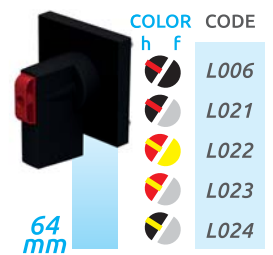
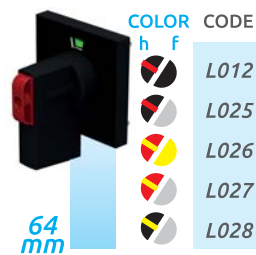
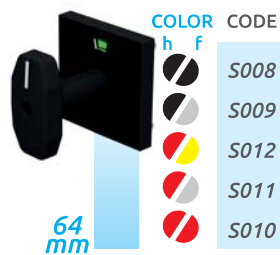

h=handle; f=frontplate
h=manopola; f=mostrina
Frontplate dimension on page 33/34
Dimensioni frontali a pag. 33/34

Models: **R308** push to operate **R309** pull to operate

This switch is mainly used to avoid involuntary operations. It can be handled only by **PUSHING** (R308) or **PULLING** (R309) the knob of the switch.

Questo dispositivo di sicurezza serve per evitare manovre accidentali. Il commutatore può essere manovrato solamente **PREMENDO** (R308) o **TIRANDO** (R309) la manopola del commutatore.

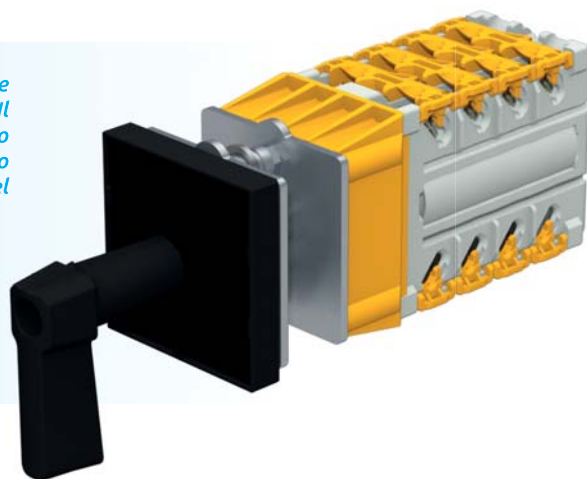

Dimensions

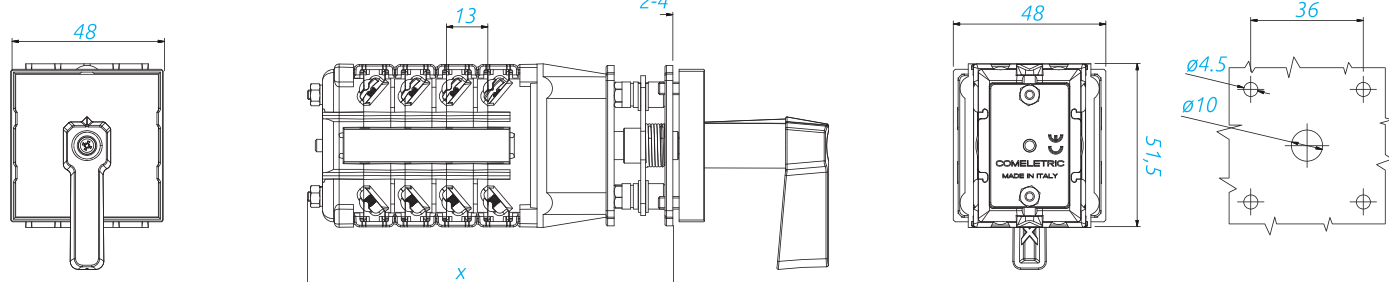

Square Frontplate

Panel Drilling

N° of packets	1	2	3	4	5	6	7	8	9	10	11	12
Length (mm)	56	69	82	95	108	121	134	147	160	173	186	199

R308 / 309 Frontplate R308 / 309 Mostrine

48 mm

COLOR	h	f	CODE
Black/White	h	f	Z073
Black/White	h	f	Z074
Red/Yellow	h	f	Z075
Red/White	h	f	Z076
Red/Black	h	f	Z077

48 mm

COLOR	h	f	CODE
Black/White	h	f	Z002
Black/White	h	f	Z034
Red/Yellow	h	f	--
Red/White	h	f	Z018
Red/Black	h	f	--

48 mm

COLOR	h	f	CODE
Black/White	h	f	Z010
Black/White	h	f	Z042
Red/Yellow	h	f	--
Red/White	h	f	Z026
Red/Black	h	f	Z050

64 mm

COLOR	h	f	CODE
Black/White	h	f	Z014
Black/White	h	f	Z046
Red/Yellow	h	f	--
Red/White	h	f	Z030
Red/Black	h	f	Z054

48 mm

COLOR	h	f	CODE
Black/White	h	f	Z046
Black/White	h	f	Z065
Red/Yellow	h	f	Z060
Red/White	h	f	Z067
Red/Black	h	f	Z068

64 mm

COLOR	h	f	CODE
Black/White	h	f	Z060
Black/White	h	f	Z069
Red/Yellow	h	f	Z070
Red/White	h	f	Z071
Red/Black	h	f	Z072

COLOR	h	f	CODE
Black/White	h	f	
Black/White	h	f	
Black/White	h	f	
Black/White	h	f	

h=handle; f=frontplate
h=manopola; f=mostrina
Frontplate dimension on page 33/34
Dimensioni frontali a pag. 33/34

TR301 Model:

This device is used to connect several switches so that they can be operated simultaneously, thanks to this system a large number of contacts can be obtained in a minimal space.

Questo dispositivo viene utilizzato per collegare più commutatori in modo che possano essere manovrati contemporaneamente. Grazie a questo sistema si possono ottenere un elevato numero di contatti riducendo al minimo l'ingombro in profondità.

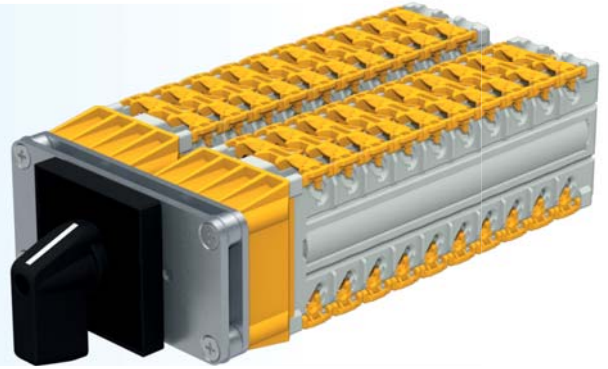

Dimensions

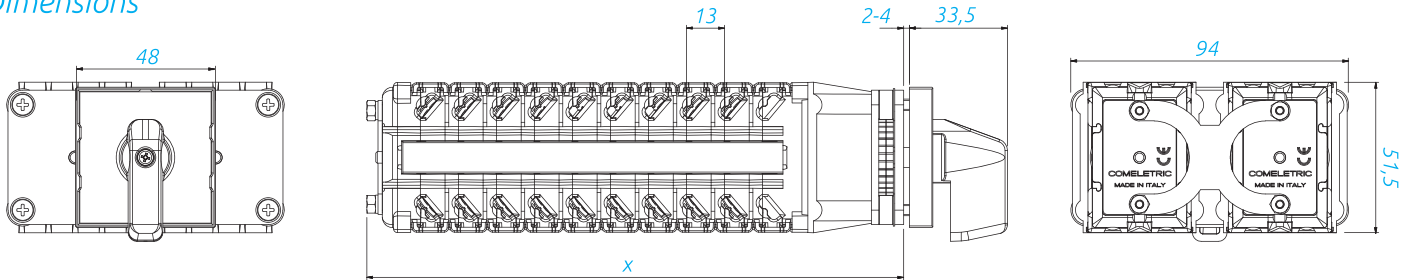

Square Frontplate 48

N° of packets	7+7	8+8	9+9	10+10	11+11	12+12	13+13	14+14	15+15	16+16	17+17	18+18
Length (mm)	147	160	173	186	199	212	225	238	251	264	277	290

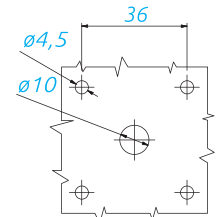

Panel Drilling

TR301 Frontplate TR301 Mostrine

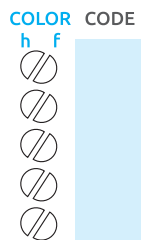
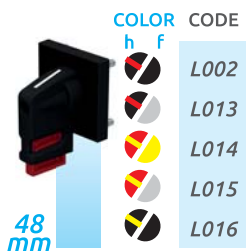
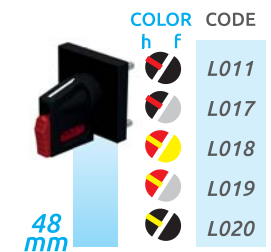
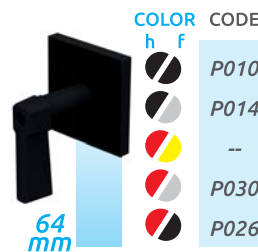
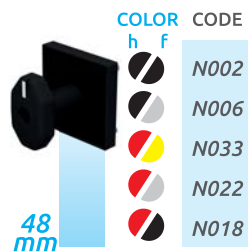
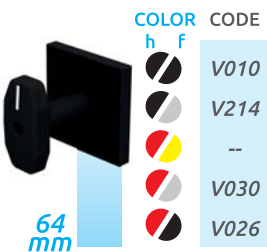
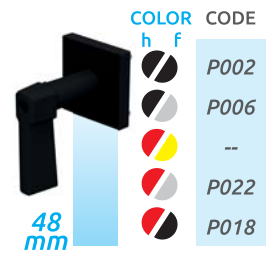
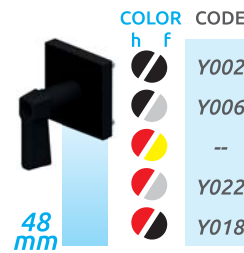
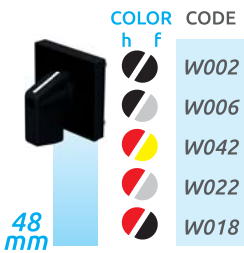

h=handle; f=frontplate
h=manopola; f=mostrina
Frontplate dimension on page 33/34
Dimensioni frontali a pag. 33/34

Metodo di ordinazione

Commutatori R10

In questo Catalogo si possono trovare alcuni schemi e le istruzioni per comporre autonomamente i codici d'ordinazione dei commutatori Serie R10 standard.

Per schemi Speciali o schemi non presenti in questo catalogo utilizzare il form. a pag. XX .

Gli schemi del presente catalogo ed il loro utilizzo nei codici sono applicabili esclusivamente alle serie di commutatori R10 e non per le altre Serie.

Codice prodotto

Esempio commutatore a manopola	R301	202002			-	W002
Esempio commutatore con chiave	R302	202002	07	D	-	K001
	①	②	③	④		⑤

① Modello del Commutatore.

Come n° di Modello si intende il montaggio e la forma costruttiva univoca di ogni commutatore
questo riferimento identifica la specifica costruzione meccanica del commutatore .

Questo n° di Modello viene indicato nel catalogo insieme al relativo disegno di ingombro e della foratura del pannello.

② Schema elettrico.

Questo numero rappresenta l'indicazione dello schema del commutatore richiesto.

Esso comprende lo schema elettrico ed il movimento della manopola , in riferimento agli schemi di seguito rappresentati.

③ Programma Bloccaggio/Estrazione chiave o altro.

Questo numero viene utilizzato solamente nei commutatori con chiave di comando , serratura di blocco, commutatore lucchettabile e commutatori con manopola estraibile.

Esso rappresenta la posizione in cui il commutatore può essere bloccato.

Il bloccaggio dei commutatori con chiave di comando o serratura di blocco avviene mediante l'estrazione della chiave dallo stesso.

Nei modelli con manopola estraibile la posizione il bloccaggio è la medesima di quelli a chiave , nei modelli lucchettabili il riferimento è invece la posizione dove viene data la possibilità di inserire il lucchetto.

La tabella di riferimento per il N° di programma di bloccaggio è presente a pag. xx del presente catalogo e deve essere conforme allo spostamento della manopola previsto nello schema di riferimento del commutatore.

④ Chiave uguali tra di loro o chiavi differenti tra di loro.

Questo numero viene utilizzato solamente nei commutatori con chiave di comando , serratura di blocco.

Esso rappresenta se le chiavi dei commutatori devono essere uguali tra loro o Differenti tra loro.

La lettera "D" è l'indicazione di chiavi diverse tra di loro , quindi ogni commutatore ordinato avrà una chiave unica , quindi non è possibile manovrare altri commutatori con la medesima chiave.

Se non indicata i commutatori vengono forniti tutti con medesima chiave .

⑤ Tipo dimensione e colore Finitura (parte frontale)

Questo numero indica il tipo la dimensione ed il colore delle manopole e Finiture frontali del commutatore

Method for coding of R10 switches.

In the present catalogue you will find examples of diagrams and the instruction enabling you to the creation by yourself of the ordering codes of R10 switches (standard).
For all the other special diagrams or any scheme which is not present in this catalogue, please use the form on page XX.
The diagrams represented in this catalogue and their use in the codes are strictly related to R10 switches and not to all the others.

Switch code

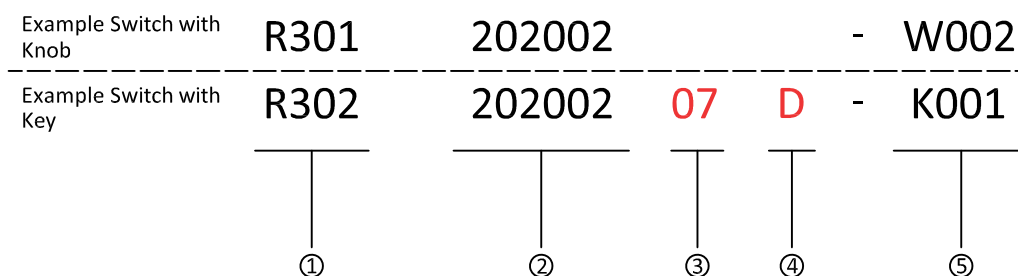

① Switch model

As switch model it is meant the kind of fitting and the mechanical structure of each specific switch (non è il caso di inserire degli esempi?)
This reference is mentioned in the catalogue along with the dimensional drawing and the cutout of the panel.

② Electrical diagram

This reference is referred to the electrical diagram of the switch.
It includes the diagram and the movement of the knob, with reference to diagrams present in the following pages of the catalogue.

③ Locking/extraction program of keys or any other locking facility.

This reference is not used in those switches key operated, with ey lock, padlockable or with removable knob.
It gives the positions where the switch must be blocked.
The locking of any type of key switch is done by removing the key in the required position, the same for the switches with removable handle.
On the contrary, for switches with padlockable devices, this code reference will state where the padlockable could be inserted and blocking the rotation of the knob.
The table with locking references is on page XX of this catalogue and it must be conform to the switching positions foreseen in the electrical diagram referred to the switch.

④ Alike or different key references.

This reference is present only in codes of switches with a key device.
It states if the switches must be equipped with keys with same references or all different ones.
Letter "D" at the end of the code means all different key references, so each switch will be provided with a unique key, the key of one switch could not be used for operating any other switch of the same supply.
If not clearly mentioned in the order, the switches will be provided keys all alike.

⑤ Dimension and front colour

This is referred to the dimension of the frontplate and its and knob's colour.

Switch Function and Configuration

Function	Handle Movements	Decks	Code	Connection Diagram
On/Off Switches				
1 pole 2 pole 3 pole 4 pole 5 pole 6 pole 7 pole 8 pole 9 pole 10 pole 11 pole 12 pole		1 2 3 4 5 6 7 8 9 10 11 12	201019 202019 203019 204019 205019 206019 207019 208019 209019 210019 211019 212019	
1 pole 2 pole 3 pole 4 pole 5 pole 6 pole 7 pole 8 pole 9 pole 10 pole 11 pole 12 pole		1 2 3 4 5 6 7 8 9 10 11 12	201020 202020 203020 204020 205020 206020 207020 208020 209020 210020 211020 212020	

Double Trow Switch Without "0" position.

1 pole 2 pole 3 pole 4 pole 5 pole 6 pole 7 pole 8 pole 9 pole 10 pole 11 pole 12 pole		1 2 3 4 5 6 7 8 9 10 11 12	201001 202001 203001 204001 205001 206001 207001 208001 209001 210001 211001 212001	
1 pole 2 pole 3 pole 4 pole 5 pole 6 pole 7 pole 8 pole 9 pole 10 pole 11 pole 12 pole		1 2 3 4 5 6 7 8 9 10 11 12	201002 202002 203002 204002 205002 206002 207002 208002 209002 210002 211002 212002	
1 pole 2 pole 3 pole 4 pole 5 pole 6 pole 7 pole 8 pole 9 pole 10 pole 11 pole 12 pole		1 2 3 4 5 6 7 8 9 10 11 12	201003 202003 203003 204003 205003 206003 207003 208003 209003 210003 211003 212003	

Switch Function and Configuration

Function	Handle Movements	Decks	Code	Connection Diagram
----------	------------------	-------	------	--------------------

2 Positions switch with 1 input & 2 Output in each deck

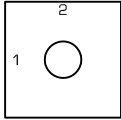
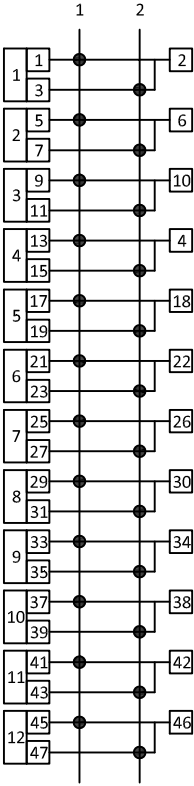
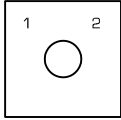
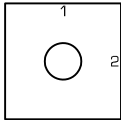
1 pole 2 pole 3 pole 4 pole 5 pole 6 pole 7 pole 8 pole 9 pole 10 pole 11 pole 12 pole		1 2 3 4 5 6 7 8 9 10 11 12	201007 202007 203007 204007 205007 206007 207007 208007 209007 210007 211007 212007	
1 pole 2 pole 3 pole 4 pole 5 pole 6 pole 7 pole 8 pole 9 pole 10 pole 11 pole 12 pole		1 2 3 4 5 6 7 8 9 10 11 12	201008 202008 203008 204008 205008 206008 207008 208008 209008 210008 211008 212008	
1 pole 2 pole 3 pole 4 pole 5 pole 6 pole 7 pole 8 pole 9 pole 10 pole 11 pole 12 pole		1 2 3 4 5 6 7 8 9 10 11 12	201009 202009 203009 204009 205009 206009 207009 208009 209009 210009 211009 212009	

2 Positions switch with Make before Break Contacts

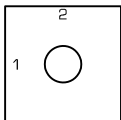
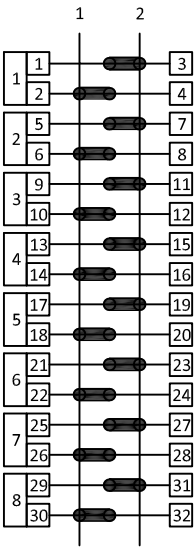
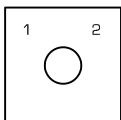
1 pole 2 pole 3 pole 4 pole 5 pole 6 pole 7 pole 8 pole		1 2 3 4 5 6 7 8	201055 202055 203055 204055 205055 206055 207055 208055	
1 pole 2 pole 3 pole 4 pole 5 pole 6 pole 7 pole 8 pole		1 2 3 4 5 6 7 8	201056 202056 203056 204056 205056 206056 207056 208056	

Switch Function and Configuration

Function	Handle Movements	Decks	Code	Connection Diagram
----------	------------------	-------	------	--------------------

3 pos. switch with "0" Position with electrically isolated contacts

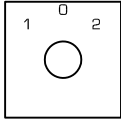
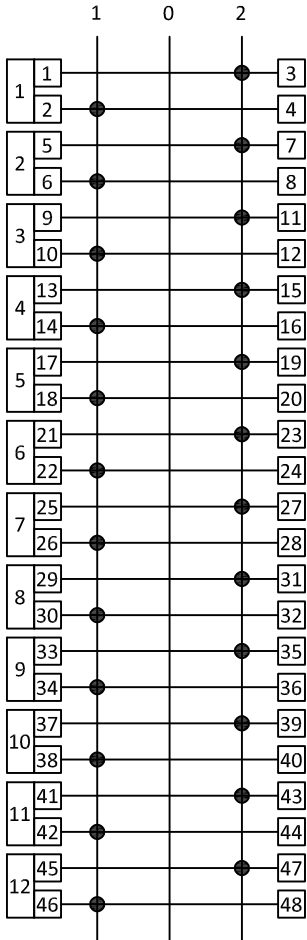
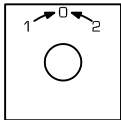
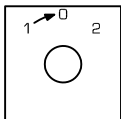
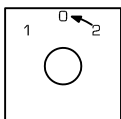
1 pole 2 pole 3 pole 4 pole 5 pole 6 pole 7 pole 8 pole 9 pole 10 pole 11 pole 12 pole		1 2 3 4 5 6 7 8 9 10 11 12	301001 302001 303001 304001 305001 306001 307001 308001 309001 310001 311001 312001	
With Spring return to "0" position from pos."1" & pos."2". 1 pole 2 pole 3 pole 4 pole 5 pole 6 pole 7 pole 8 pole		1 2 3 4 5 6 7 8	M301001 M302001 M303001 M304001 M305001 M306001 M307001 M308001	
With Spring return to "0" position from pos."1". 1 pole 2 pole 3 pole 4 pole 5 pole 6 pole 7 pole 8 pole		1 2 3 4 5 6 7 8	301012 302012 303012 304012 305012 306012 307012 308012	
With Spring return to "0" position from pos."2". 1 pole 2 pole 3 pole 4 pole 5 pole 6 pole 7 pole 8 pole		1 2 3 4 5 6 7 8	301020 302020 303020 304020 305020 306020 307020 308020	

Switch Function and Configuration

Function	Handle Movements	Decks	Code	Connection Diagram
----------	------------------	-------	------	--------------------

3 pos. switch with "0" Position with 1 input and 2 output in each deck.

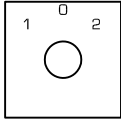
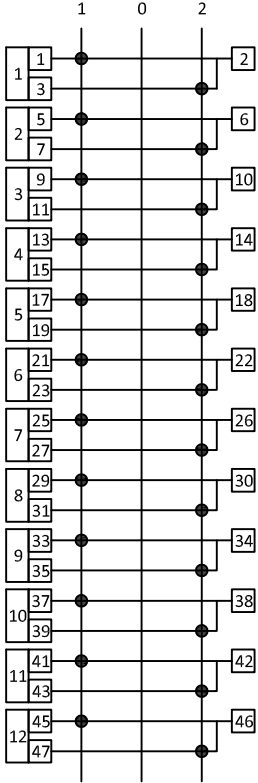
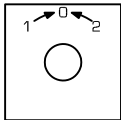
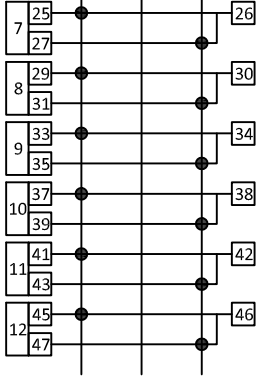
1 pole 2 pole 3 pole 4 pole 5 pole 6 pole 7 pole 8 pole 9 pole 10 pole 11 pole 12 pole		1 2 3 4 5 6 7 8 9 10 11 12	301003 302003 303003 304003 305003 306003 307003 308003 309003 310003 311003 312003	
With Spring return to "0" position from pos."1" & pos."2". 1 pole 2 pole 3 pole 4 pole 5 pole 6 pole 7 pole 8 pole		1 2 3 4 5 6 7 8	M301003 M302003 M303003 M304003 M305003 M306003 M307003 M308003	

3 pos. switch without "0" Position with 1 input and 3 output in each deck.

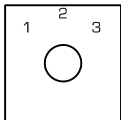
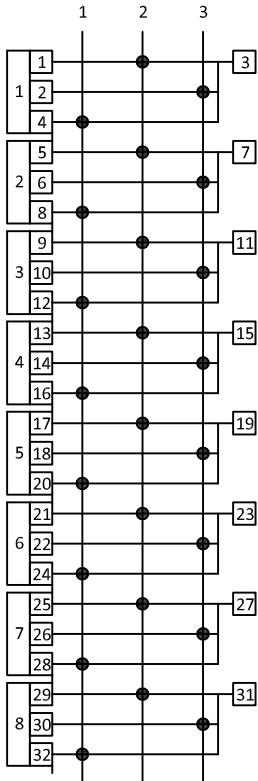
1 pole 2 pole 3 pole 4 pole 5 pole 6 pole 7 pole 8 pole 9 pole 10 pole 11 pole 12 pole		1 2 3 4 5 6 7 8 9 10 11 12	301004 302004 303004 304004 305004 306004 307004 308004 309004 310004 311004 312004	
---	---	---	--	---

Switch Function and Configuration

Function	Handle Movements	Decks	Code	Connection Diagram
----------	------------------	-------	------	--------------------

3 pos. switch Without "0" Position, with electrically isolated contacts.

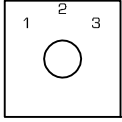
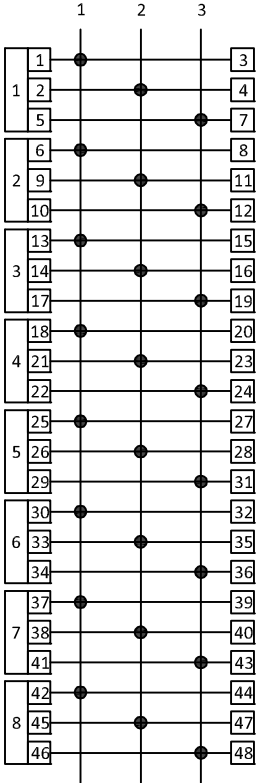
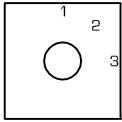
1 pole 2 pole 3 pole 4 pole 5 pole 6 pole 7 pole 8 pole		2 3 5 6 8 9 11 12	302078 303078 305078 306078 308078 309078 311078 312078	
1 pole 2 pole 3 pole 4 pole 5 pole 6 pole 7 pole 8 pole		2 3 5 6 8 9 11 12	302134 303134 305134 306134 308134 309134 311134 312134	

3 pos. switch with "0" Position, with electrically isolated contacts.

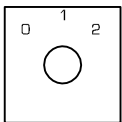
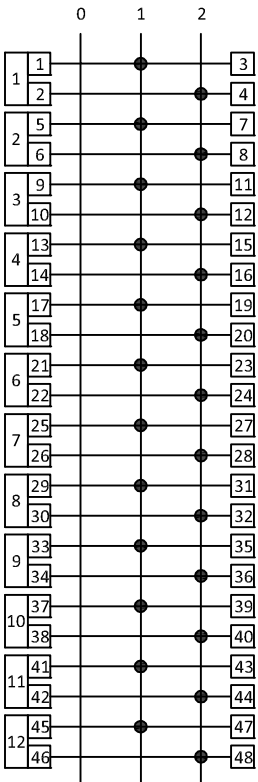
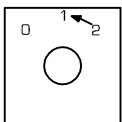
1 pole 2 pole 3 pole 4 pole 5 pole 6 pole 7 pole 8 pole 9 pole 10 pole 11 pole 12 pole		1 2 3 4 5 6 7 8 9 10 11 12	301016 302016 303016 304016 305016 306016 307016 308016 309016 310016 311016 312016	
With Spring return to "0" position from pos. "2". 1 pole 2 pole 3 pole 4 pole 5 pole 6 pole 7 pole 8 pole		1 2 3 4 5 6 7 8	301048 302048 303048 304048 305048 306048 307048 308048	

Switch Function and Configuration

Function	Handle Movements	Decks	Code	Connection Diagram
----------	------------------	-------	------	--------------------

4 pos. switch With "0" Position, with electrically isolated contacts.

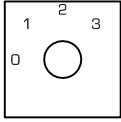
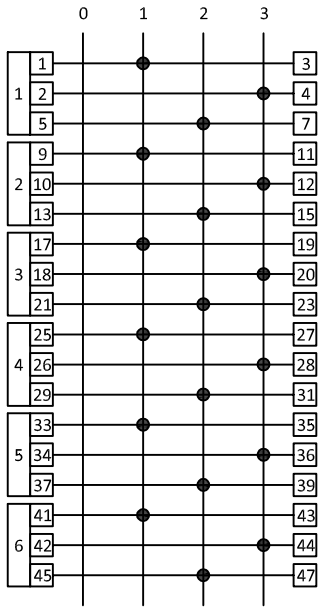
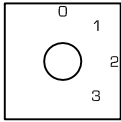
1 pole 2 pole 3 pole 4 pole 5 pole 6 pole		2 4 6 8 10 12	402008 404008 406008 408008 410008 412008	
1 pole 2 pole 3 pole 4 pole 5 pole 6 pole		2 4 6 8 10 12	402087 404087 406087 408087 410087 412087	

4 pos. switch with "0" Position, with 1 Input and 3 output per Pole.

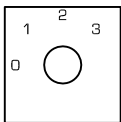
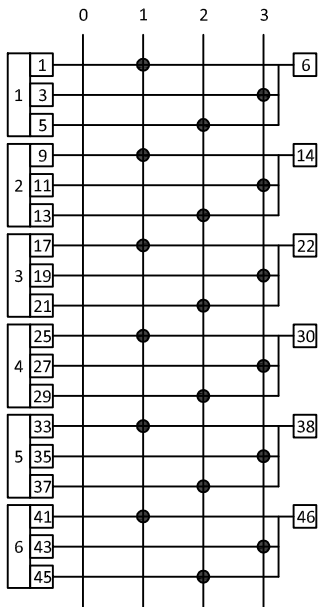
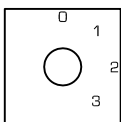
1 pole 2 pole 3 pole 4 pole 5 pole 6 pole		2 4 6 8 10 12	402011 404011 406011 408011 410011 412011	
1 pole 2 pole 3 pole 4 pole 5 pole 6 pole		2 4 6 8 10 12	402088 404088 406088 408088 410088 412088	

Switch Function and Configuration

Function	Handle Movements	Decks	Code	Connection Diagram
----------	------------------	-------	------	--------------------

4 pos. switch Without "0" Position, with electrically isolated contacts.

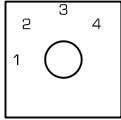
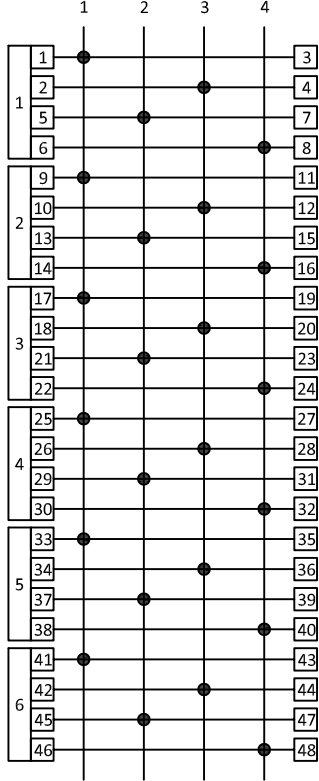
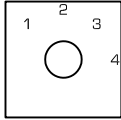
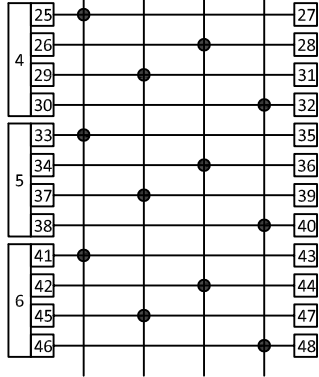
1 pole 2 pole 3 pole 4 pole 5 pole 6 pole		2 4 6 8 10 12	402003 404003 406003 408003 410003 412003	
1 pole 2 pole 3 pole 4 pole 5 pole 6 pole		2 4 6 8 10 12	402017 404017 406017 408017 410017 412017	

4 pos. switch without "0" Position, with 1 Input and 4 output per Pole.

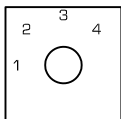
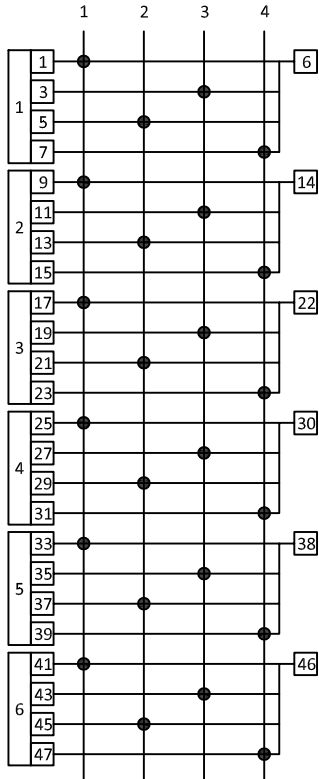
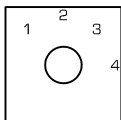
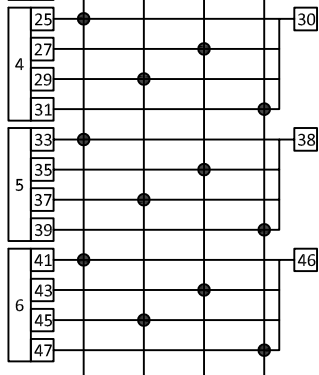
1 pole 2 pole 3 pole 4 pole 5 pole 6 pole		2 4 6 8 10 12	402007 404007 406007 408007 410007 412007	
1 pole 2 pole 3 pole 4 pole 5 pole 6 pole		2 4 6 8 10 12	402089 404089 406089 408089 410089 412089	

Switch Function and Configuration

Function	Handle Movements	Decks	Code	Connection Diagram
----------	------------------	-------	------	--------------------

5 pos. switch With "0" Position, with electrically isolated contacts.

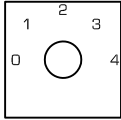
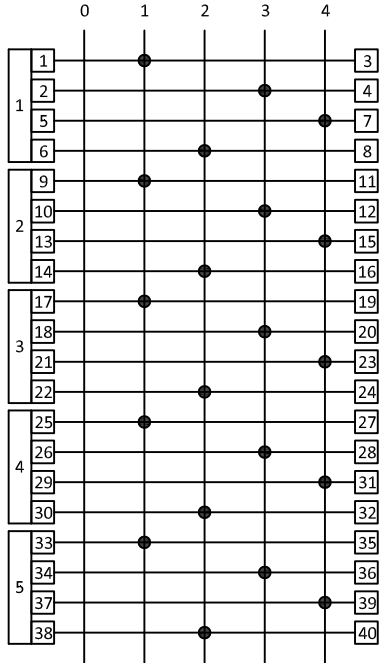
1 pole 2 pole 3 pole 4 pole 5 pole		2 4 6 8 10	502020 504020 506020 508020 510020	
--	---	------------------------	--	--

5 pos. switch with "0" Position, with 1 Input and 4 output per Pole.

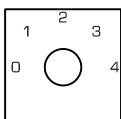
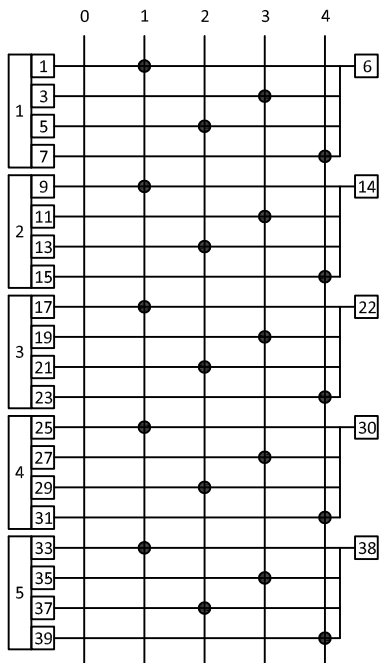
1 pole 2 pole 3 pole 4 pole 5 pole		2 4 6 8 10	502010 504010 506010 508010 510010	
--	---	------------------------	--	---

Switch Function and Configuration

Function	Handle Movements	Decks	Code	Connection Diagram
----------	------------------	-------	------	--------------------

5 pos. switch Without "0" Position, with electrically isolated contacts.

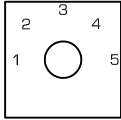
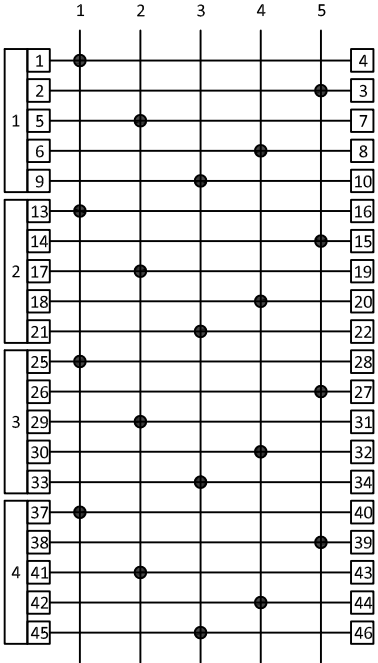
1 pole 2 pole 3 pole 4 pole		3 6 9 12	503018 506018 509018 512018	
--------------------------------------	---	-------------------	--------------------------------------	--

5 pos. switch without "0" Position, with 1 Input and 5 output per Pole.

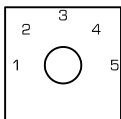
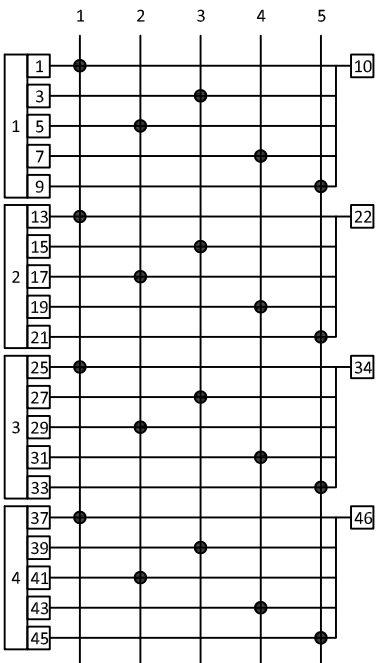
1 pole 2 pole 3 pole 4 pole		3 6 9 12	503013 506013 509013 512013	
--------------------------------------	---	-------------------	--------------------------------------	---

Switch Function and Configuration

Function	Handle Movements	Decks	Code	Connection Diagram
----------	------------------	-------	------	--------------------

6 pos. switch With "0" Position, with electrically isolated contacts.

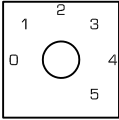
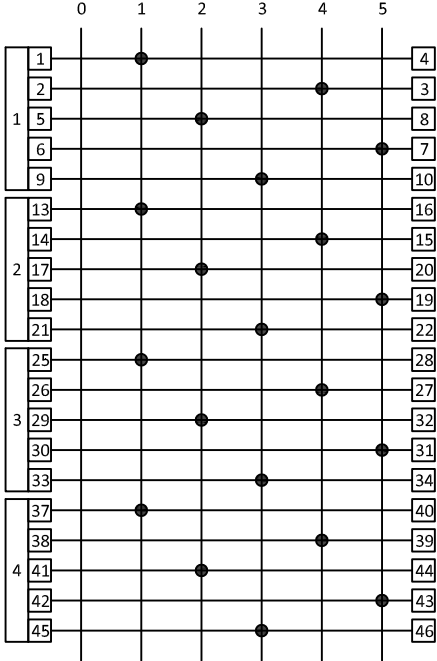
1 pole 2 pole 3 pole 4 pole		3 6 9 12	603009 606009 609009 612009	
--------------------------------------	---	-------------------	--------------------------------------	---

6 pos. switch with "0" Position, with 1 Input and 5 output per Pole.

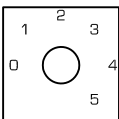
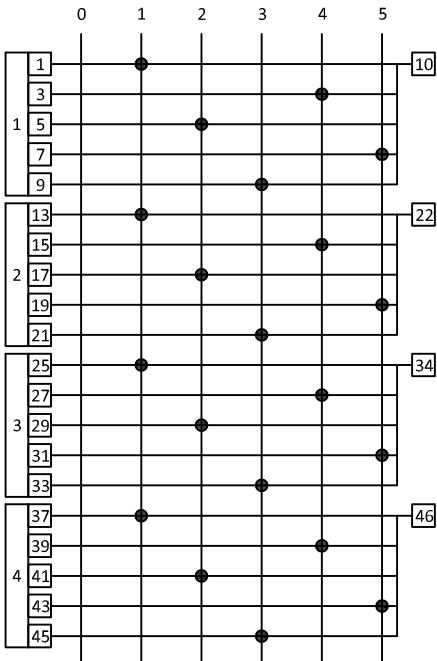
1 pole 2 pole 3 pole 4 pole		3 6 9 12	603003 606003 609003 612003	
--------------------------------------	---	-------------------	--------------------------------------	--

Switch Function and Configuration

Function	Handle Movements	Decks	Code	Connection Diagram
----------	------------------	-------	------	--------------------

6 pos. switch Without "0" Position, with electrically isolated contacts.

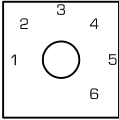
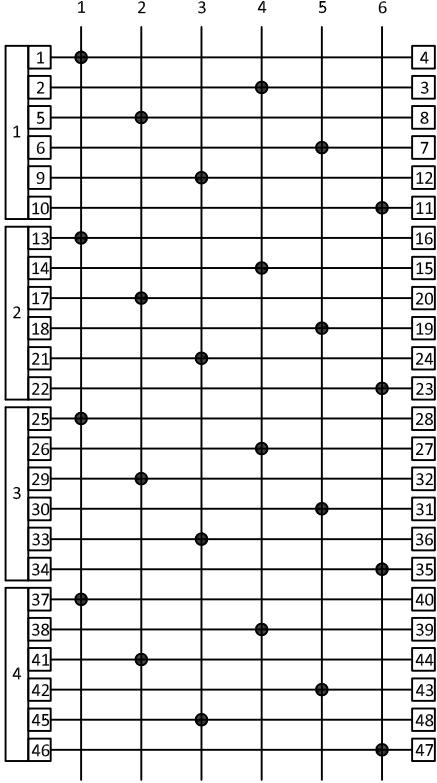
<p>1 pole 2 pole 3 pole 4 pole</p>		<p>3 6 9 12</p>	<p>603008 606008 609008 612008</p>	
--	---	-----------------------------	--	---

6 pos. switch without "0" Position, with 1 Input and 6 output per Pole.

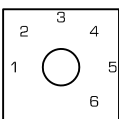
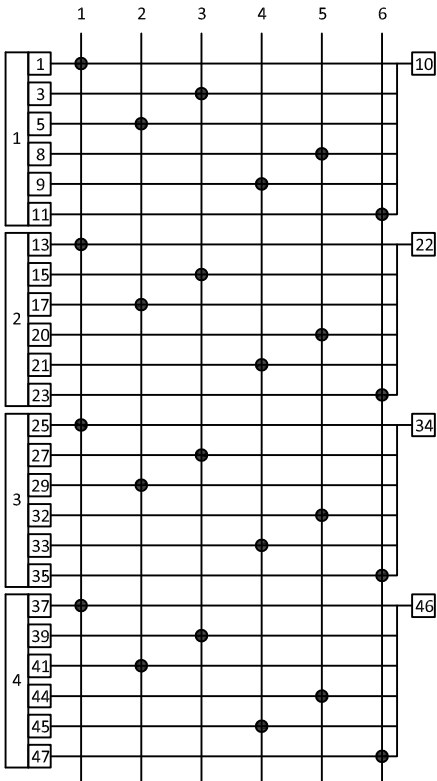
<p>1 pole 2 pole 3 pole 4 pole</p>		<p>3 6 9 12</p>	<p>603004 606004 609004 612004</p>	
--	---	-----------------------------	--	--

Switch Function and Configuration

Function	Handle Movements	Decks	Code	Connection Diagram
----------	------------------	-------	------	--------------------

7 pos. switch With "0" Position, with electrically isolated contacts.

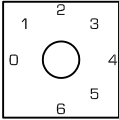
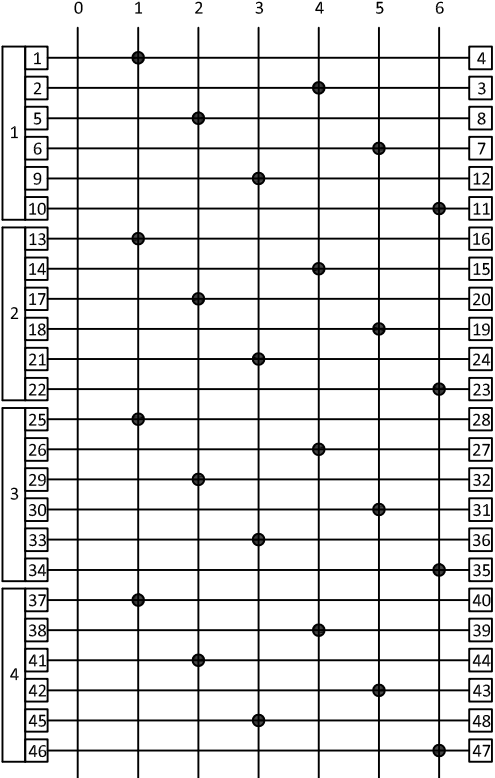
1 pole 2 pole 3 pole 4 pole		3 6 9 12	703012 706012 709012 712012	
--------------------------------------	---	-------------------	--------------------------------------	---

7 pos. switch with "0" Position, with 1 Input and 6 output per Pole.

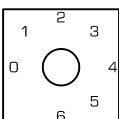
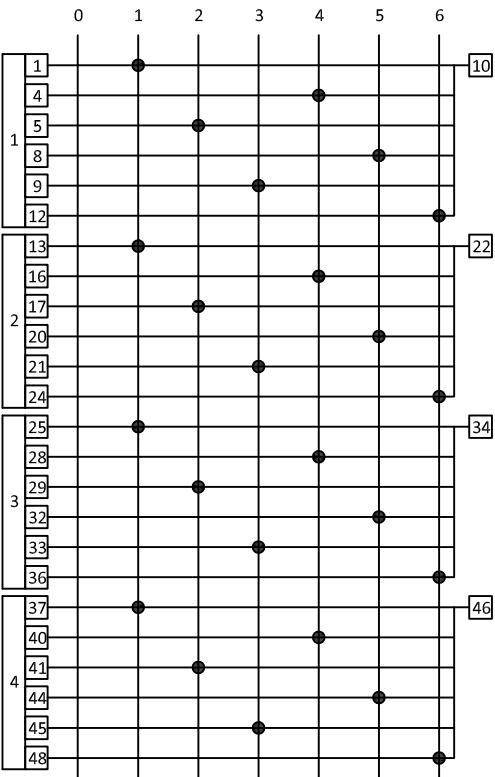
1 pole 2 pole 3 pole 4 pole		3 6 9 12	703006 706006 709006 712006	
--------------------------------------	---	-------------------	--------------------------------------	--

Switch Function and Configuration

Function	Handle Movements	Decks	Code	Connection Diagram
----------	------------------	-------	------	--------------------

7 pos. switch Without "0" Position, with electrically isolated contacts.

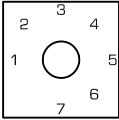
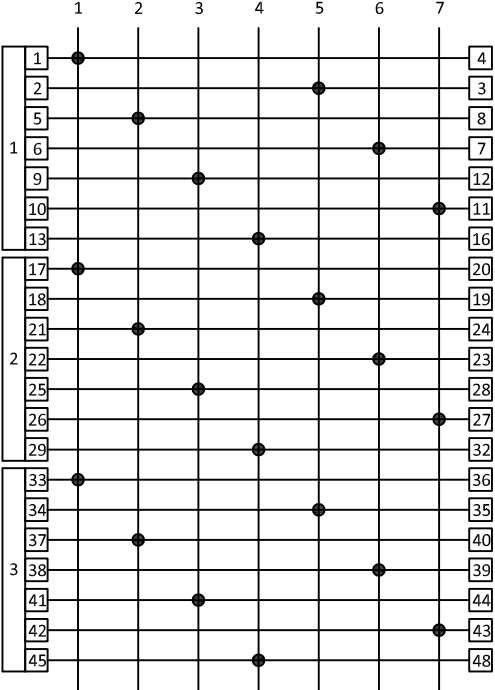
<p>1 pole 2 pole 3 pole</p>		<p>4 8 12</p>	<p>704001 708001 712001</p>	
-------------------------------------	---	-----------------------	-------------------------------------	---

7 pos. switch Without "0" Position, with 1 Input and 7 output per Pole.

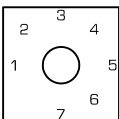
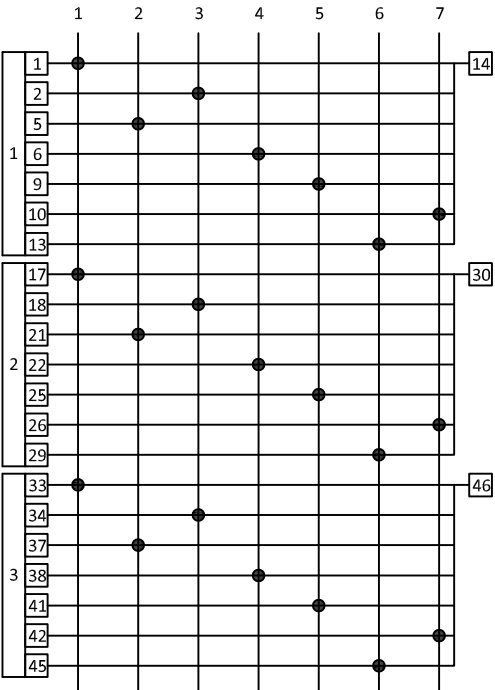
<p>1 pole 2 pole 3 pole</p>		<p>4 8 12</p>	<p>704013 708013 712013</p>	
-------------------------------------	---	-----------------------	-------------------------------------	--

Switch Function and Configuration

Function	Handle Movements	Decks	Code	Connection Diagram
----------	------------------	-------	------	--------------------

8 pos. switch With "0" Position, with electrically isolated contacts.

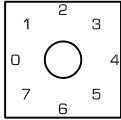
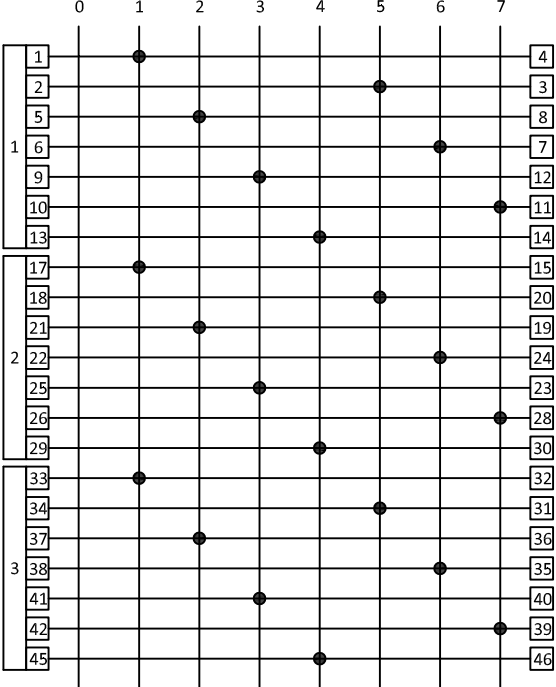
<p>1 pole 2 pole 3 pole</p>		<p>4 8 12</p>	<p>804003 808003 812003</p>	
-------------------------------------	---	-----------------------	-------------------------------------	---

8 pos. switch with "0" Position, with 1 Input and 7 output per Pole.

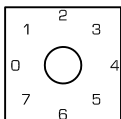
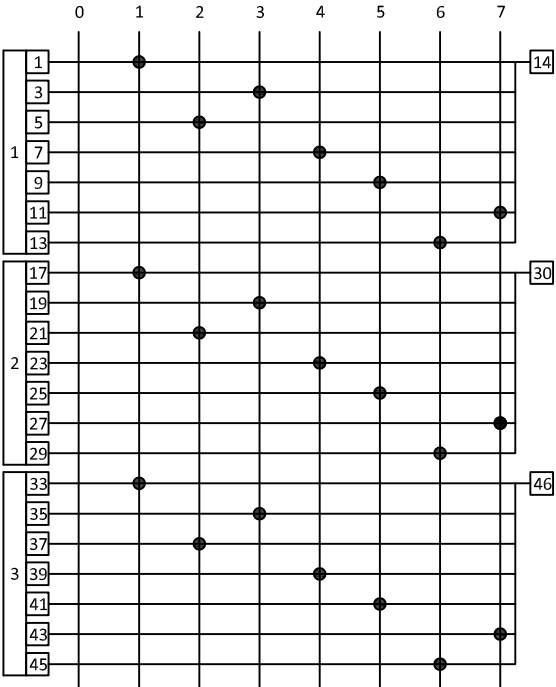
<p>1 pole 2 pole 3 pole</p>		<p>4 8 12</p>	<p>804005 808005 812005</p>	
-------------------------------------	---	-----------------------	-------------------------------------	--

Switch Function and Configuration

Function	Handle Movements	Decks	Code	Connection Diagram
----------	------------------	-------	------	--------------------

8 pos. switch Without "0" Position, with electrically isolated contacts.

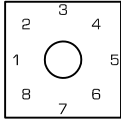
<p>1 pole 2 pole 3 pole</p>		<p>4 8 12</p>	<p>804001 808001 812001</p>	
-------------------------------------	---	-----------------------	-------------------------------------	--

8 pos. switch without "0" Position, with 1 Input and 8 output per Pole.

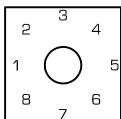
<p>1 pole 2 pole 3 pole</p>		<p>4 8 12</p>	<p>804002 808002 812002</p>	
-------------------------------------	---	-----------------------	-------------------------------------	--

Switch Function and Configuration

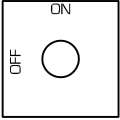
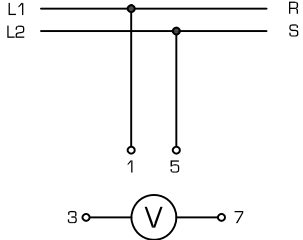
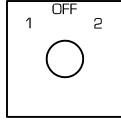
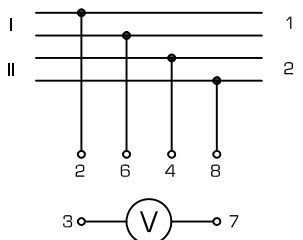
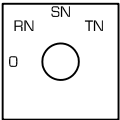
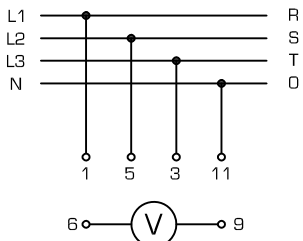
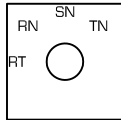
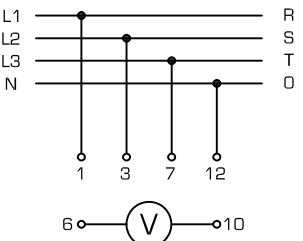
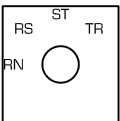
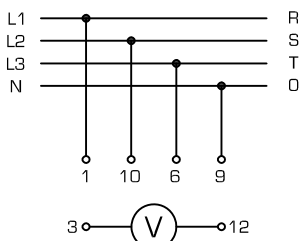
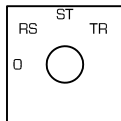
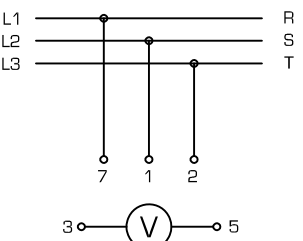
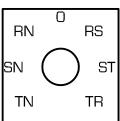
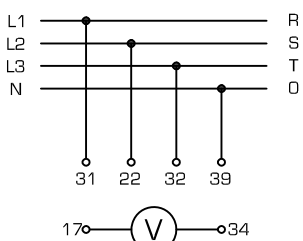
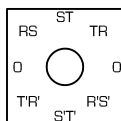
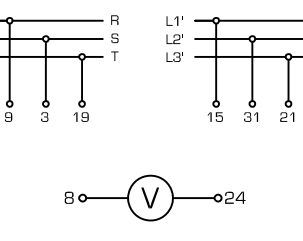
Diagram n° 202V	VOLTMETER SWITCH: 2 wire Single Phase or DC	Diagram n° 302V10	VOLTMETER SWITCH: 4 wire two Phases or two separate DC circuits
			
Diagram n° 403V15	VOLTMETER SWITCH: 3 Phase Voltage	Diagram n° 403V16	VOLTMETER SWITCH: 1 Phase to Phase and 3 phases Voltage.
			
Diagram n° 403V17	VOLTMETER SWITCH: 1 Phase Voltage and 3 Phase to Phase	Diagram n° 402V09	VOLTMETER SWITCH: 3 Phase to Phase
			
Diagram n° 705V12	VOLTMETER SWITCH: 3 Phase and 3 Phase to Phase	Diagram n° 8S08	VOLTMETER SWITCH: 3 Phase to Phase in two 3 Phase circuits.
			

Switch Function and Configuration

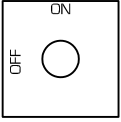
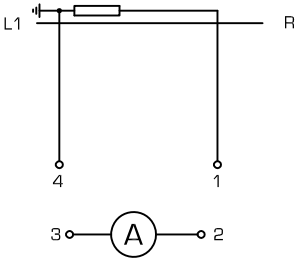
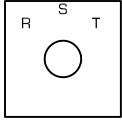
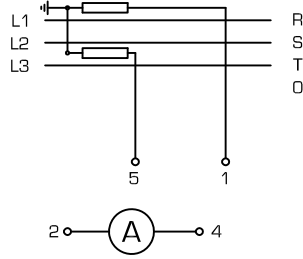
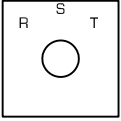
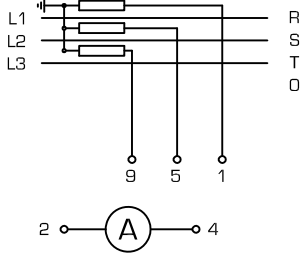
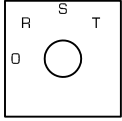
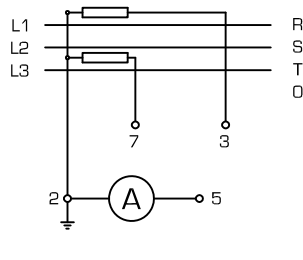
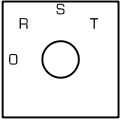
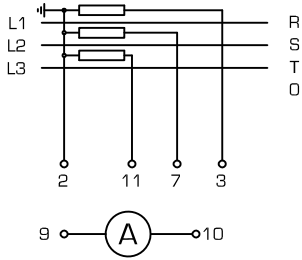
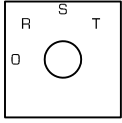
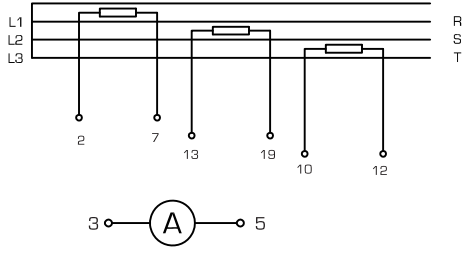
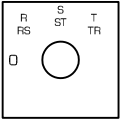
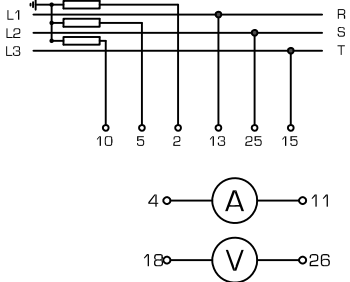
<p>Diagram n° 2G02</p>	<p>AMMETER SWITCH: 1 phase Current Transformer with "0" Pos.</p>	<p>Diagram n° 302A01</p>	<p>AMMETER SWITCH: 3 Current Measurements with 2 CT without "0"</p>
			
<p>Diagram n° 303A11</p>	<p>AMMETER SWITCH: 3 Current Measurements with 3 CT without "0"</p>	<p>Diagram n° 402A06</p>	<p>AMMETER SWITCH: 3 Current Measurements with 2 CT with "0"</p>
			
<p>Diagram n° 403A08</p>	<p>AMMETER SWITCH: 3 Current Measurements with 3 CT with "0"</p>	<p>Diagram n° 405A02</p>	<p>AMMETER SWITCH: 3 Current Measurements with 3 CT with "0" crossing Currents.</p>
			
<p>Diagram n° 407AV01</p>	<p>VOLT-AMMETER SWITCH: 3 Current Measurements with 3 CT with "0" For Voltages and Currents Measurements</p>		
			

Standard Escutcheon Plate Ordering

The Escutcheon plate is strictly necessary for fitting the switch to the panel, if none engraving is specified, the frontplate will be supplied Blank, code 00000. The engraving listed below, are only a little part of those available, require the code of the needed one if not present.

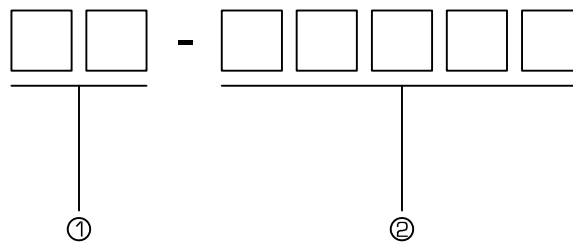

① Dimensions of the Escutcheon Plate.
Specify if 48x48mm or 64x64mm

② 2 Positions

1 0	AUT. MAN.	MAN. AUT.	AUT. MAN.	1 2	INCL. ESCL.	DIST. LOC.	2	REMOTE LOCAL	I	L R	LOC. REM.	TE TI	OFF ON
20002	20004	20006	20007	20008	20010	20012	20013	20016	20022	20028	20030	20035	20036
R L	REM. LOC.	ON OFF	AUTO	MAN.	LOC. DIST.	OFF ON	AUT.	PROVA SERVIZIO	LOC. SUPV.	EMERGENCY NEUTRAL	B A	SHIP SHORE	HAND AUTO
20037	20041	20050	20054	20055	20059	20068	20070	20106	20187	20160	20065	20085	20184
PARALLEL NEUTRAL	REM. SUPV.	MANUAL AUTO	IN OUT	TRIP ALARM	MANUAL AUTO	SERV. TRIP	NORMAL TEST	TR1 TR2	ATA ATB	MAN A MAN B	WINTER SUMMER	LOC. SCADA	OUTSGARD SHORE
20116	20404	20231	20322	20505	20463	20058	20138	20174	20196	20277	20289	20429	20341
NORMAL TRANSFER	REM. SUPV.	GS L	BYPASS SERVICE	M A	0 1	OUT IN	TRIP NORMAL	DG1 DG2	HAND AUTO	AUTO MANUAL			
20346	20404	20161	20510	20021	20001	20464	20553	20279	20152	20205			

③ 3 Positions

MAN. 0 AUT.	AUT. 0 MAN.	M 0 A	CH. 0 AP.	DIM. 0 ALUM.	AP. 0 CH.	1 0 2	TEST 0 TRIP	0 1 2	LOC. 0 DIST.	1 2 3	ALUM. 0 DIM.	OPEN 0 CLOSE	CLOSE 0 OPEN
30003	30004	30005	30010	30011	30012	30013	30014	30015	30016	30017	30019	30024	30031
A C B	START 0 STOP	TRIP 0 CLOSE	LOC. 0 REM.	LOC. 0 AUT.	2	0 MAN. AUT.	0	0	0 TRIP - CLOSE	TEST 0 STOP	EM. LOC. REM.	ON OFF TEST	RAISE 0 LOWER
30032	30050	30052	30057	30060	30082	30083	30084	30385	30085	30086	30078	30079	30087
DCS SCADA SCS	INCR. 0 DECR.	COLD 0 HEAT	G1 0 G2	A 0 B	OFF 0 ON	L 0 R	0 1 1+3	TRIP NEUTRAL CLOSE	1 OFF 2	RS ST TR	RY YB BR	R S T	R Y B
30088	30089	30090	30040	30047	30055	30062	30172	30120	30561	30630	30631	30632	30633
TEST LOC. REM.	A B C	TEST TRIP IND.	AUTO OFF MAN.	LOWER OFF RAISE	OUVRE 0 FERMÉ	LOC. REM. SUPV.	SHORE OFF GEN.	IN 0 OUT	AUTO 0 HAND	LOC. OFF REM.	TR1 PARALL TR2	T1 T1+T2 T2	MAN. LOC. REM.
30025	30114	30371	30080	30113	30154	30165	30634	30626	30635	30467	30476	30486	30192
IN NORMAL OUT	BYPASS OFF CHECK	0 L1 L2	S P M	AUTO 0 MAN.									
30609	30608	30183	30526	30108									

4 Positions														
40001	40002	40003	40004	40005	40006	40007	40008	40009	40010	40011	40012	40013	40014	
40112	40027	40017	40015	40018	40019	40021	40022	30015	40177	40023	40072	40029	40071	
40235	40019	40230	40237	40037	40056	40137	40223	40231						

5 Positions												
50001	50002	50005	50006	50048	50005	50061	50051	50062	50063	50014	50010	50064

6 Positions					
60001	60002	60015	60019	60016	60020

7 Positions		
70001	70002	70007

8 Positions								
80004	80005	80003	80001	80002	80006	80007	80008	80023

Blank
00000

Locking Programs

La linea di riferimento indica la posizione in cui il commutatore è bloccato e la chiave è estratta.
 The reference line shows where the switch is blocked and the key is withdrawn.

01	02	03	04	05	06	07	08	09	10	11	12	13	14	15	16	17	18	19
27	28																	

Form for special diagram

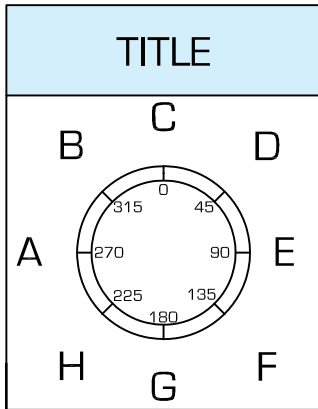

Lock in Pos.									
	Positions								
	A	B	C	D	E	F	G	H	

Contacts	A	B	C	D	E	F	G	H
1								
2								
3								
4								
5								
6								
7								
8								
9								
10								
11								
12								
13								
14								
15								
16								
17								
18								
19								
20								
21								
22								
23								
24								

Position Engraving	
Position	Engraving
TITLE	
A	
B	
C	
D	
E	
F	
G	
H	

Switch Action :

Stayput Spring return Stayput and Spring return

Specifications.....
.....

Model number:

Ordering Code : (it will provided by COMELETIC)

Accessories

Panel Mounting <input type="checkbox"/>	Pistol grip handle <input type="checkbox"/>
Base Mounting <input type="checkbox"/>	Different numbering of keys <input type="checkbox"/>
Gilded Contacts <input type="checkbox"/>	Padlockable facility <input type="checkbox"/>
IP55 Protection <input type="checkbox"/>	Electromechanical interlock <input type="checkbox"/>
Flag Mechanical indicator (only for CBCS or spring return switch) <input type="checkbox"/>	Led position indicator <input type="checkbox"/>

Wing Handle 48x48
Manopola Wing 48x48

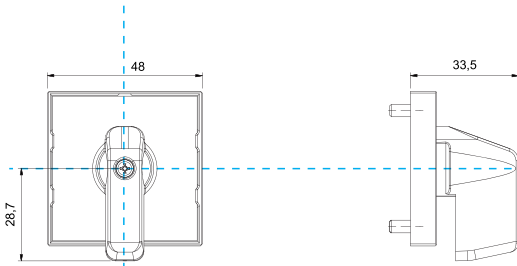

Wing Handle 64x64
Manopola Wing 64x64

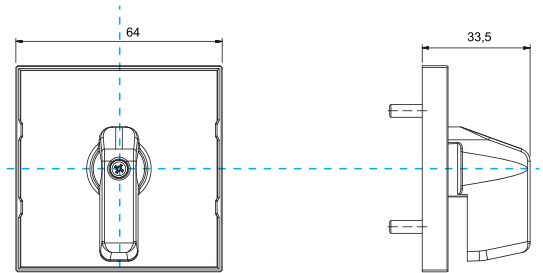

Pistol Grip Handle 48x48
Manopola Pistola 48x48

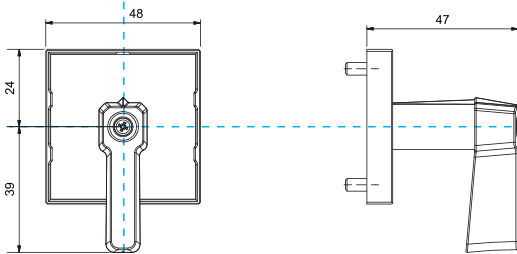

Big Pistol Grip Handle 64x64 (Trip Indicator)
Manopola Pistola Grande 64x64

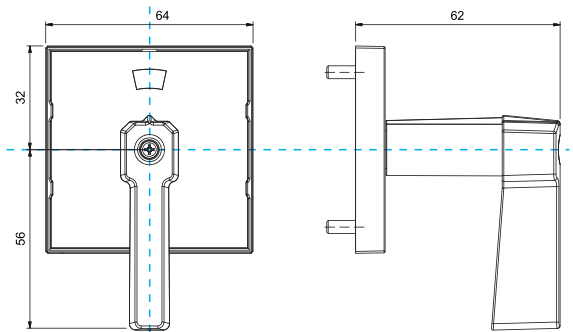

Key Operated 48x48
Operatore a Chiave 48x48

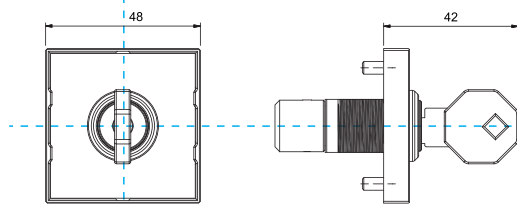

Padlockable 48x48
Manopola Lucchettabile 48x48

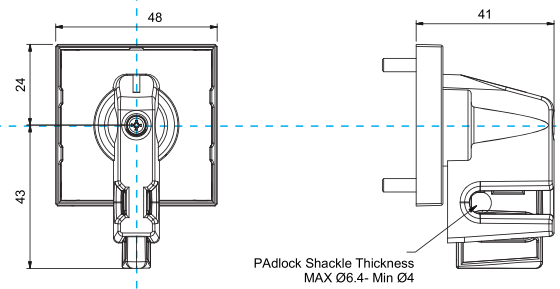

Small Padlockable 48x48
Lucchettabile Piccola 48x48

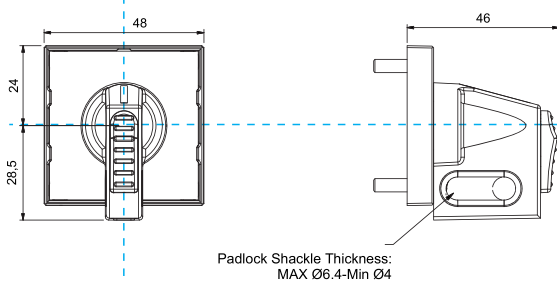

Big Oval Handle 64x64
Manopola Ovale Grande 64x64

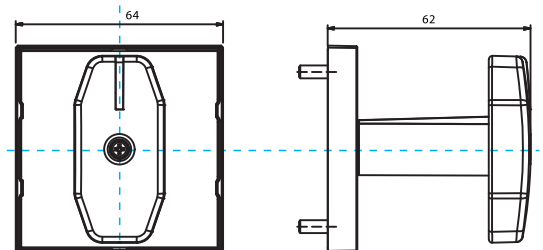

Big Pistol Grip Handle 48x48
Manopola a Pistola Grande 48x48

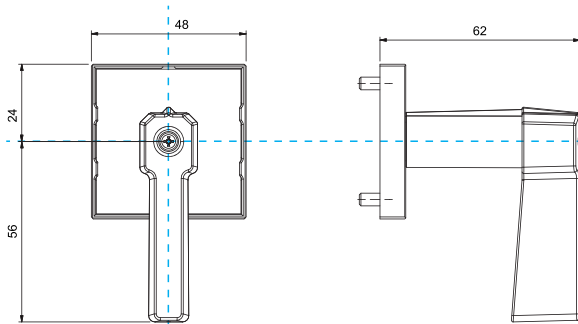

Big Padlockable Handle 64x64
Manopola Lucchettabile Grande 64x64

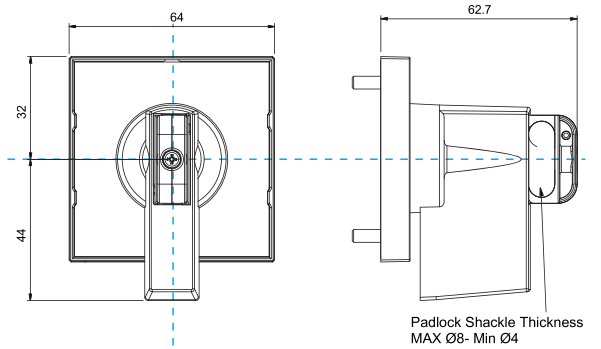

Key Operated 64x64
Operatore a Chiave 64x64

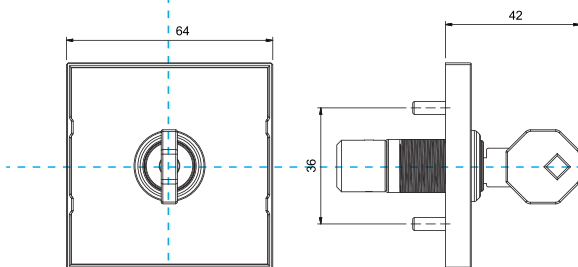

Small Oval Handle 48x48
Manopola Ovale Piccola 48x48

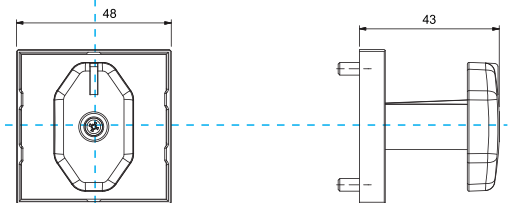

Small Pistol Grip Handle 64x64
Manopola a Pistola Piccola 64x64

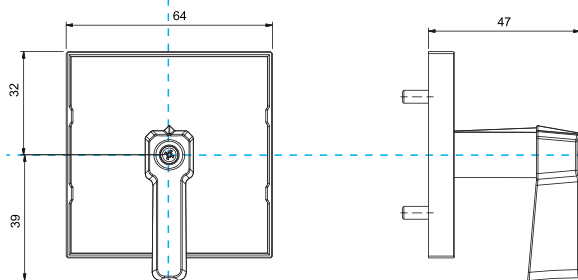

Big Padlockable Handle 64x64 (Trip Indicator)
Manopola Lucchettabile Grande 64x64

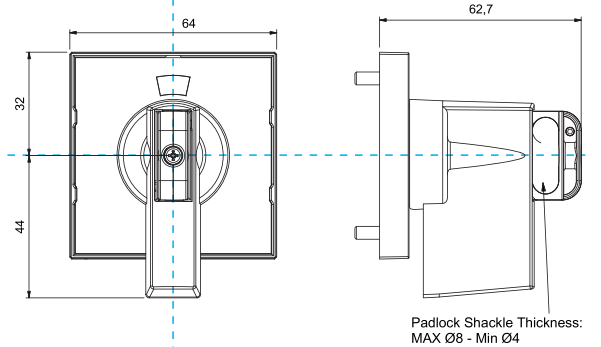

Big Oval Handle 48x48
Manopola Ovale Grande 48x48

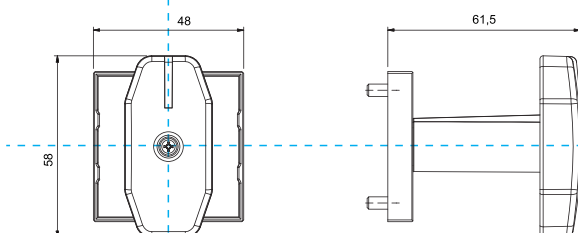

Gilded Contacts
Contatti Dorati

Description
Descrizione



To improve the reliability and the performances, even in the most aggressive environments, contacts can be supplied with special surface treatments, such as gold with thickness certificate.

Per migliorare l'affidabilità e le prestazioni anche negli ambienti più aggressivi, è possibile fornire i contatti con speciali trattamenti superficiali, con spessori Certificati (es. oro).

Legend Label
Mostrina Addizionale Titolo

Description
Descrizione



It shows the function of the switch. Available for frontplates sized mm.48x48 and mm.64x64. It does not require any extra drilling on the panel.

Indica la funzione specifica del singolo commutatore disponibile per mostrina mm.48x48 e per mostrina mm.64x64. Non necessita nessuna foratura pannello supplementare per il fissaggio.

Led Indicator
Indicatori a Led

Description
Descrizione



On demand it can be supplied with 1 or 2 LED positioned on the plate, suitable for a light indication.

Su richiesta possono essere forniti 1 o 2 indicatori LED applicati sulla mostrina da utilizzare come indicazione luminosa.

IP55 Protection
Guarnizioni IP55

Description
Descrizione



To ensure IP55 degree protection in the front of the switch, a gum plate is provided to be fitted below the frontplate Holder (not available for R308/R309).

Per assicurare il grado di protezione IP55 sul fronte del commutatore, viene fornita una guarnizione in gomma posta sotto il portamostrina (non disponibile per R308/R309).

R313 Push Button Interlock Switch
R313 Interblocco a Pulsante



The switch can be handle only by pressing the push button (2 hands operation).

Il commutatore può essere manovrato solo premendo il pulsante di blocco (operazione a 2 mani).

R310 Conductor Key Operated Switch
R310 Commutatore con Operatore a Chiave Quadra



Designed for the most renowned companies involved in railway applications. Frontpart in stainless steel, available with fix or spring return positions.

Sviluppato in collaborazione con le più rinomate aziende appositamente per applicazioni ferroviarie, frontale completamente in acciaio inox, disponibile con posizioni stabili o con molla di ritorno.

R350 Interlock Beetwen Switches
R350 Commutatori Interbloccati

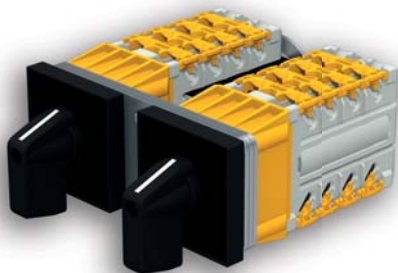

The operation of one switch is dependent from the position of the other switch.

Grazie a questo dispositivo si può bloccare l'operazione di uno dei due commutatori in relazione alla posizione dell'altro.

R301 Unidirectional Switch
S301 Rotazione Unidirezionale

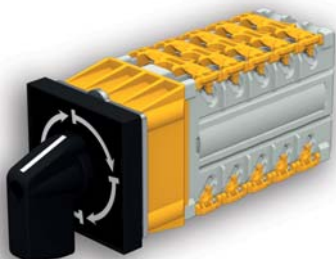

*Available for switches with 4 positions at 90° or 8 positions at 45°
It can be handled only clockwise or counterclockwise.*

*Disponibile per commutatori a 4 posizioni a 90° o 8 posizioni a 45°.
Abilita la rotazione solamente in senso orario o antiorario.*

**STANDARD UTILIZATION CATEGORIES
CATEGORIE DI UTILIZZO NORMALIZZATE**

Kind of current Tipo di corrente	Category Categoria	Typical applications Applicazioni tipiche
Alternative current Corrente alternata	AC14	Control of small electromagnetic load with rated power = 72VA Comando di piccoli carichi elettromagnetici con potenza = 72VA
	AC15	Control of electromagnetic load with rated power > 72VA Comando di carichi elettromagnetici con potenza > 72VA
Direct current Corrente continua	DC13	Control of electromagnets Comando di elettromagneti
	DC14	Control of electromagnetic loads having economy resistor in circuit Comando di carichi elettromagnetici aventi resistori economizzatori nel circuito

NORMAL CONDITIONS
CONDIZIONI NORMALI

Utilization category Categoria utilizzazione	Make Chiusura	Break Interruzione	U/Ue	COS Φ
	I/Ie	I/Ie		
AC14	6	1	1	0.3
AC15	10	1	1	0.3

ABNORMAL CONDITIONS
CONDIZIONI ANOMALE

Make Chiusura	Break Interruzione	U/Ue	COS Φ
6	6	1.1	0.7
10	10	1.1	0.3

T_{0.95} [ms]

	1	1	1	T _{0.95} [ms]
DC13	1	1	1	6xP
DC14	10	1	1	15

T_{0.95} [ms]

1.1	1.1	1.1	T _{0.95} [ms]
1.1	1.1	1.1	6xP
10	10	1.1	15

- I/Ie : Current to be made or broken and Rated operational current ratio.
Rapporto tra la corrente che l'apparecchiatura è in grado di stabilire o interrompere e la corrente d'impiego.
- U/Ue : Voltage before make and Rated operational voltage ratio.
Rapporto tra la tensione prima della chiusura e la tensione d'impiego.
- T_{0.95}: Time to reach 95% of the steady-state current.
Tempo per raggiungere il 95% della corrente di regime.
- P=Ue x Ie: Steady-state power consumption in W.
Potenza assorbita a regime in W.

The value "6xP" result from empirical relationship which is found to represent most d.c. magnetics loads to an upper limit of P =50W, i.e. 6 x P=300 ms. Load having power-consumption greater than 50W are assumed to consist of smaller loads in parallel. Therefore, 300 ms is to be an upper limits irrespective of the power. [REFERENCE STANDARD IEC 60947-5-1 tab. 5].

La relazione matematica "6xP" è valida per tutti carichi induttivi rappresentativi fino ad un massimo di P pari a 50W cioè 6xP =300ms. Si assume che i carichi aventi una potenza assorbita superiore a 50W siano costituiti da piccoli carichi collegati in parallelo, di conseguenza 300ms è il valore massimo a prescindere dalla potenza assorbita. [RIFERIMENTO NORMA IEC 60947-5-1 tab. 5]

**RATED ELECTRICAL CHARACTERISTICS
CARATTERISTICHE ELETTRICHE NOMINALI**

According to standards Conformità alle norme	IEC 60947-1 - IEC 60947-1/A1 - IEC60947-5-1 - IEC60947-5-1/A1 - EN 60947 -1/A1 - EN 60947-5-1 EN 60947-5-1/A1 - VDE 0660-100 - VDE 0660-200 - 2006/95/EC (LOW VOLTAGE DIRECTIVE), 2004/108/EC (EMC DIRECTIVE), 2011/65/EU (ROHS DIRECTIVE).	
Conventional free air thermal current Corrente convenzionale termica in aria	(I _{th})	20A
Rated insulation voltage Tensione di isolamento nominale	(U _i)	690V
Rated impulse withstand voltage Tensione di tenuta ad impulso nominale	(U _{imp})	4Kv
Frequency Frequenza di impiego		50/60Hz

**RELEVANT INFORMATION ABOUT THE ASSOCIATED SHORT CIRCUIT PROTECTIVE DEVICE
DATI RELATIVI AL DISPOSITIVO DI PROTEZIONE CONTRO IL CORTO CIRCUITO ASSOCIABILE**

Corrente di corto circuito condizionata nominale (I _{cc}) Conditional short-circuit	1000A	
Fuse Type Tipo fusibile	Gg	20A-400V
Contact resistance Resistenza di contatto	mΩ5	

**MAKING AND BREAKING CAPACITIES
POTERI DI CHIUSURA ED INTERRUZIONE**

Categoria di utilizzazione Utilization Category	(U _e)	(I _e)
AC14	400V	10A
AC15	400V	6V
DC13 L/R 50 ms	220V	1,5A
DC13 L/R ≤ 1 ms	220V	3A

**RESISTANCE TO SHOCK AND VIBRATION (IEC 61373 - CEI EN 61373 Railway applications, Rolling stock equipment)
RESISTENZA VIBRAZIONI E URTI (IEC 61373 - CEI EN 61373 Applicazioni ferroviarie, materiale rotabile).**

Vibration resistance
Resistenza alla vibrazione

Vibration Range: 5 to 150Hz, Acceleration: 5,72m/s², Time: 5h (in 3 directions)
Range di frequenza da 5 a 15Hz, Accelerazione: 5,72m/s², Tempo: 5h (in 3 direzioni)

Shock resistance
Resistenza agli urti

Acceleration: 50m/s² (in 6 directions) , Time: 30ms
Accelerazione: 50m/s² (in 6 direzioni) , Tempo: 30ms



Recommended tightening torque to avoid thread stripping
Don't exceed torque more than indicated.

Coppia di serraggio consigliata per evitare di rovinare il filetto della vite
Non superare la coppia più di quanto indicato.

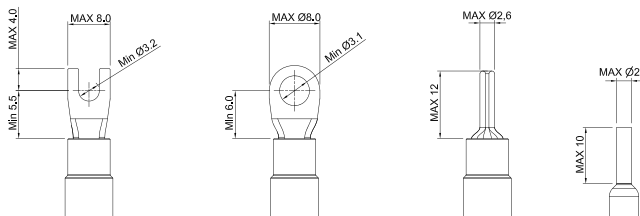

Type of conneting terminals:
Tipo di terminale utilizzabile:

Conneting screw Vite di contatto terminale		M3
Tightening torque Coppia serraggio viti	(Nm)	1.2
Permissible wire gage Sezione del conduttore		
Single - core or standed wire cavo rigido o intrecciato	(mm ²)	2 x 2.5 2 x AWG13
Flexible wire Cavo flessibile	(mm ²)	2 x 2.5 2 x AWG13

**ENVIRONMENTAL DATA (IEC 60947-1 - CEI EN 60947-1)
DATI AMBIENTALI**

Temperature range Temperatura ambientale	
Operating temperature Esercizio	-25°C +60°C
Storage temperature Stoccaggio	-40°C +80°C
Pollution degree Grado di inquinamento	PLDG 2

C-R10 12/17

Via Ernesto Rizzi 13/H
20077 Melegnano (MI) Italia
T +39 02.98119791
info@comeletric.it
P iva 00868300153

COMELETRIC.IT

