

INSTALLATION & MAINTENANCE MANUAL

PIEDMONT GROOVED-END FLEXIBLE COUPLING

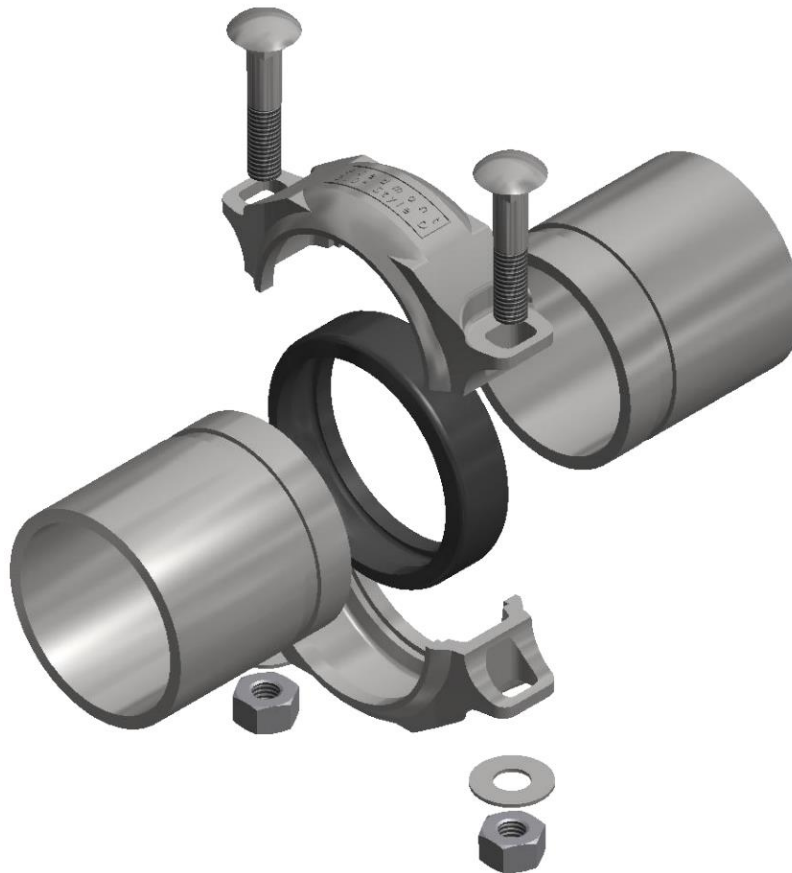

Piedmont Pacific Corporation

1048 La Mirada Court, Vista, CA 92081, United States

Phone: +1 760.305.7616, Fax: +1-760-598-2208

<http://www.piedmontpacific.com/>

TABLE OF CONTENTS

1. Introduction2

2. Coupling Components3

2.1 Coupling Housing4

2.2 Gasket5

2.3 Fasteners6

3. Installation Instructions7

3.1 Initial Preparations7

3.1.1 Pipe preparation7

3.1.2 Pipe setup8

3.1.3 Lubrication 10

3.2 Installation Steps 11

3.2.1 Groove quality inspection 11

3.2.2 Installing gasket on pipe ends 12

3.2.3 Housing installation 13

3.2.4 Fastener installation 14

3.3 Installation Inspection 16

4 Instructions for Disassembly 17

5 Maintenance and Troubleshooting 18

5.1 Probable Causes of Coupled Joint Failure and Preventive Measures 18

5.1.1 Improper installation 18

5.1.2 Wrong coupling selection 18

5.1.3 External forces and pipe misalignment 18

5.1.4 Failure due to corrosion 18

5.2 Coupling Maintenance 19

5.3 Failure Detection and Troubleshooting 19

Appendix A: Bolt Size 21

Appendix B: Cut and Roll Groove Specifications 22

Appendix C: Allowable Pipe End Separation Gaps & Deflections 28

Appendix D: Maximum Allowable Torque Values 30

Appendix E: Nonconformity Form..... 32

E.1 General Information 32

E.2 Nonconformity/Failure 32

E.3 Technical Questionnaire 33

Reference 34

1. INTRODUCTION

This manual provides important installation instructions for all Piedmont's grooved-end flexible couplings. It specifies pipe, nut and bolt requirements, coupling joint inspection, installation and maintenance procedures for couplings, and provides failure detection and troubleshooting procedures.

Awareness of the information included in this manual will assist in safe installation and long service life of the couplings; however, good judgement and proper safety practices must be followed by experienced and competent installation and supervisory personnel to prevent avoidable personal injury or equipment damage. Local health and safety regulations as well as best industry practices should also prevail.

Retain this manual for future reference, and if any doubt arises in how to execute installation and maintenance, contact Piedmont for assistance. Please also consult Piedmont for the latest version of this manual.

NOTE

- Piedmont can offer training sessions on proper flexible couplings installation. Please contact your local representative to learn more about this offer.

2. COUPLING COMPONENTS

Components of a typical coupling assembly include:

- Coupling housing: 2
- Gasket: 1
- Bolts: 2
- Nuts: 2
- Washers: 2 (on certain models only)

These components are identified in Fig. 1 and 2 for stainless steel alloy and composite plastic couplings respectively.

Figure 1: Steel Coupling Assembly (Styles K, F, B, D and S)

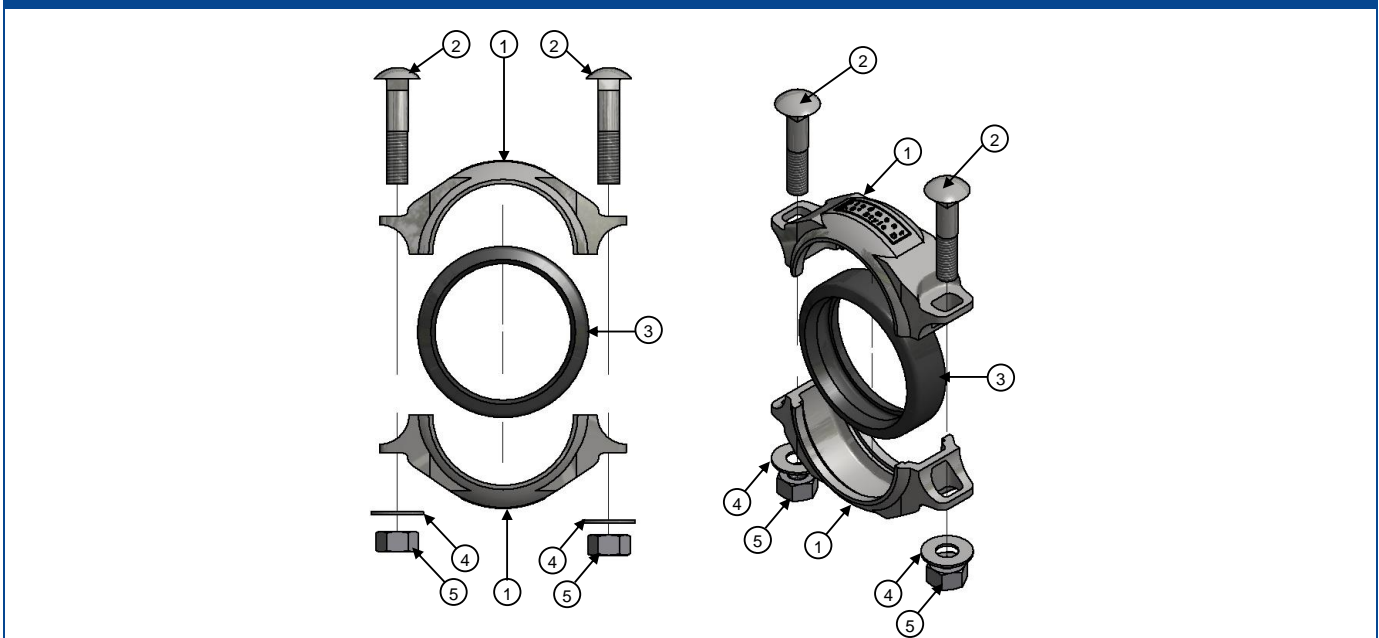

Item No.	Description	Material
1	Housing	316 (CF8M) / duplex (CE8MN) / superduplex (CE3MN / CE8MN) stainless steel
2	Round head square neck carriage bolt	316 stainless steel
3	EPDM flexible coupling gasket	EPDM
4	Flat washer (optional)	316 stainless steel
5	Hexagonal heavy nut	316 stainless steel or silicon bronze

Figure 2: Composite Coupling Assembly (Style P)

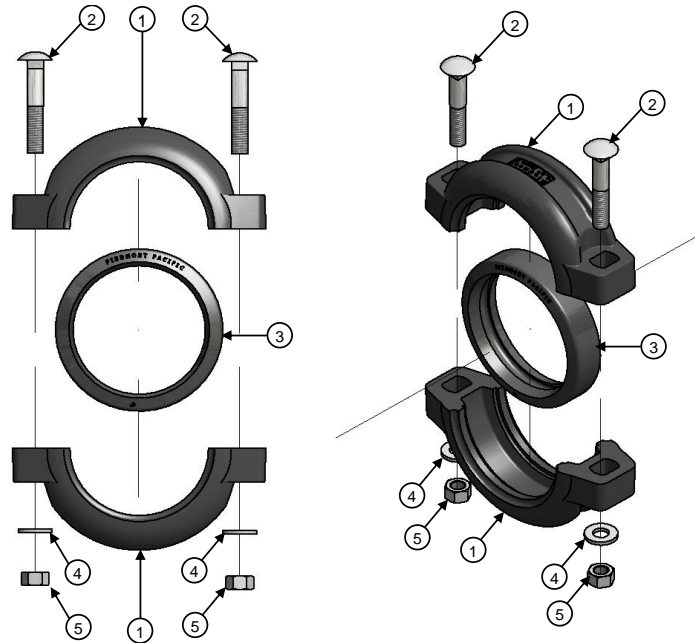

Item No.	Description	Material
1	Housing	Glass reinforced thermoplastic composite
2	Round head square neck carriage bolt	316 stainless steel
3	EPDM flexible coupling gasket	EPDM rubber
4	Flat washer	316 stainless steel
5	Hexagonal heavy nut	316 stainless steel

2.1 Coupling Housing

The coupling housing – the major structural component of a coupling assembly – is designed, manufactured and tested for specific pressure and environmental requirements. Different features of coupling housing are shown in Fig. 3.

Figure 3: Coupling Housing

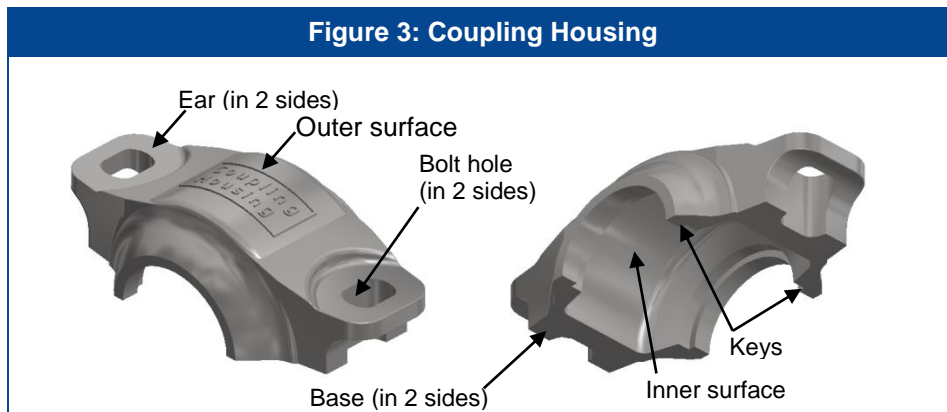
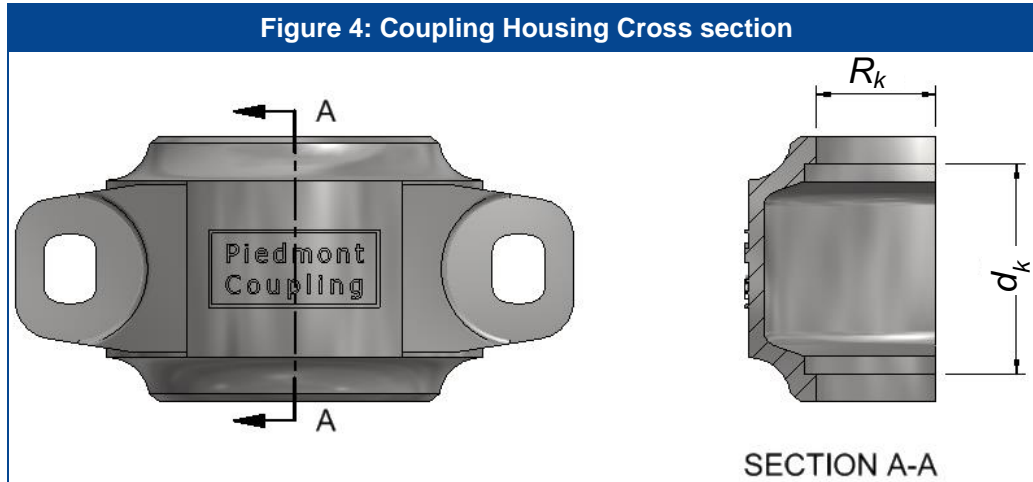

Fig.4 demonstrates the cross section of coupling housings along its width, followed by the illustrations of the exhibited dimensions. These dimensions are outlined in technical drawings of different couplings. For details visit <http://www.piedmontpacific.com/documentation>.



Dimensions	Name	Description
R_k	Key-radius	Key-radius refers to one half of the key-diameter of a coupling assembly involving 1-pair of couplings being attached together. More about groove and key diameter can be found in subsection 3.1.1 and 3.1.2 respectively.
d_k	Key-to-key distance	This dimension denotes the distance between the keys of a coupling housing. The dimension d_k determines the pipe end separation gap as well as relative angular deflection; these two parameters are detailed later in subsection 3.1.2.

Piedmont couplings are primarily categorized based on housing materials and pressure rating. Predominantly 316 (CE8M), duplex (CE8MN) and super duplex (CE8MN/CE3MN) stainless steel alloys are used for housing materials, including styles namely K, F, B, D and S. Piedmont also manufactures a corrosion resistant composite housing made of fiber glass reinforced thermoplastic resins. For more information on different styles of couplings for specific requirements – review the product data-sheet accessible at the Piedmont website (<http://www.piedmontpacific.com/>) or consult with Piedmont or your local Piedmont representative.

2.2 Gasket

The gasket is a static, radial seal. The sealing of the gasket is accomplished by the internal process pressure, forcing the two gasket lips tightly against the pipe end surface. The gland of gasket-seal reinforces and restrains its structure. It also positions the gasket between the two housing segments and the pipes to be connected.

Piedmont EPDM elastomer gaskets are ANSI 61 listed – suitable for both hot and cold water services. The normal operating temperature range of these gaskets is 10° F to 250° F (-12.2° C to 121° C). These are also compatible for minimum and maximum temperatures of -30° F (-34.4° C) and 300° F (149° C) respectively. However, continued exposure to this lowest/highest level of temperature may shorten gasket life. The EPDM elastomer is compatible with up to 2 to 3 mg/L mono-chloramine residual, many dilute acids, oil free air, and broad chemical services typically associated with water treatment and distribution systems. Both C shaped and flush-fit gaskets are available (see Fig. 5).

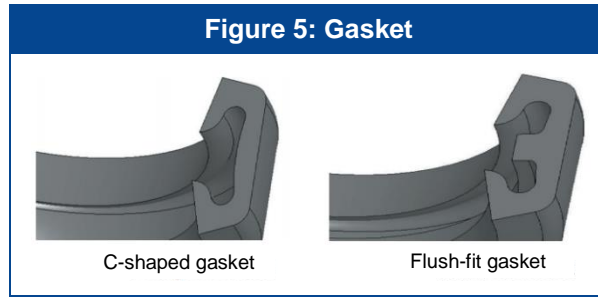

NOTE

- Expected shelf life of Piedmont gasket is 3 years – provided that – proper storage guideline was followed. The gaskets should not be over-compressed and are to be stored indoor without any direct exposure to light.
- If any doubt about ‘fit for duty’ of a gasket arises from not storing according to guidelines or stored for over 3 years, a sample gasket can be sent for testing. Contact Piedmont for details information on gasket storage and tests.
- EPDM gaskets offered by Piedmont are not suitable for petroleum and other oil containing services.
- For specific requirements, such as applications with petroleum products, hydrocarbons, air with oil vapor, vegetable and mineral oil, etc. contact your Piedmont representative.

2.3 Fasteners

The fasteners – constituting bolts, nuts and washers (if applicable) – retain the coupling housing halves together, maintaining the gasket in place for proper sealing. Piedmont uses round head, square neck 316-stainless steel carriage bolts, hexagonal nuts, and for some coupling sizes, washers based on dimensional specifications stipulated in ASME B18.5, ASEM/ANSI B18.2.2 and ASME 18.21.9 standards respectively [1-3]. For some sizes of couplings, silicon bronze nuts are standard or can be offered. See Appendix A for detailed information on bolt sizes, nuts and washer requirements.

NOTE

- Do not substitute bolts supplied by Piedmont with the bolts of different characteristics. For specific requirements for bolts for a particular application, contact Piedmont.
- Using hardware not provided by Piedmont voids the coupling assembly warranty.
- The selection of the size, material, and the tensile strength (bolt classification) is an integral and essential aspect of the coupling assembly design. Do not substitute bolts of a different size, material, or industry standard grade or classification for those supplied by Piedmont, without the explicit approval of Piedmont engineering.
- It is imperative to recognize that these properties of a bolt determine the industry standard installation torque requirement to establish the correct pretension, and this installation torque is a characteristic of the bolt. Any person who performs maintenance on the system should be able to apply the correct SAE (Society of Automotive Engineers) – or other industry – standards for installation torque value for the size and grade classification of the installed bolt.
- If any bolt is substituted by a different size, material, or grade classification the integrity of the engineering of the coupling joint is compromised, which can directly result in personal injury and equipment damage.

3. INSTALLATION INSTRUCTIONS

 <p>WARNING</p>	<ul style="list-style-type: none"> • Read all the instructions carefully prior to the installation of any Piedmont product. Noncompliance with any of these instructions may result in avoidable hazard, serious personal injury or loss of life, and/or equipment damage. • Clear understanding of the piping system’s functional requirements is essential. Select appropriate coupling to be installed for specific requirements of applications. • Piping systems must be depressurized and drained before the installation, removal and adjustment of any Piedmont products. • Wear appropriate Personal Protection Equipment (PPE). • Follow all the local health and safety regulations. • Contact your Piedmont representative should there be any doubts about the installation of Piedmont’s products.
---	--

3.1 Initial Preparations

3.1.1 Pipe preparation

As a basic preparatory step, pipes to be connected are grooved in order to accommodate the keys of coupling housing. A schematic representation of the longitudinal cross sections of a pipe segment detailing groove specifications is shown in Fig. 6, followed by the illustrations of these dimensions. Piedmont flexible couplings are designed for the application with the grooved pipes – prepared in accordance with ANSI/AWWA C606 standard [4]. Details about the groove specifications (shown in Fig. 6) can be found in Appendix B.

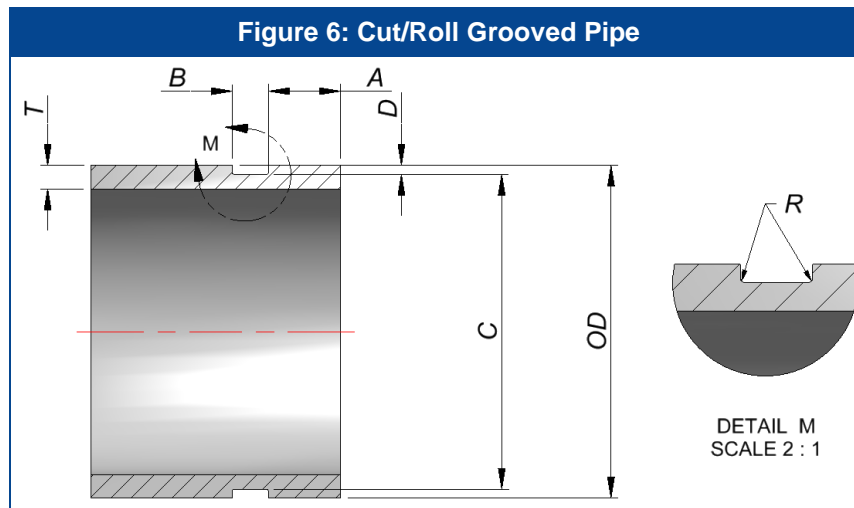

Dimensions	Dimensions name	Description
A	Gasket seat	This dimension is the distance between the pipe end and the edge of pipe groove, nearest to the pipe end. It delineates the portion of the pipe surface, where one half of the gasket is positioned and seals. The pipe surface of this seal area must be free of scoring, gouges, or indentations and free of debris, such as dirt, chips, rust, and scale that may interfere with proper gasket sealing.
B	Groove width	This dimension is the axial width of the pipe groove. The housing keys are retained by the opposing walls of this groove.
C	Groove diameter	It denotes the uniform diameter at the base of the groove, i.e. the uniform pipe outer diameter less the depth of the groove.
D	Groove depth	This is the dimension of the depth of the groove from the outermost surface of the pipe.
OD	Outer diameter	This is the uniform outer diameter of the pipe, which determines the size of the coupling to be installed.
T	Minimum pipe thickness	This thickness refers to the minimum allowable thickness for cut or roll grooves irrespective of pipe schedules
R	Radius of fillet	It represents the fillet between the groove side wall and the base surface



WARNING

- Pipe and groove dimensions must be set within the tolerances outlined in Table B.1 – B.6 in Appendix B. Noncompliance with these specifications may result in joint failures, improper and hazardous coupling installation, serious personal injury or loss of life, and/or equipment damage.
- Never coat the pipe and grooves with any products as it may modify the mechanical strength of the grooved end flexible coupling assembly.

NOTE

- Piedmont flexible couplings are tested and rated for sch. 40s or thicker pipes with cut grooved end. Consult Piedmont for the applications requiring roll grooves, thinner pipes (e.g. sch. 5s, 10s etc.) as well as pipe joints comprising two different schedules of pipes.
- Gasket seat- A must be smooth and free of indentations, roll marks, scratches, imperfections and projections from end pipe to the groove in order to provide a proper sealing surface. Dimension A is to be measured from square-cut end of pipe. Beveled end pipe is not recommended.
- The seal surfaces and bottom of the groove must be free of dirt, chips and other impurities that may interfere with the sealing or coupling assembly.
- The groove must have uniform depths (shown as D in Fig. 6) throughout the pipe circumference.

3.1.2 Pipe setup

As the next step, grooved end pipes are to be placed together in order to construct a coupled joint using a flexible coupling. The internal structure of flexible coupling allows accommodating certain pipe end separation gap and angular deflection of grooved end pipes – enabling compensation of specific pipe displacement and angular deviation – in the axial direction (see Fig. 7). Table C.1 in Appendix C outlines these parameters for various nominal sizes of couplings.

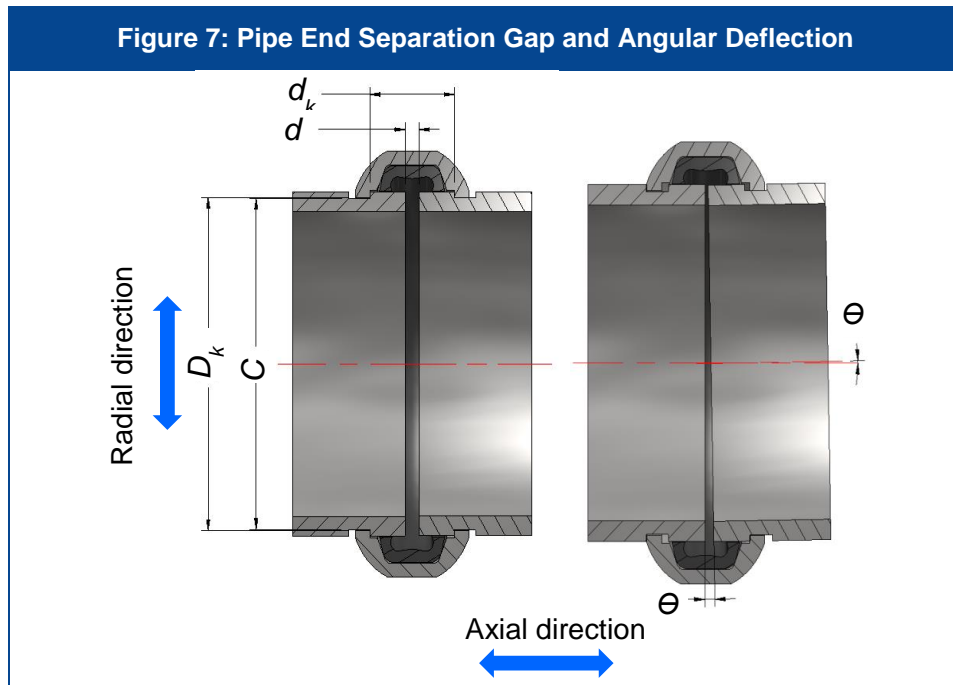

Dimensions	Dimensions name	Description
D_k	Key-diameter	Key-diameter denotes the diameter of coupling assembly involving 1 pair of couplings being attached together. The key-diameter is slightly larger than the groove diameter of pipe, enabling coupling assembly to accommodate the pipes to be connected.
C	Groove diameter	See subsection 3.1.1.
d_k	Key-to-key distance	See section 2.1.
d	Pipe end separation gap	It represents the end-to-end gap between two grooved end pipes obtainable by a single coupling assembly. This gap compensates certain level of axial displacements of corresponding pipe components.
θ	Angular deflection of pipes	This parameter designates centerline angular deflections of grooved end pipes to be connected.

Point to be noted that a single coupled joint can compensate specific pipe end separation gap and angular deflection in the axial direction, but it does not retain a significant amount of radial compliance (see Fig. 7). The key diameter (D_k) of coupling is slightly larger than the groove diameter (C) allowing coupling assembly to accommodate the circumferential surface of grooves – but it is essentially not large enough to compensate radial displacement attributed by the centerline misalignment.

By using two or more couplings, radial offset or displacement can be compensated. This phenomenon is illustrated schematically in Fig. 8 by a two-coupling configuration. This offset mechanism is attained by coupling’s ability to cohere with certain level of angular deflections of centerlines (see Fig. 7). A configuration like the one shown in Fig. 8 will compensate larger radial misalignment or displacement without inducing stress on pipes and coupled joint.

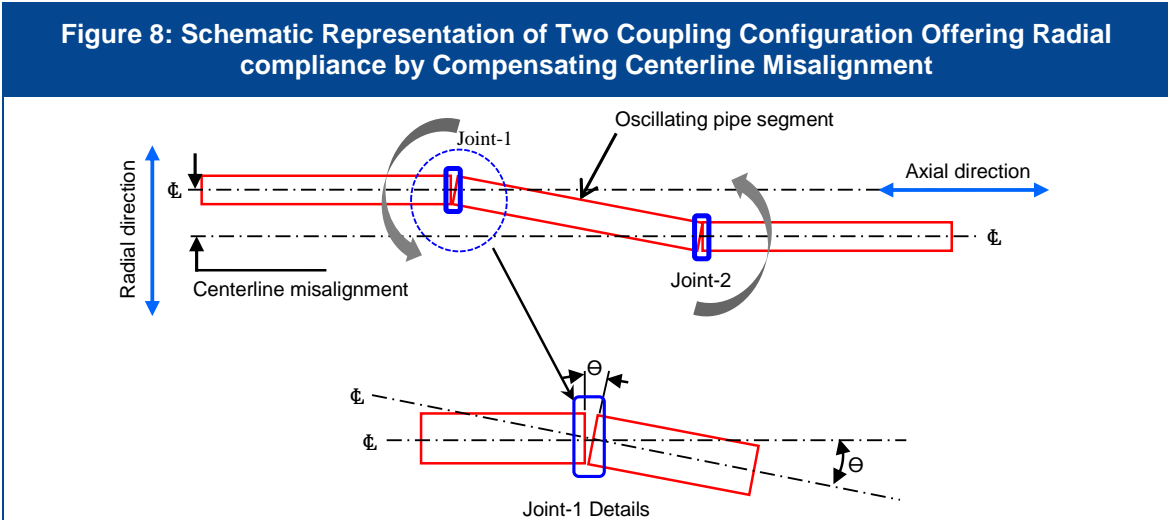

The radial displacement of pipe components could be exerted by pressure thrust resulting from pressure vessel expansions, ERD systems, axial displacement pumps, thermal expansion of pipes, and so on. In all of these applications, addition of two or more couplings reduces the risk of joint or pipework assembly failures. Furthermore, it also accommodates added axial deflection by distributing it to associated coupled joints – facilitated by the intermediate oscillating segments.

Contact Piedmont if a pipework design includes radial misalignment

3.1.3 Lubrication

Prior to the installation of coupling, outer surface of the gaskets (see Fig. 9) has to be coated with a thin layer of Piedmont lubricants. Piedmont offers a glycerine based lubricant, specifically recommended for reverse osmosis (RO) systems. Proper lubrication prevents pinching of gasket upon the closure of coupling assembly. It also facilitates accurate fitting of gasket over pipe ends avoiding unnecessary stretching.



NOTE

- Non-water soluble lubricants, namely grease, oil, wax and vegetable oil are not recommended for Piedmont products because of potential detrimental effects to RO membranes, and unintentional contamination of other equipment surfaces. Consult with membrane manufacturer for compatibility information with other lubricants.

3.2 Installation Steps

3.2.1 Groove quality inspection

Prior to the installation of coupling, a rapid test can confirm the groove quality of the pipe in perspective of appropriate engagement of coupling keys with the grooves. Note that this inspection also evaluates the ovalities of corresponding grooved end pipes.

1. Bring the grooved end sides of the pipes to be connected together. Make sure that the allowable end-to-end separation distance and angular deflection between the pipes are maintained in accordance with the Piedmont’s specifications (see Appendix C). For maximum flexibility of coupling assembly, pipes’ ends must be in contact with each other with zero end-to-end separation distance and the centerlines of the pipes be aligned resulting in zero angular deflection.

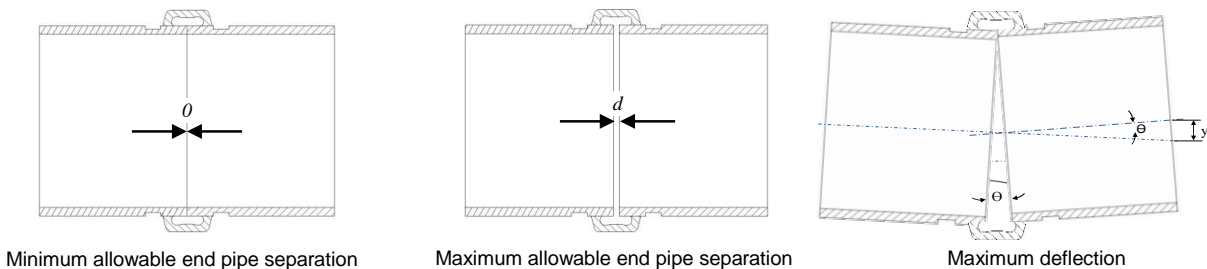



Fig. a



WARNING

- Do not exceed the allowable end pipe separation and deflection under any circumstance. Additional external deflection of piping system – resulting in deflection at the coupled joint beyond allowable limit – is not permissible. Noncompliance with this instruction may lead to improper and hazardous coupling installation, premature failure of coupling housing, serious personal injury or loss of life, and/or equipment damage.
- Select appropriate number of flexible couplings for radial displacement compliance of pipe components. Noncompliance with this instruction may lead to joint failure, serious personal injury or loss of life, and/or equipment damage.

2. Place the housing pair on the pipe joint (no gasket is required to be installed for this test). Make sure that the keys of the housings are in full engagement with the pipe grooves and bases of the housing have full contact with each other.

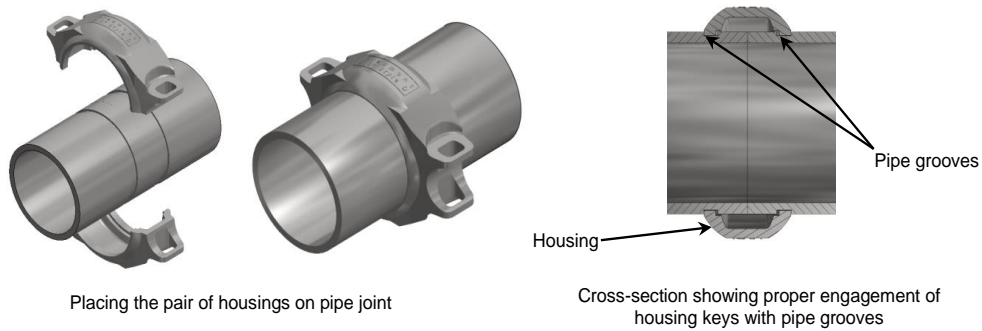

Fig. b

3. With the housing pair still placed on the pipe, rotate the coupling housings through 180° in two directions along the centerline axis by hands, as shown in Fig. c. An easy and free rotation of the housing halves, while maintaining proper engagement of keys with grooves along with metal-to-metal contact of the housing halves, will ensure proper engagement between the housing keys and corresponding pipe grooves.

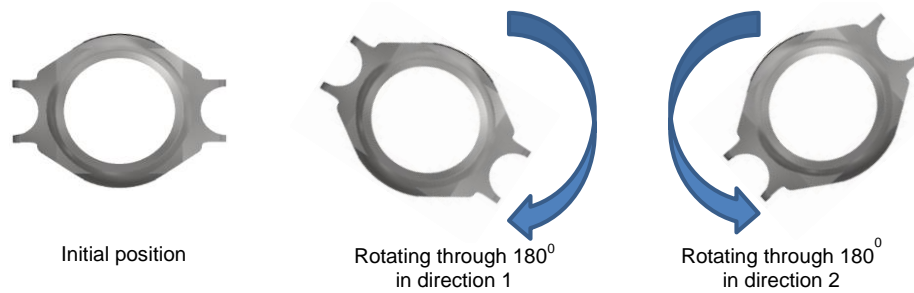

Fig. c

3.2.2 Installing gasket on pipe ends

4. Perform lubrication of the outer surface of the gaskets as discussed earlier.
5. Place the gasket over one of the grooved pipe ends and slide it over as shown in the Fig. d.

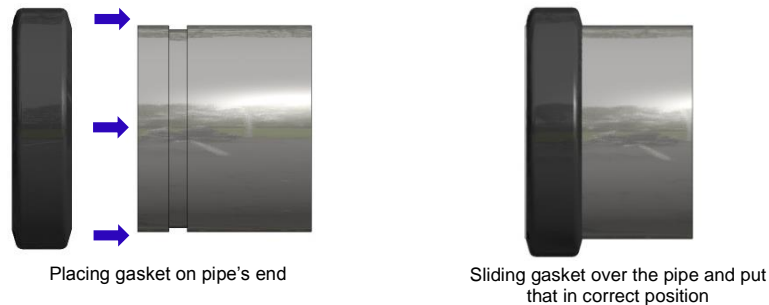

Fig. d

6. Align the two pipe ends and brings those to close proximity. Ensure proper end-to-end separation distance and angular deflection between the pipes (see Appendix C). For maximum flexibility of coupling assembly – pipes' ends must be in contact with each other and the centerlines of the pipes being aligned correctly.

- Slide the gasket to the center of the joint in such way that no portion of the gasket extends into the groove on either side. At this point both pipes are connected through the gasket as shown in Fig. e.

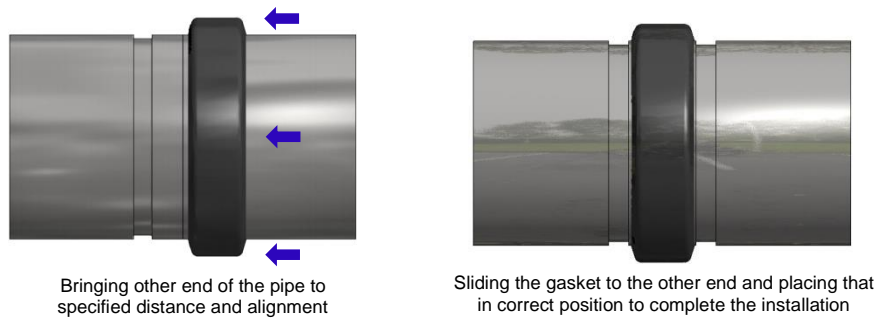

Fig. e

3.2.3 Housing installation

- Install the housing pairs on the gasket. Make sure that the keys of the housing are engaged completely with the grooves of both pipe ends (see Fig. f and g for steel and composite housing respectively).

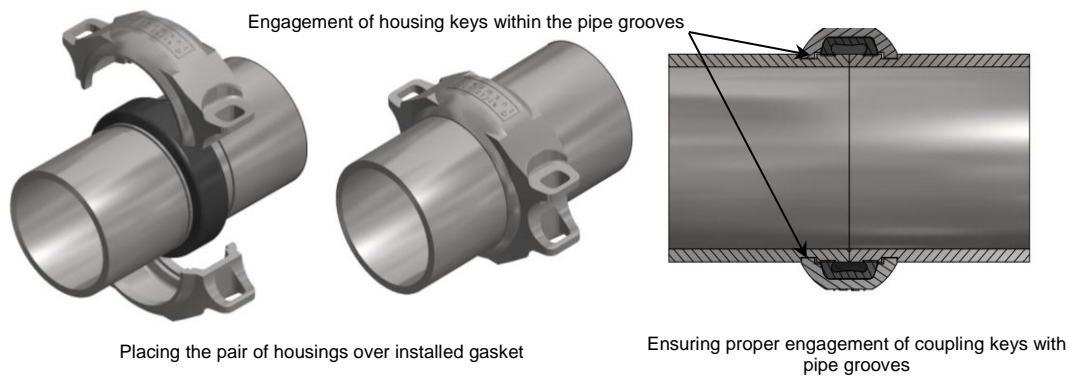

Fig. f

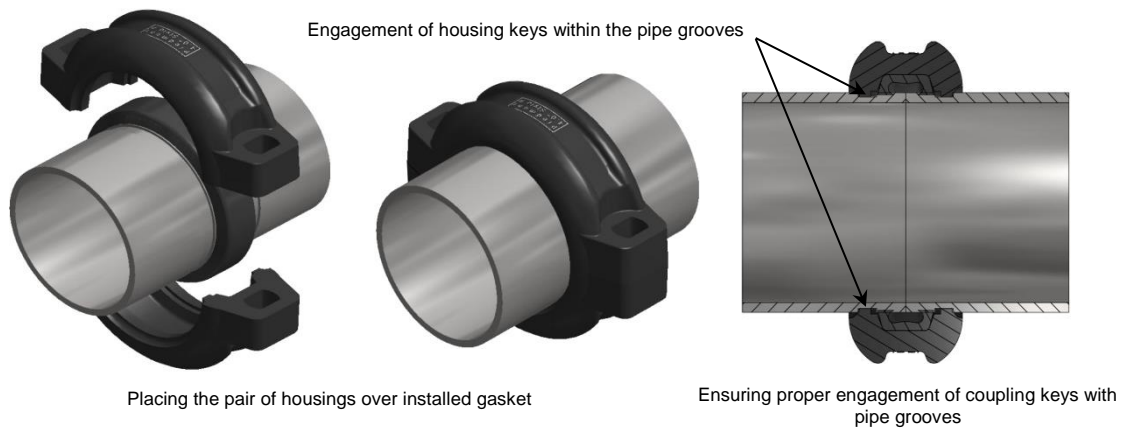

Fig. g



WARNING

Be careful not to damage the gasket by pinching or rolling while installing the housing pair. Noncompliance with this instruction may lead to gasket deteriorations causing leakages from the pipe joint.

3.2.4 Fastener installation

9. Apply anti-seize compounds on the bolt threads (unless paired with silicon bronze nuts). Insert the bolts through the bolt holes on coupling ears, place the washers (if recommended) and tighten the nuts by hands (see Fig. h).

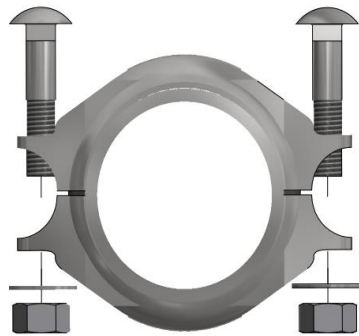

Inserting bolts in the bolt holes

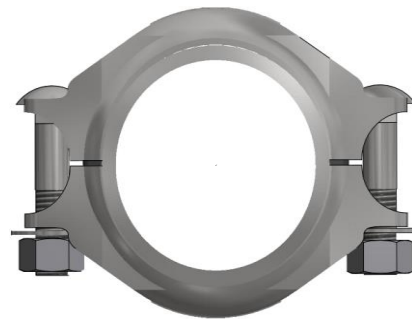

Placing washers over bolts and hand tightening of nuts

Fig. h

10. Housing pairs should fit evenly over the gasket such that the gap on each side is equal as shown in Fig. i. Complete the installation by tightening the nuts equally and evenly until the gap between the coupling housing is diminished and proper base to base contact is achieved. Use approximately 90% of the maximum torque as a general guideline. For maximum allowable torque, see Table D.1 and D.2 in Appendix D for dry and lubricated conditions respectively.

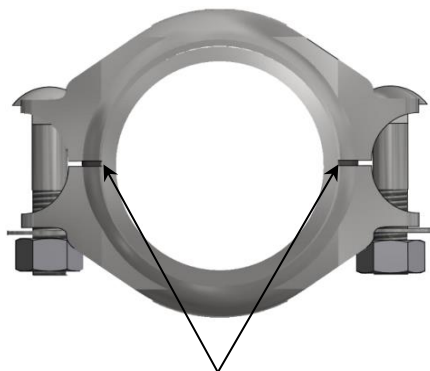

Tightening evenly and alternatively to maintain equal gaps



Final level of tightening of nuts by torque wrench to complete the installation

Fig. i

NOTE

- If stainless steel nuts are used with stainless steel bolts, commercial anti-seize compound should be applied to the mating surfaces of bolts and nuts (threads). For anti-seize compounds, Piedmont recommends molybdenum disulfide based anti-seize formulations. Contact Piedmont for details.
- Couplings with silicon-bronze nuts do not require any anti-seize compound.
- The installation torque values are selected to provide a design pretension for the bolt, and the applied torque is not a characteristic of the coupling or the flange, but rather a direct characteristic of the bolt.
- Adequate tightening torque is essential to induce sufficient bolt pretension. Too great tension can crush a gasket in a flanged piping joint, or cause non-elastic (plastic) deformation of coupling housing bolt pads, and subsequent similar deformation of the bolts themselves despite 'correct' torque application for the bolt. Too low tension will not apply the strength required by the joint despite 'correct' torque application for the bolt.

11. Same procedure is required to be followed for the installation of composite coupling (see Fig. j).



Fig. j

12. An ideally installed coupling assembly should have proper base to base contacts as shown in Fig. k.

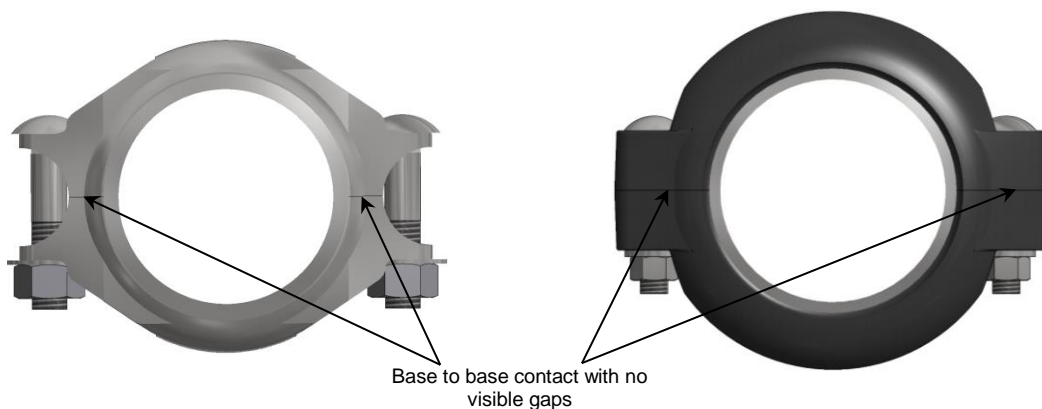

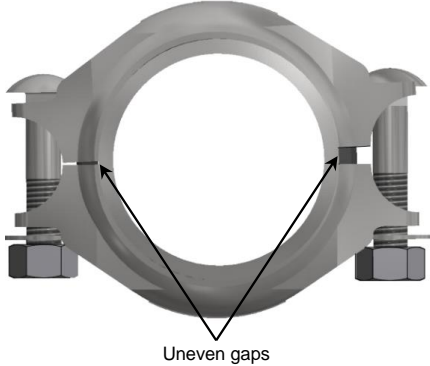
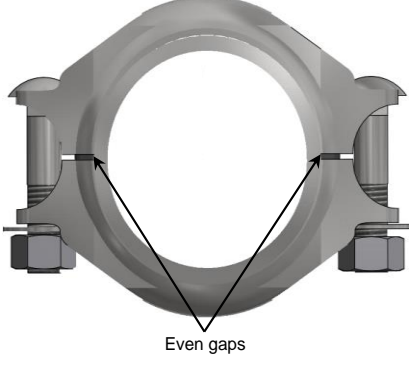



Fig. k

 WARNING	<ul style="list-style-type: none"> It is possible and normal that the housing halves bases are not completely touching over their full length. Small gaps may be seen around the mating edges of the housing pair (between the bases) or between the bolt head or nut and housing surface. As long as metal-to-metal contact is achieved and proper torque is applied, do not over-torque the assembly to try closing these small gaps Never tighten any nut to a torque value greater than the fastener ratings (see Appendix D). Over-torquing can result in permanent deformation of bolts and housings, damage to fastener threads, and compromise the integrity of the coupling assembly. Couplings must be tightened evenly and alternately. Uneven tightening – causing uneven gap – can bend bolts, pinch and cut gaskets and compromise the coupling assembly integrity. 	
	Uneven tightening ❌	Proper tightening ✅
	 Uneven gaps	 Even gaps
	<ul style="list-style-type: none"> Do not leave a partially complete installation of a coupling assembly. If a complete installation of any piping joint cannot be done, remove fasteners and couplings to eliminate the avoidable risk of incomplete assembly. Walking away from any partially assembled piping joint poses an unacceptable risk of personal injury and equipment damage from dropping hazard. 	

3.3 Installation Inspection

 WARNING	<ul style="list-style-type: none"> Inspection of the coupling joints must be carried out prior to pressurization of the system. As a general safety requirement, always perform joint inspection at depressurized state of the system. Noncompliance with this instruction may result in serious personal injury, or loss of life, and/or equipment damage. Ensure proper safety measures are taken.
---	--

After completion of installation and before running a proof test or pressurizing the system, it is important to inspect the joints in order to ensure safe and reliable services. In this context, the following conditions must be checked to ensure proper installation:

1. Ensure couplings were selected and installed as per the application requirements.
2. Pipe dimensions and groove specifications must be within the tolerances provided by Piedmont. It can be ensured by checking whether the coupling housings have proper engagement with the grooves or not.
3. Perform rigorous visual inspection to confirm gaskets are completely encapsulated by the housing pairs; housing keys are engaged fully with the pipe grooves; fasteners are correctly tightened without deformation; washers are installed (if applicable), and proper base to base contacts of housings are attained without significant visual gaps.

4 INSTRUCTIONS FOR DISASSEMBLY

 WARNING	<ul style="list-style-type: none"> • Piping systems must be depressurized and drained before attempting to remove and/or to perform adjustment of Piedmont couplings. Noncompliance this instruction may result in equipment damage, serious personal injury or loss of life. • Wear appropriate Personal Protection Equipment (PPE). • Do not leave a partially unassembled coupling to prevent drop hazard. • Follow all the local health and safety regulations.
---	---

1. After depressurizing and draining the system, untighten the nuts followed by removing the bolts (and washers if applicable). Carefully remove the housing pair. Take necessary precaution to avoid hazard that may result from dropping of housing or other coupling components.
2. Check the gasket to ensure that it is not deteriorated. Replace if necessary.
3. Check the hardware for corrosion or deformation. Replace if necessary.
4. Check the pipe and groove condition.
5. Re-assemble the system following all of the instructions depicted in the previous section.

5 MAINTENANCE AND TROUBLESHOOTING

5.1 Probable Causes of Coupled Joint Failure and Preventive Measures

Ensuring a proper installation along with correct specifications and number of couplings, accessories and pipe, will significantly reduce the chances of premature failure. However, under certain circumstance couplings can fail because of the reasons depicted in the following subsections – which also underscore corresponding preventive measures.

5.1.1 Improper installation

Premature failure commonly results from not following the installation guidelines properly, which may include using erroneous pipe and coupling grooves specifications, misalignment of coupling housing resulting from design miscalculation, improper pipe deviations, inadequate or excessive tightening torque, lack of gasket lubrication, etc.

Improper installation may result in instantaneous failure of the joint or failure over a longer period of time. For instance, bolt may be subjected to plastic deformation due to over-torquing of nuts and may experience fatigue failure or premature corrosion. On the other hand, inadequate tightening will result in insufficient clamping force required for coupling assembly to be properly functional under the operating pressure, or loosening of the nut due to system vibration.

5.1.2 Wrong coupling selection

Using a coupling for unintended applications can result in failure of the coupling joint. Examples include: using a coupling in a corrosive environment which was not made of the material rated for that particular corrosion resistivity, using a coupling in petroleum services that was rated for water service, selecting the wrong coupling size, etc.

5.1.3 External forces and pipe misalignment

It is important to be aware of external forces, which may be applied to the pipework and the couplings. Such forces will induce pipe displacements and misalignments both in axial and radial directions. Coupling failure may take place if the system was not designed to accommodate these forces and displacements. The selection of an appropriate number of couplings, maintaining proper pipe separation gaps and deflections along with their orientations are critical. Contact Piedmont for guidance on systems subjected to axial and radial displacements of pipe components joined by grooved end flexible couplings.

5.1.4 Failure due to corrosion

Corrosion agents like chloride ions are present in the humid air and the rain within a typical environment of a desalination plant near the seashore. These corrosion agents may enter in a confined zone within the coupling assembly and corresponding region may become susceptible to crevice corrosion. The condition may be further aggravated by system load and vibration. Additionally, over-tightening of fasteners may create crevice region leading to bolt failure because of synergistic effects – resulting from crevice, stress cracking and fatigue corrosion, and loads from system.

The corrosion issue may be unavoidable for a given environmental condition. However, failure resulting from corrosion may be prevented by diligent system maintenance and adequate component replacement regime in line with the severity of the environment in which the plant operates.

5.2 Coupling Maintenance

Like any other mechanical parts and components, regular maintenance of coupling ensures its reliability and maximizes the functional life-cycle along with proper operation of the entire system. The maintenance of coupling comprises of few basic tasks, including:

1. Performing visual inspections to check signs of wear, cracks, mechanical deformation, leakages and rusts (particularly the nuts and bolts, and the area of housing underneath the bolt head and washer) during routine preventive maintenance of entire system. If corrosion is evident, take appropriate actions, such as replacement of fasteners and gaskets.
2. Every year perform visual inspection of all the coupled joints. If needed disassemble the joint following Piedmont guidelines and replace the bolts. The suggestive replacement period of gaskets and fasteners is 5 years. Note that general shelf life of Piedmont gasket is 3 years.
3. Failure of bolt due to crevice corrosion can be anticipated from early signs of corrosion initiation in the visible region of bolt. Signs of corrosion in an open and aerated location – e.g. presence of small corroded spots on bolt head will almost always indicate that a more corroded region exists within the bolt.
4. The Piedmont couplings do not require any regular cleaning and changing of lubricants unless the couplings are disassembled during preventive maintenance of other components – e.g. maintenance of pumps. In such a case, follow the procedure of disassembly as depicted earlier. For reinstallation, meticulously follow the installation instructions included above. Replace any fasteners and gaskets showing visible signs of damage.

5.3 Failure Detection and Troubleshooting

Premature failure of coupling joints can be detected by means of visual clues, such as:

- Any indication of component damage.
- Presence of rust (minimum sign of rust requires parts replacement).
- Component cracks or fractures.
- Leakage.
- Gap between the installed housing segments exposing gasket.

Other than these visually observable signs, the following external signs would indicate an occurrence of potential coupling failure:

- Loss of pressure within the piping system.
- Sudden noise, indicating loss of integrity of the piping system.

In case of any of the above, the following troubleshooting steps must be carried out:

1. Turn off the plant/skid followed by depressurization of piping systems.
2. Carefully disassemble the coupling assembly following the steps mentioned earlier.
3. Check the gasket and look for any visual leakage. Also check the quality of lubricants and verify the water content for assessing contaminations resulting from the leakage of gasket.
4. Typically, nuts and bolts will fail before the housing. Therefore, check if any mechanical deformation, such as a bent bolt, is evident.
5. Look for material deformation, cracks and fractures at different locations of coupling housing, i.e. ear of the couplings (area adjacent to the socket of coupling, where the bolts are inserted), base of coupling housing, coupling keys and both internal and external surfaces.
6. Check the condition of pipe grooves for any damage and deformation.
7. Replace housing, fasteners and gaskets as needed.

8. Record the incident, complete the nonconformity form included in Appendix E, and inform Piedmont or your local Piedmont representative.



WARNING

- For any sign of failure, turn off the system immediately followed by depressurization of the system. Noncompliance with this instruction may result in equipment damage, serious personal injury or loss of life.
- For disassembly and reassembly follow all the specified instructions meticulously.

APPENDIX A: BOLT SIZE

Table A.1: Bolt Sizes and Pitch for Different Styles of Couplings						
Coupling size (inch)	Style S	Style D	Style B	Style F	Style K	Style P
	High pressure applications		Medium pressure applications		Low pressure applications	
3/4	3/8"-16 x 2"	3/8"-16 x 2"	-	5/16"-18 x 2"	5/16"-18 x 2"	5/16"-18 x 2"
1	3/8"-16 x 2"	3/8"-16 x 2"	3/8"-16 x 2"	-	5/16"-18 x 2"	5/16"-18 x 2"
1 1/4	-	3/8"-16 x 2"	3/8"-16 x 2"	5/16"-18 x 2"	5/16"-18 x 2"	5/16"-18 x 2"
1 1/2	3/8"-16 x 2"	3/8"-16 x 2"	3/8"-16 x 2"	5/16"-18 x 2"	5/16"-18 x 2"	5/16"-18 x 2"
2	1/2"-13 x 2 1/2"	1/2"-13 x 2 1/2"	3/8"-16 x 2"	5/16"-18 x 2"	5/16"-18 x 2"	5/16"-18 x 2"
2 1/2	1/2"-13 x 3"	1/2"-13 x 2 1/2"	1/2"-13 x 2 1/2"	3/8"-16 x 2"	3/8"-16 x 2"	3/8"-16 x 2"
3	1/2"-13 x 3"	1/2"-13 x 2 1/2"	1/2"-13 x 2 1/2"	3/8"-16 x 2"	3/8"-16 x 2"	3/8"-16 x 2"
4	5/8"-11 x 3 1/4"	5/8"-11 x 3 1/4"	5/8"-11 x 3 1/4"	1/2"-13 x 3"	1/2"-13 x 3"	1/2"-13 x 3"
5	-	3/4"-10 x 4 1/4"	-	-	-	-
6	-	3/4"-10 x 4 1/4"	3/4"-10 x 4 1/4"	1/2"-13 x 4"	1/2"-13 x 4"	1/2"-13 x 4"
8	-	7/8"-9 x 5"	-	5/8"-11 x 5"	5/8"-11 x 5"	1/2"-13 x 4"
10	-	1"-8 x 6 1/2"	-	5/8"-11 x 5"	5/8"-11 x 5"	-
12	-	1"-8 x 6 1/2"	-	5/8"-11 x 5"	5/8"-11 x 5"	-
14	-	1"-8 x 6 1/2"	1"-8 x 6 1/2"	1"-8 x 6 1/2"	1"-8 x 6 1/2"	-
16	-	-	-	1"-8 x 6 1/2"	1"-8 x 6 1/2"	-

NOTE

- Washers are provided and required for style D, S and P only.
- Silicon bronze nuts are provided with style S & D for coupling sizes 3/4" through 3" – inclusive.
- 316 bolts, nuts and washers are used except for the identified silicon-bronze nuts.

APPENDIX B: CUT AND ROLL GROOVE SPECIFICATIONS

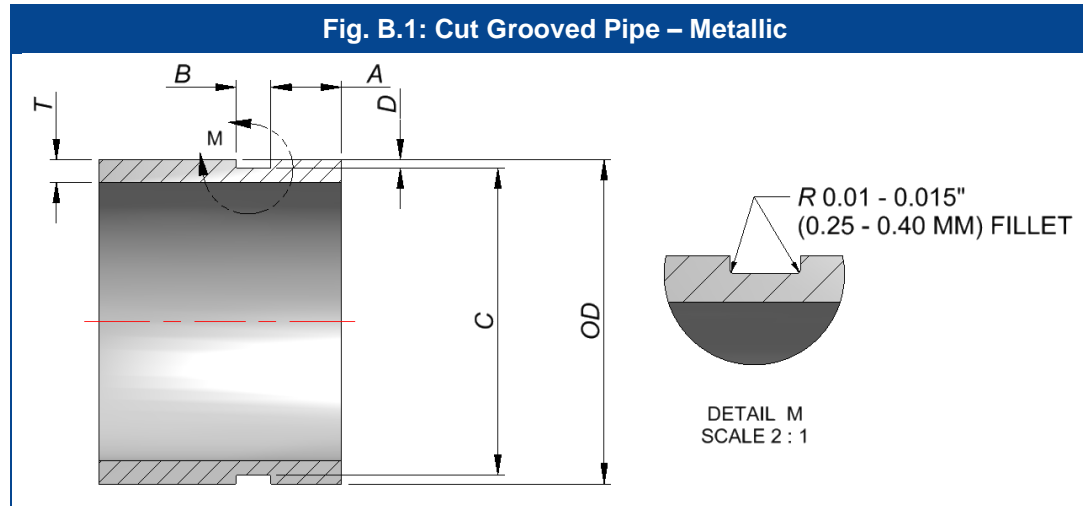

Table B.1: Cut Groove Specifications for Metallic Pipes in Standard Unit

Nominal pipe size, NPS (in.)	OD and tolerance (in.)			A (in.) (± 0.031)	B (in.) (+0.031,-0)	C (in.)		D (in.)	Min. T (in.)
	Dia.	Tol. (+)	Tol (-)			Dia.	Tol (+0)		
¾	1.050	0.010	0.010	0.625	0.312	0.938	-0.015	0.056	0.113
1	1.315	0.013	0.013	0.625	0.312	1.190	-0.015	0.063	0.133
1 ¼	1.660	0.016	0.016	0.625	0.312	1.535	-0.015	0.063	0.140
1 ½	1.900	0.019	0.019	0.625	0.312	1.775	-0.015	0.063	0.145
2	2.375	0.024	0.024	0.625	0.312	2.250	-0.015	0.063	0.154
2 ½	2.875	0.029	0.029	0.625	0.312	2.720	-0.018	0.078	0.188
3	3.500	0.035	0.031	0.625	0.312	3.344	-0.018	0.078	0.188
4	4.500	0.045	0.031	0.625	0.375	4.334	-0.020	0.083	0.203
5	5.563	0.056	0.031	0.625	0.375	5.395	-0.022	0.084	0.203
6	6.625	0.062	0.031	0.625	0.375	6.455	-0.022	0.085	0.219
8	8.625	0.062	0.031	0.750	0.438	8.441	-0.025	0.092	0.238
10	10.750	0.062	0.031	0.750	0.500	10.562	-0.027	0.094	0.250
12	12.750	0.062	0.031	0.750	0.500	12.531	-0.030	0.109	0.279
14	14.000	0.062	0.031	0.938	0.500	13.781	-0.030	0.109	0.281
16	16.000	0.062	0.031	0.938	0.500	15.781	-0.030	0.109	0.312

Table B.2: Cut Groove Specifications for Metallic Pipes in Metric Unit									
Diameter Nominal, DN (mm)	OD and tolerance (mm)			A (mm)	B (mm)	C (mm)		D (mm)	Min. T (mm)
	Dia.	Tol. (+)	Tol. (-)	(± 0.78)	(+ 0.78,-0.0)	Dia.	Tol (+0.0)		
20	26.67	0.25	0.25	15.88	7.92	23.83	-0.38	1.42	2.87
25	33.40	0.33	0.33	15.88	7.92	30.23	-0.38	1.60	3.38
32	42.16	0.41	0.41	15.88	7.92	38.99	-0.38	1.60	3.56
40	48.26	0.48	0.48	15.88	7.92	45.09	-0.38	1.60	3.68
50	60.33	0.61	0.61	15.88	7.92	57.15	-0.38	1.60	3.91
65	73.03	0.74	0.74	15.88	7.92	69.10	-0.46	1.98	4.78
80	88.90	0.89	0.79	15.88	7.92	84.94	-0.46	1.98	4.78
100	114.30	1.14	0.79	15.88	9.53	110.08	-0.51	2.11	5.16
125	141.30	1.42	0.79	15.88	9.53	137.03	-0.56	2.13	5.16
150	168.28	1.57	0.79	15.88	9.53	163.96	-0.56	2.16	5.56
200	219.08	1.57	0.79	19.05	11.13	214.40	-0.64	2.34	6.05
250	273.05	1.57	0.79	19.05	12.70	268.27	-0.69	2.39	6.35
300	323.85	1.57	0.79	19.05	12.70	318.29	-0.76	2.77	7.09
350	355.60	1.57	0.79	23.83	12.70	350.04	-0.76	2.77	7.14
400	406.40	1.57	0.79	23.83	12.70	400.84	-0.76	2.77	7.92

NOTE

- Pipe ends are to be square cut and shall be neat and free from imperfections that may affect durability, operability and safety. Metal shall be free from fins, burrs and sharp/rough edges; flame cutting is not permitted. Break all the corners with 0.01 – 0.03 inch (0.25 – 0.75 mm) chamfer unless otherwise specified. In the event of a conflict between these notes and references cited in the drawings, except for detail specifications, these notes shall take precedence.

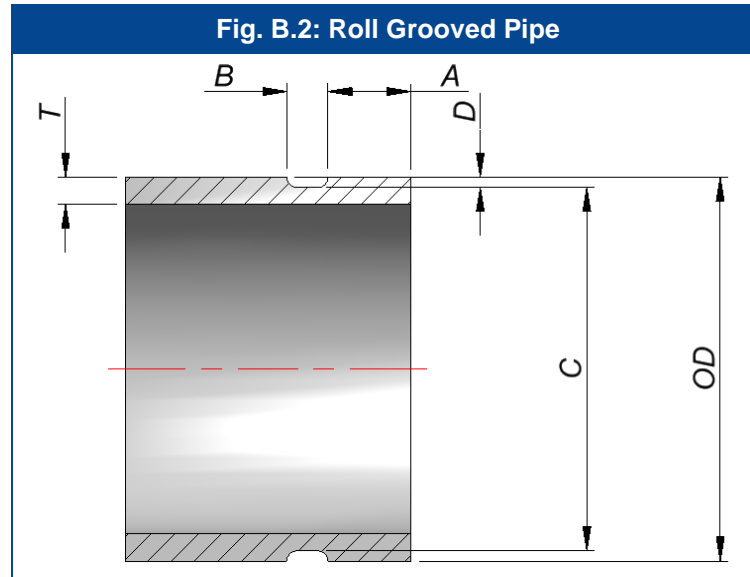

Table B.3: Roll Groove Pipe Specifications in Standard Unit

Nominal pipe size (in.)	OD and tolerance (in.)			A (in.) (+0.015, -0.030)	B (in.) (+0.031, -0.015)	C (in.)		D (in.)	Min. T (in.)
	Dia.	Tol. (+)	Tol. (-)			Dia.	Tol (+0.0)		
¾	1.050	0.010	0.010	0.625	0.281	0.938	-0.015	0.056	0.065
1	1.315	0.013	0.013	0.625	0.281	1.190	-0.015	0.063	0.065
1 ¼	1.660	0.016	0.016	0.625	0.281	1.535	-0.015	0.063	0.065
1 ½	1.900	0.016	0.016	0.625	0.281	1.775	-0.015	0.063	0.065
2	2.375	0.024	0.016	0.625	0.344	2.250	-0.015	0.063	0.065
2 ½	2.875	0.029	0.016	0.625	0.344	2.720	-0.015	0.078	0.083
3	3.500	0.030	0.018	0.625	0.344	3.344	-0.015	0.078	0.083
4	4.500	0.035	0.020	0.625	0.344	4.344	-0.015	0.083	0.083
5	5.563	0.056	0.022	0.625	0.344	5.395	-0.015	0.084	0.109
6	6.625	0.050	0.024	0.625	0.344	6.455	-0.015	0.085	0.109
8	8.625	0.050	0.024	0.750	0.469	8.441	-0.020	0.092	0.109
10	10.750	0.050	0.025	0.750	0.469	10.562	-0.025	0.094	0.134
12	12.750	0.050	0.025	0.750	0.469	12.531	-0.025	0.109	0.156
14	14.000	0.060	0.025	0.938	0.469	13.781	-0.025	0.109	0.156
16	16.000	0.060	0.025	0.938	0.469	15.781	-0.025	0.109	0.165

Table B.4: Roll Groove Pipe Specifications in Metric Unit									
Diameter Nominal, DN (mm)	OD and tolerance (mm)			A (mm) (+0.015, -0.030)	B (mm) (+0.031, -0.015)	C (mm)		D (mm)	Min. T (mm)
	Dia.	Tol. (+)	Tol (-)			Dia.	Tol (+0.0)		
20	26.67	0.25	0.25	15.88	7.14	23.83	-0.38	1.42	1.65
25	33.40	0.33	0.33	15.88	7.14	30.23	-0.38	1.60	1.65
32	42.16	0.41	0.41	15.88	7.14	38.99	-0.38	1.60	1.65
40	48.26	0.41	0.41	15.88	7.14	45.09	-0.38	1.60	1.65
50	60.33	0.61	0.41	15.88	8.74	57.15	-0.38	1.60	1.65
65	73.03	0.74	0.41	15.88	8.74	69.09	-0.38	1.98	2.11
80	88.90	0.76	0.46	15.88	8.74	84.94	-0.38	1.98	2.11
100	114.30	0.89	0.51	15.88	8.74	110.34	-0.38	2.11	2.11
125	141.30	1.42	0.56	15.88	8.74	137.03	-0.38	2.13	2.77
150	168.28	1.27	0.61	15.88	8.74	163.96	-0.38	2.16	2.77
200	219.08	1.27	0.61	19.05	11.91	214.40	-0.51	2.34	2.77
250	273.05	1.27	0.64	19.05	11.91	268.27	-0.64	2.39	3.40
300	323.85	1.27	0.64	19.05	11.91	318.29	-0.64	2.77	3.96
350	355.60	1.52	0.64	23.83	11.91	350.04	-0.64	2.77	3.96
400	406.40	1.52	0.64	23.83	11.91	400.84	-0.64	2.77	4.19

NOTE

- Pipe ends must be neat and free from imperfections that may affect durability, operability and safety. Metal shall be free from fins, burrs and sharp/rough edges; flame cutting is not permitted. Break all corners with 0.01 – 0.03 inch (0.25 – 0.76 mm) chamfer unless otherwise specified. In the event of a conflict between these notes and references cited in the drawings, except for detail specifications, these notes shall take precedence.

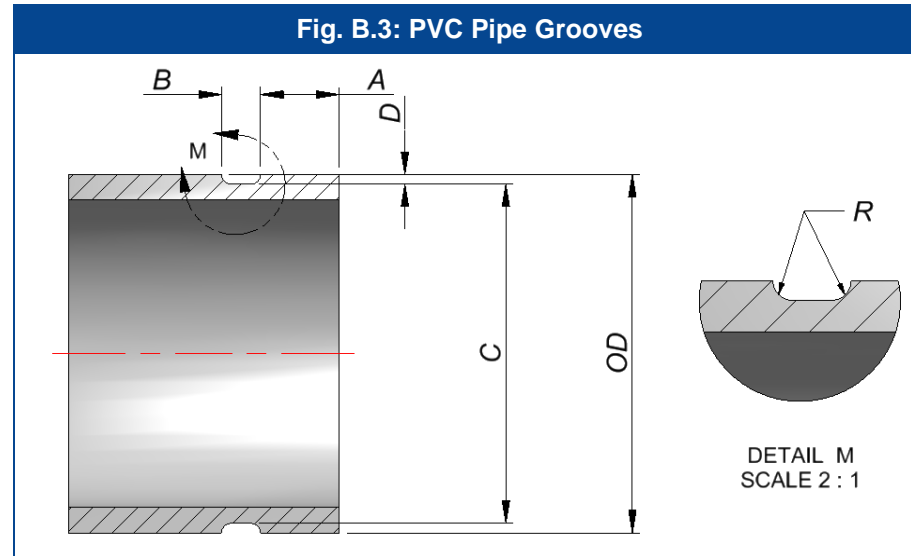

Table B.5: PVC Pipe Groove Specifications in Standard Unit

Nominal pipe size, NPS (in.)	OD (in.)	A (in.) (± 0.032)	B (in.) (± 0.032)	C (in.)		D (in.)	R (in)
				Dia.	Tol (+0)		
¾	1.050	0.625	0.312	0.938	-0.015	0.056	0.056
1	1.315	0.625	0.312	1.190	-0.015	0.063	0.062
1 ¼	1.660	0.625	0.312	1.535	-0.015	0.063	0.062
1 ½	1.900	0.625	0.312	1.775	-0.015	0.063	0.062
2	2.375	0.625	0.312	2.250	-0.015	0.063	0.062
2 ½	2.875	0.625	0.312	2.720	-0.018	0.078	0.078
3	3.500	0.625	0.312	3.344	-0.018	0.078	0.078
4	4.500	0.625	0.375	4.334	-0.020	0.083	0.083
5	5.563	0.625	0.375	5.395	-0.022	0.084	0.083
6	6.625	0.625	0.375	6.455	-0.022	0.085	0.085
8	8.625	0.750	0.438	8.441	-0.025	0.092	0.092
10	10.750	0.750	0.500	10.562	-0.027	0.094	0.094
12	12.750	0.750	0.500	12.531	-0.030	0.109	0.109
14	14.000	0.938	0.500	13.781	-0.030	0.109	0.109
16	16.000	0.938	0.500	15.781	-0.030	0.109	0.109

Table B.6: PVC Pipe Groove Specifications in Metric Unit

Diameter Nominal, DN (mm)	OD (mm)	A (mm) (± 0.78)	B (mm) (± 0.78)	C (mm)		D (mm)	R (mm)
				Dia.	Tol (+0)		
20	26.67	15.88	7.92	23.83	-0.38	1.42	1.42
25	33.40	15.88	7.92	30.23	-0.38	1.60	1.57
32	42.16	15.88	7.92	38.99	-0.38	1.60	1.57
40	48.26	15.88	7.92	45.09	-0.38	1.60	1.57
50	60.33	15.88	7.92	57.15	-0.38	1.60	1.57
65	73.03	15.88	7.92	69.10	-0.46	7.70	1.98
80	88.90	15.88	7.92	84.94	-0.46	1.98	1.98
100	114.30	15.88	9.53	110.08	-0.51	2.11	2.11
125	141.30	15.88	9.53	137.03	-0.56	2.13	2.11
150	168.28	15.88	9.53	163.96	-0.56	2.16	2.16
200	219.08	19.05	11.13	214.40	-0.64	2.34	2.34
250	273.05	19.05	12.70	268.27	-0.69	2.39	2.39
300	323.85	19.05	12.70	318.29	-0.76	2.79	2.77
350	355.60	23.83	12.70	350.04	-0.76	2.77	2.77
400	406.40	23.83	12.70	400.84	-0.76	2.79	2.77

NOTE

- Pipe ends must be neat and free from imperfections, dents, cracks, which may affect durability, operability and safety. In the event of a conflict between these notes and references cited in the drawings, except for detail specifications, these notes shall take precedence.

APPENDIX C: ALLOWABLE PIPE END SEPARATION GAPS & DEFLECTIONS

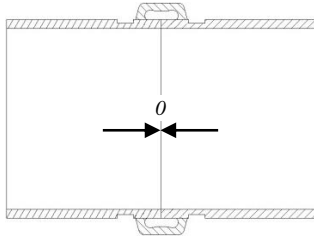

Minimum allowable end pipe separation

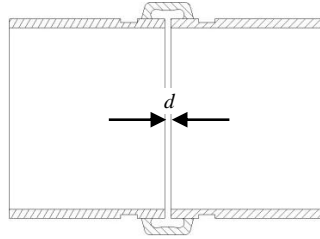

Maximum allowable end pipe separation

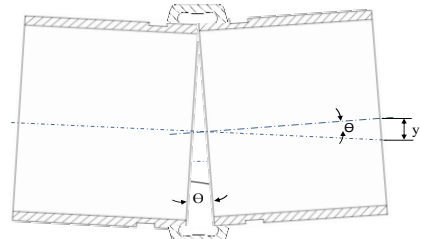

Maximum deflection

Table C.1: Allowable Pipe End Separations and Deflections

NPS (inch) DN (mm)	Maximum allowable pipe end separation (inch) (mm)		Maximum deflection	
	Cut grooves	Roll grooves	θ (degree)	y (inch/ft) (mm/m)
¾ 20	0.10 2.53	0.06 1.60	3.44°	0.72 60
1 25	0.12 2.94	0.06 1.60	2.72°	0.57 48
1 ¼ 32	0.10 2.53	0.06 1.60	2.15°	0.45 38
1 ½ 40	0.10 2.53	0.06 1.60	1.91°	0.40 33
2 50	0.10 2.53	0.06 1.60	1.53°	0.32 27
2 ½ 65	0.10 2.53	0.06 1.60	1.24°	0.26 22
3 80	0.10 2.53	0.06 1.60	1.05°	0.22 18
4 100	0.25 6.40	0.13 3.20	1.62°	0.34 28
5 125	0.25 6.34	0.13 3.20	1.32°	0.27 22
6 150	0.25 6.40	0.13 3.20	1.10°	0.23 19
8 200	0.25 6.40	0.13 3.20	0.86°	0.18 15
10 250	0.25 6.40	0.13 3.20	0.62°	0.13 11
12 300	0.25 6.40	0.13 3.20	0.53°	0.11 9
14 350	0.25 6.40	0.13 3.20	0.74°	0.15 13
16 400	0.294 7.44	0.18 4.57	0.64°	0.14 11

NOTE

- The allowable pipe end separation gaps and angular deflections are applicable for cut/roll grooved metallic pipes – prepared as per Piedmont Pacific groove pipe specifications.
- End separation gaps presented in Table C.1 are applicable for nominal values of pipe gasket seat dimension and coupling key-to-key to distance. Contact Piedmont for higher requirement of end separation gaps.
- The angular deflections are calculated based on maximum allowable separation gaps for roll grooves. For higher angular deflections, consult with Piedmont.
- Gasket seat dimension is to be measured from square-cut end of pipe. Beveled end pipe is not recommended.
- Pipe ends are to be square cut, shall be neat and free from imperfections that may affect durability, operability and safety. Pipe structure shall be free from fins, burrs and sharp/rough edges; flame cutting is not permitted.

APPENDIX D: MAXIMUM ALLOWABLE TORQUE VALUES

Table D.1: Torque Values for Dry Conditions						
NPS (inch) DN (mm)	Torque (ft.lb) (N.m)					
	Style S	Style D	Style B	Style F	Style K	Style P
¾ 20	18.0 24.0	18.0 24.0	-	11.0 15.0	11.0 15.0	5.0 7.0
1 25	18.0 24.0	18.0 24.0	20.0 27.0	-	11.0 15.0	5.0 7.0
1 ¼ 32	-	18.0 24.0	20.0 27.0	11.0 15.0	11.0 15.0	5.0 7.0
1 ½ 40	18.0 24.0	18.0 24.0	20.0 27.0	11.0 15.0	11.0 15.0	5.0 7.0
2 50	40.0 54.0	40.0 54.0	20.0 27.0	11.0 15.0	11.0 15.0	5.0 7.0
2 ½ 65	40.0 54.0	40.0 54.0	45.0 61.0	20.0 27.0	20.0 27.0	7.5 10.0
3 80	40.0 54.0	40.0 54.0	45.0 61.0	20.0 27.0	20.0 27.0	7.5 10.0
4 100	96.0 130.0	96.0 130.0	96.0 130.0	45.0 61.0	45.0 61.0	10.0 14.0
5 125	-	131.0 177.0	-	-	-	-
6 150	-	131.0 177.0	131.0 177.0	45.0 61.0	45.0 61.0	10.0 14.0
8 200	-	202.0 273.0	-	96.0 130.0	96.0 130.0	10.0 14.0
10 250	-	299.0 405.0	-	96.0 130.0	96.0 130.0	-
12 300	-	299.0 405.0	-	96.0 130.0	96.0 130.0	-
14 350	-	299.0 405.0	299.0 405.0	299.0 405.0	299.0 405.0	-
16 400	-	-	-	299.0 405.0	299.0 405.0	-

Table D.2: Torque Values for Lubricated Conditions

NPS (inch) DN (mm)	Torque (ft.lb) (N.m)					
	Style S	Style D	Style B	Style F	Style K	Style P
¾ 20	N/A	N/A	-	10.0 14.0	10.0 14.0	5.0 7.0
1 25	N/A	N/A	17.0 23.0	-	10.0 14.0	5.0 7.0
1 ¼ 32	-	N/A	17.0 23.0	10.0 14.0	10.0 14.0	5.0 7.0
1 ½ 40	N/A	N/A	17.0 23.0	10.0 14.0	10.0 14.0	5.0 7.0
2 50	N/A	N/A	17.0 23.0	10.0 14.0	10.0 14.0	5.0 7.0
2 ½ 65	N/A	N/A	38.0 51.0	17.0 23.0	17.0 23.0	7.5 10.0
3 80	N/A	N/A	38.0 51.0	17.0 23.0	17.0 23.0	7.5 10.0
4 100	82.0 111.0	82.0 111.0	82.0 111.0	38.0 51.0	38.0 51.0	10.0 14.0
5 125	-	111.0 150.0	-	-	-	-
6 150	-	111.0 150.0	111.0 150.0	38.0 51.0	38.0 51.0	10.0 14.0
8 200	-	172.0 233.0	-	82.0 111.0	82.0 111.0	10.0 14.0
10 250	-	254.0 344.0	-	82.0 111.0	82.0 111.0	-
12 300	-	254.0 344.0	-	82.0 111.0	82.0 111.0	-
14 350	-	254.0 344.0	254.0 344.0	254.0 344.0	254.0 344.0	-
16 400	-	-	-	254.0 344.0	254.0 344.0	-

APPENDIX E: NONCONFORMITY FORM

The client should complete the nonconformity form for any occurrence of coupling failure. Please use an additional page if the space below is not adequate. Additional references, pictures and documents can be added to this form accordingly. A proper investigation to determine the root cause may require more information.

E.1 General Information

Client's name		Date	
Project Name (if applicable)		PO No. / SO No.	

E.2 Nonconformity/Failure

Coupling style (s) and sizes		Quantities (specify separately for different styles)	
Description of the defect/failure			

E.3 Technical Questionnaire

<p>Operating pressure:</p> <p>Stipulate the operating pressures of the failed component(s).</p>	
<p>Installation time-line :</p> <p>State how long the coupling(s) was operational after installation, before the failure took place.</p>	
<p>Installation information:</p> <p>Specify about installation torque</p>	
<p>Type of water and environmental condition:</p> <p>Describe briefly the type of water (seawater, brackish water, wastewater, etc.), and environmental condition (corrosive, acidic, etc.)</p>	
<p>Location of coupled joint:</p> <p>Specify the location of the joint that failed with respect to overall system. Identify any major system components (if applicable), such as: axial piston pumps, ERD device, pressure vessels, etc. adjacent to the coupled joint. Please use proper description along with pictures and required system diagrams.</p>	

REFERENCE

- [1.] ASME B18.5-2012, Round Head Bolts (Inch Series).
- [2.] ASME/ANSI 18.2.2 -1987, Square and Hex Nuts (Inch Series).
- [3.] ASME 18.21.1 - 2009, Washers: Helical Spring-Lock, Tooth Lock, and Plain Washers (Inch Series).
- [4.] ANSI/AWWA C606 -2011, Standard for Grooved and Shouldered Joints.

Piedmont



Headquarters: 54/18 Bui Quang La, Ward 12, Go Vap District, HCMC, Viet Nam
Office: 12 DHT10B, Dong Hung Thuan Ward, District 12, HCMC, Viet Nam
Phone: (028) 6258 5368 - (028) 6291 9568
Email: info@atswatertechnology.com
Website: www.atswatertechnology.com

© 2016 Piedmont Pacific Corporation. All Rights Reserved.

Released Date: July, 2016 – Revision 1.10