

AMIAD Water Systems Ltd.

48" AGF PRO Automatic Media Filter System

Serial number:	_____
Order number:	_____
Catalog number:	_____
Tested by:	_____

Installation, Operation and Maintenance Instructions

Ref. 910101-001049 / 03.2022
Original Instructions

AMIAD Water Systems Ltd.

48" AGF PRO Automatic Media Filter System



Disclaimer:

Copyright © 2018 Amiad Water Systems Ltd. All rights reserved.

The contents of this document, including without limitation all information and materials, images, illustrations, data, drawings, names and any other such materials that appear in this document are the sole property of Amiad Water Systems Ltd. ("Amiad"), including any intellectual property rights, whether registered or not, and all know-how contained or embodied therein (together the "Content"). Amiad may alter, remove or change the Content without any further notice. You may not reproduce, copy, modify, create derivative works from, sell or participate in any sale of, or exploit in any way, in whole or in part, any of this document or its Content.

The confidential nature of and/or privilege in the file enclosed is not waived or lost as a result of a mistake or error in this file. If you received this file in error, please notify Amiad immediately at info@amiad.com.

This document does not replace any certified drawing, procedure or information provided by Amiad in reference to a specific customer, site or project.

Amiad assumes that all users understand risks involved within this file and/or its attached materials. This document is given in good faith and is not intended to impose any obligation to Amiad. While every effort has been made to ensure the information in this manual is accurate and complete, we would appreciate if you can bring any errors or omissions to the knowledge of Amiad or consult Amiad experts or its authorized representatives if you have any questions.

Amiad Water Systems Ltd. D.N. Galil Elyon 1, 1233500, Israel Tel: 972 4 690 9500 | Fax: 972 4 814 1159 Email: info@amiad.com

Table of Contents

- TECHNICAL SPECIFICATIONS 4**
 - 1. GENERAL4
 - 2. BACKWASHING DATA4
 - 3. CONSTRUCTION MATERIALS.....4
 - 4. FILTRATION MEDIA TYPE.....5
 - 5. SILICA SAND / GRAVEL DATA.....5
- SAFETY INSTRUCTIONS..... 6**
 - 6. GENERAL SAFETY INSTRUCTIONS.....6
 - 7. INSTALLATION SAFETY INSTRUCTIONS6
 - 8. COMMISSIONING SAFETY INSTRUCTIONS.....8
 - 9. OPERATION AND CONTROL SAFETY INSTRUCTIONS.....8
 - 10. MAINTENANCE SAFETY INSTRUCTIONS.....8
- DIMENSIONAL DRAWING 10**
 - 1. MEDIA FILTERS.....11
 - 2. HOW THE AGF PRO FILTERS OPERATE.....11
 - 3. THE FILTRATION PROCESS.....12
 - 4. THE BACKWASH PROCESS.....12
- INSTALLATION 13**
 - 1. PRE INSTALLATION13
 - 2. FILTER ASSEMBLY.....13
 - 3. LEAKAGE TEST - BEFORE FILLING THE MEDIA14
 - 4. FILLING-UP THE MEDIA.....14
 - 5. INITIAL OPERATION14
- MAINTENANCE 15**
 - 1. GENERAL INSPECTION15
 - 2. PERIODIC INSPECTION15
 - 3. ANNUAL INSPECTION15
 - 4. REPLACING THE MEDIA.....15
- TROUBLESHOOTING 16**
- AGF PRO FILTER PARTS LIST 18**
- PARTS DRAWING 19**
- AMIAD LIMITED WARRANTY 20**

With any inquiry, please quote Filter Serial Number, located on the filter housing.

Technical Specifications

1. General

Filter tank diameter	1,220 mm	48"	
Inlet/Outlet diameter	110 mm	4" grooved	Flange standards per request.
Maximum operating pressure	6 bar	85 psi	For ambient temperature (25 C)
Minimum operating pressure during filtration mode	1.4 bar	20 psi	
Minimum pressure on the downstream manifold during backwash mode	2 bar	30 psi	
Max. operating temp.	50°C	122°F	
Flow rate range (single filter)	10-80 m ³ /h	44-352 gpm	Depends on the type of media in the filter, filtration degree & water quality.
Vessel Volume	780 liter	206 US gallons	
Filtration surface area	1.13 m ²	12.16 ft ²	
Filter Weight (Empty – Filter only)	132 kg	291 lbs.	
Approx. media weight	730 Kg	1606 lbs.	
Water Weight	370 Kg	814 lbs.	

2. Backwashing Data

Backwash valve	110 mm	4"	
Backwashing cycle time	2 – 4 hours	2 – 4 hours	
Backwashing time (single unit)	90-120 seconds	90- 120 seconds	
Backwashing water consumption per 1 cycle (single unit)	1330-2000 liter	351-528 US gallon	Depends on the actual backwash time
Backwashing flow rate	40-60 m ³ /h	155-180 US gpm	

3. Construction Materials

Manifolds	Polypropylene
Filter housing	Polyethylene coated by glass flakes and resin
Media	PEP Active (Glass media) / Quartz / Gravel
Backwash valves	Reinforced Polyamide
Distribution Nozzles	Polypropylene
Seals	EPDM

4. Filtration Media Type

Media Type	Quartz			PEP Active (Glass media)		Gravel
Grade	0	1	2	0	1	1
Size	0.5 - 0.8 mm	0.8 - 1.2 mm	1.2 - 2.0 mm	0.25 – 0.5 mm	0.5 - 1.1 mm	0.8 - 1.2 mm
	0.019-0.031 inch	0.031-0.047 inch	0.047-0.078 inch	0.01098 - 0.019 inch	0.019 - 0.043 inch	0.031-0.047 inch
Approx. media weight	730kg / 1606 lbs. (Depending media type)					

Recommended no of media bags (approx.)			
Media Composition	No. of media bags	Media bag size	
		kg	lbs.
Gravel 1	28	25	55
Quartz 2* + PEP Active	14 + 14	25	55
Quartz 2* + Quartz 0	14 + 14	25	55

*quartz 2 is a support layer of coarse media, spread below distribution nozzles "Dead area"

5. Silica Sand / Gravel Data

Media Type	Mesh range	Average Effective Size Gravel	
		mm	inch
Crushed Silica 12	80-130	1.1 - 1.2	0.043-0.047
Crushed Silica 16	155-200	0.6 – 0.7	0.023-0.275
Crushed Silica 20	170-230	0.45 – 0.5	0.017-0.019

Safety Instructions

6. General Safety Instructions

1. Amiad filtration products always operate as components in a larger system. It is essential for the system designers, installers and operators to comply with all the relevant safety standards.
2. Prior to installation, operation, maintenance or any other type of action carried out on the filter, read carefully the safety, installation and operation instructions.
3. During installation, operation or maintenance of the filter all conventional safety instructions should be observed in order to avoid danger to the workers, the public or to property in the vicinity.
4. Please note: The filter enters a Backwashing mode automatically, without an early warning.
5. No change or modification to the equipment is permitted without a written notification given in advance by the manufacturer or by its representative, on the manufacturer's behalf.
6. Always observe standard safety instructions and good engineering practices whilst working in the filter's vicinity.
7. Use the filter only for its intended use as designed by Amiad, any misuse of the filter may lead to undesired damage and may affect your warranty coverage. Please consult with Amiad prior to any non-regular use of this equipment.

7. Installation Safety Instructions

General

1. Install the filter according to the detailed Installation Instructions provided with the filter by the manufacturer and according to the description given in this manual.
2. Make sure to leave enough clearance to enable easy access for future treatments and safe maintenance operations.
3. The user should arrange suitable lighting at the area of the filter to enable good visibility and safe maintenance.
4. The user should arrange suitable platforms, ladders, and safety barriers to enable easy and safe access to the filter without climbing on pipes and other equipment. The user should verify that any platform, barrier, ladder, or other such equipment is built, installed, and used in accordance with the relevant local authorized standards.
5. Check and re-tighten all bolts during commissioning and after the first week of operation.
6. Use only appropriate standard tools and equipment operated by qualified operators when installing, operating, and maintaining the filter.
7. When installation is required in hazardous environment sites, underground or high above ground, make sure that the site design and the auxiliary equipment are appropriate and that installation procedures are carried out in accordance with the relevant standards and regulations.
8. Ensure walking areas about the installation are slip free when wet.

Shipment and transporting

1. Shipping and transporting the filter must be done in a safe and stable manner and in accordance with the relevant standards and regulations.
2. For shipping, lifting and positioning the filter, use only approved lifting equipment and authorized employees and contractors.

Electricity

1. Electric wiring should be performed by an authorized electrician only, using standardized and approved components.
2. Install a lockable main power cut-off switch close to the control panel.
3. If due to site constraints, the control panel is installed without a clear line-of sight of the filter, an additional lockable power disconnect cut-off switch should be installed near each filter unit.
4. Installation of the filter should be performed so as to avoid direct water splashing on the electrical components or on the control panel.

Pneumatics

1. Install a **lockable** main cut-off switch, **featured with a pressure release mechanism**, on the compressed air supply line close to the control panel.
2. If the control panel is installed far away and there is no eye contact with the filter, a lockable compressed air cut-off switch, featured with a **pressure release mechanism**, should be installed near each filter unit.
3. The user should make sure that the compressed air supplied to the filter never exceeds the maximum designated pressure for this filter.
4. An air-pressure reduction valve should be installed on the compressed air supply line upstream of the filter's pneumatic inlet port.

Hydraulics

1. Extra safety devices should be installed on hot water applications to avoid skin burn danger.
2. The user should install a manual Water Cut-off Valve next to the filter's inlet port.
3. In cases where the downstream piping network downstream of the filter is pressurized an additional manual Water Cut-off Valve should be installed next to the filter outlet port.
4. The user should make sure that the system includes a Pressure Release / Drainage Valve to enable release of residual pressure prior to any maintenance procedure performed on the filter.
5. The user should make sure that the filter is never exposed to water pressure exceeding the maximum designated pressure for this filter, if needed a Pressure Reduction Valve should be installed upstream of the filter's water inlet port.
6. Please note that the maximum working pressure indicated at the filter's specifications table includes the pressure caused by fluid hammer and pressure surge effects.

Civil Engineering

1. Make sure that the filter installation is done by Amiad qualified technicians.
2. Make sure that any civil engineering work at the installation site such as construction, lifting, welding, etc. is done by qualified workers / technicians / contractors and in accordance with the relevant local standards.
3. While using lifting equipment, make sure that the filter or the lifted part is chained securely and in a safe manner.
4. Do not leave lifted equipment if there is no necessity. Avoid working below lifted equipment.
5. Wear a safety helmet while using lifting equipment.
6. Make sure that the flooring is sloped for drainage, and to avoid accumulation of liquids.

8. Commissioning Safety Instructions

1. Read carefully the Commissioning and the First Start-up Operation instructions prior to any attempt to operate the filter.
2. In order to achieve maximum performance and smooth operation of the filter it is crucial to perform the Startup and First Operation procedures exactly as described in this manual.
3. Commissioning the filter should be done by an authorized Amiad technician, do not attempt to commission the filter unaccompanied since this may lead to undesired damage and may affect your warranty coverage.

9. Operation and Control Safety Instructions

1. Do not operate the filter before reading carefully and being familiar with its operation instructions.
2. Observe the safety stickers on the filter and never perform any operation contradicting the instructions given.
3. Never operate or use the filter for purposes other than its original design and operational envelope.

10. Maintenance Safety Instructions

Before any maintenance or non-regular operation please read the following:

1. Servicing the filter should be done only by technicians authorized by Amiad.
2. Disconnect the filter from the power supply and lock the Main Power Switch.
3. Disconnect the compressed air supply, release the residual pressure, and lock the Pneumatics Main Valve.
4. Disconnect the filter from the water system by closing and securing the Manual Inlet Valve. In cases where the downstream piping network is pressurized, close and secure the Manual Outlet Valve.
5. Release the residual water pressure by opening the Pressure Release / Drainage Valve slowly and gradually.
6. Empty the filter by opening the Drainage Valve.
7. In hot water systems, wait until the filter components cool off to a safe temperature.
8. Place warning signs around the work area as required by the local standards and procedures.
9. Inspect the filter's safety stickers and replace any damaged or faded sticker.

Mechanical

1. When working on the filter use only appropriate standard tools.
2. Always open and close valves slowly and gradually.
3. Remove grease and fat material residues in order to avoid slipping.
4. Before disconnecting the filter from the water supply, electricity and pneumatics and before releasing the filter's residual pressure.
5. **DO NOT:**
 - loosen or unscrew bolts
 - remove any protection cover
 - open any service port flange

6. Avoid splashing and water leakage to minimize slippage, electrification, or damage to the equipment, caused by moisture.
7. While using lifting equipment, make sure that the filter or the lifted part is secured and in a safe manner.
8. Do not leave lifted equipment if there is no necessity. Avoid working below lifted equipment.
9. Wear a safety helmet, goggles, gloves, and any other personal safety equipment required by the local standards and regulations.
10. Human entry into a filter must be done in accordance with the relevant local safety instructions, standards, and regulations for working in hazardous environment.
11. Manual cleaning of filter media using high water pressure or steam should be performed in accordance with the cleaning system instructions, the local standards and regulations and without endangering the operator or the vicinity
12. Manual cleaning of filter element using acid or other chemical agents should be performed in accordance with the relevant material safety instructions, the local standards, and regulations and without endangering the operator or his vicinity.

Before returning to regular operation

1. Re-assemble any protection covers or protection mechanisms removed during service or maintenance operations.
2. Make sure that all the tools, ladders, lifting devices, etc. used during the maintenance procedures are taken away from the filter area and stored
3. In order to return the filter to regular operation, follow the First Start-up Operation instructions as detailed in your user manual.
4. For filters used in potable water systems it is required to disinfect the filter according to the local water authority standards and regulations before putting it back to service.

Dimensional Drawing

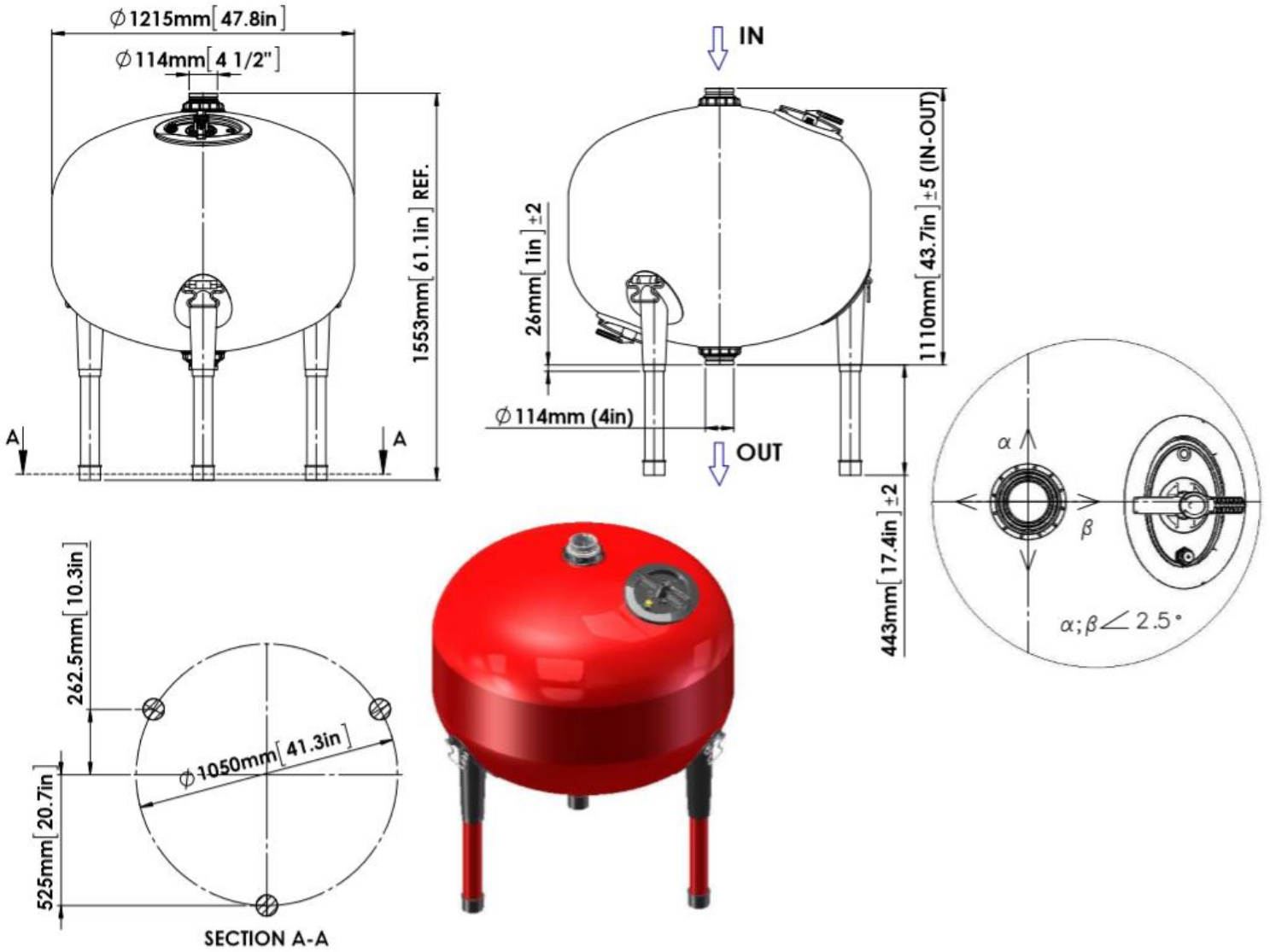

1. Media Filters

Pressure filtration vessels with loose media are widely used in industrial and irrigation filtration applications. Amiad’s AGF PRO Media filter-vessels are high quality, corrosion resisting tanks, designed for flexibility and custom designed applications. The Media vessels are designed for perfect water distribution during filtering and back Backwashing, providing high filtration efficiency. The AGF PRO filters line consists of the necessary accessories for constructing a fully operational filtration application: a complete line of manifolds, standard connectors, valves, granular media types and control systems.

There are various granular bed-types for perfect matching with the raw water type and the filtration degree required. In addition to other bed types, these may include various grades of sand, gravel, and basalt.

A typical depth filtration installation can be assembled from a single unit or several media vessels connected together to form a filtration battery. The number of the vessels, the diameter of the manifolds and the size and number of the valves depend on the required flow-rate, raw water quality, and the required filtration degree of the system.

2. How the AGF PRO Filters Operate

The AGF PRO are Pressurized Media filters which operate by trapping the suspended particles in unfiltered water as it flows through a bed of media in a pressurized tank.

The recommended filter media are: crushed basalt, crushed silica, quartz sand, AFM, and other catalytic media. The sizes of the media vary, causing the water to flow through a maze of passages on its way through the media bed, from the inlet to the outlet of the filter.

Due to the large volume and contact area between the water and the media particles, various physical forces are applied and act to retain the contaminating particles.

The efficiency of large particle retention is high, as long as the media is kept clean. The catalytic media type applies additional chemical-physical attraction forces between the media and particles, especially those of organic nature, giving more efficient organic material removal. In addition, the round shaped media particles cleaning requires less water in comparison with other media types.

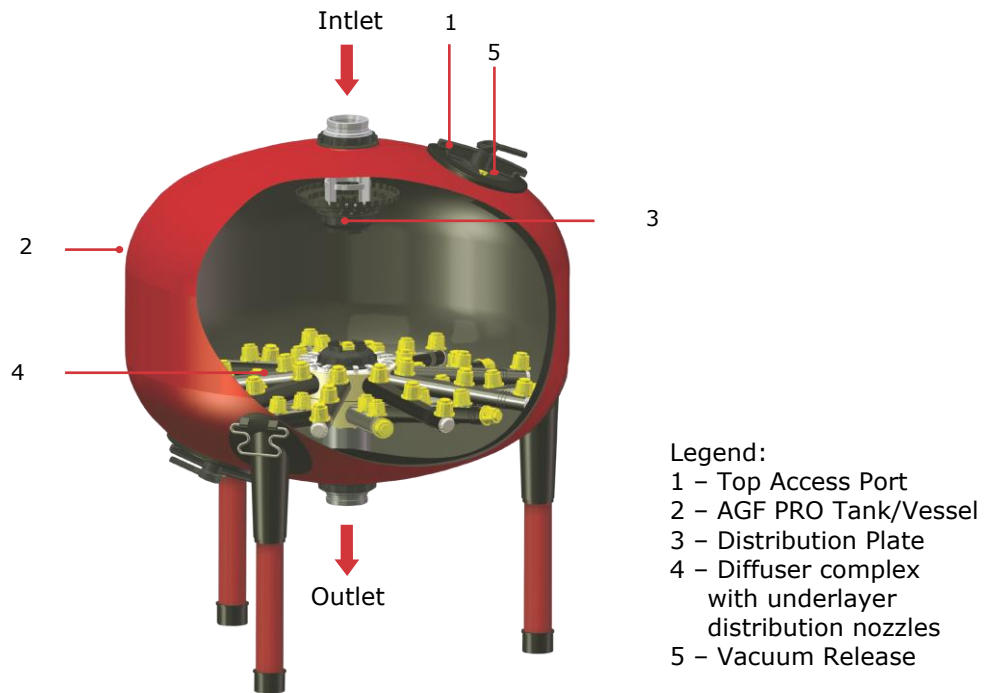

3. The Filtration Process

Filtering with media filters, also known as depth filtration, is done by filtering water through a thick layer of graded particles, called the filter bed. These particles can be sand, gravel or other granular materials. The filtration degree depends on the effective size of the bedding and the water velocity through the filter.

Raw water enters from the filter inlet and percolates through the filter bed. Suspended materials come into contact and attach to the media particles. Filtered water flows through the filtration nozzles and out through the filters outlet.

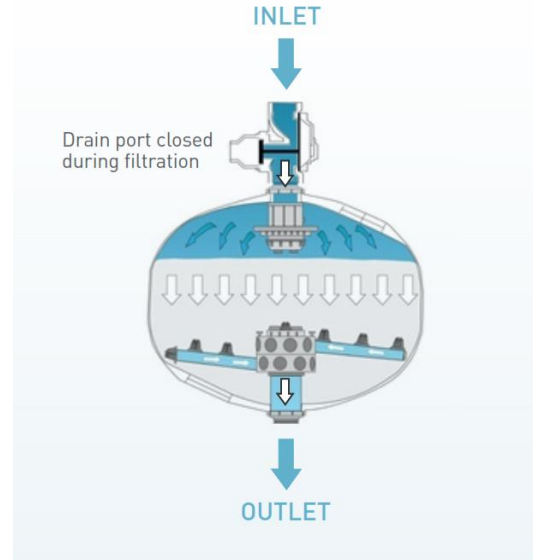

4. The Backwash Process

The cleaning is done by backwashing; pressurized water flows in reverse direction – from the nozzles upwards, causing suspension of the filter bed, thus releasing the suspended matter from the bedding. The dirt particles are then washed out of the filter through the back-backwash valve. In automatic media filters installations the cleaning process is done by the system’s controller. When the pressure differential switch senses that the differential pressure across the system reached a pre-set value, a signal is sent to the Backwashing controller and the self-cleaning process begins.

The restriction control flow valve on the drain manifold needs to be adjusted properly. This is essential so debris will be backwashed out of the filter while the media will remain in the filter tank.

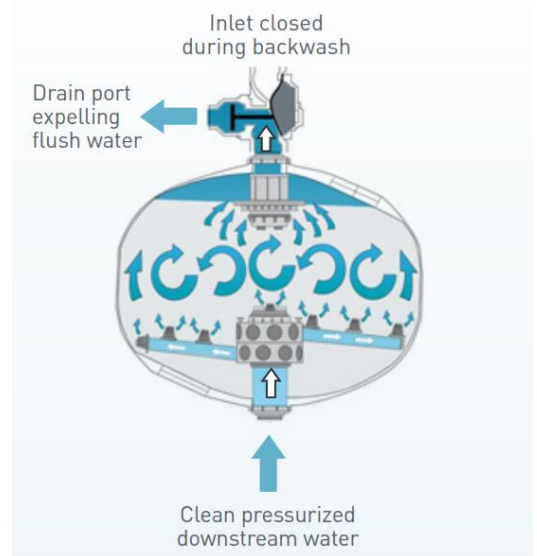

Installation

1. Pre Installation

1. Select a convenient location for the installation of the filter, where operation and maintenance will be optimal. It is recommended that a lifting device is available for maintenance.
2. Prepare a thick concrete base (minimum 4"/100mm) for the filter/battery. It is recommended that the site dimensions exceed the filter/ battery dimensions by at least 1 m (3.2 ft.) on all sides. To ensure that surface water collects and flows to a lower elevation, away from the installation site, make a 2% drainage slope to the desired direction.
3. Arrange suitable lighting at the area around the filter, to enable good visibility and safe maintenance.
4. Arrange suitable platforms and safety barriers to enable easy access to the filter. Do not climb on pipes and other equipment.
5. Flush the main water line thoroughly, before connecting it to the filter. This way any large debris that may damage the filter will be removed.
6. Locate the filter in its place with careful attention to the correct direction of flow.
7. Installation drawing:

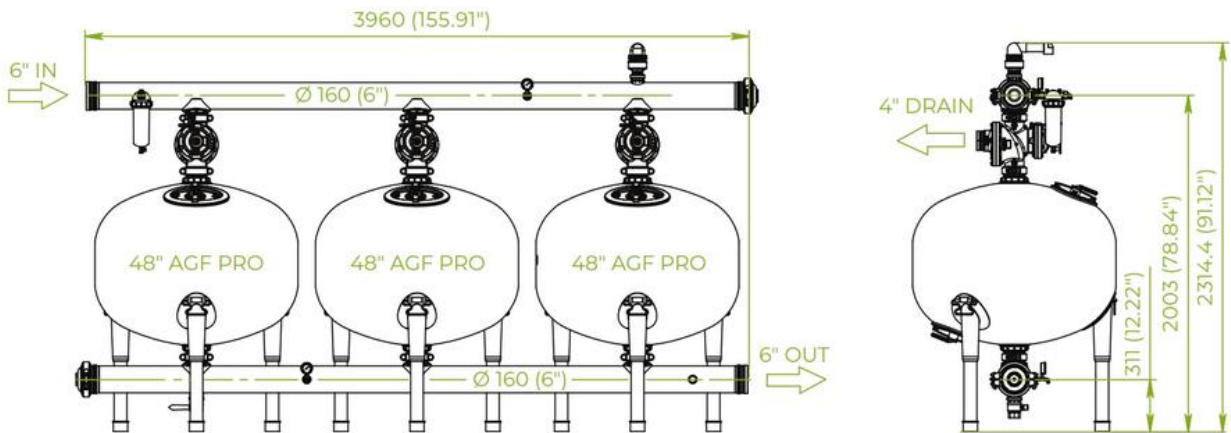

2. Filter Assembly

1. The filter is supplied disassembled.
2. Open the filter's packaging and remove the upper Styrofoam cover.
3. Before assembly examine the vessel's body. Open the filter's upper service port and make sure that no internal components are missing or displaced. Close the filter's service ports tightly.
4. Take out the three filter's legs out of the packaging and carefully connect each leg to its base.
5. Check that both the top and bottom covers are in place and tighten firmly, by hand only. Do not over tighten the bolts.

3. Leakage Test - Before filling the media

1. Close the filter's service ports.
2. Make sure that the outlet connection of the filtration system to the customer's water system is closed.
3. Slowly open the inlet port and let water flow into the filter. **Attention - maximal pressure allowed is 6 bar (87psi)!**
4. Check the valves' connections and manifolds for leaks and correct any leak found.
5. Close the water and empty the water from the filter vessel.

4. Filling-Up the Media

1. Use personal protective gear when handling the media. Follow the media safety data instructions as provided by the media's manufacturer.
2. Remove the top access cover of the AGF PRO filter vessel. Before adding any media to the filter, make a visual inspection inside the filter tank to make sure that there are no foreign objects inside.
3. Visually check the nozzle covers and connector pins to be sure that they are all in place and secured straight.
4. It is required to fill the filter tank with water before adding the media.
5. Fill the AGF PRO vessel with water until all the filter nozzles are covered.
6. Fill the media through the tank's top access port up to the level indicated on the label affixed to the filter tank exterior (35 cm above distribution nozzles).
If two media grades are used, start with the coarse media and fill it just above the nozzles line (1), pour the finer media to the level indicated on the label affixed to the filter tank exterior, 35 cm above distribution nozzles (2).
7. Remove remaining media particles from the threads and covers' sealing area.
8. Check that both the top and bottom covers are in place and tighten them firmly (but gently) by hand only.

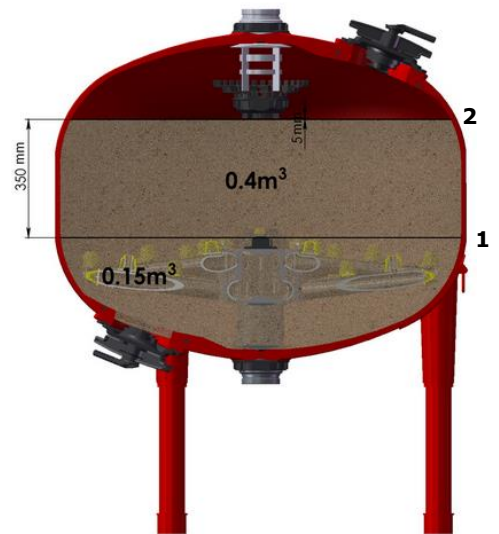

5. Initial Operation

1. Open the main raw water supply valve and let the pressurized water flow into the system.
2. Check the system's operation under pressure.
Minimum pressure for Backwashing is 2 bar (29 psi). It should be measured during backwash at the port located in the outlet manifold of the system.
3. Perform a manual backwash cycle and continue Backwashing the filter until the drain water is clean.
4. Make sure that the Backwashing control flow valve is set to 40-60 m³/h (155-180 USgpm) and no media is escaping to the drain.
5. Set the DP switch to 0.5 bar (7 psi) and set the required Backwashing time interval.

Maintenance

1. General inspection

In order to check the proper operation of the filter, initiate a self-cleaning cycle: Check that the backwash valves open and close properly and verify that by the end of the process clear water flow out of the drain.

2. Periodic inspection

1. Check for leaks from connections and fittings
If you found any leaks, fix them and re-secure the connections if required.
2. Start a backwash cycle manually and complete it.
3. When the filter is not in use for a long cessations period, the filter needs be drained after having been disinfected, and left in a dry condition until being used again.
4. In environments where freezing conditions occur, open all filter covers, drain the water totally out of the filtration system. When the filter is drained, close the upper covers.

3. Annual inspection

1. Once a year stop the system operation, drain the filters, close all the valves and release any pressure.
2. Open the filter's upper service port and visually inspect the media position.
If media level is below the initial line, re-check the flow control valve on the drain manifold to see that the media is not escaping. Otherwise make sure that the distribution nozzles are not damaged.
3. If needed, complete the missing amount of media up to the required level (page...)
4. Close the service port, restart the system and perform several backwash cycles before returning the system to regular operation.

4. Replacing the media

1. The sand media is replaced depending on a few parameters and media type. Consult your local dealer and/or manufacturer if a replacement is needed.
2. The media replacement process starts by closing all the valves and verifying that no pressure remains in the filter tank.
3. Open the top service cover.
4. Open the 3" plug on the lower cover, or start the pump (if installed), and drain all the water and sand from the filter. Remove the lower cover for faster draining. Do not use sharp tools to help remove the sand as distribution nozzles can be damaged.
5. Rinse and clean the inside of the filter tank.
6. Check the distribution nozzles.
7. Close the 3" plug and install the lower cover (make sure threads and sealing area are free of media particles).
8. Fill the tank with water until all the filter nozzles are covered and add the new media as described in section 4 page 14 (filling up the media).
9. Open all the valves for normal operation, and readjust the flow control valve on the drain manifold. See instructions on page 11 (Backwash Process) for further instructions.

Troubleshooting

SYMPTOM	POSSIBLE CAUSES	SOLUTIONS
Filter station differential pressure increases rapidly during operation, especially at start-up	Excessive flow rate	During system start-up, throttle downstream flow to the designed flow rate. Use a manual valve or pump control/sustaining valve.
	Unusual concentration of contaminants	Check water source quality. See an Authorized Amiad Dealer for assistance.
All the filters in station will not backwash	Controller output problem	Check that the controller is on and programmed correctly. Attempt to manually actuate the solenoid with the clock. The solenoids should emit a clicking noise when actuated. Clean the command filter.
	Insufficient downstream pressure for backwash	Use the manual knob on the base of the solenoid to backwash one tank. Note the downstream pressure reading. If the pressure falls below 20 psi, it may be necessary to throttle the field valves to build up sufficient backwash pressure.
	Hydraulic command system failure	Check to be sure the isolation valve is in the "on" position. Remove one of the hydraulic tubes leading to the solenoids and verify that pressurized water is available. Inspect the hydraulic command filter for contamination.
Filter station differential remains high after backwash	Gauge error	Check gauge differential on manifolds against the differential gauge in the controller. If there is a discrepancy, check readings with a new gauge.
	Insufficient backwash pressure	Verify that the downstream pressure during backwash is at least 20 psi. If it is not, it may be necessary to throttle a valve downstream of the filter station to sustain sufficient backwash pressure.
	Insufficient backwash flow	Check the backwash Restriction Valve setting. Adjust according to the procedures outlined in the backwash Restriction Valve Adjustments section.
	Excessive contamination of media	Open the access cover and inspect the media bed after a backwash. Verify that the sand level is correct and that there is not an excessive amount of debris in the sand. Verify that the backwash manifold line meets the size requirements outlined in the backwash Manifold Assembly section.

Leaking around grooved couplings	Pinched gasket	Remove couplings and inspect gasket. Apply gasket lube to prevent pinching.
	Torn or cracked gasket	Remove torn gasket and replace.
	Components out of alignment	Remove couplings and gaskets and inspect grooved fittings. Fittings should join squarely with no major gaps.
Leaking around access ports or top access vent	Debris between gasket and seat	Remove gasket and inspect gasket and seat for any debris.
	Torn or cracked gasket	Inspect gasket for cracking or other damage - replace if necessary.
	Cracked access cover	Inspect access cover for cracks or damage - replace if cracked or defective.
	Torn or cracked O-ring	Remove top access cover and inspect vent O-ring for damage - replace if necessary.
	Damaged vent	Inspect vent for possible cracks - replace if necessary.
One or several filters will not backwash	Controller output problem	Check for correct controller output with multi-tester or switch solenoid wires with another station to check for output signal.
	Solenoid wiring is defective	Use ohmmeter to verify that wiring is intact. Attempt to manually activate the solenoid with the knob on the base.
	On filters with manual selector valve - valve setting incorrect	Verify that selector valve knob is pointed towards the solenoid.
	Solenoids clogged or damaged	Open solenoids and inspect internal ports for evidence of clogging. Open carefully to avoid losing the internal spring-loaded plunger.

AGF PRO Filter Parts List

No.	CAT. No.	DESCRIPTION	Material	QTY.
1	710103-000376	Locking Nut	R.P.A.	2
2	770101-000023	Seal 9*123	EPDM	2
3	710101-000393	Inlet	R.P.P.	1
4	710103-000377	Distribution Plate	R.P.P.	1
5	710101-000391	Upper Sealing Nut	R.P.A.	1
6	700190-000159	AGF PRO Sealing Nut + nozzle + Holder	Various	1
7	710101-000833	Distribution nozzle	P.P.	54
8	710103-000016	Lower Sealing Nut	R.P.A.	1
9	710103-000018	Distribution nozzle Holder	R.P.A.	1
10	710101-000400	Pin	P.B.T.	18
11	760109-000110	Pin Washer Holder "Flic"	P.P.	1
12	700190-000156	Upper Diffuser Complete	Various	9
13	710101-000397	Upper Diffuser	P.P.	9
14	710103-010374	Plug AGF PRO	P.P.	9
15	710103-000378	Drum	R.P.P.	2
16	710101-000398	Lower Diffuser	P.P.	9
17	700190-000157	Lower Diffuser Complete	Various	9
18	710101-000394	Outlet	R.P.P.	1
19	720601-000044	Grp Body	GRP	1
20	760109-000108	Handle	S/ST	3
21	710103-000383	Lower Cover	R.P.A.	1
22	770101-000019	'O" Ring 76*4	EPDM	2
23	710101-000413	Lower Plug	R.P.A.	2
24	700190-000153	Lower Cover Complete	Various	1
25	770104-000020	Shaped Seal 45 Shore	EPDM	2
26	710103-000380	Bridge	R.P.A.	2
27	710101-000404	Tightening Screw	R.P.A.	2
28	See items 26 & 27			
29	710103-000382	Upper Cover	R.P.A.	1
30	770102-000042	'O" Ring 2*310	EPDM	1
31	760107-000007	Helical Spring	S/ST	1
32	710101-000408	Vacuum Release	P.P.	1
33	700190-000149	Upper Cover Complete	Various	1
34	760101-000173	Hex Bolt M10*30mm	S/ST304	3
35	760103-000028	Flat Washer M10	S/ST304	9
36	760101-000461	Hex Bolt M10*40mm	S/ST304	6
37	710103-000381	Leg Housing	R.P.A.	3
38	760109-000038	Leg Fiberglass	Various	3
39	710101-000410	Base Cup	R.P.A.	3
40	700190-000161	Legs Complete	Various	3
41	760109-000050	Locking Nut Wrench	G.M.	1
42	760109-000052	Lower Cover Wrench	G.M.	1

Parts Drawing

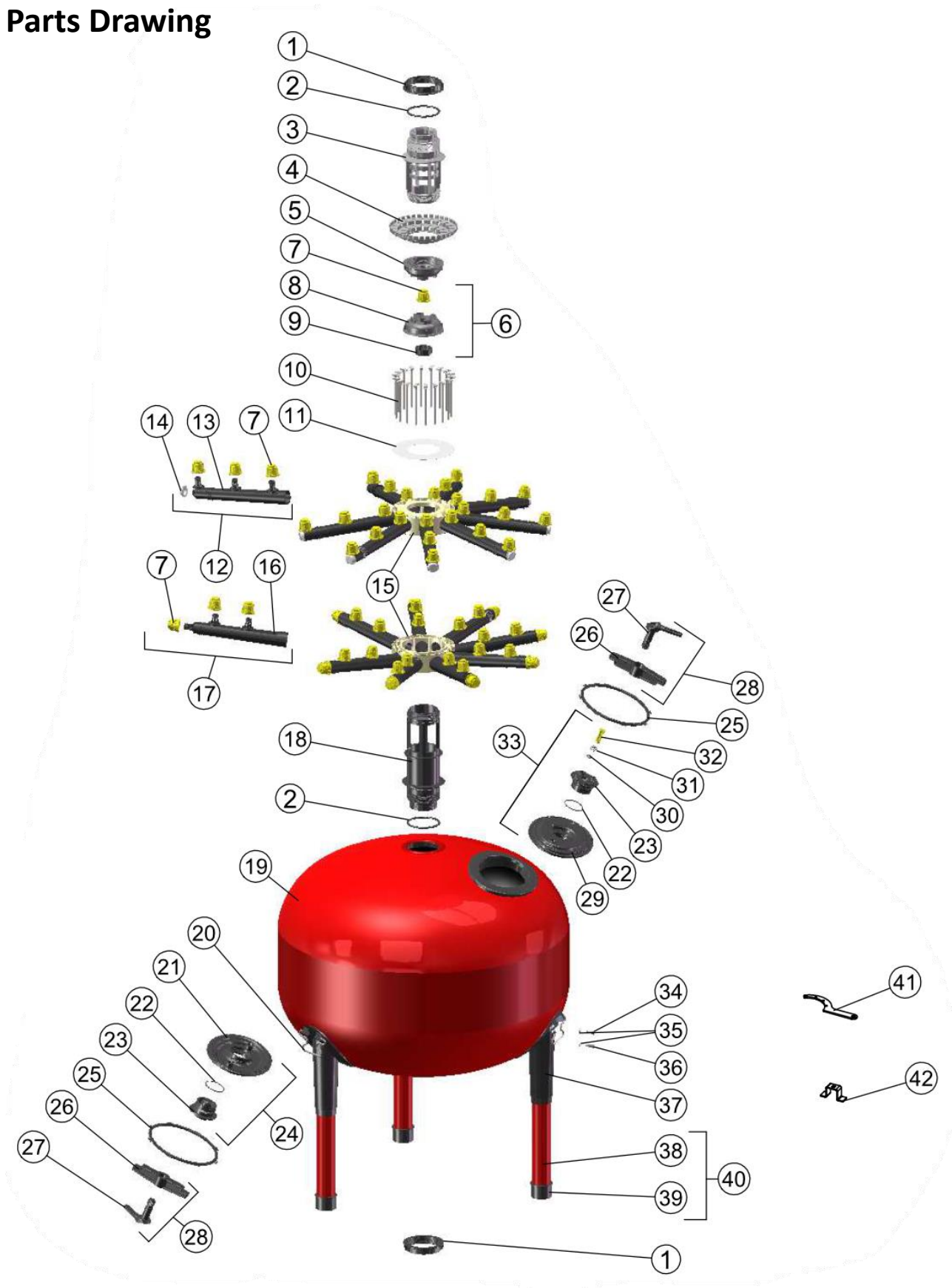

AMIAD LIMITED WARRANTY

1. This certificate applies to Amiad Water Systems Ltd. ("**Amiad**") products purchased by you (the "**Buyer**") from Amiad unless specifically agreed otherwise in writing by Amiad. This Warranty extends only to the original purchaser, and is not transferable to anyone who subsequently purchases, leases, or otherwise obtains the product from the original purchaser.
2. Amiad hereby warrants that the products are and will be free from defects in material and workmanship under normal use and service. Amiad warrants that it will correct manufacturing defects in the products, in accordance with the conditions set out in this Warranty.
3. This Warranty is enforceable for a period of 12 months after the date upon which the products were delivered (the "**Warranty Period**").
4. In the event that during the Warranty Period the Buyer discovers a defect in material and/or workmanship in any product or part (the "**Defective Product**"), it shall submit a written complaint to Amiad using Amiad's standard Buyer Complaint Form. For the receipt of the Buyer Complaint Form, the submission of the complaint or any questions please contact your service representative.
5. Upon written demand by Amiad the Buyer shall return the Defective Product - or a sample thereof - to Amiad, at Amiad's cost. If the Buyer ships any such Defective Product, Amiad suggests the Buyer package it securely and insure it for value, as Amiad assumes no liability for any loss or damage occurring during shipment. Provided however that in the event Amiad determines that this Warranty does not apply to such product, Buyer shall promptly reimburse Amiad for such cost (including freight and customs). Any returned product or part must be accompanied by the Warranty certificate and the purchase invoice. It is clarified that the Buyer may not return the Defective Product unless such return was coordinated and approved by Amiad in advance.
6. Amiad's obligation under this Warranty shall be limited to, at Amiad's option, the repair or exchange, free of charge, of the product or any part which may prove defective under normal use and service during the Warranty Period. The provision of a repair or replacement of a product during the Warranty Period will result in an extension of the Warranty Period by an additional period of 12 months, provided that the total accumulated Warranty Period shall in any event be no more than 18 months from the date upon which the products were delivered.
7. This Warranty is valid on the condition that the products are installed according to Amiad's instructions as expressed in Amiad's instruction manuals and according to the technical limitations as stipulated in Amiad's literature or as stated by a representative of Amiad.
8. This Warranty will not apply to damaged or defective products resulting from or related to:
 - (i) Fire, flood, power surges or failures or any other catastrophe and/or unforeseen occurrence, such as but not limited to those for which the Buyer is customarily insured for, or any force majeure events;
 - (ii) Fault, abuse or negligence of the Buyer;
 - (iii) Intake water not meeting the agreed standards, as set forth in a written document, approved by Amiad, or improper storage;
 - (iv) Improper or unauthorized use of the product or related parts by the Buyer, including Buyer's failure to operate the product in conformity with the recommendations and instructions of Amiad, as set forth in Amiad's manuals and other written materials, the operation of the product other than by a trained and qualified operator, or improper installation of the product by a third party not authorized by Amiad;
 - (v) Performance by the Buyer of maintenance or operation other than in conformity with the recommendations and instructions of Amiad, or other than in accordance with procedures defined in the literature supplied for products (including the timely replacement of requisite parts), and for services provided other than by a trained and qualified advanced operator; or
 - (vi) Any alteration, modification, foreign attachment to or repair of the products, other than by Amiad or its authorized technical representatives.
9. In no event shall Amiad be liable to the Buyer or any third party for any damages to property, or for any intangible or economic loss, including loss of profits, loss of customers or damage to reputation, for any damages, including indirect, special, consequential damages, or punitive damage arising out of or in connection with this Warranty, or arising out of or in connection with the product's performance or failure to perform, even if it has been advised of the possibility of such damages.
10. Amiad will be excused for failure to perform or for delay in performance hereunder if such failure or delay is due to causes beyond its reasonable control or force majeure preventing or hindering performance.
11. This Warranty set forth herein is the only contractual warranty given by Amiad and is provided in lieu of any other warranties created by any documentation, packaging or otherwise.
12. Amiad makes no warranty whatsoever in respect to accessories or parts not supplied by Amiad. In the event that Amiad is required to correct a Defective Product or product not covered by this Warranty, it will do so solely in consideration for additional fees.
13. The parties will actively endeavor to amicably settle any dispute arising between them. In the event that the parties are unable to reach an equitable settlement of such dispute, any claim or lawsuit related to the Warranty, its validity execution, its performance be brought before only the courts of Tel-Aviv, Israel. Israeli law will govern the Warranty, to the exclusion of any conflict of law rules.



Headquarters: 54/18 Bui Quang La, Ward 12, Go Vap District, HCMC, Viet Nam
Office: 12 DHT10B, Dong Hung Thuan Ward, District 12, HCMC, Viet Nam
Phone: (028) 6258 5368 - (028) 6291 9568
Email: info@atswatertechnology.com
Website: www.atswatertechnology.com

The product is compliant with European Directive 2014/68/EU PED – SEP category.

SEP products do not bear the CE marking, in conformity with the art.4 par.3 Pressure Equipment Directive 2014/68/EU

Manufacturer:

Amiad Water Systems Ltd.

D.N. Galil Elyon 1, 1233500, Israel Tel: 972 4 690 9500 | Fax: 972 4 814 1159 Email: info@amiad.com

EC Representative for CE Matters:

Obelis S.A, Boulevard Général Wahis 53, B-1030 Brussels, BELGIUM. Email: info@obelis.com

EC Declaration https://www.amiad.com/certificatesDownload_CE.asp