

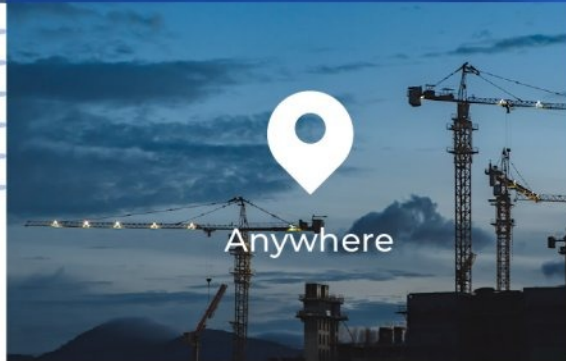

**AGFPRO**

Advanced corrosion-proof  
all polymeric media filter

# MAST FILTRA



**Your water  
challenge.  
Our filtration  
solution.**

Amiad Water Systems is a world leader in water treatment and filtration solutions. For over 57 years Amiad has devoted its passion and commitment to developing a comprehensive line of water filtration systems for a wide range of industrial applications.

Our solutions are integrated into the core of water filtration systems in the following industries and applications: metal, plastic, energy, chemical, water treatment and salt water disposal.

# MASTERS OF FILTRATION



Any Technology



Any Water Source



We develop filters that are able to cope with any water quality, in any geographical location.

We've spent years mastering filtration technology so we can offer a wide range of filters for every industrial need, including screen, disc, microfiber or media technology.



Disc  
Technology



Screen  
Technology



Media  
Technology



Microfiber  
Technology

We consider every challenge as an opportunity to work side by side with our customers to solve their problems.

We'll go anywhere to ensure our filters perform as expected, 24/7, every day of the year.

When you want a high-performance solution for your water filtration system, consult with Amiad. We focus on doing what we do best.

**Amiad. Masters of Filtration.**

# AGFPRO: Strong and Reliable.

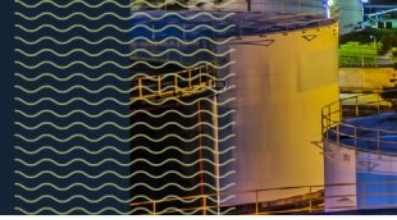

## AGFPRO FEATURES

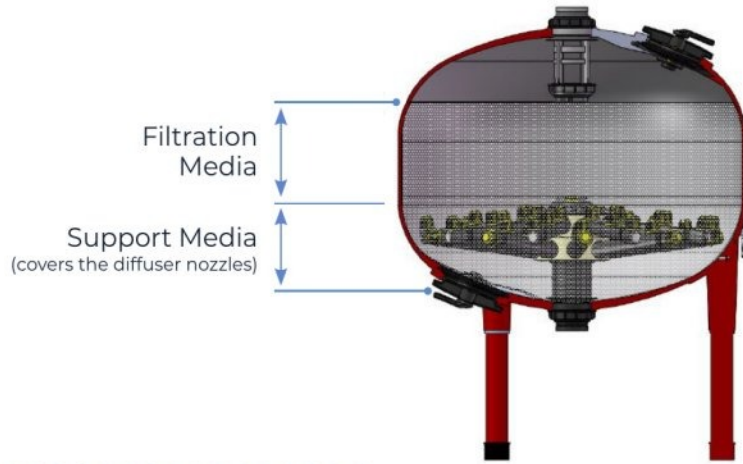

Superior underdrain system designed with 55 diffuser nozzles



Light weight for easy installation, no crane required



Two large elliptical access ports for easy inspection and media loading



Constructed with special synthetic materials

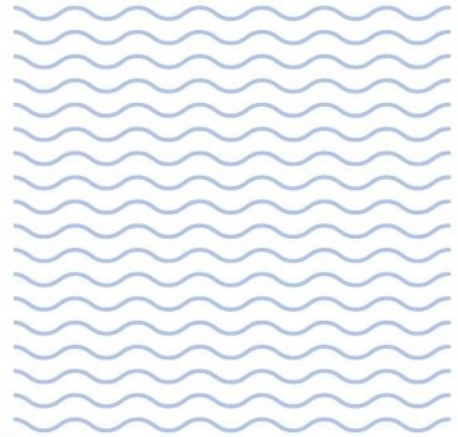

Effective and economic backwash



Corrosion-proof and high chemical resistance



## AGF PRO Filter 48" Head Loss

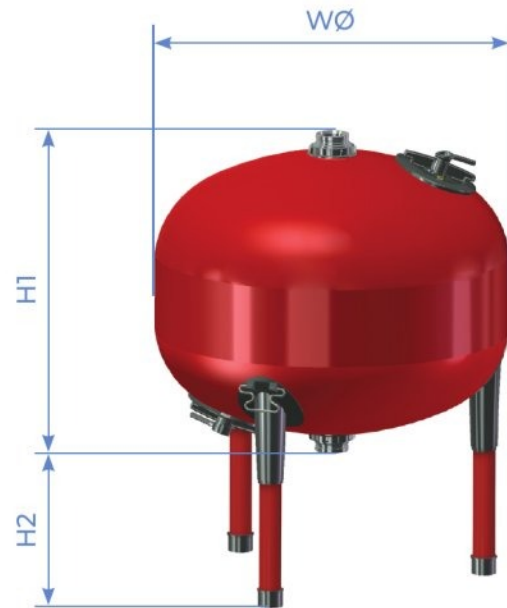
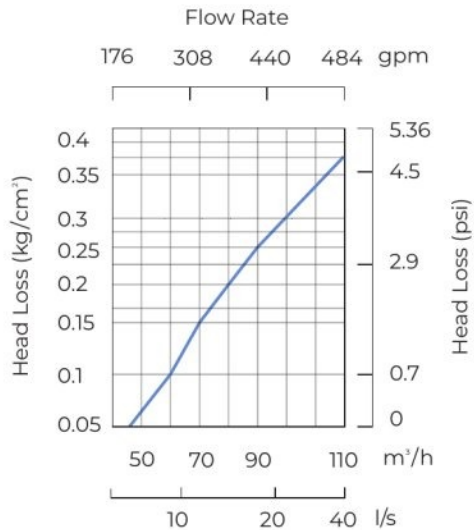

## Technical Data

Maximum pressure	6 bar (85 psi)
Minimum pressure during filtration mode	1.4 bar (20 psi)
Minimum pressure on the downstream side during backwash mode	2 bar (29 psi)
Maximum filtration flow* (single filter)	80 m³/h (352 gpm)
Diameter inlet/outlet (single filter)	102 mm (4" grooved)
Filter tank diameter - WØ	1,220 mm (48")
Distance between end connections - H1	1,110 mm (44")
Outlet height - H2	443 mm (17")
Weight [empty]	132 kg (290 lb)
Approx. media weight	732 kg (1610 lb)

\*Depending on type of media used

## Filtration Media Data

Media type	Mean effective media size	Filtration Rates**	Min. flow for backwash
Quarz 0*	0.5-0.8 mm (0.019"-0.031")	8-17m³/h (35-75 gpm)	42 m³/h (185 gpm)
Quarz 1*	0.8-1.2 mm (0.031"-0.047")	10-25 m³/h (44-110 gpm)	42 m³/h (185 gpm)
PEP active 0*	0.25-0.5 mm (0.0098"-0.019")	-	40 m³/h (176 gpm)
PEP active 1*	0.4-1.0 mm (0.015"-0.039")	10-20 m³/h (44-88 gpm)	40 m³/h (176 gpm)
Quarz 2	1.2-2.0 mm (0.047"-0.078")	50-80 m³/h (220-352 gpm)	46 m³/h (202 gpm)
Basalt 1	1.0-2.5 mm (0.039"-0.098")	50-80 m³/h (220-352 gpm)	54 m³/h (238 gpm)
Basalt 2	1.7-3.5 mm (0.067"-0.138")	-	54 m³/h (238 gpm)
Crushed silica 12	1.1-1.2 mm (0.043"-0.047")	50-80 m³/h (220-352 gpm)	54 m³/h (238 gpm)
Crushed silica 16*	0.6-0.7 mm (0.023"-0.275")	8-17 m³/h (35-75 gpm)	46 m³/h (202 gpm)
Crushed silica 20*	0.45-0.5 mm (0.017"-0.019")	-	42 m³/h (185 gpm)

\*Requires Quartz 2 as a support layer

\*\* Consult Amiad for optimum flow depending on filtration degree and water quality.

# Dimensions and technical specifications

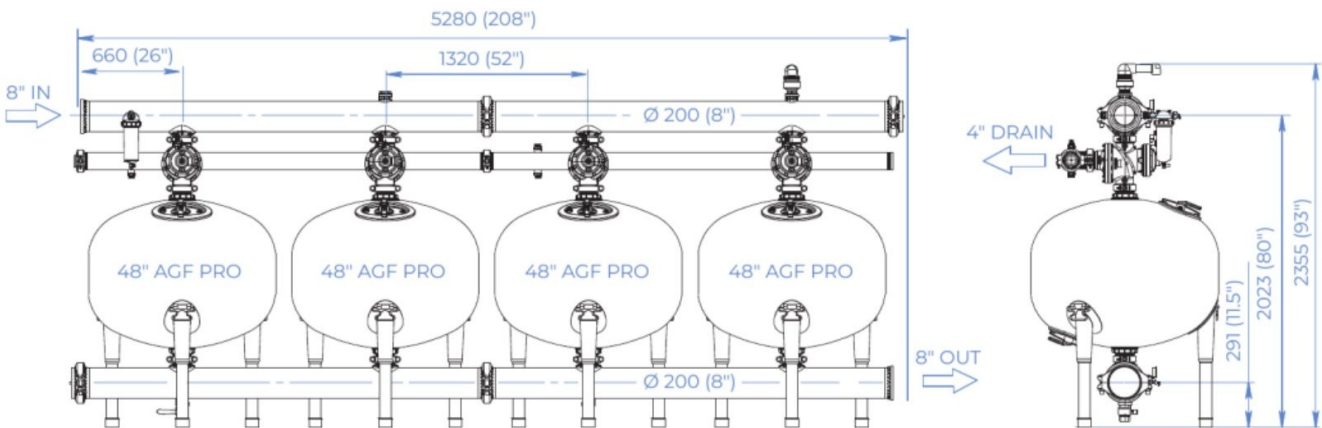
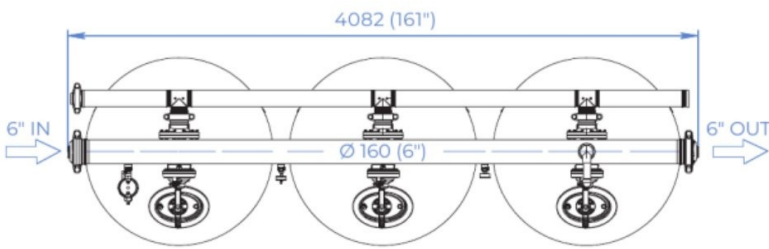
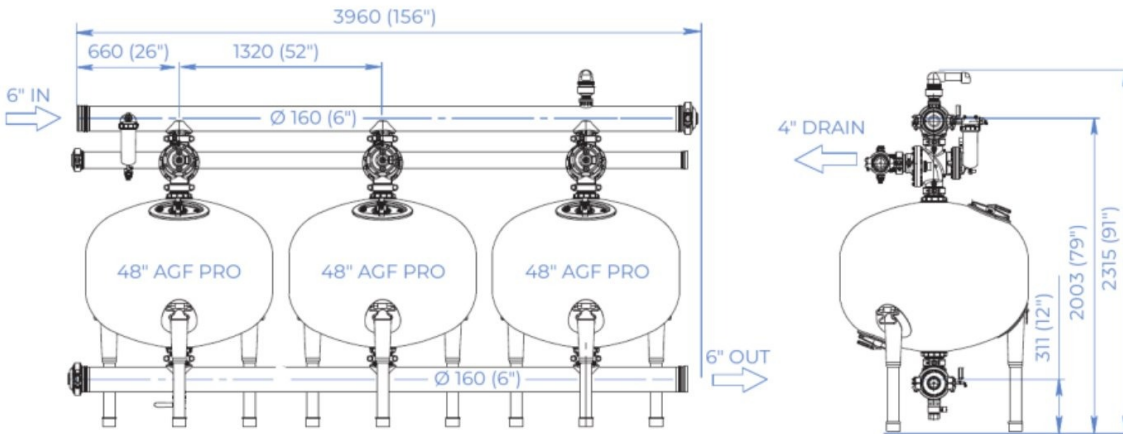
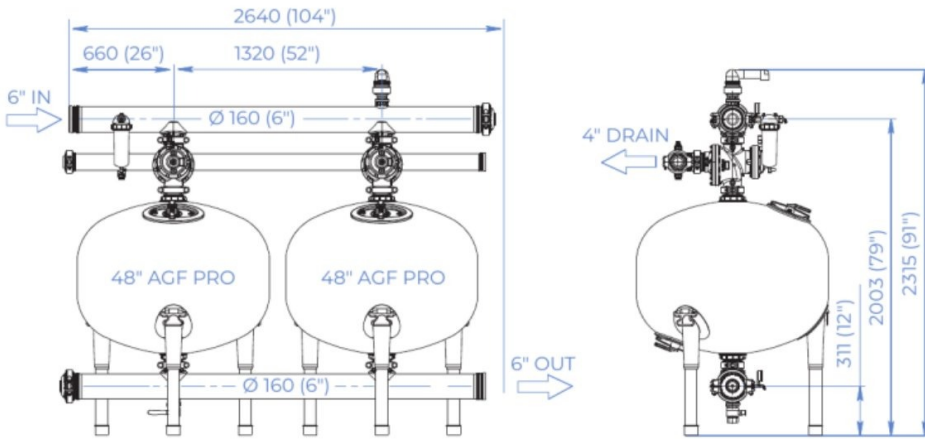

mm (inch)



## AGF PRO Battery

No. of filters	2	3	4	5	6
Distance between filter connections	1,320 mm (52")				
Distance between inlet manifold and filter #1	660 mm (26")				
Backwash pipe diameter	110 mm (4")				
Backwash valve outlet	4" grooved x 4" grooved				
Backwash center height	1,660 mm (65")				
Inlet center height	2,003 mm (78.84")		2,023 mm (79.62")		Depends on configuration
Outlet manifold center height	310 mm (12.22")		291 mm (11.44")		Depends on configuration
Length	2,639 mm (103.9")	3,960 mm (155.9")	5,280 mm (207.8")	Depends on configuration	

## Flow Rates and Media Requirements

No. of Filter Tanks	Maximum Flow			Media Requirements	
	Clean Water	Average Water	Dirty Water	Support media	Filtration Media
1 (inline)	65-80 m <sup>3</sup> /h (286-352 gpm)	50-65 m <sup>3</sup> /h (220-286 gpm)	40-50 m <sup>3</sup> /h (176-220 gpm)	0.15 m <sup>3</sup> (5 ft <sup>3</sup> )	0.4 m <sup>3</sup> (14 ft <sup>3</sup> )
2 (inline)	130-160 m <sup>3</sup> /h (572-700 gpm)	100-130 m <sup>3</sup> /h (440-572 gpm)	80-100 m <sup>3</sup> /h (352-440 gpm)	0.30 m <sup>3</sup> (11 ft <sup>3</sup> )	0.8 m <sup>3</sup> (28 ft <sup>3</sup> )
3 (inline)	195-240 m <sup>3</sup> /h (859-1,057 gpm)	150-195 m <sup>3</sup> /h (660-859 gpm)	120-150 m <sup>3</sup> /h (528-660 gpm)	0.45 m <sup>3</sup> (16 ft <sup>3</sup> )	1.2 m <sup>3</sup> (42 ft <sup>3</sup> )
4 (inline)	260-320 m <sup>3</sup> /h (1,145-1,409 gpm)	200-260 m <sup>3</sup> /h (880-1,145 gpm)	160-200 m <sup>3</sup> /h (704-880 gpm)	0.60 m <sup>3</sup> (21 ft <sup>3</sup> )	1.6 m <sup>3</sup> (46 ft <sup>3</sup> )
5	325-400 m <sup>3</sup> /hr (1,431-1,761 gpm)	250-325 m <sup>3</sup> /h (1,101-1,431 gpm)	200-250 m <sup>3</sup> /h (880-1,101 gpm)	0.75 m <sup>3</sup> (26 ft <sup>3</sup> )	2.0 m <sup>3</sup> (71 ft <sup>3</sup> )
6	390-480 m <sup>3</sup> /h (1,717-2,113 gpm)	300-390 m <sup>3</sup> /h (1,321-1,717 gpm)	240-300 m <sup>3</sup> /h (1,057-1,321 gpm)	0.90 m <sup>3</sup> (31.8 ft <sup>3</sup> )	2.4 m <sup>3</sup> (85 ft <sup>3</sup> )
7	455-560 m <sup>3</sup> /h (2,003-2,466 gpm)	350-455 m <sup>3</sup> /h (1,541-2,003 gpm)	280-350 m <sup>3</sup> /h (1,233-1,541 gpm)	1.05 m <sup>3</sup> (37 ft <sup>3</sup> )	2.8 m <sup>3</sup> (99 ft <sup>3</sup> )
8	520-640 m <sup>3</sup> /h (2,289-2,818 gpm)	400-520 m <sup>3</sup> /h (1,761-2,289 gpm)	320-400 m <sup>3</sup> /h (1,409-1,761 gpm)	1.20 m <sup>3</sup> (42 ft <sup>3</sup> )	3.2 m <sup>3</sup> (113 ft <sup>3</sup> )
9	585-720 m <sup>3</sup> /h (2,576-3,170 gpm)	450-585 m <sup>3</sup> /h (1,981-2,576 gpm)	360-450 m <sup>3</sup> /h (1,585-1,981 gpm)	1.35 m <sup>3</sup> (47.7 ft <sup>3</sup> )	3.6 m <sup>3</sup> (127 ft <sup>3</sup> )
10	650-800 m <sup>3</sup> /h (2,862-3,522 gpm)	500-650 m <sup>3</sup> /h (2,201-2,862 gpm)	400-500 m <sup>3</sup> /h (1,761-2,201 gpm)	1.50 m <sup>3</sup> (53.0 ft <sup>3</sup> )	4.0 m <sup>3</sup> (141 ft <sup>3</sup> )
12	780-960 m <sup>3</sup> /h (3,434-4,227 gpm)	600-780 m <sup>3</sup> /h (2,642-3,434 gpm)	440-550 m <sup>3</sup> /h (1,937-2,422 gpm)	1.65 m <sup>3</sup> (58 ft <sup>3</sup> )	4.4 m <sup>3</sup> (155 ft <sup>3</sup> )



## Headquarters

**Amiad Water Systems Ltd.**

Web: [www.amiad.com](http://www.amiad.com)

E-mail: [info@amiad.com](mailto:info@amiad.com)



**ATS WATER  
TECHNOLOGY**

**Headquarters:** 54/18 Bui Quang La, Ward 12, Go Vap District, HCMC, Viet Nam

**Office:** 12 DHT10B, Dong Hung Thuan Ward, District 12, HCMC, Viet Nam

**Phone:** (028) 6258 5368 - (028) 6291 9568

**Email:** [info@atswatertechnology.com](mailto:info@atswatertechnology.com)

**Website:** [www.atswatertechnology.com](http://www.atswatertechnology.com)

## The Americas

### USA

**Amiad USA Inc.**

Web: [us.amiad.com](http://us.amiad.com) | E-mail: [infousa@amiad.com](mailto:infousa@amiad.com)

### Mexico

**Amiad México SA DE CV,**

Web: [es.amiad.com](http://es.amiad.com) | E-mail: [infomexico@amiad.com](mailto:infomexico@amiad.com)

## Asia

### India

**Amiad Filtration India Pvt Limited**

Web: [amiad.com](http://amiad.com) | E-mail: [info-india@amiad.com](mailto:info-india@amiad.com)

### China

**Amiad China (Yixing Taixing Environtec Co., Ltd.)**

Web: [amiad.com.cn](http://amiad.com.cn) | E-mail: [infochina@amiad.com](mailto:infochina@amiad.com)

### South-East Asia

**Filtration & Control Systems Pte. Ltd.**

Web: [amiad.com](http://amiad.com) | E-mail: [info-singapore@amiad.com](mailto:info-singapore@amiad.com)

## Australia

**Amiad Australia Pty Ltd.**

Web: [au.amiad.com](http://au.amiad.com) | E-mail: [sales@amiad.com](mailto:sales@amiad.com)

## Europe

**Amiad Water Systems Europe SAS**

Web: [amiad.com](http://amiad.com) | E-mail: [industry-europe@amiad.com](mailto:industry-europe@amiad.com)

### German branch office

Web: [de.amiad.com](http://de.amiad.com) | E-mail: [industry-de@amiad.com](mailto:industry-de@amiad.com)

### United Kingdom

**Amiad Water Systems UK Limited**

Web: [amiad.com](http://amiad.com) | E-mail: [info-uk@amiad.com](mailto:info-uk@amiad.com)



 **amiad** INDUSTRY

# MASTERS OF FILTRATION

[www.amiad.com](http://www.amiad.com)

910101-001266/11.2021

Copyright © 2019 Amiad Water Systems Ltd. All rights reserved. The contents of this catalogue including without limitation all information and materials, images, illustrations, designs, icons, photographs, graphical presentations, designs, literary works, data, drawings, slogans, phrases, names, trademarks, titles and any other such materials that appear in this catalogue (collectively, the "Contents") are the sole property of Amiad Water Systems Ltd. ("Amiad"). Amiad has sole and exclusive right, title and interest in the Contents, including any intellectual property rights, whether registered or not, and all know-how contained or embodied therein. You may not reproduce, publish, transmit, distribute, display, modify, create derivative works from, sell or participate in any sale of, or exploit in any way, in whole or in part, any of the Contents or the catalogue. Any use of the catalogue or the Contents, other than for personal use, requires the advanced written permission of Amiad.