

Amiad Water Systems Ltd.

TAF-500 FILTERS

Serial number:	_____
Order number:	_____
Catalog number:	_____
Filtration degree:	_____
Tested by:	_____

Installation, Operation and Maintenance Instructions

910101-000115/06.2018



AMIAD Water Systems Ltd.

TAF-500 FILTERS

Installation, Operation and Maintenance Instructions



Disclaimer:

Copyright © 2018 Amiad Water Systems Ltd. All rights reserved.

The contents of this document, including without limitation all information and materials, images, illustrations, data, drawings, names and any other such materials that appear in this document are the sole property of Amiad Water Systems Ltd., including any intellectual property rights, whether registered or not, and all know-how contained or embodied therein. Amiad may alter, remove or change the Content without any further notice. You may not reproduce, copy, modify, create derivative works from, sell or participate in any sale of, or exploit in any way, in whole or in part, any of this document or its content.

The confidential nature of and/or privilege in the file enclosed is not waived or lost as a result of a mistake or error in this file. If you received this file in error, please notify Amiad immediately at info@amiad.com.

This document does not replace any certified drawing, procedure or information provided by Amiad in reference to a specific customer, site or project.

Amiad assumes that all users understand risks involved within this file and/or its attached materials. This document is given in good faith and is not intended to impose any obligation to Amiad. While every effort has been made to ensure the information in this manual is accurate and complete, we would appreciate if you can bring any errors or omissions to the knowledge of Amiad or consult Amiad experts or its authorized representatives if you have any questions.

Amiad Water Systems Ltd. D.N. Galil Elyon 1, 1233500, Israel Tel: 972 4 690 9500 | Fax: 972 4 814 1159 Email: info@amiad.com

TABLE OF CONTENTS

TABLE OF CONTENTS.....	3
TECHNICAL SPECIFICATIONS.....	4
GENERAL	4
FLUSHING DATA	4
CONTROL AND ELECTRICITY.....	4
CONSTRUCTION MATERIALS.....	4
STANDARD FILTRATION DEGREES.....	4
SAFETY INSTRUCTIONS	5
GENERAL	5
INSTALLATION.....	5
OPERATION, CONTROL AND MAINTENANCE	5
USE OF LIFTING EQUIPMENT.....	5
DIMENSIONAL DRAWING.....	6
DESCRIPTION OF FILTER OPERATION	7
DESCRIPTION OF FILTER OPERATION	7
FILTERING PROCESS.....	7
SELF-CLEANING PROCESS.....	7
INSTALLATION	8
DESIGN RECOMMENDATIONS.....	8
INSTALLATION INSTRUCTIONS.....	8
START- UP AND FIRST OPERATION.....	9
MAINTENANCE	10
CHECKING THE FILTER	10
CHECKING THE PD SWITCH CONNECTORS	10
WINTERIZATION	10
LEAKS.....	10
PARTS SCHEDULE 2" TAF-500 FILTER SECTION 1.....	11
PARTS DRAWING TAF-500 FILTER SECTION 1	12
PARTS SCHEDULE & DRAWING 2" TAF-500 FILTER SECTION 2	13
CONTROL DRAWING	14
AMIAD LIMITED WARRANTY.....	15

With any inquiry please quote Filter Serial Number, located on the filter housing.

TECHNICAL SPECIFICATIONS

General

Maximum flow rate	25 m ³ /hr; 110USgpm	Consult manufacturer for optimum flow depending on filtration degree & water quality.
Min. working pressure	1.5 bar; 22psi	Or lower if pressure is increased for flushing.
Max. working pressure	8 bar; 120 psi	
Filter area	465 cm ² ; 72 in ²	
Inlet/Outlet diameter	50 mm; 2"	Threads: BSP or NPT
Max. working temperature	60°C; 140°F	
Weight	11.6 kg; 25.6lb	

Flushing data

Exhaust valve	40 mm; 1 1/2"	
Flushing cycle time	16 seconds	
Wasted water per cycle	18 liter; 4.7 USgallon	
Minimum flow for flushing	4 m ³ /h; 18 USgpm	at 1.5 bar; 22 psi
Flushing criteria	Differential pressure of 0.5 bar (7psi), time intervals and manual operation	

Control and electricity

Rated operation voltage	220 V - Single phase	110 upon request
Electric motor	15 Watt	50 / 60 Hz, Gear output 48 / 58 R.P.M.
Current consumption	0.18 A	
Control voltage	24 VAC	

Construction materials

Filter housing and lid	NYLON
Screens	St.St. 316 Weave Wire screen with Polypropylene construction
Cleaning mechanism	PP, Delrin
Exhaust valve	Plastic, Natural rubber
Seals	NBR
Control	Brass, Stainless steel, PE, PP

Standard filtration degrees

	Stainless steel screen								
micron	500	300	200	130	100	80	50	25	10
mm	0.5	0.3	0.2	0.13	0.1	0.08	0.05	0.02	0.01
mesh	30	50	75	120	155	200	300	450	600

SAFETY INSTRUCTIONS

General

1. Prior to installation or any treatment given to the filter, read carefully the installation and operation instructions.
2. While maintaining the filter all standard safety instructions should be observed in order to avoid danger to the workers, the public or to property in the vicinity.
3. Please note, the filters enter into a flushing mode automatically, without prior warning.
4. No changes or modification to the equipment are permitted without a written notification given by the manufacturer or by its representative, on the manufacturer behalf.

Installation

1. Install the filter according to the installation instructions detailed in this manual.
2. Make sure to leave enough clearance so as to enable easy access for future treatments and safe maintenance operations.
3. Electric wiring should be performed by an authorized electrician only; using standardized and approved components.
4. Install main power disconnect cut-off switch close to the control panel.
5. If the control panel is installed in a location where there is no eye contact with the filter, a power disconnect cut-off switch should be installed near each filter unit.
6. Install the filter so as to avoid water splashing directly on the electrical components or on the control panel.
7. Additional safety devices should be installed on hot water applications to avoid skin burn danger.

Operation, Control and Maintenance

1. Disconnect the filter from power supply before maintenance or treatment.
2. Loosening or unscrewing bolts should be done only after the pressure in the filter had been released.
3. Avoid splashing and water leaking so as to minimize slipping, electrocution or damage to the equipment caused by moisture.
4. Always open and close valves slowly and gradually.
5. Remove grease and fat material residues in order to avoid slipping.
6. After treatment has been completed, re-assemble the protection covers of the drive mechanism.
7. Manual cleaning of filter element using high water pressure or steam, should be performed in accordance with the cleaning system instructions and without endangering the operator or his vicinity.
8. Manual cleaning of filter element using acid or other chemical agents should be performed in accordance with the relevant material safety instructions and without endangering the operator or his vicinity.

Use of Lifting Equipment

1. While using lifting equipment, make sure that the filter or the lifted part is chained securely and in a safe manner.
2. Do not leave lifted equipment hanging if not necessary. Avoid working below lifted equipment.
3. Wear a safety helmet while using lifting equipment.

DIMENSIONAL DRAWING

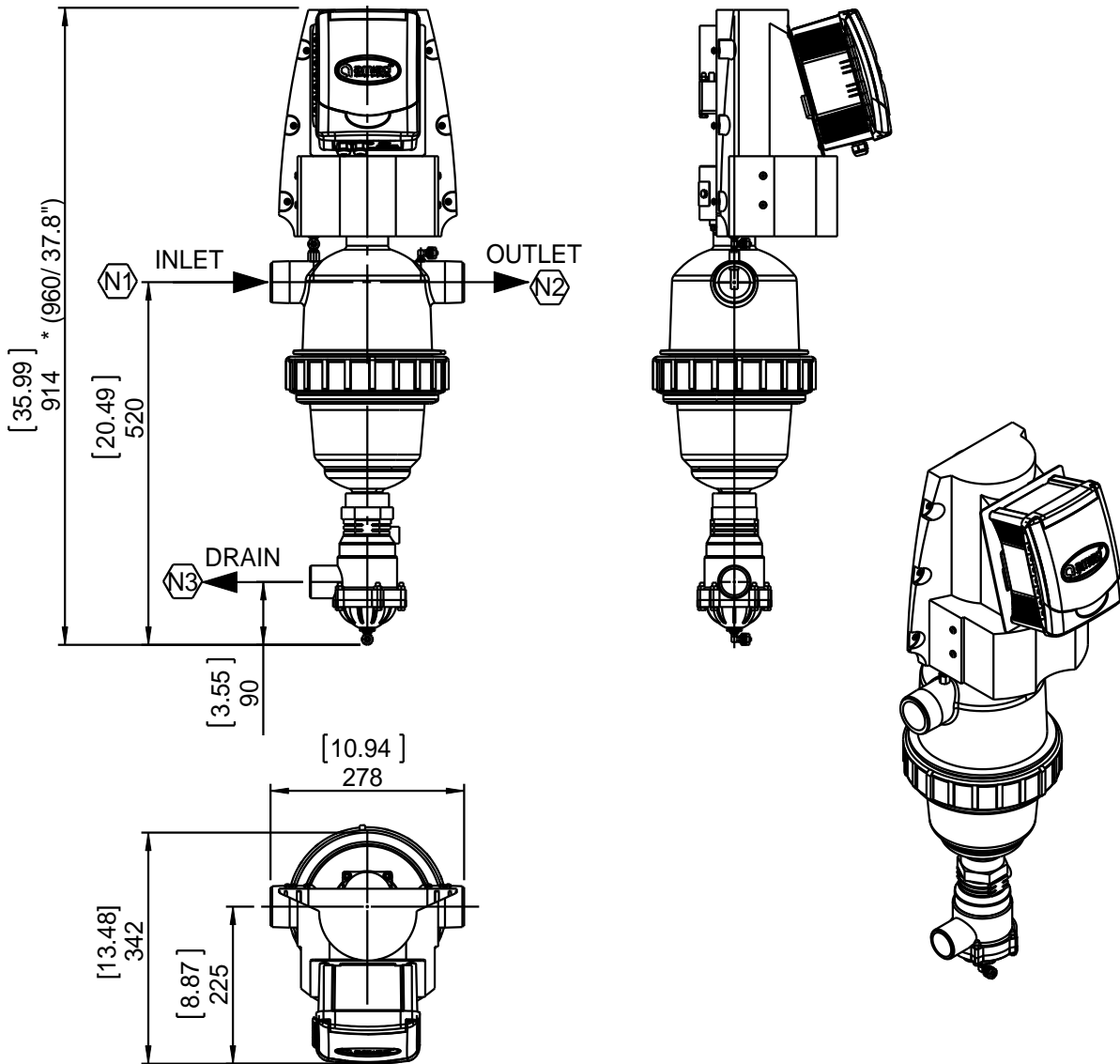

* Approx. Required Height For Maintenance

DESCRIPTION OF FILTER OPERATION

The "TAF" is a sophisticated yet easy-to-operate automatic electric filter, with a self-cleaning mechanism driven by an electric motor. The filter is designed to work with various types of screens in filtration degrees from 500 to 10 micron.

Filtering process

The water enters through the inlet pipe into the screen area and flows through the screen from inside out. The "filtration cake" is accumulated on the screen surface and causes head loss to develop.

Self-cleaning process

The TAF initiates the self-cleaning process either when the pressure differential across the screen reaches a pre-set value or after a predetermined lapse of time.

The fine screen filter element is cleaned by the suction scanner whose nozzles spiral across the inner surface of the screen. The filtration cake is "vacuumed" from the screen and expelled out the exhaust valve.

The scanner's spiral motion is achieved by a drive unit which rotates a bi-directional continuous worm shaft.

The exhaust valve is activated for the duration of the cleaning cycle by a 3-way solenoid. Filtered water continues to flow downstream during the flush cycle, which takes approximately 16 seconds.

INSTALLATION

Design recommendations

1. The filter requires 4 m³/h (26USgpm) for flushing, in addition to the working flow rate at a minimum pressure of 1.5 bar (22 psi). In the event that the system cannot provide the flushing flow in addition to the working flow, at the minimum required pressure, a hydraulic valve should be installed downstream of the filter. This valve will be closed during the flushing process in order to ensure sufficient cleaning.
2. Do not allow water to flow in opposite direction. In case that there is a chance of back flow a non-return check valve should be installed downstream of the filter.

Installation instructions

1. Install a manual valve upstream of the filter to enable convenient maintenance.
2. The diameter of the inlet pipe must not be smaller than that of the filter inlet.
3. Install the filter in a way that enables convenient approach and enough space to dismantle the filter for maintenance purposes.
4. It is recommended to install the filter horizontally, especially if the water contains sand.
5. Ensure the direction of flow is according to the arrows marked on the filter housing.
6. The exhaust valve can be facing downwards or sideways. Connect a minimum of 1.5" (40 mm) pipe to the exhaust valve using a detachable connector or a flexible pipe. The exhaust pipe should be designed so that it creates minimal resistance to the flow of 4 m³/h (26USgpm).
7. If the system is designed to operate with a working pressure higher than 6 bar (85 psi), it is recommended that a manual valve will be installed on the exhaust pipe, to enable regulation of the flushing flow rate.

START- UP AND FIRST OPERATION

1. Set the controller to 16 seconds flushing time and 2-4 hour intervals.
2. Operate a "dry" flushing cycle. Verify proper operation of the controller, the motor and the solenoid valve.
3. Open the inlet valve to the filter, while the outlet valve remains closed or with an open by-pass valve (This will keep the flow in the filter at a minimum), and operate a flushing cycle by pressing the push-button on the controller panel.
4. Make sure the exhaust valve opens and all stages of the flushing cycle are carried out. Attend to leakage, if any. If necessary, change the time setting to ensure complete up and down motion of the suction scanner.
5. Gradually open the outlet valve and/or close the by-pass valve. Operate the filter at the designed hydraulic conditions.

MAINTENANCE

NOTE: Depressurize the filter before maintenance (Close inlet and then outlet valves).

Checking the filter

1. Unscrew the filter cover.
2. Extract the screen and clean if necessary. Cleaning is performed by hosing the screen from outside-in, and/or with a nylon brush.
3. Check the Screen O-ring (17.1) and apply grease, if necessary.
4. Replace the screen.
5. Return the cover and twist to tighten.

Checking the PD switch connectors

Check the L-Connectors (9.3, 9.4) to the PD Switch to make sure that there are no obstructions.

Winterization

Filter operations should be suspended in climates where the filter is exposed to freezing temperatures.

1. Check that the outlet valve is closed and perform two manual rinses.
2. Close the inlet valve to the filter and release the pressure.
3. Remove all drain lines from the valves, drain, and reconnect.

Leaks

In case of a leak contact Amiad technical support.

PARTS SCHEDULE 2" TAF-500 FILTER Section 1

NO.	Cat. Num.	Description	QTY	Material
1	710103-001202	Housing 2" TAF-500/750 NPT	1	NYLON
1	710103-001200	Housing 2" TAF-500/750 BSPT	1	NYLON
2	700190-001831	Pressure Balancing Assembly 2" TAF Electric	1	Various
2.1	770102-000092	O-Ring Seal P2-125 Scanner Bearing NBR"S"	1	NBR
3	700190-001848	Suction Scanner (2" TAF)	1	Various
4	SEE TABLE	Screen TAF-500	1	Various
4.1	770102-000130	O-Ring Seal P2-242 (2"/3 Screen) NBR"S"	2	NBR
5	770102-000169	O-Ring Seal P2-437	1	NBR
6	710103-000545	Lid 2" T BSPT	1	NYLON
7	710103-000544	Tightening nut (T filters)	1	NYLON
8	770102-000069	O-Ring Rubber Seal P2-028	1	NBR
9	710103-000704	Long Bearing For Suction Scanner 2" T	1	Delrin
10	770102-000096	O-Ring Seal P2-129 NBR	1	NBR
11	780101-000955	Connector 1 1/2" FX 1 1/2" M	1	ST.37-2
12	730103-000444	1-1/2" Exhaust Valve	1	Various
13	720501-000198	L-Connector 1/4" X 8MM Red/Black	6	NYLON
14	720501-000232	T-Connector 8MM X 8MM X 1/4" M Black-Red	1	PP
15	730110-000034	Finger Filter	1	Various
16	710101-000765	Motor Connecting Flange 2" TAF NPT	1	NYLON
16	710101-000760	Flange Adaptor (HYDROTAF)	1	NYLON
17	760103-000094	Flat Washer M6 DIN125S/ST316	12	SST316
18	760101-000445	Hex Bolt Full Thread M6X25 S/ST316 DIN933	4	SST316L
19	710103-001207	Endless Worm Shaft Housing TAF	1	Delrin
20	770101-000051	O-Ring Seal 3.5X45 TAF Motor Housing NBR	1	NBR
21	710101-000767	Seal U-Cup (Scanner Shaft) Hydro-TAF	1	NBR
22	770101-000049	O-Ring Seal 30X3 NBR "S"	1	NBR
23	710103-001247	Reversible Worm Shaft	1	Acetal
24	760105-000029	Slotted Pin 3x20 DIN1481 S/ST 304	1	S/ST 304
25	710103-001209	Endless Worm Shaft Tooth	1	S/ST 303
26	760107-000065	Spring Tooth S/St302	1	Hastelloy C-276
27	710103-001210	Tooth Cover TAF	1	S/ST 316L
28	760101-000443	Hex Bolt Full Thread M6X15 S/ST304 DIN933	4	SST304
29	710103-001216	Motor Shaft Coupler	1	S/ST 316L
31	710103-001217	Drive Unit Basis TAF	1	S/ST 316L
32	720201-000033	Drive Unit TAF-750 220V AC 1/25	1	Various
32	720201-000032	Drive Unit TAF-750 110V AC 60HZ 0.015KW 1/25	1	Various
33	760101-000607	Hex Bolt Full Thread M6X60 S/ST316 DIN933	4	SST316L
34	760102-000085	Hex Nut M6 S/ST316 DIN934	4	SST316L
35	710103-001212	Instrumentation Bracket	1	S/ST 316L
36	720104-000029	PD Switch UE 24-011	1	Various
37	760101-000529	Phillips Pan Machine Screw M4X10 316	2	SST316L
38	760102-000083	Hex Nut M4 S/ST304 DIN934	2	SST304
39	720103-000187	3/2 Nc Solenoid Valve (Type B) 24VAC 50Hz	1	Various
39	720103-000189	3/2 NC Solenoid Valve 60HZ NC 24VAC	1	Various
40	720501-000209	L-Connector 1/8" MX6MM Black-Red	1	PP
41	710103-001204	Drive Unit Cover TAF	1	Various
42	710103-004837	Sling For AMIAD Controller AC-DC6_GL-TAF	1	S/ST 304L
43	720101-000475	Electronic Control 220VAC 6-Out 1-In Galcon	1	Various
43	710101-000476	Electronic Control 110VAC 6-Out 1-In Galcon	1	Various
44	760101-000713	Phillips Pan Machine Screw M5X8 S/ST316	4	SST316L
45	760101-000530	Phillips Pan Machine Screw M5X8 304	4	SST304
46	770101-000036	MM O-RING SEAL ID10MM TH2MM NBR 70 SHORE	1	NBR

PARTS DRAWING TAF-500 FILTER Section 1

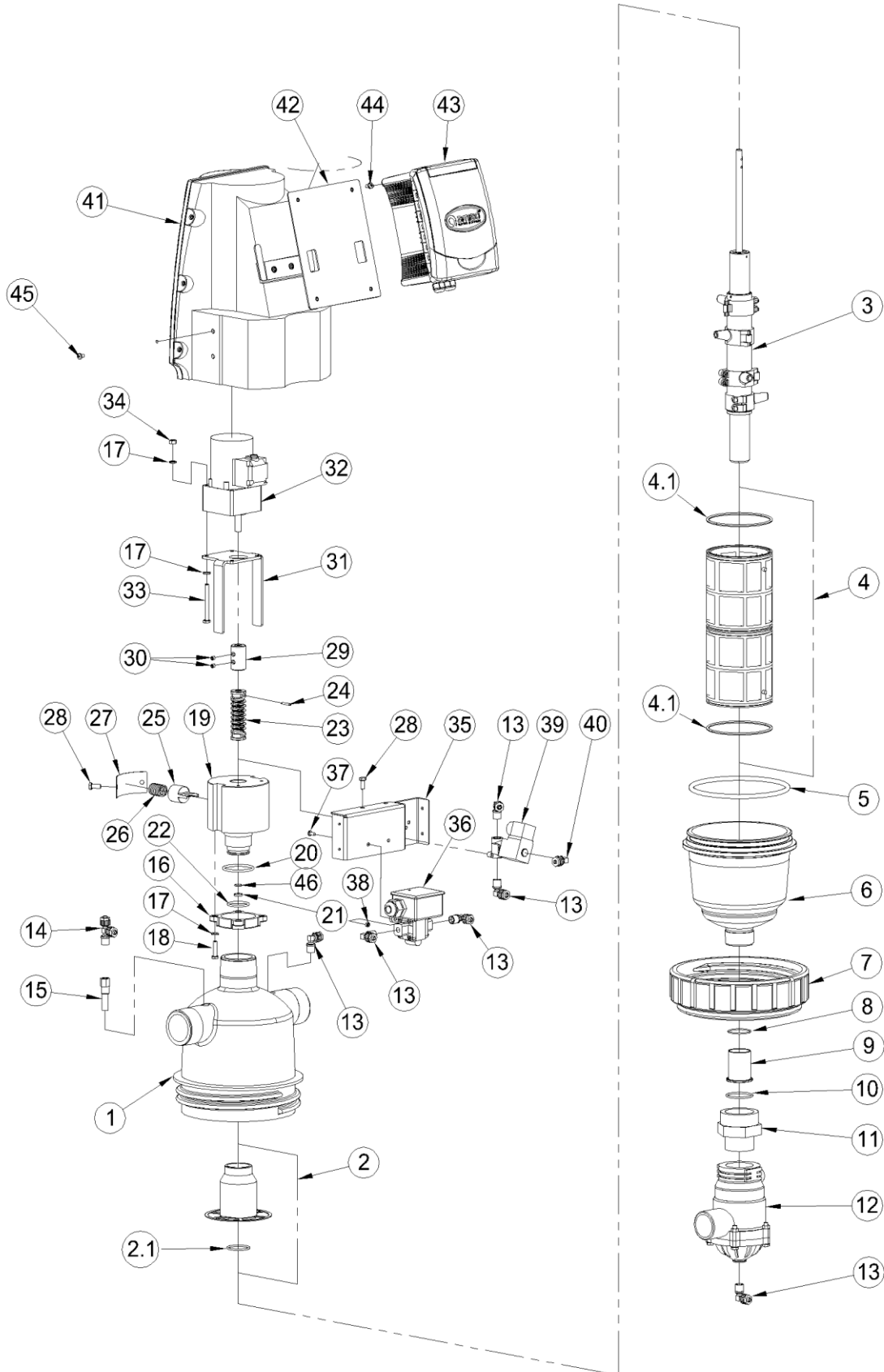

PARTS SCHEDULE & DRAWING 2" TAF-500 FILTER Section 2

NO.	Cat. Num.	Description	QTY	Material
1	700190-001850	Suction Scanner W/O Shaft (2" TAF-500)	1	Various
1.1	710101-000751-1	2"-4" Suction Scanner Nozzle No.1	4	PP
1.2	710101-000751-2	2"-4" Suction Scanner Nozzle No.2	4	PP
1.3	760101-000537	Phillips Pan Tap Screw PT4x20 S/ST316	8	S/ST 316
2	710103-001208	Suction Scanner Shaft 2" TAF	1	S/ST 316L
3	760105-000033	Slotted Pin 3x30 DIN1481 S/ST 304	1	S/ST 304

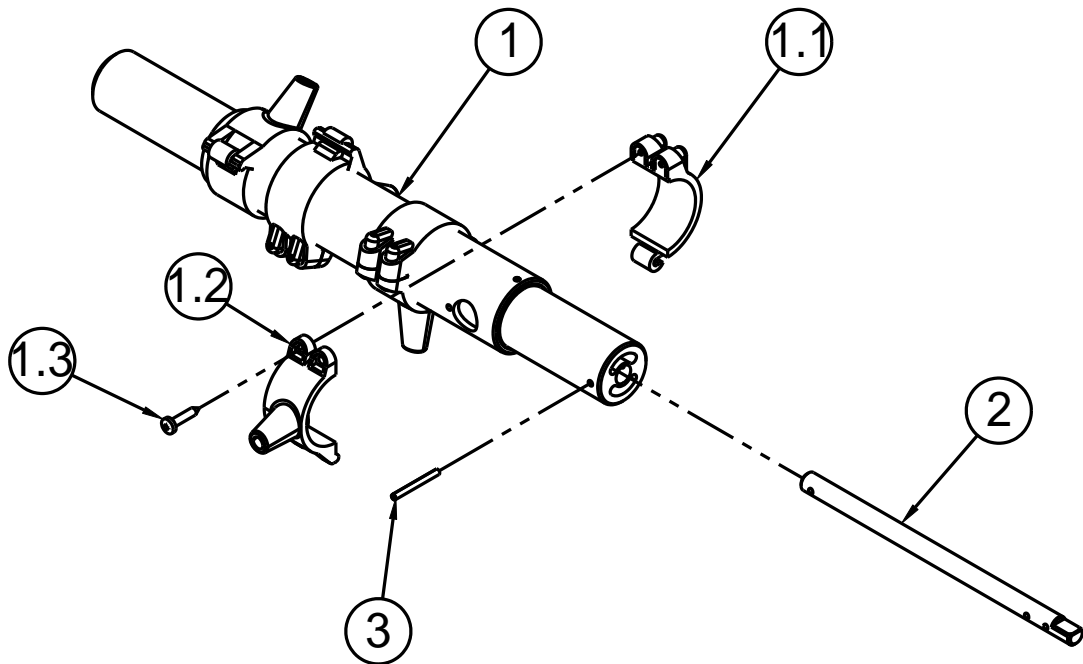

CONTROL DRAWING

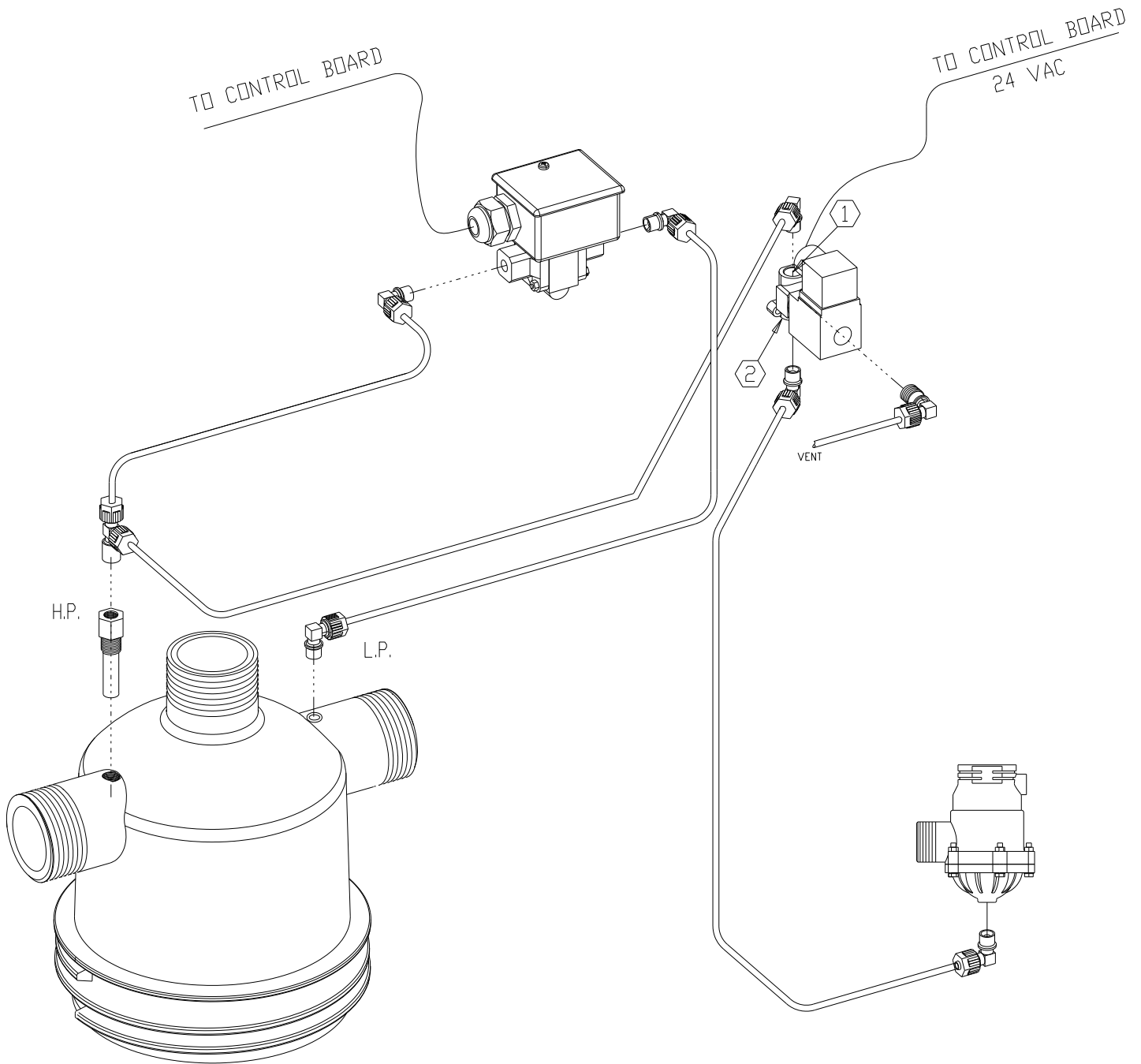

Amiad Limited Warranty

This certificate applies to Amiad Products purchased by You from Amiad or an Amiad authorized Distributor (“**Distributor**”). This limited warranty extends only to the original purchaser, and is not transferable to anyone who subsequently purchases, leases, or otherwise obtains the Product from the original purchaser.

1. Amiad hereby warrants that the Products are and will be free from defects in material and workmanship under normal use and service. Amiad warrants that it will correct manufacturing defects in the Products, in accordance with the conditions set out in this warranty.
2. This warranty is enforceable for a period of 12 months after the date Bill of Lading or equivalent (the “**Warranty Period**”).
3. In the event that during the Warranty Period the Distributor discovers a defect in material and/or workmanship in any Product or part (the “**Defective Product**”), it shall submit a written complaint to Amiad using Amiad's standard customer complaint form. For the receipt of the customer complaint form, the submission of the complaint or any questions please contact your customer service representative.
4. Upon written demand by Amiad the Distributor shall return the Defective Products – or a sample thereof – to Amiad, at Amiad's cost. If the customer ships any such Product, Amiad suggests the customer package it securely and insure it for value, as Amiad assumes no liability for any loss or damage occurring during shipment. Provided however that in the event Amiad determines that the warranty does not apply to such Product, Distributor shall promptly reimburse Amiad for such cost (including freight and customs). Any returned Product or part must be accompanied by the warranty certificate and the purchase invoice. It is clarified that the Distributor may not return the Defective Product unless such return was coordinate and approved by Amiad in advance.
5. Amiad's obligation under this warranty shall be limited to, at its option, the repair or exchange, free of charge, of the Product or any part which may prove defective under normal use and service during the Warranty Period. The provision of a repaired or replacement Product during the Warranty Period will result in an extension of the Warranty Period by an additional period of 12 months, provided that the total accumulated Warranty Period shall in any event be no more than 18 months from the original Bill of Lading.
6. This warranty is valid on the condition that the Products are installed according to Amiad's instructions as expressed in Amiad's instruction manuals and according to the technical limitations as stipulated in Amiad's literature or as stated by a representative of Amiad.
7. This warranty will not apply to damaged or defective Products resulting from or related to:
 - (i) Fire, flood, power surges or failures or any other catastrophe/and or unforeseen occurrence, such as but not limited to those for which the customers are customarily insured;
 - (ii) Fault, abuse or negligence of the customer;
 - (iii) Customer's responsibilities, including the failure of the intake water to meet the agreed standards, as set forth in a written document, approved by Amiad or improper storage.
 - (iv) Improper or unauthorized use of the Product or related parts by the customer, including the customer's failure to operate the Product in conformity with the recommendations and instructions of Amiad, as set forth in Amiad's manuals and other written materials, the operation of the Product other than by a trained and qualified operator, or improper installation of the Product by a third party not authorized by Amiad;
 - (v) Performance by the customer of maintenance and other services other than by a trained and qualified advanced operator, or other than in conformity with the recommendations and instructions of Amiad, or other than in accordance with procedures defined in the literature supplied for Products;
 - (vi) Any alteration, modification foreign attachment to or repair of the Products, other than by Amiad or its authorized technical representatives.
8. In no event shall Amiad be liable to the customer or any third party for any damages, including indirect, special, exemplary, punitive or consequential damages, or lost profits arising out of or in connection with this warranty, or arising out of or in connection with the Product's performance or failure to perform, even if it has been advised of the possibility of such damages.
9. Amiad will be excused for failure to perform or for delay in performance hereunder if such failure or delay is due to causes beyond its reasonable control or force majeure preventing or hindering performance.
10. The limited warranty set forth herein is the only warranty given by Amiad and is provided in lieu of any other warranties created by any documentation, packaging or otherwise.
11. Amiad makes no warranty whatsoever in respect of accessories or parts not supplied by Amiad. In the event that Amiad is required to correct a defective Product or product not covered by this warranty, it will do so solely in consideration for additional fees.



Headquarters: 54/18 Bui Quang La, Ward 12, Go Vap District, HCMC, Viet Nam
Office: 12 DHT10B, Dong Hung Thuan Ward, District 12, HCMC, Viet Nam
Phone: (028) 6258 5368 - (028) 6291 9568
Email: info@atswatertechnology.com
Website: www.atswatertechnology.com



Amiad Water Systems Ltd. D.N. Galil Elyon 1, 1233500, Israel

Tel: +972 4690 9500 | Fax: +972 48141159 | Email: info@amiad.com

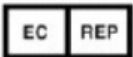

Obelis s.a. Bd Général Wahis 53, 1030 Brussels, Belgium.

Tel: +(32) 2732 5954 | Fax: +(32) 27326003 | Email: mail@obelis.net

EC Declaration <http://amiad.com/certificatesDownload.asp>