

DWG REF	QTY	PART NUMBER	DESCRIPTION	MATERIAL
SHELL				
1	1	99218	SHELL	Filament Wound Epoxy/Glass composites - Head locking grooves integrally wound in place.
2	A/R	A/R	F/C Port	SA-351 CF3M
3	A/R	A/R	F/C Port Seal	Ethylene Propylene .
HEAD - NON CODED				
4	2	96243	Elliptical Head Assy.	Engineering Thermoplastic.
5	2	96000	Head Seal	Ethylene Propylene - O - Ring
HEAD INTERLOCK				
6	2	47336	Quick Release Spiral Ring	SA-479 316
VESSEL SUPPORT				
7	2*	52169	Saddle	Engineering Thermoplastic.
8	2*	45042	Strap Assy.	304 Stainless Steel-PVC Cushion.
9	4	46265	Strap screw.	5/16-18 UNC, 2.5" L, 18-8 Stainless Steel.
ELEMENT INTERFACE				
10	2	A/R	Adapter	Engineering Thermoplastic.
11	2	52245	Adapter seal	Ethylene Propylene - O - Ring
12	4	A/R	PWT Seal	Ethylene Propylene - O - Ring
13	1	97014	Thrust Cone	Engineering Thermoplastic.
+ 3 each furnished with length code 4,5,6,7 & 8.				

VIEW AT CENTER SUPPORT
 CENTER VESSEL ON 2 OR 3 SUPPORTS
 AT SPAN(S) "S" : 3 SUPPORTS REQUIRED
 FOR LENGTHS -4 AND OVER

PORT SIZE CODE	
D	1 1/2" GROOVED END
E	2" GROOVED END
F	2 1/2" GROOVED END

CAUTION: INCORRECT MANIFOLDING WILL CAUSE SEVERE LOCAL STRESS AROUND PORT AND MAY RESULT IN LEAKS AND PREMATURE FAILURE; TAKE EVERY PRECAUTION LISTED ON REVERSE. SEE INSTALLATION INSTRUCTIONS FOR FURTHER DETAILS

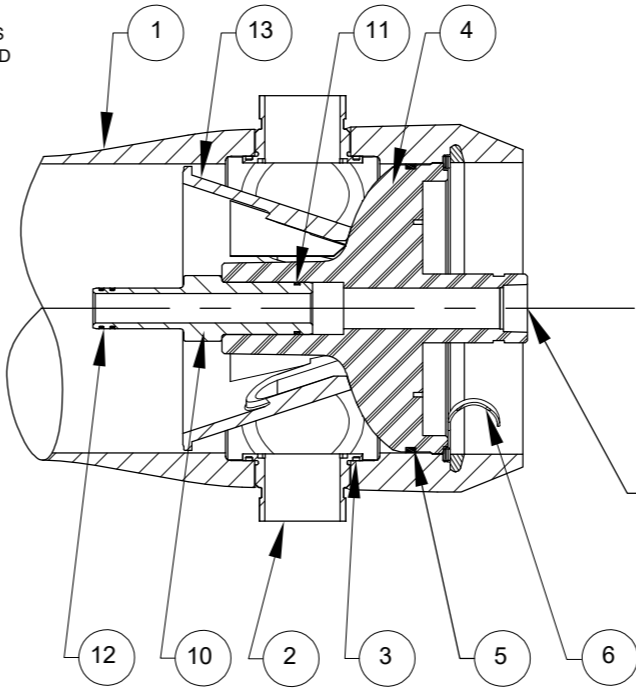

SECTION THROUGH END CLOSURE

WARNING INTERNAL PORT PRESSURE NOT TO EXCEED 125 PSI.

NO. OF PORTS	PORT LOCATION			VESSEL QTY.
Dash Length	L IN(MM)	P IN(MM)	S IN(MM)	Approx Weight LB(KG)**
-1	59.15 (1502)	47 (1194)	23X1 (584)	66 (30)
-2	99.15 (2518)	87 (2210)	56X1 (1422)	75 (34)
-3	139.15 (3534)	127 (3226)	80X1 (2032)	88 (40)
-4	179.15 (4550)	167 (4242)	64X2 (1626)	101 (46)
-5	219.15 (5566)	207 (5258)	78X2 (1981)	110 (50)
-6	259.15 (6582)	247 (6274)	92X2 (2337)	126 (57)
-7	299.15 (7598)	287 (7290)	106X2 (2692)	137 (62)
-8	339.15 (8614)	327 (8306)	120X2 (3048)	152 (69)

GENERAL NOTES:
 1. MAX. ANGULAR VARIATION BETWEEN ANY PORT ±0.5°.
 2. DIMENSION IN INCHES (MM APPROX.).
 3. SHELL EXTERIOR COATED WITH WHITE RAL 9003, HIGH GLOSS POLYURETHANE PAINT.
 4. ITEM 13 DOWNSTREAM ONLY.
 5. NOT TO BE USED FOR CONSTRUCTION UNLESS CERTIFIED BY PENTAIR.
 ** WEIGHTS GIVEN IN THE TABLE ARE FOR HIGHEST CONFIGURATION AND WILL VARY WITH CHANGE IN CONFIGURATION.

THIS DOCUMENT AND THE INFORMATION CONTAINED HEREIN, ARE THE CONFIDENTIAL AND PROPRIETARY INFORMATION OF PENTAIR INDIA PVT. LTD. PENTAIR INDIA PVT. LTD. IS THE SOLE OWNER OF THE INFORMATION AND PROCESSES DEFINED HEREIN. THIS DOCUMENT, AND THE INFORMATION CONTAINED, MAY NOT BE DISCLOSED, REPRODUCED, DUPLICATED, USED, SOLD, PUBLISHED, COMMUNICATED OR OTHERWISE DISTRIBUTED, IN WHOLE OR IN PART, FOR ANY PURPOSE WITHOUT THE EXPRESS WRITTEN CONSENT OF PENTAIR INDIA PVT. LTD. THIS DOCUMENT AND ANY COPIES, IN ALL APPLICABLE FORMATS, SHALL BE RETURNED TO PENTAIR INDIA PVT. LTD. UPON REQUEST.

ALL INDICATED PENTAIR TRADEMARKS AND LOGOS ARE PROPERTY OF PENTAIR. THIRD PARTY REGISTERED AND UNREGISTERED TRADEMARKS AND LOGOS ARE PROPERTY OF THEIR RESPECTIVE OWNERS. BECAUSE WE ARE CONTINUOUSLY IMPROVING OUR PRODUCTS AND SERVICES, PENTAIR RESERVES THE RIGHT TO CHANGE SPECIFICATIONS WITHOUT PRIOR NOTICE. PENTAIR IS AN EQUAL OPPORTUNITY EMPLOYER.

VERNA, GOA INDIA

DRAWN BY: RA	DATE: 15/09/21	DRAWING DESCRIPTION: MODEL - 80S30 NC MEMBRANE HOUSING	DRAWING NO.: 99172	REV.: T
CHECKED BY: KPS	DATE: 15/09/21	CUSTOMER NAME:	VESSEL MODEL: 80S30 (NON-CODED)	
APPROVED BY: FF	DATE: 15/09/21	PROJECT NAME:	TOTAL QTY: -	
ECN NO.: 5761	DATE: 09/12/21	CUSTOMER P.O.#:	SIZE: A3	SCALE: NONE
			PAGE NO.: 01	OF 02

RATING:

DESIGN PRESSURE.....300 PSIG
(2.1MPa)
MAX OPERATING TEMP.....190°F
(88°C)
MIN. OPERATING TEMP.....20°F
(-7°C)
FACTORY TEST PRESSURE.....450 PSIG
(3.1 MPa)

QUALIFICATION PRESSURE1800 PSI
(12.4 MPa)

INTENDED USE:

The CodeLine 80S30 Non Coded Fiberglass RO Pressure Vessel is designed for continuous, long term use as a housing for reverse osmosis membrane elements to desalt typical brackish waters at pressures up to 300 psi. Any make of eight-inch nominal diameter spiral-wound element is easily accommodated; the appropriate interfacing hardware for the element specified is furnished with the vessel.

The Shell of CodeLine 80S30 Non Coded vessel is designed in accordance with the engineering standards of the Boiler and Pressure Vessel Code of the American Society of Mechanical Engineers (ASME) as per Section X. ASME Edition 2021 and all metallic parts are designed as per section ASME VIII Division I Edition 2021

The CodeLine 80S30 Non Coded vessel must be installed operated and maintained in accordance with the listed precautions and good industrial practice to assure safe operation over a long service life.

The high performance Filament wound FRP shell must be allowed to expand under pressure; undue restraint at support points or piping connections can cause leaks to develop in the shell. This side-ported vessel requires special precautions in mounting and connection to piping so that the vessel will not be subjected to excessive stress due to bending moments acting at the side openings in the fiberglass shell. The end closure, incorporating close fitting, interlocking metal components, must be kept dry and free of corrosion; deterioration can lead to catastrophic mechanical failure of the head.

Pentair will assist the purchaser in determining the suitability of this standard vessel for their specific operating conditions. The final determination however, including evaluation of the standard material of construction for compatibility with the specific corrosive environment, shall be the responsibility of the purchaser. Alternate materials with enhanced corrosion resistance are available on special order.

Specifications are subject to change without notice.

PRECAUTIONS:

- DO...read, understand and follow all instructions; failure to take every precaution will void warranty and may result in vessel failure
- DO...mount the shell on horizontal members at span "S" using compliant vessel supports furnished; Shim saddles if required. Tighten hold down straps just snug
- DO...align and center side ports with the manifold header. Correct, causes of misalignment in a row of vessels connected to the same header
- DO...use flexible type IPS grooved-end pipe couplings, at side ports; allow full, 0.125 inch gap between port and piping, and position piping to maximize flexibility of connection.
- DO...provide flexibility in, and support for piping manifolds so that vessel can grow in length under pressure without undue restraint; provide additional flexible joints in large pipes leading to manifold header.
- DO...provide overpressure protection for vessel set at not more than 105% of design pressure
- DO...inspect end closures regularly; replace components that have deteriorated and correct causes of corrosion
- DO... Lubricate seals sparingly, using nonpetroleum Based lubricants, i.e. Parker Super O-lube®, Glycerin or suitable silicone based lubricants.

- DO NOT...work on any component until first verifying that pressure is relieved from vessel
- DO NOT...make rigid piping connections to ports or clamp vessel in any way that resists growth of fiberglass shell under pressure;
***ΔDIA = 0.015 in. (0.4mm) and
***ΔL = 0.2 in. (6mm) for a length code -8 vessel
- DO NOT... hang piping manifolds from ports or use vessel in any way to support other components
- DO NOT...tighten Permeate Port connection more than one turn past hand tight
- DO NOT... operate vessel without connecting both Permeate Ports internally to complete set of elements or otherwise plug ports internally so that external piping connection is not subjected to feed pressure
- DO NOT...install Spacer on downstream end of vessel
- DO NOT...operate vessel without Thrust Cone installed downstream
- DO NOT...pressurize vessel until double-checking to verify that the Locking Ring is in place and fully seated.
- DO NOT...operate vessel at pressure and temperature in excess of its rating.
- DO NOT...operate vessel with permeate pressure in excess of 125 psi at 190°F (0.86 Mpa at 88°C).
- DO NOT...tolerate leaks or allow end closures to be routinely wetted in any way
- DO NOT...operate outside the pH range 3-11.

ORDERING:

Using the chart below, please check the features you require

VESSEL LENGTH CODE – please check one

MODEL 80S30 Non Coded -1 -2 -3 -4 -5 -6 -7 -8

MEMBRANE BRAND AND MODEL

Please supply adapters for the following membrane brand and specific model
Brand _____ Model _____

CERTIFICATION REQUIRED

- CE Marked Standard.
- Certified by Pentair.

ADAPTER KITS	
UP STREAM	DOWN STREAM

PERMEATE PORT CONFIGURATION:

- Standard. 1" FNPT & 1.5" IPS GROOVED NORYL HEAD.
- Optional .1" BSP F/JIS F Parallel Thread & 1.5" IPS GROOVED NORYL HEAD.

STRAP ASSEMBLY

Standard SS304 Optional SS316 Optional SS316L

STRAP ASSEMBLY PART NUMBERS		
SS304	SS316	SS316L
45042	46926 ⁺	94371 ⁺

FEED/CONCENTRATE PORT SELECTION

Material of Construction Standard CF3M Optional Duplex SS (CD3MN)
 Optional Super Duplex SS (CD3MWCuN)

Configuration Standard - CF3M 1D5D

Optional – Multi ports:

Serial number end

Opposite end

F/C PORT & SEAL PART NUMBER				
SIZE	*CF3M	**CD3MN	***CD3MWCuN	SEAL
1.5"	98024	97353	96507	96077
2.0"	98025	97357	96643	96078
2.5"	98026	97364	96556	96079

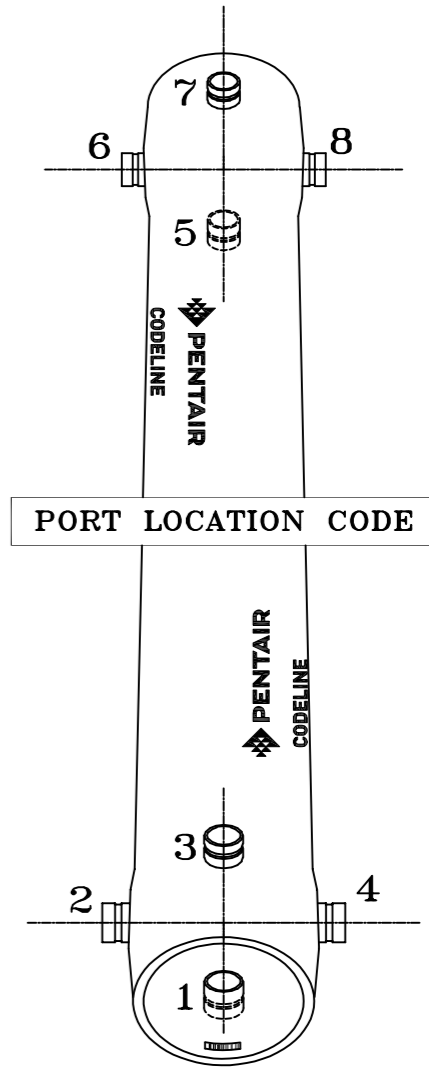

CODELINE BODY LABELS ARE PLACED AT 90° ON SERIAL NUMBER END AND AT 270° ON THE OPPOSITE SIDE END

THIS DOCUMENT AND THE INFORMATION CONTAINED HEREIN, ARE THE CONFIDENTIAL AND PROPRIETARY INFORMATION OF PENTAIR INDIA PVT. LTD. PENTAIR INDIA PVT. LTD. IS THE SOLE OWNER OF THE INFORMATION AND PROCESSES DEFINED HEREIN. THIS DOCUMENT, AND THE INFORMATION CONTAINED, MAY NOT BE DISCLOSED, REPRODUCED, DUPLICATED, USED, SOLD, PUBLISHED, COMMUNICATED OR OTHERWISE DISTRIBUTED, IN WHOLE OR IN PART, FOR ANY PURPOSE WITHOUT THE EXPRESS WRITTEN CONSENT OF PENTAIR INDIA PVT. LTD. THIS DOCUMENT AND ANY COPIES, IN ALL APPLICABLE FORMATS, SHALL BE RETURNED TO PENTAIR INDIA PVT. LTD. UPON REQUEST.

ALL INDICATED PENTAIR TRADEMARKS AND LOGOS ARE PROPERTY OF PENTAIR. THIRD PARTY REGISTERED AND UNREGISTERED TRADEMARKS AND LOGOS ARE PROPERTY OF THEIR RESPECTIVE OWNERS. BECAUSE WE ARE CONTINUOUSLY IMPROVING OUR PRODUCTS AND SERVICES, PENTAIR RESERVES THE RIGHT TO CHANGE SPECIFICATIONS WITHOUT PRIOR NOTICE. PENTAIR IS AN EQUAL OPPORTUNITY EMPLOYER.

©2021 Pentair. All Rights Reserved.



DRAWN BY: RA	DATE: 15/09/21	DRAWING DESCRIPTION: MODEL - 80S30 NC MEMBRANE HOUSING	DRAWING NO.: 99172	REV.: T
CHECKED BY: KPS	DATE: 15/09/21	CUSTOMER NAME: -	VESSEL MODEL: 80S30 (NON-CODED)	
APPROVED BY: FF	DATE: 15/09/21	PROJECT NAME: -	TOTAL QTY: -	
ECN NO.: 5761	DATE: 09/12/21	CUSTOMER P.O.#: -	SIZE: A3	SCALE: NONE
			PAGE NO.: 02	OF 02