

The RK400-01 Tipping Bucket Rainfall Sensor is an instrument for testing rainfall in the nature. In order to meet the requirement of information transmission, processing, recording and display, the amount of rainfall is converted to pulse output. It can be widely used in weather stations, hydrometric stations, agriculture & forestry, defense & field monitoring stations. It can provide the original data for flood-prevention, water-supply system, and reservoir water management in plant.

FEATURES

- According to WMO No.8 , No.168
- High accuracy, good stability
- Mesh in the funnel preventing debris such as leaves and insects from entering the working of rain sensor(mesh is optional)
- Well made tipping bucket with low resistance
- Highly polished stainless steel construction
- Horizontal Bubble in the bottom
- Rain collector with filter, to prevent the leaves, such as debris jam over the hole
- Optional heating function in cold region



APPLICATIONS

- Water supply system
- Hydrologic monitoring
- Natural disaster monitoring
- Agro-meteorological research
- Climate research

SPECIFICATIONS

Item	Specification
Rainfall collector	Diameter : ϕ 200mm \pm 3mm. height: 350mm
Measured rainfall intensity	Max: 150mm/hour
Allow rainfall intensity	Max: 10mm/min
Resolution	0.2mm
Accuracy(150mm/hour)	\pm 2%
Maximum load voltage	30VDC(pulse output)
Maximum load current	20mA(pulse output)
Output	Reed switch pulses,RS485 to Data logger
Operating temperature(no freeze)	-20-+80 $^{\circ}$ C
Main material (UV Protection)	Collector:304SS,tipping bucket:ABS ,IP67

RK400-01 Tipping Bucket Rainfall Sensor



www.rikasensor.com.cn

Tipping bucket	Single
Heating(optional)①	Heating power: approx.350W Heating voltage:220VAC
Collector filter	Removable filter (prevent leaves and sundries)optional
Weight(unpacked)	3.5kg

①According to user requirements,set heating start point and heated end point before leaving the factory.

WORKING PROCESS

Rainfall is captured in the 200mm diameter collector funnel and is directed through a delivery pipe to fill a divided ABS injection molded tipping bucket device. The bucket is pivoted through its center and has a preset calibration to tip for 0.2 mm of rainfall. When the bucket is “full”, it pivots and empties - this action magnetically closes and opens a reed switch, sending a pulse signal to the data logger or electronic counter. Through this tipping “seesaw” action, the other side of the bucket is aligned to receive the flow from the delivery pipe. This recording and tipping cycle continues with rainfall.

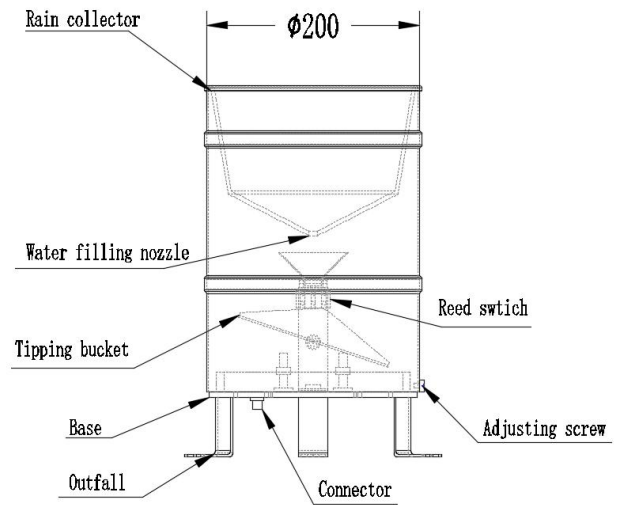

DIMENSION

Unit:mm

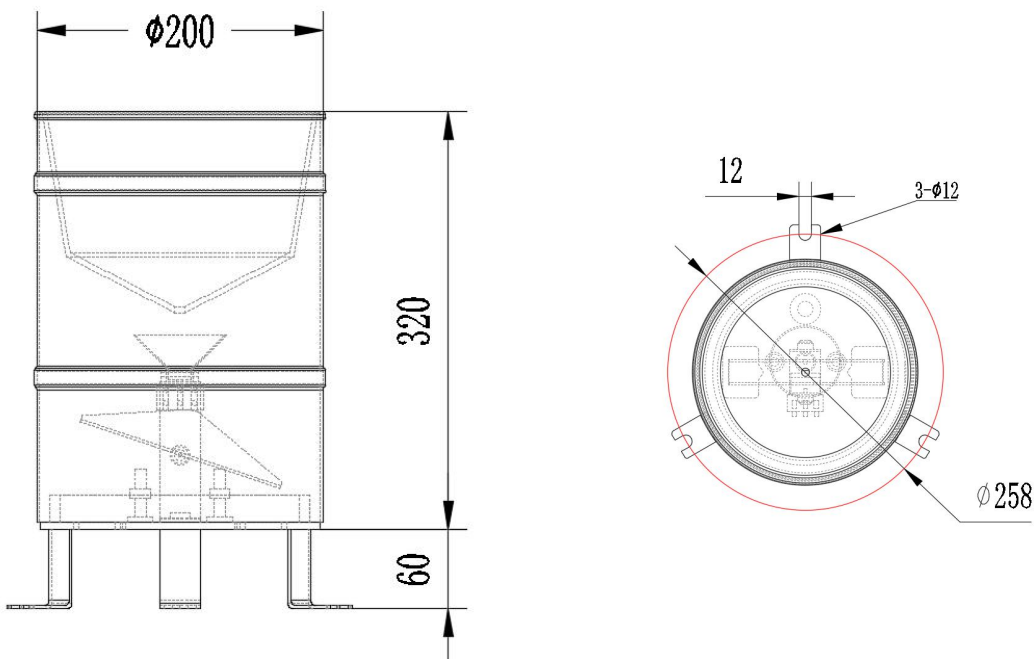

PARAMETER SELECTION TABLE

Remark	Series	Type	Output	Resolution	Heating	Filter	Cable Length	
RK								
	400							
		01						
			A					Pulse(Reed switch)
			B					RS485
			C					Customization
				A				0.2mm(default)
				X				Other
					A			Without heating
					B			With heating(independent cable)
						A		Without filter
						B		With filter
							1500	Units:mm (typ.)
							3000	Units:mm
							...	Units:mm

Example: RK400-01AAAA1500 Output:pulse, Resolution:0.2mm, Without heating,Without filter, Cable Length:1.5m.

Appendix:

Rainfall intensity scale	
Scale	24-hour rainfall(mm)
Light rain	1-9.9
Moderate rain	10-24.9
Heavy rain	25-49.9
Rainstorm	50-99.9
Torrential rain	100-200
Super-Torrential rain	>200

 Complies with applicable CE directives.

Specifications subject to change without notice. Version 3.0
Copyright © 2015 Hunan Rika Electronic Technology Co.,Ltd

Hunan Rika Electronic Technology Co., Ltd

Add:No 499# of Yingxin Road,
Yuhua District,Changsha,
Hunan,China



+86-731-85132979



info@rikasensor.com



www.rikasensor.com.cn