



# Y-TYPE AUTOMATIC DIAPHRAGM VALVE (NORMAL OPEN TYPE)



## YT Series

### YT100 SOCKET/YT200 THREADED YT300 FLANGED Size: 3/8" - 2"

Y type diaphragm valve operation instructions:

1. Valve Close Operation :

Air fill in from the cap's air hole and body's air hole clear out the air.

2. Valve Open Operation :

Fill air from the body's air hole and the cap's air hole clear out the air.

#### ● MATERIALS OF CONSTRUCTION

No.	Parts	Pcs.	Materials	No.	Parts	Pcs.	Materials
1	Body	1	PPS	11	Plate Screw	1	PVDF
2	Bonnet	1	PPS	12	Diaphragm	1	EPDM
3	Disc Plate Screw	1	PVDF	13	Bolt	6/8/12	SUS304
4	Disc	1	EPDM	14	Hex Nut	6/8/12	SUS304
5	Dynamic O'ring	1	EPDM	15	End Seal	2	PPO
6	Shaft	1	PVDF	16	Split Ring	2	EPDM
7	Shaft Guide	1	PPG	17	Retainer Nut	2	PPG
8	Shaft Seal	1	EPDM	18	Tube	2	UPVC
9	Body Seal	1	EPDM	19	Flange	2	UPVC
10	Diaphragm Hader	1	PVDF				

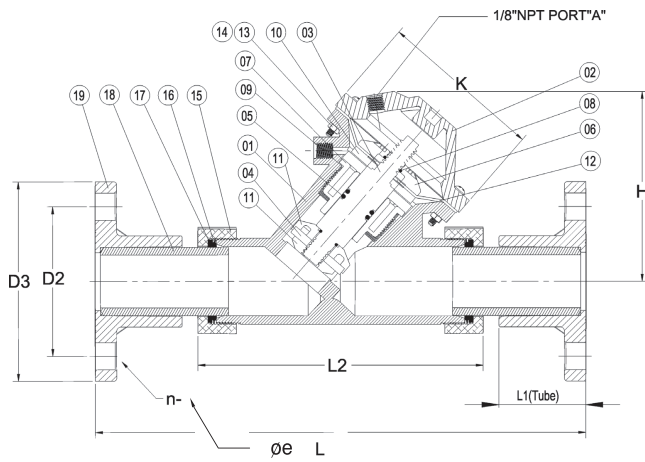

**FLANG TYPE**

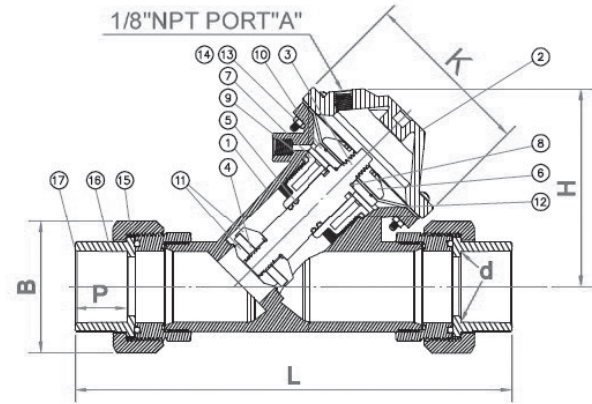

**SOCKET & SCREW TYPE**

Operation limits:

1. pressure : 3-8 kgf/cm<sup>2</sup>
2. 3 kgf/cm<sup>2</sup> air pressure can open the valve(from the body's air hole)
3. The max pressure place on the valve (fill air pressure + flow pressure) is 8 kgf/cm<sup>2</sup>
4. The inlet air preaaure from the cap's air hole must be higher than the flow pressure that can close the valve.

**DIMENSIONS TABLE**

Nom. Size DN(inch)	L2	L1	L	H	K	JIS Unit:mm				ANSI Unit:inch				DIN Unit:mm			
						D2	D3	n	øe	D2	D3	n	øe	D2	D3	n	øe
12(3/8")	100	70	198	65	63	65	90	4	15	2.38	3.50	4	0.63	60	90	4	14
15(1/2")	100	70	219	65	63	70	95	4	15	2.36	3.50	4	0.63	65	95	4	14
20(3/4")	100	80	238	65	63	75	100	4	15	2.75	3.88	4	0.63	75	105	4	14
25(1")	118	80	238	103	83	90	125	4	19	3.13	4.25	4	0.63	85	115	4	14
32(1-1/4")	118	90	332	103	83	100	135	4	19	3.50	4.63	4	0.63	100	140	4	18
40(1-1/2")	194	90	332	128	116	105	140	4	19	3.88	5.00	4	0.63	110	150	4	18
50(2")	194	90	350	128	116	120	155	4	19	4.75	6.00	4	0.75	125	165	4	18

※ Standard dimensions based on PVC material