

# Lab Cock Valves

- Material : PVC
- Size : 6mm - 13mm, 1/4" - 3/8"
- Pressure Rating : JIS 10kgf/cm<sup>2</sup>, 150 PSI
- Seals (Seat) : EPDM
- O-Ring : EPDM

- Connections  
 Hose : 6mm(1/4")  
 Male Thread : PT 1/4", PT 3/8", PT 1/2"  
 Female Thread : PT 1/4", PT 3/8"

## Special Features

- Full Port
- 간편한 조작성
- 양방향 흐름 제어 가능
- Ball Valve 종류에서 가장 작은 Size로 제작
- 다양한 형태의 Connections

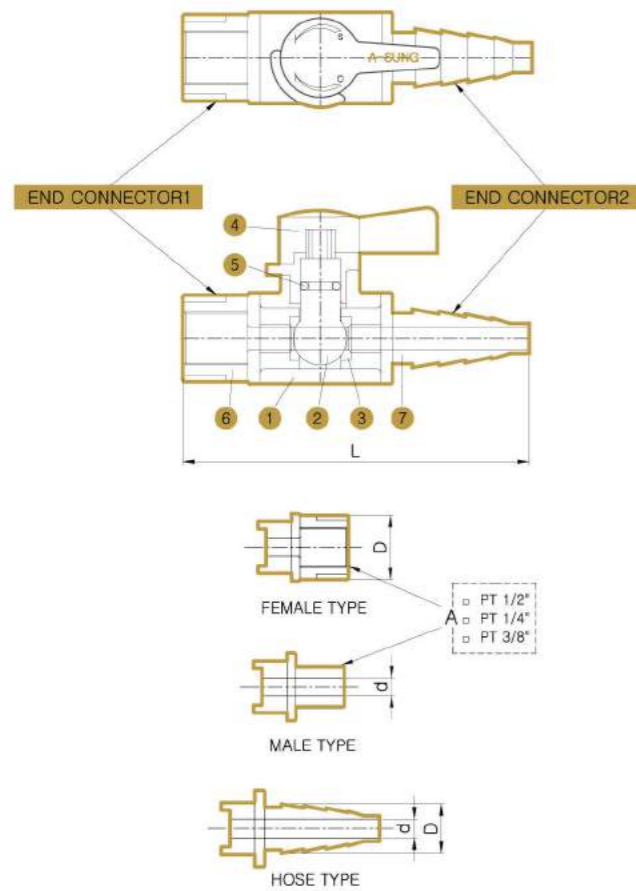

| NO | PARTS           | MATERIALS |
|----|-----------------|-----------|
| 1  | BODY            | PVC       |
| 2  | BALL & STEM     | PVC       |
| 3  | NIP SEAL        | EPDM      |
| 4  | HANDLE          | PP        |
| 5  | O-RING          | EPDM      |
| 6  | END CONNECTOR 1 | PVC       |
| 7  | END CONNECTOR 2 | PVC       |

## PVC

| Parts<br>Type   | D   | d   | L   | unit : mm                                  |
|-----------------|-----|-----|-----|--|
|                 |     |     |     | MAX Working Pressure (kg/cm <sup>2</sup> ) |
| FEMALE + FEMALE | 23  | N/A | 71  | 3  |
| FEMALE + MALE   | 23  | 6   | 71  | 3  |
| MALE + MALE     | N/A | 6   | 71  | 3  |
| FEMALE + HOSE   | 16  | 6   | 91  | 3  |
| MALE + HOSE     | 16  | 6   | 91  | 3  |
| HOSE + HOSE     | 16  | 6   | 111 | 3  |

