

GEMÜ 428

Motorized butterfly valve



Features

- Suitable for vacuum applications and low temperatures
- High-quality butterfly valve made from stainless steel or brass
- Available in small nominal sizes
- Compact and robust body

Description

The GEMÜ 428 soft seated butterfly valve made from stainless steel or brass is motorized. A manual override and an optical position indicator are integrated as standard. With its rounded and polished disc edges, the butterfly valve is optimized for frequent cycle duties. The surface of the butterfly valve can be further finished.

Technical specifications

- Media temperature: -20 to 120 °C
- Ambient temperature: -10 to 60 °C
- Operating pressure : 0 to 10 bar
- Nominal sizes: DN 15 to 50
- Connection types: Clamp | Spigot | Threaded connection
- Connection standards: ASME | DIN | EN | ISO | SMS
- Body materials: 1.4408, investment casting material | CW614N, brass | CW617N, brass
- Liner materials: EPDM | FKM | Silicone
- Disc materials: 1.4408, investment casting material | CW614N, brass | CW617N, brass
- Supply voltage: 100 - 120 V AC, 50/60 Hz | 12 - 24 V AC/DC | 220 - 240 V AC, 50/60 Hz | 380 - 480 V AC, 50/60 Hz
- Operating time 90°: 4 to 100 s
- Protection class: IP 65, 66, 67, 68
- Conformities: CSA | EAC | FDA

Technical data depends on the respective configuration



Product line



Operation

With bare shaft	●	-	-	-
Manual	-	●	-	-
Pneumatic	-	-	●	-
Motorized	-	-	-	●
Nominal sizes	DN 15 to 50	DN 15 to 50	DN 15 to 50	DN 15 to 50
Media temperature	-20 to 160 °C	-20 to 120 °C	-20 to 120 °C	-20 to 120 °C
Operating pressure	0 to 10 bar	0 to 10 bar	0 to 10 bar	0 to 10 bar
Connection types				
Clamp	●	●	●	●
Spigot	●	●	●	●
Threaded connection	●	●	●	●
Conformities				
ATEX	●	-	-	-
CSA	-	-	-	●
EAC	●	●	●	●
FDA	●	●	●	●

Motorized GEMÜ, Bernard actuators

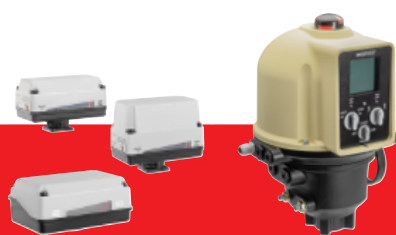

GEMÜ 9428

GEMÜ BC

Manufacturer	GEMÜ	Bernard Controls
Manufacturer type	9428	AQ, AQL
Torques	6 to 55 Nm	50 to 500 Nm
Duty cycle	100 % (12 V/24 V) 40 % (100 - 250 V)	30 % (ON/OFF actuator) 50 % (control actuator)
Heating	No	Yes
Voltage		
12 V DC	●	-
230 V AC, 50 Hz	●	●
230 V AC, 60 Hz	-	●
24 V DC	●	●
Protection class	IP 65	IP 68
Ambient temperature	-10 to 60 °C	-40 to 60 °C
Housing materials		
Aluminium	-	●
PP	●	-
Versions		
Limit switches	●	●
ON/OFF actuator	●	●
Optional on-site control	-	●
Optional positioning actuator	-	●
Optional potentiometer	-	●

Comparison of actuator areas of application

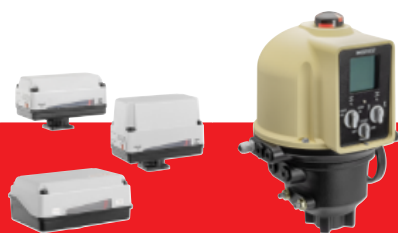

GEMÜ 9428

GEMÜ BC

Functional scope

Use in non-aggressive environment (up to C3)	●	●
Use in aggressive environment (C5)	●	●
Use in protected outdoor areas	●	●
Use in unprotected outdoor areas	●	●
Applications with many/frequent cycle duties	●	●
Fail-safe option	●	●
Positioning application	●	●
Industrial sectors		
Chemical processes	●	●
Surface finishing	●	●
Water treatment	●	●
Mechanical engineering	●	●
Power generation and environmental systems	●	●
Food processing technology	●	●
Semiconductor	●	●
Medical systems	●	●
Pharmaceutical industry	●	●

Product description

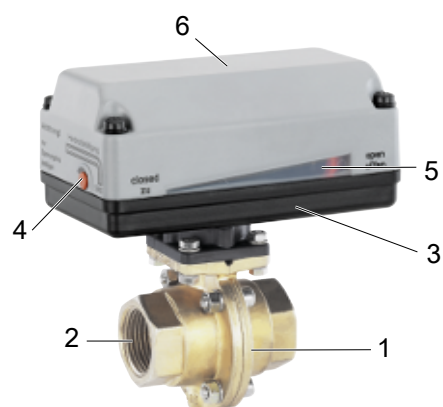

Item	Name	Material
1	Valve body	Brass (CW617N), investment casting (1.4408)
2	Pipe connections	Brass (CW617N), investment casting (1.4408)
3	Housing base	Actuator versions 1006, 1015, 2006, 2015: PP + 30 % glass fibre reinforced Actuator version 3035: PP + 20 % glass bead reinforced
4	Connection for manual override	
5	Optical position indicator	PP-R natural
6	Housing cover	Actuator versions 1006, 1015, 2006, 2015: PPE + 30 % glass fibre reinforced Actuator version 3035: PP + 20 % glass bead reinforced

Availability**Body**

DN	NPS	Body material code ¹⁾										
		Brass code 12		Investment casting code 37								
		Connection type code ²⁾										
		Threaded socket		Spigot							Clamp	
1	31	0	16	17	18	37	59	60	86	88		
15	1/2"	X	X	X	X	X	X	-	X	X	X	X
20	3/4"	X	X	X	X	X	X	-	X	X	X	X
25	1"	X	X	X	X	X	X	X	X	X	X	X
32	1 1/4"	X	X	X	X	X	X	X	-	X	X	-
40	1 1/2"	X	X	X	X	X	X	X	X	X	X	X
50	2"	X	X	X	X	X	X	X	X	X	X	X

1) **Body material**

Code 12: CW614N, CW617N (brass)

Code 37: 1.4408, investment casting

2) **Connection type**

Code 1: Threaded socket DIN ISO 228

Code 31: Threaded socket NPT

Code 0: Spigot DIN

Code 16: Spigot EN 10357 series B (formerly DIN 11850 series 1)

Code 17: Spigot EN 10357 series A (formerly DIN 11850 series 2)

Code 37: Spigot SMS 3008

Code 59: Spigot ASME BPE

Code 60: Spigot ISO 1127 / EN 10357 series C

Code 86: Clamp DIN 32676 series A, face-to-face dimension FTF EN 558 series 14

Code 88: Clamp ASME BPE, face-to-face dimension FTF EN 558 series 14

Actuator

GEMÜ 9428 actuator - Voltage/Frequency

Actuator version Code ¹⁾	Control module Code ²⁾	Voltage/Frequency				
		12 V DC (code B1)	12 V AC (code B4)	24 V DC (code C1)	24 V AC (code C4)	100-250 V AC (code O4)
1006	A0, AE	X	X	X	X	-
1015	A0, AE	X	-	X	-	-
3035	A0, AE	-	-	X	-	X

1) Actuator version

Code 1006: GEMÜ actuator, motorized, size 1, operating time 4 s, torque 6 Nm, supply voltage B1, C1, B4, C4

Code 1015: GEMÜ actuator, motorized, size 1, operating time 11 s, torque 15 Nm, supply voltage B1, C1

Code 3035: GEMÜ actuator, motorized, size 3, operating time 15 s, torque 35 Nm, supply voltage C1, O4

2) Control module

Code A0: On/Off actuator

Code AE: On/Off actuator with 2 additional, potential-free limit switches, Class A (EN15714-2)

GEMÜ 9428 actuator

DN	Actuator version ¹⁾		
	1006	1015	3035
15	X	X	-
20	X	X	-
25	X	X	-
32	-	X	X
40	-	-	X
50	-	-	X

1) Actuator version

Code 1006: GEMÜ actuator, motorized, size 1, operating time 4 s, torque 6 Nm, supply voltage B1, C1, B4, C4

Code 1015: GEMÜ actuator, motorized, size 1, operating time 11 s, torque 15 Nm, supply voltage B1, C1

Code 3035: GEMÜ actuator, motorized, size 3, operating time 15 s, torque 35 Nm, supply voltage C1, O4

Bernard actuator

DN	Actuator version ¹⁾	
	BC1L	BC3L
15	X	X
20	X	X
25	X	X
32	-	X
40	-	X
50	-	X

1) Actuator version

Code BC1L: BERNARD actuator, motorized, type AQ1L, operating time 13s, torque 15Nm, 2 additional limit switches, heating, manual override, aluminium housing, RAL5002, IP 67

Code BC3L: BERNARD actuator, motorized, type AQ30, operating time 15s, torque 30Nm, 2 additional limit switches, heating, manual override, aluminium housing, RAL5002, IP 67

Order data

Butterfly valve with GEMÜ 9428 actuator

The order data provide an overview of standard configurations.

Please check the availability before ordering. Other configurations available on request.

Order codes

1 Type	Code
Butterfly valve, motorized	428

2 DN	Code
DN 15	15
DN 20	20
DN 25	25
DN 32	32
DN 40	40
DN 50	50

3 Body configuration	Code
2/2-way body	D

4 Connection type	Code
Spigot	
Spigot DIN	0
Spigot EN 10357 series B (formerly DIN 11850 series 1)	16
Spigot EN 10357 series A (formerly DIN 11850 series 2)	17
Spigot SMS 3008	37
Spigot ASME BPE	59
Spigot ISO 1127 / EN 10357 series C	60
Threaded socket	
Threaded socket DIN ISO 228	1

5 Body material	Code
CW614N, CW617N (brass)	12
1.4408, investment casting	37

6 Liner	Code
FPM	4
Silicone (MVQ)	9
EPDM	14

7 Voltage/Frequency	Code
12 VDC	B1
12 V 50/60 Hz	B4
24 VDC	C1
24 V 50/60 Hz	C4
100-250V 50/60Hz	O4

8 Control module	Code
On/Off actuator	A0

8 Continuation of Control module	Code
On/Off actuator, 2 additional potential-free limit switches, Class A (EN15714-2)	AE

9 Actuator version	Code
GEMÜ actuator, motorized, size 1, operating time 4 s, torque 6 Nm, supply voltage B1, C1, B4, C4	1006
GEMÜ actuator, motorized, size 1, operating time 11 s, torque 15 Nm, supply voltage B1, C1	1015
GEMÜ actuator, motorized, size 3, operating time 15 s, torque 35 Nm, supply voltage C1, O4	3035

10 Type of design	Code
Standard	
Parallel operation of several actuators	6410
1 Hirschmann connector N6R	6598
2 Harting connectors Han 7D	6722

Order example

Order option	Code	Description
1 Type	428	Butterfly valve, motorized
2 DN	25	DN 25
3 Body configuration	D	2/2-way body
4 Connection type	1	Threaded socket DIN ISO 228
5 Body material	12	CW614N, CW617N (brass)
6 Liner	14	EPDM
7 Voltage/Frequency	C1	24 VDC
8 Control module	A0	On/Off actuator
9 Actuator version	1006	GEMÜ actuator, motorized, size 1, operating time 4 s, torque 6 Nm, supply voltage B1, C1, B4, C4
10 Type of design		Standard

Butterfly valve with Bernard actuator

The order data provide an overview of standard configurations.

Please check the availability before ordering. Other configurations available on request.

Order codes

1 Type	Code
Butterfly valve, motorized	428

2 DN	Code
DN 15	15
DN 20	20
DN 25	25
DN 32	32
DN 40	40
DN 50	50

3 Body configuration	Code
2/2-way body	D

4 Connection type	Code
Spigot	
Spigot DIN	0
Spigot EN 10357 series B (formerly DIN 11850 series 1)	16
Spigot EN 10357 series A (formerly DIN 11850 series 2)	17
Spigot SMS 3008	37
Spigot ASME BPE	59
Spigot ISO 1127 / EN 10357 series C	60
Threaded socket	
Threaded socket DIN ISO 228	1

5 Body material	Code
CW614N, CW617N (brass)	12
1.4408, investment casting	37

6 Liner	Code
FPM	4
Silicone (MVQ)	9
EPDM	14

7 Voltage/Frequency	Code
24VDC 85-260VAC	Y5

8 Control module	Code
On/Off actuator, 2 additional potential-free limit switches, Class A (EN15714-2)	AE
On/Off actuator, potentiometer output, Class A (EN15714-2)	AP
On/Off actuator, analogue position feedback 0/4-20mA, 2 additional potential-free limit switches	AT
Control actuator, external set value 0/4-20 mA	E2

9 Actuator version	Code
BERNARD actuator, motorized, type AQ1L, operating time 13s, torque 15Nm, 2 additional limit switches, heating, manual override, aluminium housing, RAL5002, IP 67	BC1L
BERNARD actuator, motorized, type AQ30, operating time 15s, torque 30Nm, 2 additional limit switches, heating, manual override, aluminium housing, RAL5002, IP 67	BC3L

10 Type of design	Code
Standard	
Parallel operation of several actuators	6410
1 Hirschmann connector N6R	6598
2 Harting connectors Han 7D	6722

Order example

Order option	Code	Description
1 Type	428	Butterfly valve, motorized
2 DN	25	DN 25
3 Body configuration	D	2/2-way body
4 Connection type	1	Threaded socket DIN ISO 228
5 Body material	12	CW614N, CW617N (brass)
6 Liner	14	EPDM
7 Voltage/Frequency	Y5	24VDC 85-260VAC
8 Control module	AE	On/Off actuator, 2 additional potential-free limit switches, Class A (EN15714-2)
9 Actuator version	BC1L	BERNARD actuator, motorized, type AQ1L, operating time 13s, torque 15Nm, 2 additional limit switches, heating, manual override, aluminium housing, RAL5002, IP 67
10 Type of design		Standard

Butterfly valve technical data

Medium

Working medium: Corrosive, inert, gaseous and liquid media which have no negative impact on the physical and chemical properties of the body, disc and seal material. The product is only suitable for use with fluids of group 2 according to the Pressure Equipment Directive.

Temperature

Media temperature:

Liner material

FPM (Code 4)

PSI (Code 9)

EPDM (Code 14)

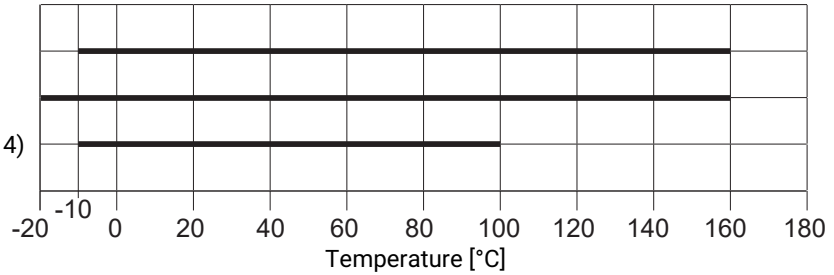

For media temperatures above 100 °C additionally use mounting kit GEMÜ MSC (see accessories).

Ambient temperature: -10 to 60 °C

Storage temperature: -20 to 60 °C

Pressure

Operating pressure: 0 to 10 bar

Pressure rating: PN 10

Kv values:

DN	Threaded socket	Butt weld spigot
	Body material ¹⁾	
	Code 12	Code 37
15	7	7
20	12	15
25	17	20
32	40	55
40	60	90
50	100	140

Kv values in m³/h

1) **Body material**

Code 12: CW614N, CW617N (brass)

Code 38: 1.4581, investment casting

Product compliance

Machinery Directive:	2006/42/EC
Pressure Equipment Directive:	2014/68/EU
EMC Directive:	2014/30/EU
Low Voltage Directive:	2014/35/EU
Approvals:	FDA

Mechanical data

Protection class: IP 65 acc. to EN 60529

Operating time:

Actuator version 1006:	4
Actuator version 1015:	11
Actuator version 3035:	15

Operating times in s

Torques:

Actuator version 1006: 6 Nm
 Actuator version 1015: 15 Nm
 Actuator version 3035: 35 Nm
 Actuator version 3055: 55 Nm

Nominal travel:

90°

Max. travel:

93°

Setting range:

0 to 20° (limit switch Min.)
 70 to 93° (limit switch Max.)

Weight:

Body

DN	Body material ¹⁾	
	Code 12	Code 37
15	670	900
20	750	940
25	910	1020
32	930	1100
40	1410	1500
50	2020	1950

Weight in g

1) **Body material**

Code 12: CW614N, CW617N (brass)

Code 37: 1.4408, investment casting

Technical data of actuator

GEMÜ 9428 actuators

Mechanical data

Weight: GEMÜ 9428

Supply voltage 12 V / 24 V:	1.0 kg
Supply voltage 100-250 V:	1.2 kg
Supply voltage 24 V / 100-250 V	2.4 kg
Actuator version 3035:	2.4 kg

Electrical data

Duty cycle: Supply voltage 12 V / 24 V: Continuous duty
Supply voltage 100 - 250 V: 40 % duty

Electrical protection: Supply voltage 12 V / 24 V:
Motor protective system by customer
Supply voltage 100 - 250 V:
Integrated stall and overload protection
plus excess current release T 1A 5x20 mm

Electrical protection class: I (DIN EN 61140)

Electrical connection

Electrical connection type: Supply voltage 12 V / 24 V: Cable gland PG 13.5
Supply voltage 100 - 250 V: Hirschmann plug Type N6RFFS11 (PG 11)

Cable diameter: Supply voltage 12 V / 24 V: 7.5 to 12.5 mm
Supply voltage 100 - 250 V: 7.0 to 9.0 mm

Max. cross section of wire: 1.5 mm²

Recommended motor protection:

Voltage	12 V DC	24 V DC	120 V AC	230 V AC
Motor protection switch type	Siemens 3RV 1011-1CA10	Siemens 3RV 1011-1BA10	Siemens 3RV 1011-OGA10	Siemens 3RV 1011-OGA10
Set current	2.20	1.70	0.60	0.45

Current data in A

Rated voltage: 12 V / 24 V AC or DC ($\pm 10\%$)
100 – 250 V AC ($\pm 10\%$)

Rated frequency: 50/60 Hz (at AC rated voltage)

Power consumption:

Actuator version	12 V DC	12 V AC	24 V DC	24 V AC	100-250 V AC
	Code B1	Code B4	Code C1	Code C4	Code O4
1006	30	30	30	30	-
1015	30	-	30	-	-
2006	-	-	-	-	60
2015	-	30	-	30	50
3035	-	-	30	-	50
3055	-	-	30	-	50

Power consumption in W

Current consumption:

Actuator version	12 V DC	12 V AC	24 V DC	24 V AC	100-250 V AC
	Code B1	Code B4	Code C1	Code C4	Code O4
1006	2.2	2	1.2	1.5	-
1015	2.2	-	1.2	-	-
2006	-	-	-	-	0.25
2015	-	2	-	1.2	0.2
3035	-	-	1.3	-	0.2
3055	-	-	1,3	-	0,2

Current data in A

Max. current at start up:

Actuator version	12 V DC	12 V AC	24 V DC	24 V AC	100-250 V AC
	Code B1	Code B4	Code C1	Code C4	Code O4
1006	6.3	2.4	4.0	1.8	-
1015	9.2	-	3.8	-	-
2006	-	-	-	-	0.3
2015	-	2.3	-	1.8	0.4
3035	-	-	3.3	-	0.2
3055	-	-	3,3	-	0,2

Current data in A

Bernard actuators

Note: For technical data see manufacturer's original datasheets

Dimensions

Mounting height

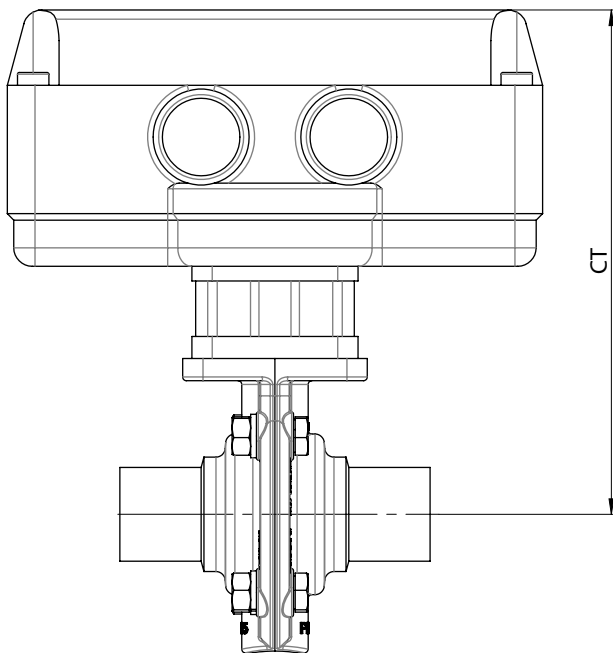

DN	CT		
	Actuator version		
	1006, 1015	3035 (24V)	3035 (100-250V)
15	135.5	-	-
20	135.5	-	-
25	135.5	-	-
32	142	148.5	172.5
40	-	156.5	180.5
50	-	165.5	189.5

Dimensions in mm

Actuator

Actuator version 1006, 1015

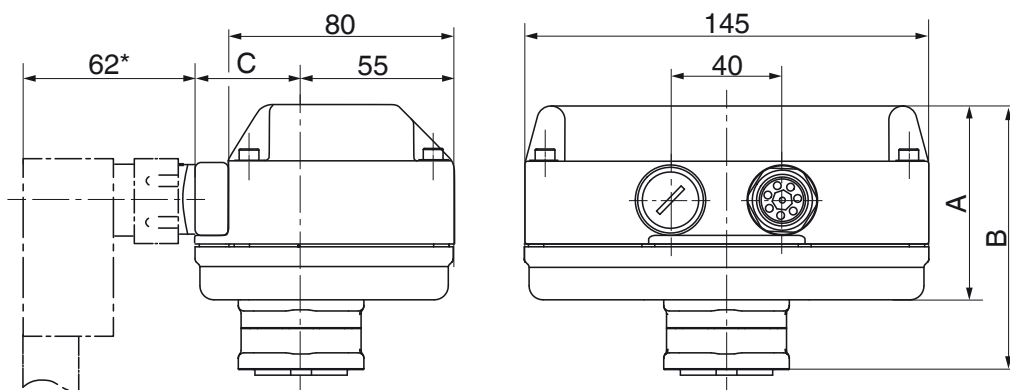

* Standard with supply voltage code O4

Actuator version	A	B	C
1006, 1015	69	94	49

Dimensions in mm

Actuator version 3035

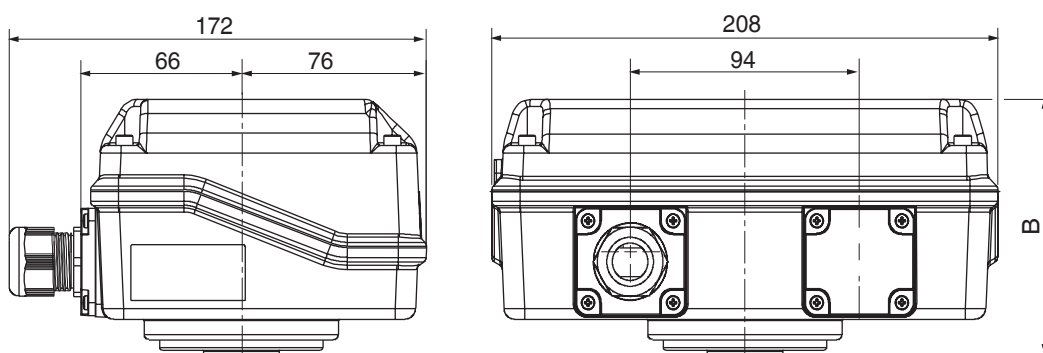

Voltages	B
24 V	100.5
100 V - 250 V	124.5

Dimensions in mm

Connection dimensions actuator version (10XX, 20XX, 30XX)

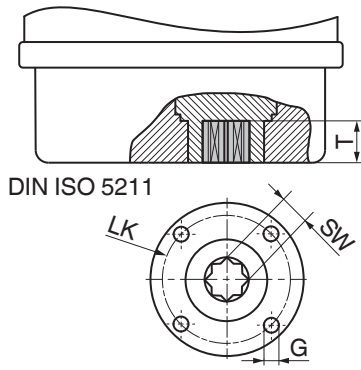

DIN ISO 5211

Actuator version (code)	Connection size (code)	Location spigot (code)	SW	G	LK	T
10XX / 20XX	G05	Y	S08	Ø5.5	48	15
10XX / 20XX	F03	N	S09	M5	36	16
10XX / 20XX	F04	N	S09	M5	42	16
10XX / 20XX	F05	N	S09	M6	50	16
10XX / 20XX	F05	N	S11	M6	50	16
30XX	F05	Y	S14	M6	50	22

Dimensions in mm

Third-party actuators

For more detailed information on third-party actuators, refer to the manufacturers' documentation

Body

Butt weld spigot (connection type code 0, 16, 17, 37, 59, 60)

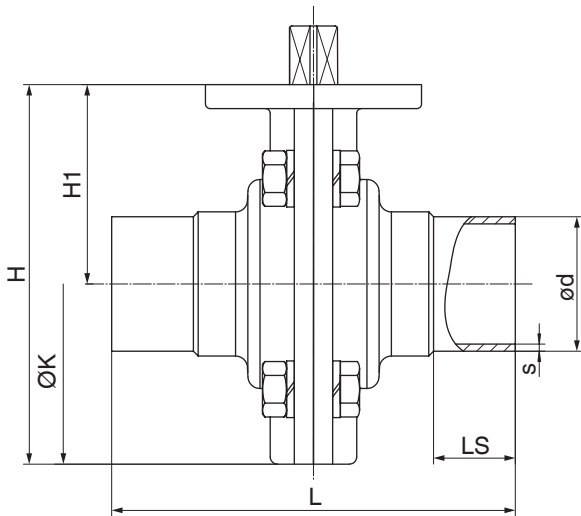

DN	NPS	L	H	H1	øK	LS	DIN		EN 10357			
							Code 0		Code 16		Code 17	
							ød	s	ød	s	ød	s
15	1/2"	80	79	41.5	75	20	18	1.5	18	1	19	1.5
20	3/4"	84	79	41.5	75	22	22	1.5	22	1	23	1.5
25	1"	84	79	41.5	75	22	28	1.5	28	1	29	1.5
32	1¼"	88	91	48.0	85	25	34	1.5	34	1	35	1.5
40	1½"	96	108	56.0	103	25	40	1.5	40	1	41	1.5
50	2"	110	123	65.0	116	30	52	1.5	52	1	53	1.5

DN	NPS	L	H	H1	øK	LS	SMS 3008		EN ISO 1127		ASME BPE	
							Code 37		Code 60		Code 59	
							ød	s	ød	s	ød	s
15	1/2"	80	79	41.5	75	20	-	-	21.3	1.6	12.7	1.65
20	3/4"	84	79	41.5	75	22	-	-	26.9	1.6	19.1	1.65
25	1"	84	79	41.5	75	22	25.0	1.2	33.7	2.0	25.4	1.65
32	1¼"	88	91	48.0	85	25	33.7	1.2	42.4	2.0	-	-
40	1½"	96	108	56.0	103	25	38.0	1.2	48.3	2.0	38.1	1.65
50	2"	110	123	65.0	116	30	51.0	1.2	60.3	2.0	50.8	1.65

Dimensions in mm

Threaded socket (connection type code 1, 31)

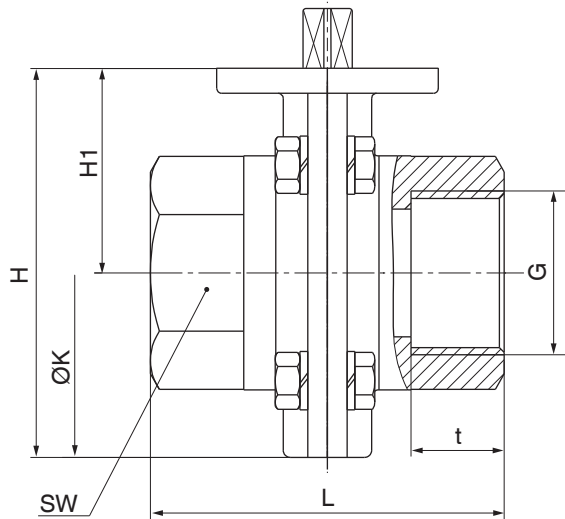

DN	G	L	H	H1	t	øK	SW	n
15	1/2"	72	79	41.5	15.0	75	27	6
20	3/4"	72	79	41.5	16.0	75	32	6
25	1"	72	79	41.5	19.0	75	41	6
32	1¼"	72	91	48.0	21.4	85	50	8
40	1½"	83	108	56.0	21.4	103	55	8
50	2"	88	123	65.0	25.7	116	70	8

Dimensions in mm
n = number of flats

Clamp (connection type code 86, 88)

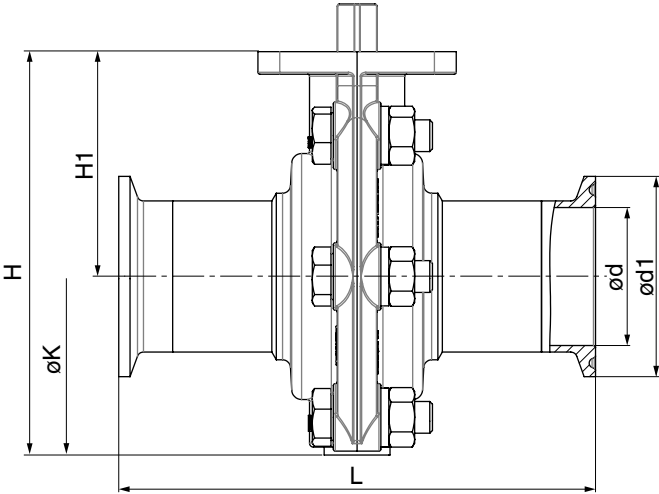

DN	NPS	L	H	H1	øK	DIN 32676 series A		ASME BPE	
						Code 86		Code 88	
						ød	ød1	ød	ød1
15	1/2"	115	79	41.5	75	16	34.0	9.4	25.0
20	3/4"	120	79	41.5	75	20	34.0	15.8	25.0
25	1"	125	79	41.5	75	26	50.5	22.1	50.5
32	1¼"	130	91	48.0	85	32	50.5	-	-
40	1½"	140	108	56.0	103	38	50.5	34.8	50.5
50	2"	150	123	65.0	116	50	50.5	47.5	64.0

Dimensions in mm

Accessories



GEMÜ MSC

Mounting kit

GEMÜ MSC is an open mounting kit for the adaptation of quarter turn actuators. The mounting kits include different parts depending on the butterfly valve actuator configuration. Fastening screws are not included.



GEMÜ Gebr. Müller Apparatebau GmbH & Co. KG
Fritz-Müller-Straße 6-8, 74653 Ingelfingen-Criesbach, Germany
Phone +49 (0)7940 123-0 · info@gemu.de
www.gemu-group.com