



Take
a Good Look
It May Be Your Future



MARS

SERIES 99

Direct Mount
High Performance
Compact Ball Valves 1/2" to 6" Full Port
PN10-40, ANSI #150

www.marsvalve.com.tw



DO YOU STILL USE CONVENTIONAL ACTUATOR MOUNTING?

Conventional mounting method is to use a bracket and adapter between ball valve and actuator, however, the bracket and adapter can often be the source of failure for valve / actuator packages:

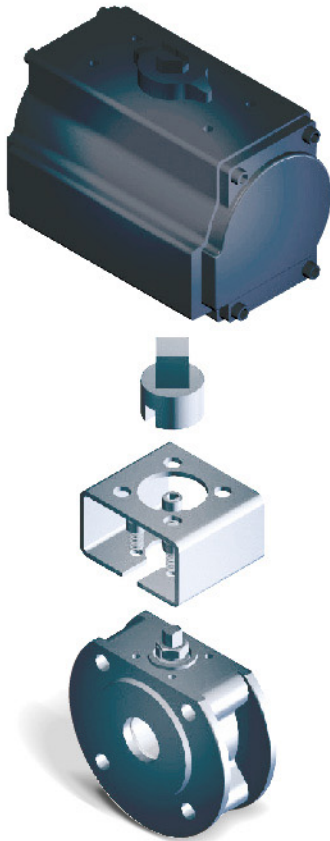

- A simple misalignment of the bracket and adapter can cause excessive wear and high torque than expected, this can result in stem leakage or valve stall.
- A warped bracket, however slightly, or the bolt drillings lose center, stem side loading can occur.
- If the adapter is too long and bracket bolts are drawn down tightly, the adapter can jam the valve stem into valve ball resulting in higher torque than the actuator provided.
- The bracket and adapter leave exposed moving parts, when the adapter turns it can become a pinch point and injury may occur.
- The connections between the adapter and the valve stem and the adapter and the actuator drive can create a slope, known as hysteresis, the looseness of the connecting surface can cause the valve to not fully open or fully close.

Patented Direct Mount Design

The U.S., Germany, and China Patent and Trademark Offices Have awarded Mars Valve Patent Protection for the Direct Mount Design.



- 1) U.S. Patent 5,954,088
- 2) Germany Patent 299.02.532.2
- 3) China Patent ZL 98 2 09161.3

Mars Direct Mount Ball Valve Sets A New Standard For Ball Valve / Actuator Mounting, Enhances Functional Performance With Easy Installation And Lower Maintenance Cost.



The new way of mounting actuator is the Direct Mount Configuration, it is designed to overcome the problems of conventional actuator mounting. This design allows an actuator bolted directly to the top of ball valves for greater reliability, easy installation and improved cycling life.

No bracket and adapter are required, the valve stem is an integral part of the actuator drive. The direct valve stem coupling to actuator shaft ensures correct alignment of the valve to the actuator, minimizes stem side loading and backlash during operation, increased service life and performance.



●Modular design and simplicity

No confusion as to how to select brackets and adapters.

●Low cost and easy automation

Direct mount eliminates the need for additional brackets and adapters, time and labor saving too.

In the event maintenance is needed, Mars Direct Mount ball valves facilitate fast, easy breakdown and assembly of ball valve and actuator package, the result is reduced maintenance time and the lowest overall cost of ownership.

●Compact and Space-Saving

The close coupling of the actuator to the valve makes the total package as compact as possible.

●Safety

There are no External Moving Parts, No Pinch Points.

●Direct Valve Stem / Actuator Drive Connection

Less chance for Hysteresis.

SERIES 99

Direct Mount High Performance Compact Ball Valves

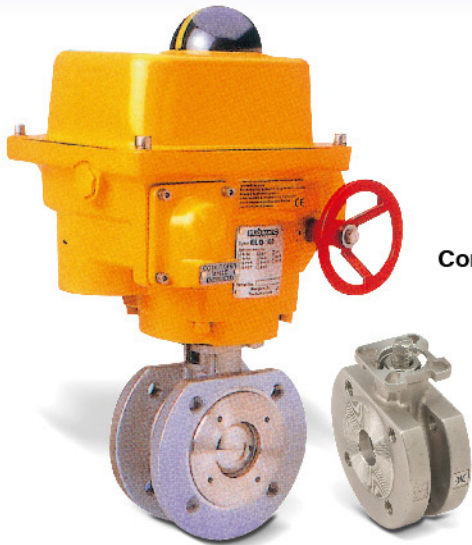

Mars Patented Direct Mount Ball Valves
Making Automation Easy

- Construction** One-Piece Investment Cast Construction, Full Port
Size Range 1/2" to 6" (DN 15 to DN 150)
Pressure Rating PN10-40, ANSI CLASS 150
Valve Material Standard: ASTM A351 Gr. CF8M / EN 10213 1.4408
 Options: WCB/1.0619, CF3M/1.4409, Titanium, Duplex S/S, Hastelloy C....etc.
Seat Material Standard: R-TFE
 Options: TFM 1600, PEEK, Carbon filled PTFE, Delrin, UHMWPE, 50/50 S/S filled PTFE, Metal Seats....and others

- Inspection and Test** API 598
Compliance Standards ASME B16.34, EN 1092-1, ASME B16.5, ISO 5211, MSS SP-55, ISO 5209

- Material Certificate** EN 10204 - 3.1
Quality System ISO 9001

NACE MR - 0175 The rugged, high performance Series 99 ball valves meet requirement for oil and gas pipeline service and meet NACE specification MR - 0175 for sour gas.

APPROVALS



TA-Luft



ATEX 2014/34/EU



SIL 3

Mars Unique SealMax® Triple - Sealing Stem Packing System - Live Loaded Maintenance Free - Extra Long Cycle Life - TA-Luft Approved

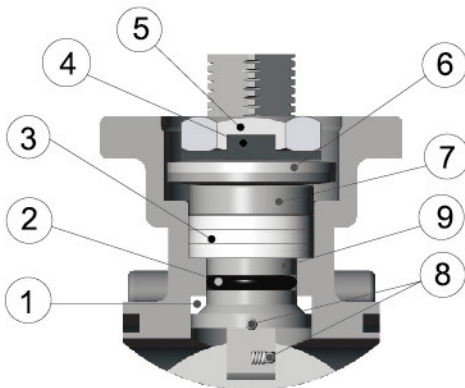

- 1. Pyramidal Stem with Stem Seal**
First stage of defense against leakage. The 45° slope of the stem accompany the stem seal effectively blocks all leak path during rotation.
- 2. O-Ring Stem Packing**
Second stage of defense against leakage. Enhances stem seal and maintains stem alignment, provides extra longer service life
- 3. V-Ring Stem Packing**
Third stage of defense against leakage. Multiple layers of V-Ring Chevron Packing expands side way as it is being compressed, blocking all air pockets to prevent leak path.
- 4. Lock Saddle**
Stabilizes the entire stem nut to keep it from loosening during operation
- 5. Stem Nut**
Compress the entire stem system to enable blocking of leakage.
- 6. Belleville Washers**
Automatically compress the seals to adjust for wear, pressure, and temperature fluctuations.
- 7. Gland**
Made of stainless steel, equally distributes the compressive force on the packing and seal.
- 8. Anti-Static Device**
Stem-to-Ball and Stem-to-Body as standard.
- 9. Super Smooth Stem Finish**
Reduces seal friction and operating torque, prolongs service life.

MATERIALS LIST

NO.	PART NAME	MATERIAL	Q'TY
1	Body	1.4408/CF8M/WCB/1.0619	1
2	End Cap	1.4408/CF8M/WCB/1.0619	1
3	Ball	1.4408/CF8M	1
4	Seat	PTFE/RPTFE	2
5	Joint Gasket	PTFE	1
6	Joint Gasket	PTFE	1
7	Stem Seal	RPTFE	1
8	Stem	SUS 316	1
9	Stem Packing	PTFE	*
10	Stem Packing	25% Glass Fiber Filled + PTFE	1
11	Gland	SUS 304	1
12	Belleville Washer	SUS 301	2
13	Lock Saddle	SUS 304	1
14	Stem Nut	SUS 304	2
15	Stem Washer	SUS 304	1
16	Handle	SUS 304	1
17	Locking Device	SUS 304	1
18	Handle Sleeve	VINYL	1
19	Stop Pin	SUS 304	1
20	Pin Nut & Washer	SUS 304	1
21	Antistatic - Device	SUS 316	2
22	O-Ring	VITON	1

* For 1/2"-2"-2pcs, For 2 1/2"-6"-3pcs.

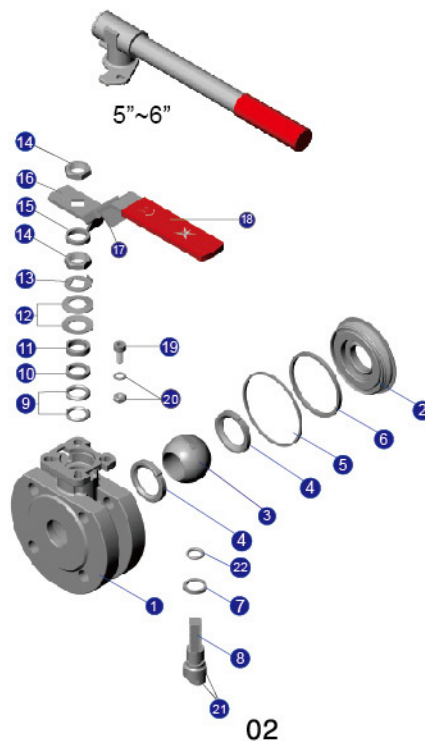

Direct Mount Compact Ball Valves Offer Advantage Well Beyond Followers



- 1. Dual Pattern ISO 5211 Mounting Pad With Square Shaft**
No bracket and adapter are required for actuator mounting, provides easy and low cost automation with improved cycle life.
- 2. MARS SealMax® Stem Design**
Provides optimum stem seal and extremely high cycle life.
- 3. Patented Leak-Watching Window**
Standard on Mars Direct Mount Ball Valves, for an early warning of stem leak, prevents accident and business disruption costs.

DIMENSIONS(mm)

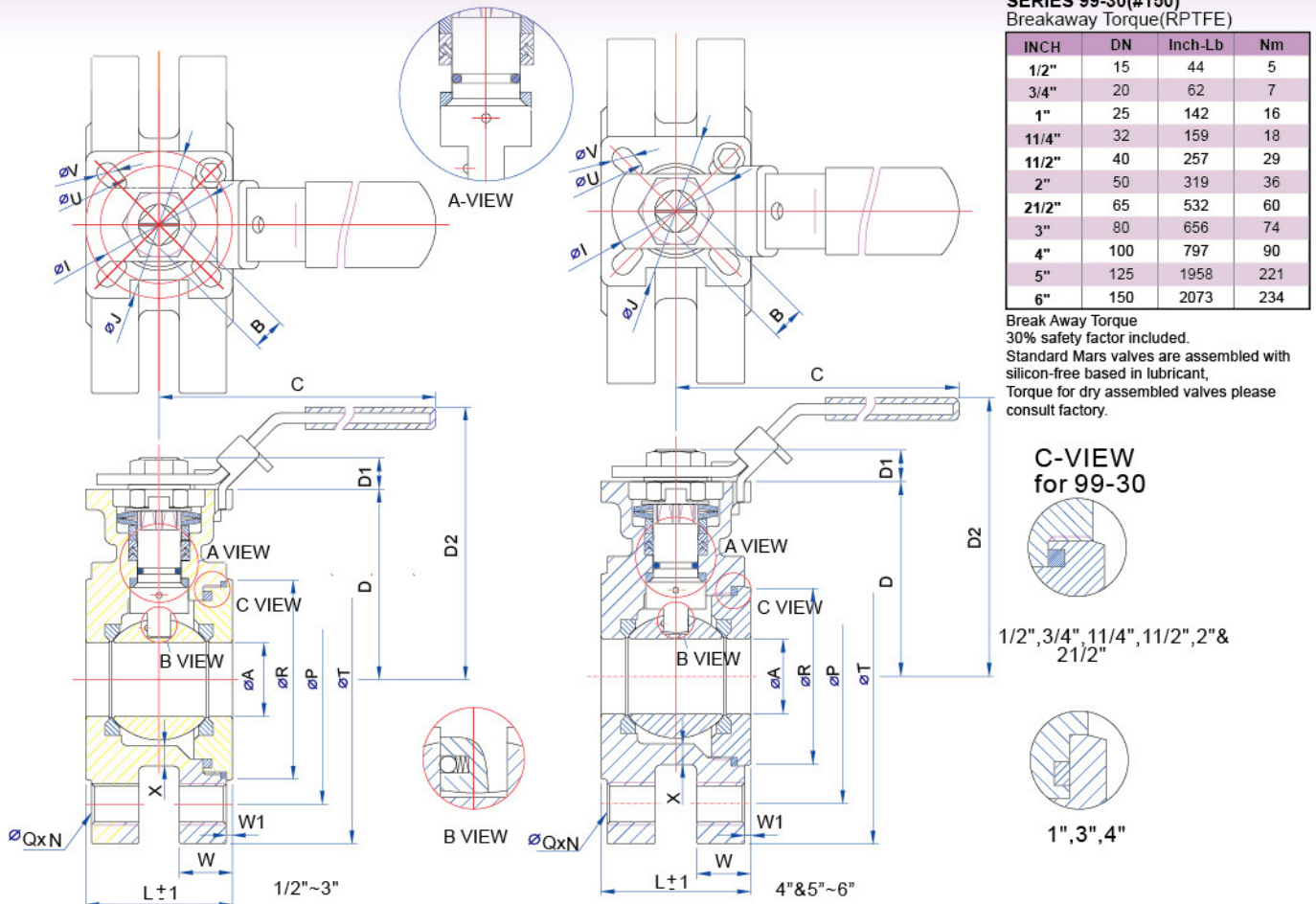

FIG. 99-10 (PN10/16) & FIG. 99-20(PN25/40)

Dimension B: 17/19 Standard 17, Option 19

* Dimension For 99-20

SIZE	øA	B	C	D	D1	D2	øI	øJ	L	N	øP	øQ	øR	øT	W	W1	øU	øV	Wt.(kg)	ISO5211	
1/2"	15.0	9	139	48.7	7	85	36	42	40.8	4	4	65	M12	45	82	16	2	6	6	1.30	F03/F04
3/4"	20.0	9	139	53.7	8	90	36	42	44	4	4	75	M12	58	98.6	18	2	6	6	1.96	F03/F04
1"	25.0	11	165	65	12	104	40	50	50	4	4	85	M12	68	115	18	2	6	7	2.8	F04/F05
1 1/4"	32.0	11	165	77	11.3	116	40	50	60	4	4	100	M16	78	140	18	2	6	7	4.15	F04/F05
1 1/2"	38.0	14	215	85.5	15.5	135	50	70	65	4	4	110	M16	88	150	18	3	7.5	9	5.25	F05/F07
2"	50.0	14	215	93	16	142	50	70	80	4	4	125	M16	102	165	20	3	7.5	9	6.66	F05/F07
2 1/2"	65.0	17	263	109.7	15.8	168	70	102	110	4	8	145	M16	122	185	22	3	10	12	11.88	F07/F10
3"	80.0	17	313	119.5	16	178	70	102	120	8	8	160	M16	138	200	24	3	10	12	14.9	F07/F10

FIG. 99-10 (PN10/16) & FIG. 99-20(PN25/40)

* Dimension For 99-20

SIZE	øA	B	C	D	D1	D2	D2	øI	øJ	L	N	øP	øQ	øR	øT	øT	W	W1	øU	øV	Wt.(kg)	ISO5211		
4"	100	17	344	131.7	132.7	17.8	190	191	70	102	150	8	180	190	162	220	235	20	24	3	10	12	20.38	F07/F10
5"	125	27	705	192.7	28.5	285	125	140	200	8	210	160	188	250	285	20.9	20.9	3	14	18	50.8	F12/F14		
6"	150	27	705	210.2	28.5	285	125	140	240	8	240	160	212	285	285	22.4	22.4	3	14	18	68.2	F12/F14		

99-30 (ANSI CLASS 150)

Dimension B: 17/19

Standard 17, Option 19

SIZE	øA	B	C	D	D1	D2	øI	øJ	L	N	øP	øQ	øR	øT	W	W1	øU	øV	X	Wt.(kg)	ISO5211
1/2"	15.0	9	139	48.7	7	85	36	42	40.8	4	60.5	1/2"-13UNC	35.1	88.9	11.2	1.6	6	6	7.7	1.69	F03/F04
3/4"	20.0	9	139	53.7	8	90	36	42	44	4	69.9	1/2"-13UNC	42.9	98.6	11.2	1.6	6	6	9	2.10	F03/F04
1"	25.0	11	165	65	12	104	40	50	50	4	79.2	1/2"-13UNC	64	108	11.2	1.6	6	7	7	3.02	F04/F05
1 1/4"	32.0	11	165	77	11.3	116	40	50	60	4	88.9	1/2"-13UNC	63.5	117.3	12.7	1.6	6	7	7	5.56	F04/F05
1 1/2"	38.0	14	215	85.5	15.5	135	50	70	65	4	98.6	1/2"-13UNC	73.2	127	14.3	1.6	7.5	9	6	6.17	F05/F07
2"	50.0	14	215	93	16	142	50	70	80	4	120.7	5/8"-11UNC	91.9	152.4	15.9	1.6	7.5	9	6	8.70	F05/F07
2 1/2"	65.0	17	263	109.7	15.8	168	70	102	110	4	139.7	5/8"-11UNC	104.6	177.8	17.6	1.6	10	12	8	13.62	F07/F10
3"	80.0	17	313	119.5	16	178	70	102	120	4	152.4	5/8"-11UNC	127	190.5	19	1.6	10	12	9	18.58	F07/F10
4"	100	17	344	132.7	17.8	191	70	102	150	8	190.5	5/8"-11UNC	157.2	228.6	23.9	1.6	10	12	9.2	29.6	F07/F10
5"	125	27	705	192.7	28.5	285	125	140	200	8	215.9	3/4"-10UNC	185.7	250	22.3	1.6	14	18	12	50.8	F12/F14
6"	150	27	705	210.2	28.5	285	125	140	240	8	241.3	3/4"-10UNC	215.9	285	23.8	1.6	14	18	12	68.2	F12/F14

4. Blow-Out Proof Stem

5. O-Ring Stem Seal

Enhances stem wear and maintains stem alignment

6. Super smooth stem surface

Reduces seal friction and operating torque

7. Locking Device Standard

8. Anti-Static Device

Standard applied to stem-to-ball and stem-to-body

9. Fully Encapsulated Body Seals

Maintains sealing integrity from high vacuum to high pressure and temperature applications.

10. Compact design for space and weight savings

11. Seats

- Features with relief slots to relieve pressure in upstream, reduces seat wear and valve torque
- Wide range of materials available to suit various applications

12. Ball

- Precisely machined, mirror finished ball surface for bubble tight shutoff with less operating torque
- A relief hole in stem slot to balance the pressure in the body cavity ensures tight shutoff and long service life
- V-PORT control valves available

13. Fire-safe design in compliance with API 607



MARS OPTIONAL VALVE ACCESSORIES INCREASE PRODUCTIVITY AND GIVE YOU MORE CONTROL OVER YOUR INDUSTRIAL PROCESS

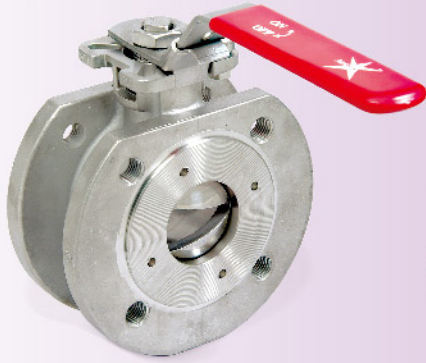

V-Control Ball Valves

Mars V-Control Ball valves match the control performance of globe valve, excellent for modulating service, but Mars V-Control ball valves are more compact, lighter weight, and much less expensive than globe valves.



30°V 60°V 90°V

30°V, 60°V, & 90°V are standard, others on request



Titanium Ball Valves

Light Weight, Excellent for Corrosion Resistance

Other special alloy available on request

Monel, Hastelloy C, Alloy 20, Duplex

Heating Jacket



Mars "TSM" unit

Adds Extra Safety and Long Service Life
TSM Design Advantages:

- The TSM unit designed for possible fugitive emission to meet TA-Luft requirements for a safe and clean environment, and provides a secondary stem seal for the valve stem, prolongs service life.
- Function as stem extension for insulation.
- Cast bosses for monitoring device



(SRS) Spring Return Safety Handle

The SRS Handle is a spring energized handle, the ball valve will return to pre-determined closed (or open) position when an operator disengages from handle, provides safe and positive fail close or open operation, creating a reliable sampling, filling, dispensing, and pressure relief valve.

Full S.S. construction provides excellent corrosion resistance for extended service life.



Spring Return Sliding Lock (SRSL) Handle

No matter the orientation of the ball valves, the SRSL handle always secures handle in position, making valve operation safe.

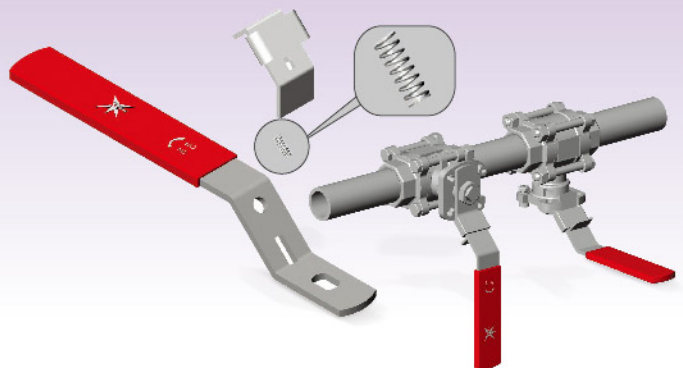

MARS VALVE OFFERS SINGLE-RELIABLE-SOURCE FOR A COMPLETE LINE OF BALL VALVES, ACTUATORS, AND ACCESSORIES TO MEET YOUR VALVE AUTOMATION REQUIREMENTS.

AirMars Pneumatic Actuators



Double-Acting (80 PSI)

Valve Size	A	B	C	D	E	F	H	Actuator	Lbs.	Wt	Kg.
1/2"	40.8	120	132.7	62.2	48.7	40.4	89.1	A-125	4.85	2.2	
3/4"	44	120	137.7	62.2	53.7	49.3	103	A-125	6.31	2.86	
1"	50	144.3	164	81.4	65	56.0	121	A-250	9.27	4.20	
1 1/4"	60	144.3	176	81.4	77	68.0	145	A-250	12.24	5.55	
1 1/2"	65	149.2	203.5	95	85.5	73.5	159	A-450	15.58	7.06	
2"	80	149.2	211	95	93	80.5	173.5	A-450	18.69	8.47	
2 1/2"	110	183	250.7	119	109.7	90.5	200.2	A-1000	32.87	14.90	
3"	120	183	260.5	119	119.5	95	214.5	A-1000	39.40	17.86	
4"	150	183	272.7	119	131.7	104	235.7	A-1000	51.21	23.21	
5"	200	304.3	388.7	185.2	192.7	125	317.7	A-3650	145.0	65.8	
6"	240	304.3	406.2	185.2	210.2	142.5	352.7	A-3650	183.4	83.2	

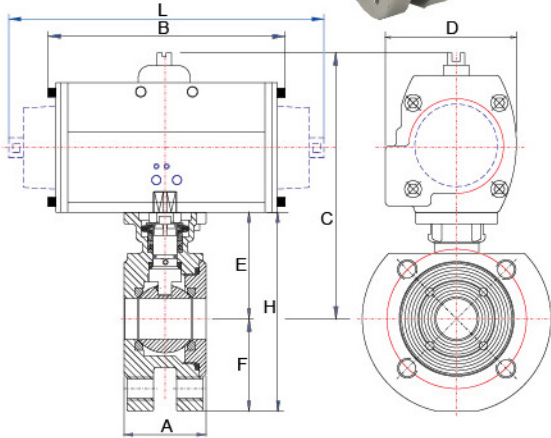

Spring-Return(80 PSI)

Valve Size	A	L	C	D	E	F	H	Actuator	Wt		Remark
									Lbs.	Kg.	
1/2"	40.8	194.6	147.7	81.4	48.7	40.4	89.1	A-250SR4	6.84	3.10	+□ ISO F04
3/4"	44	194.6	152.7	81.4	53.7	49.3	103	A-250SR4	8.30	3.76	+□ ISO F04
1"	50	205.6	183	95	65	56.0	121	A-450SR4	12.13	5.50	+□
1 1/4"	60	250.0	218	119	77	68.0	145	A-1000SR4	20.16	9.15	+□
1 1/2"	65	250.0	226.5	119	85.5	73.5	159	A-1000SR4	22.20	10.06	+□
2"	80	250.0	234	119	93	80.5	173.5	A-1000SR4	25.31	11.47	+□
2 1/2"	110	355.0	270.7	140.5	109.7	90.5	200.2	A-2250SR4	46.77	21.20	+□
3"	120	355.0	280.5	140.5	119.5	95	214.5	A-2250SR4	53.30	24.16	+□
4"	150	422.0	327.7	185.2	131.7	104	235.7	A-3650SR4	82.67	37.51	+□
5"	200	642.0	456.4	238.2	192.7	125	317.7	A-11000SR4	222.2	100.8	+□
6"	240	642.0	473.9	238.2	210.2	142.5	352.7	A-11000SR4	260.5	118.2	+□

PowerMars Electric Actuators

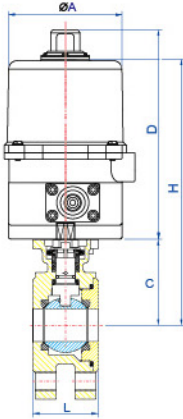

SIZE	Electric Actuator	Flange Type	◇	øA	C	D	H	L	◇STEM	ISO 5211	Lbs.	Kg	
1/2"	OM-1	F03/F05	14	106	48.7	150	198.7	40.8	9	F03/F04	7.06	3.2	+□
3/4"	OM-1	F03/F05	14	106	53.7	150	203.7	44	9	F03/F04	8.52	3.86	+□
1"	OM-1	F03/F05	14	106	65	150	215	50	11	F04/F05	10.15	4.6	+□
1 1/4"	OM-1	F03/F05	14	106	77	150	227	60	11	F04/F05	13.13	5.95	+□
1 1/2"	OM-1	F03/F05	14	106	85.5	150	235.5	65	14	F05/F07	15.14	6.86	+□
2"	OM-A	F05/F07	17	106	93	196	289	80	14	F05/F07	20.45	9.27	+□
2 1/2"	OM-2	F07	22	181	109.7	255	364.7	110	17	F07/F10	48.98	22.2	+□
3"	OM-2	F07	22	181	119.5	255	374.5	120	17	F07/F10	55.51	25.16	+□
4"	OM-3	F07	22	181	131.7	255	386.7	150	17	F07/F10	67.31	30.51	+□
5"	OM-4	F10	35	217	192.7	317	509.7	200	27	F12/F14	&	&	
6"	OM-4	F10	35	217	210.2	317	527.2	240	27	F12/F14	&	&	

& Mounting kit required.

DIMENSION(mm)

Dimension B:17/19 Standard 17, Option 19

SIZE	B	D1	ØI	ØJ	ØU	ØV	ISO5211
1/2"	9	7	36	42	6	6	F03/F04
3/4"	9	8	36	42	6	6	F03/F04
1"	11	12	40	50	6	7	F04/F05
1 1/4"	11	11.3	40	50	6	7	F04/F05
1 1/2"	14	15.5	50	70	7.5	9	F05/F07
2"	14	16	50	70	7.5	9	F05/F07
2 1/2"	17	19	50	102	10	12	F07/F10
3"	17	19	50	102	10	12	F07/F10
4"	17	19	70	102	10	12	F07/F10
5"	27	28.5	125	140	14	18	F12/F14
6"	27	28.5	125	140	14	18	F12/F14

99-10: 1/2"-6" 99-20: 1/2"-4" 99-30: 1/2"-6"

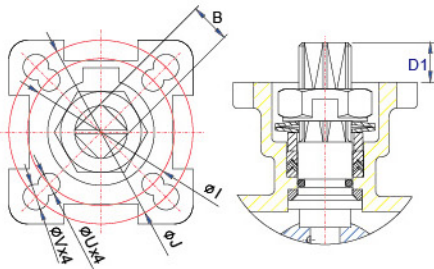

SERIES 99-10/20(PN16/40) SERIES 99-30(#150)

Pressure Vs. Temperature Chart

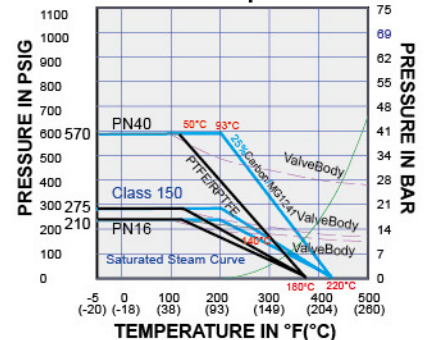

MARS VALVE CO., LTD.
 TRANSWORLD STEEL ENT.CO., LTD.
 NO.83, SEC.1, CHUNG-DE 8th ROAD,
 TAICHUNG. 406, TAIWAN R.O.C.
 TEL:++886-4-2246 3808
 FAX:++886-4-2247 0912
 E-mail: mars@marsvalve.com.tw
 http://www.marsvalve.com.tw

Distributed by: