



# SERIES 10 & 20

## MADE IN MARS

**Economical  
One-Piece / Two-Piece Ball Valves  
Stainless Steel And Carbon Steel  
Threaded Ends  
1000 / 1500 / 2000 PSI**

### SERIES 10-10

Reduced Port

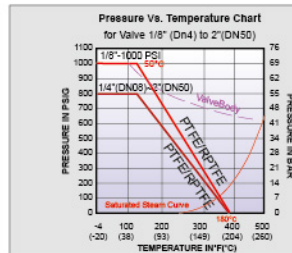
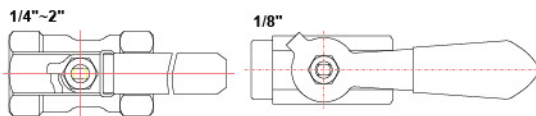
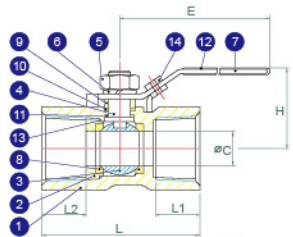

#### DIMENSIONS (mm)

SIZE	øC	E	H	L	L1	L2	WL(Kg)
1/8"	5.0	60	30.5	39.5	10.0	9.0	0.01
1/4"	5.0	64	35	39	11.0	7.0	0.07
3/8"	7.0	70	37	44	11.0	8.0	0.11
1/2"	9.2	90	43.5	56.5	16.0	14.0	0.19
3/4"	12.5	90	47	58	15.0	10.7	0.26
1"	16.0	103	50	71	17.4	17.0	0.43
1 1/4"	20.0	103	57	78	19.0	16.7	0.66
1 1/2"	25.0	127	69	83	19.1	16.8	0.88
2"	32.0	127	74.5	100	22.5	19.7	1.42

#### MATERIALS LIST

NO.	PART NAME	MATERIAL	Q'TY
1	Body	CF8M / WCB	1
2	Cap	CF8M / WCB	1
3	Ball	SUS316/CF8M	1
4	Stem	SUS316	1
5	Stem Nut	SUS 304	1
6	Stem Washer	SUS 304	1
7	Handle	SUS 304	1
8	Seat	PTFE	2
9	Gland	SUS 304	1
10	Stem Packing	PTFE	1
11	Stem seal	PTFE	1
12	Handle Sleeve	VINYL	1
13	Joint Gasket	PTFE	1
14	Locking Device	SUS 304	1

‡ Available as an option

### SERIES 20-10

Full Port

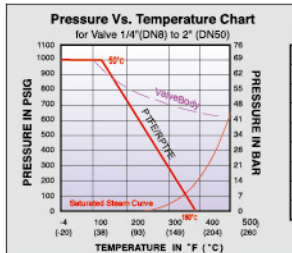
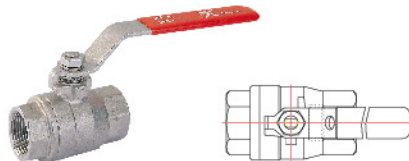
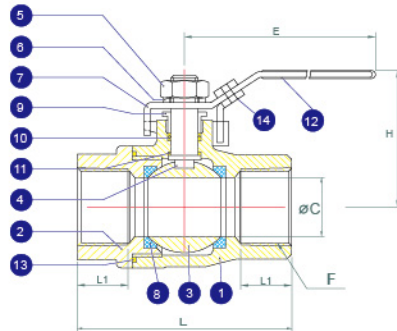

#### DIMENSIONS (mm)

SIZE	øC	E	H	L1	L	F	WL(Kg)
1/4"	11.5	100	50	13	55	1/4" NPT or BSP	0.23
3/8"	12.5	100	50	13	55	3/8" NPT or BSP	0.23
1/2"	15.0	130	60	15	65	1/2" NPT or BSP	0.36
3/4"	20.0	130	64	17	72	3/4" NPT or BSP	0.47
1"	25.0	165	71	19	84	1" NPT or BSP	0.82
1 1/4"	32.0	165	78	22	94	1 1/4" NPT or BSP	1.17
1 1/2"	38.0	190	86	22	110	1 1/2" NPT or BSP	1.82
2"	50.0	190	95	26	126	2" NPT or BSP	2.83

#### MATERIALS LIST

NO.	PART NAME	MATERIAL	Q'TY
1	Body	CF8M / WCB	1
2	End Cap	CF8M / WCB	1
3	Ball	SUS316/CF8M	1
4	Stem	SUS316	1
5	Stem Nut	SUS 304	1
6	Stem Washer	SUS 304	1
7	Handle	SUS 304	1
8	Seat	PTFE	2
9	Gland Nut	SUS 304	1
10	Stem Packing	PTFE	§
11	Stem seal	PTFE	1
12	Handle Sleeve	VINYL	1
13	Joint Gasket	PTFE	1
14	Locking Device	SUS 304	1

§ 1/4" - 3/8" regular 1pc stem packing is used instead  
 ¶ 1/2" - 2" set of v-ring packing consists of 2pcs of v-ring  
 ‡ Available as an option  
 Note: For carbon steel version replace item No. 1 & No. 2 with

### SERIES 20-20

Full Port

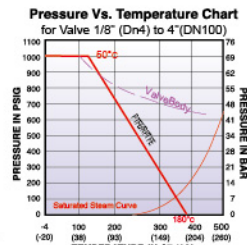
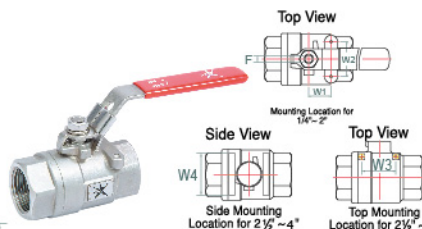
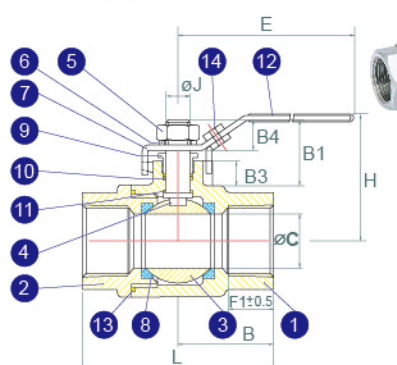

SIZE	B	B1	B3	B4	øC	øJ	E	F	F1	H	L	W1	W2	W3	W4	WL(Kg)
1/8"	27.5	22.3	8	9.8	8	8	100	5.0	10	50	55	12.7	28.5			0.27
1/4"	27.5	22.3	8	9.8	11.6	8	100	5.0	15	50	55	12.7	28.5			0.27
3/8"	27.5	22.3	8	9.8	12.5	8	100	5.0	15	50	55	12.7	28.5			0.27
1/2"	32.5	25.8	10.5	11	15.0	9.5	130	6.5	16	60	65	12.7	28.5			0.40
3/4"	37.3	25.8	10.5	11	20.0	9.5	130	6.5	17	64	74.8	22.4	35.0			0.54
1"	44.0	31.5	11.5	13.5	25.0	11	165	8.0	20.4	71	88	23.4	35.0			0.94
1 1/4"	51.0	31.5	11.5	13.5	32.0	11	165	8.0	22	78	102	25.4	38.1			1.34
1 1/2"	55.0	35.1	12	15.8	38.0	14	190	9.7	22.5	86	110	25.4	38.1			1.93
2"	62.5	30.8	9.5	15.8	50.0	14	190	9.7	26	95	125	25.4	38.1	59	61	3.03
2 1/2"	80.3	54.2	17	24.5	65.0	19	250	12.0	31	130	160.8			70	71	6.59
3"	89.0	55.2	18	24.5	80.0	19	250	12.0	34	148	178			100	78.5	9.28
4"	120.0	57.4	20.8	24.5	100.0	19	280	15.0	43	176	240					20.58

#### MATERIALS LIST

NO.	PART NAME	MATERIAL	Q'TY
1	Body	CF8M / WCB	1
2	End Cap	CF8M / WCB	1
3	Ball	SUS316/CF8M	1
4	Stem	SUS316	1
5	Stem Nut	SUS 304	1
6	Stem Washer	SUS 304	1
7	Handle	SUS 304	1
8	Seat	PTFE	2
9	Gland Nut	SUS 304	1
10	Stem Packing	PTFE	§
11	Stem seal	PTFE	1
12	Handle Sleeve	VINYL	1
13	Joint Gasket	PTFE	1
14	Locking Device	SUS 304	1

§ 1/4" - 3/8" regular 1pc stem packing is used instead  
 ¶ 1/2" - 3" 1 set of v-ring packing consists of 2pcs of v-ring  
 ‡ Available as an option

**SERIES 20-30 2000/1500 PSI**

**Reduced Port**



**Top View**

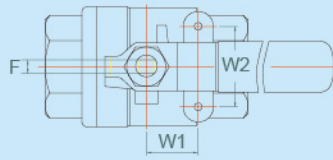

**MATERIALS LIST**

NO.	PART NAME	MATERIAL	QTY
1	Body	CF8M / WCB	1
2	End Cap	CF8M / WCB	1
3	Ball	SUS316/CF8M	1
4	Stem	SUS316	1
5	Stem Nut	SUS 304	1
6	Stem Washer	SUS 304	1
7	Handle	SUS 304	1
8	Seat	RPTFE/PTFE	2
9	Gland Nut	SUS 304	1
10	Stem Packing	PTFE	§
11	Stem Seal	PTFE	1
12	Handle Sleeve	VINYL	1
13	Joint Gasket	PTFE	1
14	Locking Device	SUS 304	1

§ 1/4" ~ 3/8" regular 1pc stem packing is used instead  
 1/2" ~ 2" 1 set of v-ring packing consists of 2pcs of v-ring  
 § Available as an option

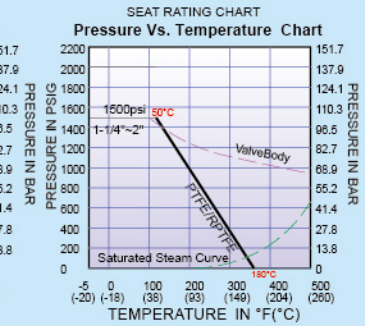
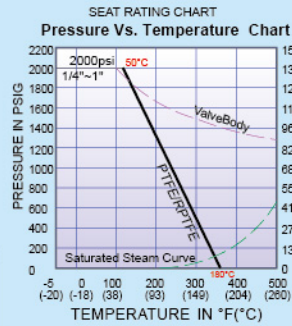
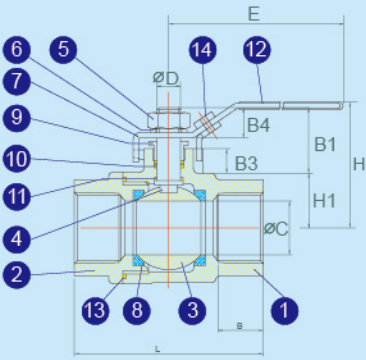

**DIMENSIONS (mm)**

SIZE	B	B1	B3	B4	ØC	ØD	E	F	H	L	W1	W2	Wt.(Kg)
1/4"	11	17.7	6	8	9.5	8	100	5.0	50	51	12.7	28.5	0.22
3/8"	11	17.7	6	8	9.5	8	100	5.0	50	51	12.7	28.5	0.22
1/2"	15	22.6	8	9.8	12.5	8	100	5.0	50	59.5	12.7	28.5	0.28
3/4"	16.5	25	10.5	11	15.0	9.5	130	6.5	53	70	22.4	35.0	0.45
1"	19.5	25	9	11	20.0	9.5	130	6.5	64	84	22.4	35.0	0.66
1 1/4"	20	33	13	13.5	25.0	11	165	8.0	66	91	22.4	35.0	1.08
1 1/2"	22	31	11.5	13.5	32.0	11	165	8.0	79	104	25.4	38.1	1.49
2"	23	31.6	9	15.6	38.0	14	190	9.7	83	117	25.4	38.1	2.32

**SERIES 20-40 2000/1500 PSI**

**Full Port**

**MATERIALS LIST**

NO.	PART NAME	MATERIAL	QTY
1	Body	CF8M / WCB	1
2	End Cap	CF8M / WCB	1
3	Ball	SUS316/CF8M	1
4	Stem	SUS316	1
5	Stem Nut	SUS 304	1
6	Stem Washer	SUS 304	1
7	Handle	SUS 304	1
8	Seat	RPTFE	2
9	Gland Nut	SUS 304	1
10	Stem Packing	PTFE	§
11	Stem Seal	PTFE	1
12	Handle Sleeve	VINYL	1
13	Joint Gasket	PTFE	1
14	Locking Device	SUS 304	1

§ 1/4" ~ 3/8" regular 1pc stem packing is used instead  
 1/2" ~ 2" 1 set of v-ring packing consists of 2pcs of v-ring  
 § Available as an option



**Top View**

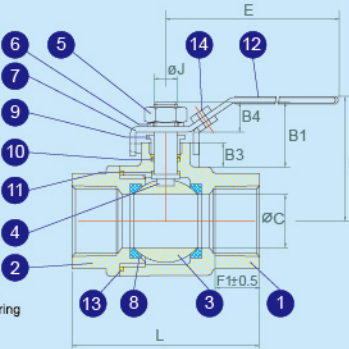
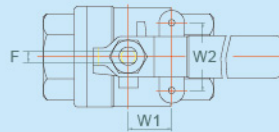

**DIMENSIONS (mm)**

SIZE	B1	B3	B4	ØC	ØJ	E	F	F1	H	L	W1	W2	Wt.(kg)
1/4"	22.3	8	9.8	11.5	8	100	5.0	15	50	55	12.7	28.5	0.23
3/8"	22.3	8	9.8	12.5	8	100	5.0	15	50	55	12.7	28.5	0.23
1/2"	25.6	10.5	11	15.0	9.5	130	6.5	16	60	65	12.7	28.5	0.38
3/4"	25.6	10.5	11	20.0	9.5	130	6.5	17	64	74.6	22.4	35.0	0.52
1"	31.5	11.5	13.5	25.0	11	165	8.0	20.4	71	88	23.4	35.0	0.92
1 1/4"	31.5	11.5	13.5	32.0	11	165	8.0	22	78	102	25.4	38.1	1.32
1 1/2"	35.1	12	15.6	38.0	14	190	9.7	22.5	86	110	25.4	38.1	1.90
2"	30.6	9.5	15.6	50.0	14	190	9.7	26	95	125	25.4	38.1	3.12

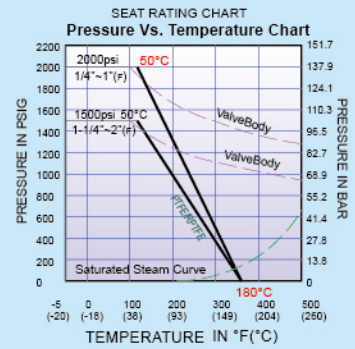

**SERIES 20-50 SERIES 20-50**

**Full Port**

NO.	PART NAME	MATERIAL	QTY
1	Body	ASTM A351 Gr. CF8M	1
2	End Cap	ASTM A351 Gr. CF8M	1
3	Ball	SUS316/CF8M	1
4	Stem	SUS316	1
5	Stem Nut	SUS 304	2
6	Belleville Washer	SUS 301	2
7	Handle	SUS 304	1
8	Seat	PTFE	2
9	Gland	SUS 304	1
10	Stem Packing	PTFE	§
11	Stem Seal	PTFE	1
12	Handle Sleeve	VINYL	1
13	Joint Gasket	PTFE	1
14	Locking Device	SUS 304	1
15	Stop Pin	SUS 304	1
16	Lock Saddle	SUS 304	1

§ 1 Set of v-ring packing consists of 2pcs of v-ring

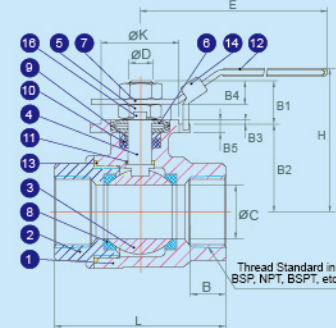
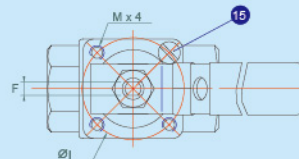

**DIMENSIONS (mm)**

SIZE	B	B1	B2	B3	B4	B5	ØC	ØD	E	F	H	ØI	ØK	L	M	Wt. (kg)	ISO5211
1/4"	15	17.9	27.5	2	10.0	5	11.5	9.5	130	6.5	69	36	25	65.0	M5	-	F03
3/8"	15	17.9	27.5	2	10.0	5	12.5	9.5	130	6.5	69	36	25	65.0	M5	0.47	F03
1/2"	16	17.9	27.5	2	10.0	5	15.0	9.5	130	6.5	69	36	25	65.0	M5	0.43	F03
3/4"	17	19.8	32.6	2	11.0	5	20.0	9.5	130	6.5	75	36	25	74.5	M5	0.56	F03
1"	20	16.2	44.0	2	9.0	6	25.0	11.0	160	8.0	90	42	30	88.0	M5	0.99	F04
1 1/4"	22	16.1	49.6	2	8.4	6	32.0	11.0	160	8.0	96	42	30	102.0	M5	-	F04
1 1/2"	22.5	22.9	54.1	2	10.4	6	38.0	14.0	207	9.7	105	50	35	110.0	M6	2.06	F05
2"	28	23	62.5	2	10.5	6	50.0	14.0	207	9.7	114	50	35	127.5	M6	3.11	F05
2 1/2"	31	29.9	83.6	2	15.3	8	65.0	19.0	260	12.0	154	70	55	160.6	M8	7.08	F07
3"	34	31.6	92.3	2	17	8	80.0	19.0	260	12.0	183	102	70	178.0	M10	9.74	F10

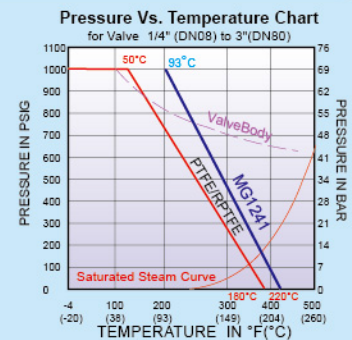

**MARS VALVE CO., LTD.**  
**TRANSWORLD STEEL ENT.CO., LTD.**  
 No. 83, Sec. 1, Chung De 8th Road,  
 Taichung, 406, Taiwan R.O.C  
**TEL: +886-4-2246-3808**  
**FAX: +886-4-2247-0912**  
 E-mail: mars@marsvalve.com.tw  
<http://www.marsvalve.com.tw>

Distributed by: