

GEMÜ B22

Manually operated 2/2-way ball valve



Features

- Suitable for vacuum applications
- Low maintenance and reliable spindle sealing
- Antistatic device

Description

The GEMÜ B22 3-piece 2/2-way metal ball valve is manually operated. It has a plastic sleeved hand lever with a locking device. The seat seal is made of PTFE.

Technical specifications

- **Media temperature:** -20 to 180 °C
- **Ambient temperature:** -20 to 60 °C
- **Operating pressure :** 0 to 63 bar
- **Nominal sizes:** DN 8 to 100
- **Body configurations:** 2/2-way body
- **Connection types:** Flange | Spigot | Threaded connection
- **Connection standards:** ASME | DIN | EN | ISO | NPT
- **Body materials:** 1.4408, investment casting material
- **Seal materials:** PTFE
- **Conformities:** ATEX

Technical data depends on the respective configuration



Product line

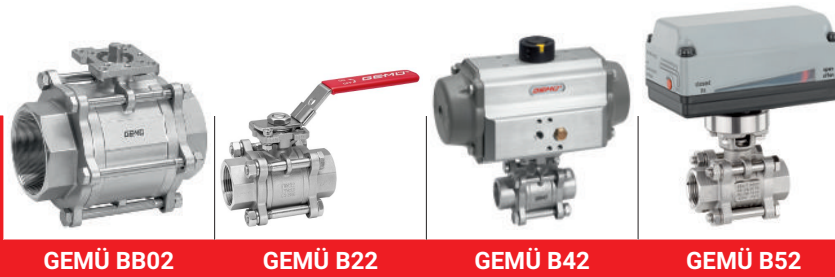

Operation				
With bare shaft	●	-	-	-
Manual	-	●	-	-
Pneumatic	-	-	●	-
Motorized	-	-	-	●
Nominal sizes	DN 8 to 100	DN 8 to 100	DN 8 to 100	DN 8 to 100
Media temperature	-20 to 180 °C	-20 to 180 °C	-20 to 180 °C	-20 to 180 °C
Operating pressure	0 to 63 bar	0 to 63 bar	0 to 63 bar	0 to 63 bar
Connection types				
Flange	●	●	●	●
Spigot	●	●	●	●
Threaded connection	●	●	●	●

* depending on version and/or operating parameters

Product description

Construction

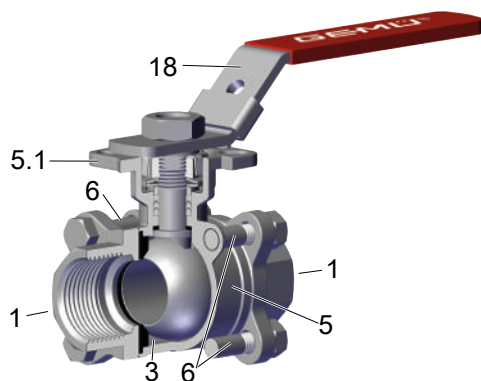

Item	Name	Materials
5	Ball valve body	1.4408 / CF8M
1	Pipe connections	1.4408 / CF8M , 1.4409 / CF3M butt weld connections
5.1	Mounting flange ISO 5211	1.4408 / CF8M
18	Hand lever	1.4408 / CF8M
6	Studs	A2 70
3	Seal	PTFE

Pressure-relief hole

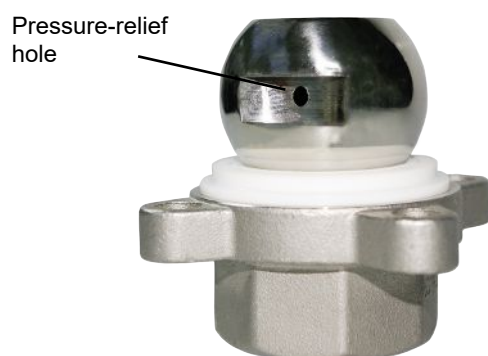

Control ball

Control ball	Code U	Code Y	Code W

Note: The control ball cannot be retrofitted to standard 2/2-way bodies at a later date.

The spindle seal system

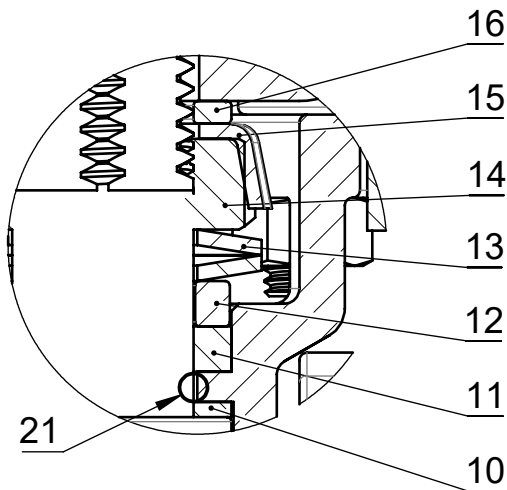

Item	Name	Material
10	Seal	PTFE
11	V-ring	PTFE
12	Stainless steel sleeve	SS304-1.4301
13	Spring washer	SS304-1.4301
14	Spindle nut	A2 70
15	Cap	SS304-1.4301
16	Washer	SS304-1.4301
21	O-ring (spindle seal)	Viton

Long service life due to triple spindle seal

- Conical spindle seal:

The seal **10** arranged at an angle of 45° effectively prevents the leakage of media when operating the spindle

- O-ring:

Stabilising spindle seal **21** with low wear and long service life

- Pretensioned self-adjusting spindle seal:

The spindle packing consists of several V-rings **11**, a spring washer **13** and a stainless steel sleeve **12**. The spring washer **13** is pretensioned via the spindle nut **14**. The pretension force is distributed to the V-rings **11** via the stainless steel sleeve **12**, thereby preventing the leakage of media. The pretension provides low maintenance and reliable spindle sealing even after a long service life.

GEMÜ CONEXO

The interaction of valve components that are equipped with RFID chips and an associated IT infrastructure actively increase process reliability.



Thanks to serialization, every valve and every relevant valve component such as the body, actuator or diaphragm, and even automation components, can be clearly traced and read using the CONEXO pen RFID reader. The CONEXO app, which can be installed on mobile devices, not only facilitates and improves the "installation qualification" process, but also makes the maintenance process much more transparent and easier to document. The app actively guides the maintenance technician through the maintenance schedule and directly provides him with all the information assigned to the valve, such as test reports, testing documentation and maintenance histories. The CONEXO portal acts as a central element, helping to collect, manage and process all data.

For further information on GEMÜ CONEXO please visit:

www.gemu-group.com/conexo

Ordering

GEMÜ Conexo must be ordered separately with the ordering option "CONEXO" (see order data).

Installing the RFID chip

In the corresponding design with CONEXO, this product has an RFID chip (1) for electronic recognition. The position of the RFID chip can be seen below.

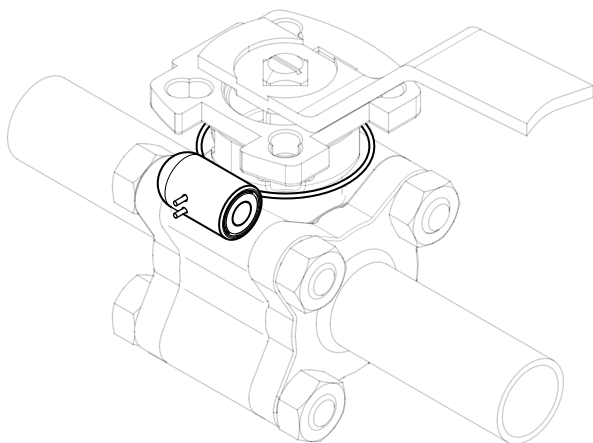

Application

- Heating systems
- Beverage industry
- Foodstuff industry
- Chemical industry
- Drinking water installations
- Processing industry
- HVAC

Availability

Connection types ¹⁾	Ball valve material ²⁾	
	Code 37	Code C7
Spigot (Code 19, 59, 60)	-	X
Threaded socket (Code 1, 31)	X	-
Flange (Code 8, 11)	X	-

1) Connection type

Code 1: Threaded socket DIN ISO 228

Code 31: Threaded socket NPT

Code 8: Flange EN 1092, PN 16, form B, face-to-face dimension FTF EN 558 series 1, ISO 5752, basic series 1

Code 11: Flange EN 1092, PN 40, form B, face-to-face dimension FTF EN 558 series 1, ISO 5752, basic series 1

Code 19: Spigot DIN EN 12627

Code 59: Spigot ASME BPE

Code 60: Spigot ISO 1127 / EN 10357, series C

2) Ball valve material

Code 37: 1.4408 / CF8M (body, connection), 1.4401 / SS316 (ball, shaft)

Code C7: 1.4408 / CF8M (body), 1.4409 / CF3M (connection), 1.4401 / SS316 (ball, shaft)

Order data

The order data provide an overview of standard configurations.

Please check the availability before ordering. Other configurations available on request.

Order codes

1 Type	Code
Ball valve, metal, manually operated, 3-piece, ISO 5211, top flange, lockable hand lever	B22

2 DN	Code
DN 8	8
DN 10	10
DN 15	15
DN 20	20
DN 25	25
DN 32	32
DN 40	40
DN 50	50
DN 65	65
DN 80	80
DN 100	100

3 Body/ball configuration	Code
2/2-way body	D
2/2-way body, V-ball 30° (for Kv value see datasheet)	U
2/2-way body, V-ball 90° (for Kv value see datasheet)	W
2/2-way body, V-ball 60° (for Kv value see datasheet)	Y

4 Connection type	Code
Spigot	
Spigot DIN EN 12627	19
Spigot ASME BPE	59
Spigot ISO 1127 / EN 10357, series C	60

4 Continuation of Connection type	Code
Threaded socket	
Threaded socket DIN ISO 228	1
Threaded socket NPT	31
Flange	
Flange EN 1092, PN 16, form B, face-to-face dimension FTF EN 558 series 1, ISO 5752, basic series 1	8
Flange EN 1092, PN 40, form B, face-to-face dimension FTF EN 558 series 1, ISO 5752, basic series 1	11

5 Ball valve material	Code
1.4408 / CF8M (body, connection), 1.4401 / SS316 (ball, shaft)	37
1.4408 / CF8M (body), 1.4409 / CF3M (connection), 1.4401 / SS316 (ball, shaft)	C7

6 Seal material	Code
PTFE	5

7 Control function	Code
Manually operated, hand lever, lockable	L

8 Special version	Code
Without	
ATEX version	X

9 CONEXO	Code
without	
Integrated RFID chip for electronic identification and traceability	C

Order example

Order option	Code	Description
1 Type	B22	Ball valve, metal, manually operated, 3-piece, ISO 5211, top flange, lockable hand lever
2 DN	15	DN 15
3 Body/ball configuration	D	2/2-way body
4 Connection type	1	Threaded socket DIN ISO 228
5 Ball valve material	37	1.4408 / CF8M (body, connection), 1.4401 / SS316 (ball, shaft)
6 Seal material	5	PTFE
7 Control function	L	Manually operated, hand lever, lockable
8 Special version		Without
9 CONEXO	C	Integrated RFID chip for electronic identification and traceability

Technical data

Medium

Working medium: Corrosive, inert, gaseous and liquid media and steam which have no negative impact on the physical and chemical properties of the body and seal material.

Temperature

Media temperature: Connection code 19, 59, 60 -10 to 180 °C
 Connection code 1, 31, 8, 11 -20 to 180 °C

Ambient temperature: -20 to 60 °C

Storage temperature: 0 to 40 °C

Pressure

Operating pressure: 0 to 63 bar

Pressure/temperature diagram:

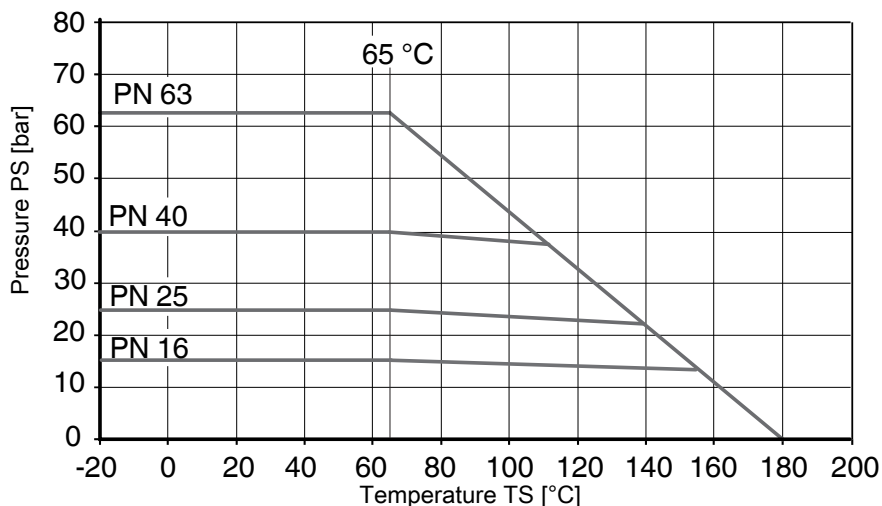

Note media temperature

Leakage rate: Leakage rate according to ANSI FCI70 – B16.104
 Leakage rate according to EN12266, 6 bar air, leakage rate A

Kv values:

DN	NPS	Kv values
8	1/4"	8
10	3/8"	8
15	1/2"	17
20	3/4"	34
25	1"	60
32	1¼"	94
40	1½"	213
50	2"	366
65	2½"	595
80	3"	935
100	4"	1700

Kv values in m³/h

Kv values:

V-ball 30° (code U)

DN	NPS	Opening angle										
		0	15%	20%	30%	40%	50%	60%	70%	80%	90%	100%
8	1/4"	0	0.019	0.044	0.088	0.151	0.232	0.327	0.446	0.576	0.727	0.885
10	3/8"	0	0.021	0.05	0.1	0.172	0.265	0.374	0.51	0.659	0.83	1.012
15	1/2"	0	0.085	0.085	0.17	0.255	0.425	0.68	0.935	1.36	1.87	2.21
20	3/4"	0	0.085	0.17	0.425	0.595	0.935	1.53	2.04	2.805	3.825	4.59
25	1"	0	0.085	0.255	0.68	1.105	1.955	2.975	4.335	8.33	7.225	8.5
32	1 1/4"	0	0.17	0.34	0.935	1.7	3.145	4.675	6.8	8.5	11.05	12.75
40	1 1/2"	0	0.255	0.51	1.36	2.55	4.25	6.375	9.35	11.9	14.45	17
50	2"	0	0.34	1.02	3.23	5.1	8.5	12.75	19.55	26.35	36.55	51
65	2 1/2"	0	0.34	0.85	3.4	6.8	10.2	15.3	23.8	31.45	52.7	63.75
80	3"	0	0.425	1.02	3.4	6.8	11.9	19.55	28.05	39.1	55.25	69.7
100	4"	0	0.51	1.7	5.1	12.75	24.65	40.8	60.35	85	110.5	135.2

Kv values in m³/h

V-ball 60° (code V)

DN	NPS	Opening angle										
		0	15%	20%	30%	40%	50%	60%	70%	80%	90%	100%
8	1/4"	0	0.026	0.06	0.141	0.249	0.372	0.539	0.762	1.034	1.38	1.845
10	3/8"	0	0.03	0.068	0.161	0.285	0.425	0.616	0.871	1.182	1.577	2.108
15	1/2"	0	0.085	0.085	0.255	0.425	0.765	1.19	1.7	2.805	3.74	5.1
20	3/4"	0	0.085	0.17	0.595	0.85	1.445	2.38	3.4	5.525	7.65	10.2
25	1"	0	0.17	0.34	0.935	1.53	2.89	4.505	6.715	10.46	13.01	17.85
32	1 1/4"	0	0.17	0.51	1.53	2.55	4.675	8.075	10.88	16.15	22.1	33.15
40	1 1/2"	0	0.34	0.68	2.125	3.4	6.8	11.05	16.15	22.95	34	44.2
50	2"	0	0.34	1.275	3.91	7.65	14.03	22.95	33.15	46.75	70.55	93.5
65	2 1/2"	0	0.34	1.275	4.25	8.5	17.85	28.9	45.05	63.75	87.55	127.5
80	3"	0	0.425	2.125	5.1	11.9	21.25	34	55.25	77.35	108.8	140.3
100	4"	0	0.595	2.55	9.35	21.25	34	50.15	76.5	119.9	180.2	302.6

Kv values in m³/h

V-ball 90° (code W)

DN	NPS	Opening angle										
		0	15%	20%	30%	40%	50%	60%	70%	80%	90%	100%
8	1/4"	0	0.037	0.086	0.212	0.39	0.658	1.008	1.391	1.837	2.332	3.012
10	3/8"	0	0.043	0.098	0.242	0.446	0.752	1.152	1.59	2.1	2.665	3.443
15	1/2"	0	0.085	0.17	0.34	0.51	0.765	1.275	1.87	3.23	4.59	5.865
20	3/4"	0	0.17	0.34	0.68	1.02	1.7	2.635	3.91	6.8	9.605	11.9
25	1"	0	0.17	0.51	1.53	2.89	4.335	6.885	9.69	13.6	17.85	24.65
32	1 1/4"	0	0.255	0.68	1.7	4.25	6.8	11.9	16.15	23.8	33.15	46.75
40	1 1/2"	0	0.425	0.765	2.975	5.95	11.05	17	26.35	35.7	53.55	66.3
50	2"	0	0.595	1.7	5.1	10.2	18.7	29.75	38.25	59.5	89.25	114.8
65	2 1/2"	0	0.425	1.445	5.95	11.9	23.8	40.8	59.5	90.1	136	185.3
80	3"	0	0.595	2.975	6.8	15.3	29.75	51	76.5	114.8	174.3	263.5
100	4"	0	0.85	2.975	13.6	34	63.75	106.3	161.5	250.8	375.7	569.5

Kv values in m³/h

Pressure rating:

DN	Connection type code ¹⁾					
	60	19	1, 31	11	8	59
8	PN63	PN63	PN63	-	-	-
10	PN63	PN63	PN63	-	-	-
15	PN63	PN63	PN63	PN40	-	PN63
20	PN63	PN63	PN63	PN40	-	PN63
25	PN63	PN63	PN63	PN40	-	PN63
32	PN63	PN63	PN63	PN40	-	-
40	PN63	PN63	PN63	PN40	-	PN63
50	PN63	PN63	PN63	PN40	-	PN63
65	PN40	PN40	PN40	PN40	-	PN40
80	PN40	PN40	PN40	-	PN16	PN40
100	PN25	PN25	PN25	-	PN16	PN25

1) **Connection type**

Code 1: Threaded socket DIN ISO 228

Code 31: Threaded socket NPT

Code 8: Flange EN 1092, PN 16, form B, face-to-face dimension FTF EN 558 series 1, ISO 5752, basic series 1

Code 11: Flange EN 1092, PN 40, form B, face-to-face dimension FTF EN 558 series 1, ISO 5752, basic series 1

Code 19: Spigot DIN EN 12627

Code 59: Spigot ASME BPE

Code 60: Spigot ISO 1127 / EN 10357, series C

Product conformities

Pressure Equipment Directive: 2014/68/EU

Explosion protection: ATEX (2014/34/EU), order code Special version X

ATEX assessment:

External
 Gas: Zone 1, 2 IIB
 Dust: Zone 21, 22 IIIC

Internal
Up to DN 65
 Gas: Zone 0, 1, 2 IIC
 Dust: No zone

DN 80 and 100
 Gas: Zone 0, 1, 2 IIB
 Dust: No zone

Mechanical data

Torques:

DN	NPS	Breakaway torque
8	1/4"	6
10	3/8"	6
15	1/2"	6
20	3/4"	10
25	1"	11
32	1¼"	17
40	1½"	28
50	2"	53
65	2½"	76
80	3"	89
100	4"	138

Torques in Nm

A safety factor of 1.2 is included

With dry, non-lubricating media the breakaway torque may be increased.

Valid for clean, non-particulate and oil-free media (water, alcohol, etc.), gas or saturated steam (clean and wet).
PTFE seal.

Weight:

Ball valve

DN	NPS	Threaded connection, spigot	Flange
8	1/4"	0.55	1.15
10	3/8"	0.55	1.15
15	1/2"	0.6	1.35
20	3/4"	0.7	1.45
25	1"	0.8	1.8
32	1¼"	1.2	2.4
40	1½"	2.3	3.5
50	2"	3.5	4.9
65	2½"	6.9	9.3
80	3"	11.7	14.7
100	4"	19.3	22.3

Weights in kg

Hand lever

DN	Designation	Weight
DN 8 - 20	AB22 20D	0.122
DN 25 - 32	AB22 32D	0.165
DN 40 - 50	AB22 50D	0.398
DN 65	AB22 65D	0.78
DN 80 - 100	AB22 80D	0.78

Weights in kg

Dimensions

Actuator flange

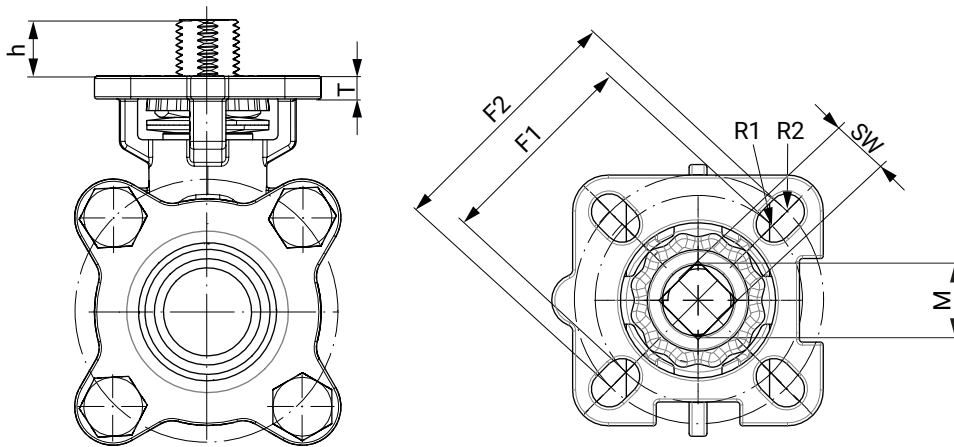

	G	F1	ISO 5211	R1	F2	ISO 5211	R2	SW	h	T	M
8	1/4"	36.0	F03	3.0	42.0	F04	3.0	9.0	9.5	5.5	M12
10	3/8"	36.0	F03	3.0	42.0	F04	3.0	9.0	9.5	5.5	M12
15	1/2"	36.0	F03	3.0	42.0	F04	3.0	9.0	9.5	5.5	M12
20	3/4"	36.0	F03	3.0	42.0	F04	3.0	9.0	7.5	5.5	M12
25	1"	42.0	F04	3.5	50.0	F05	3.5	11.0	13.0	7.0	M14
32	1¼"	42.0	F04	3.5	50.0	F05	3.5	11.0	13.0	6.5	M14
40	1½"	50.0	F05	4.5	70.0	F07	3.5	14.0	15.0	7.5	M18
50	2"	50.0	F05	4.5	70.0	F07	3.5	14.0	16.0	8.5	M18
65	2½"	50.0	F07	4.5	70.0	F10	3.5	17.0	18.0	8.5	M22
80	3"	70.0	F07	5.5	102.0	F10	4.5	17.0	18.0	10.5	M22
100	4"	102.0	F10	5.5	125.0	F12	4.5	17.0	18.0	10.5	M22

Dimensions in mm

Body dimensions

Flange (connection code 8, 11)

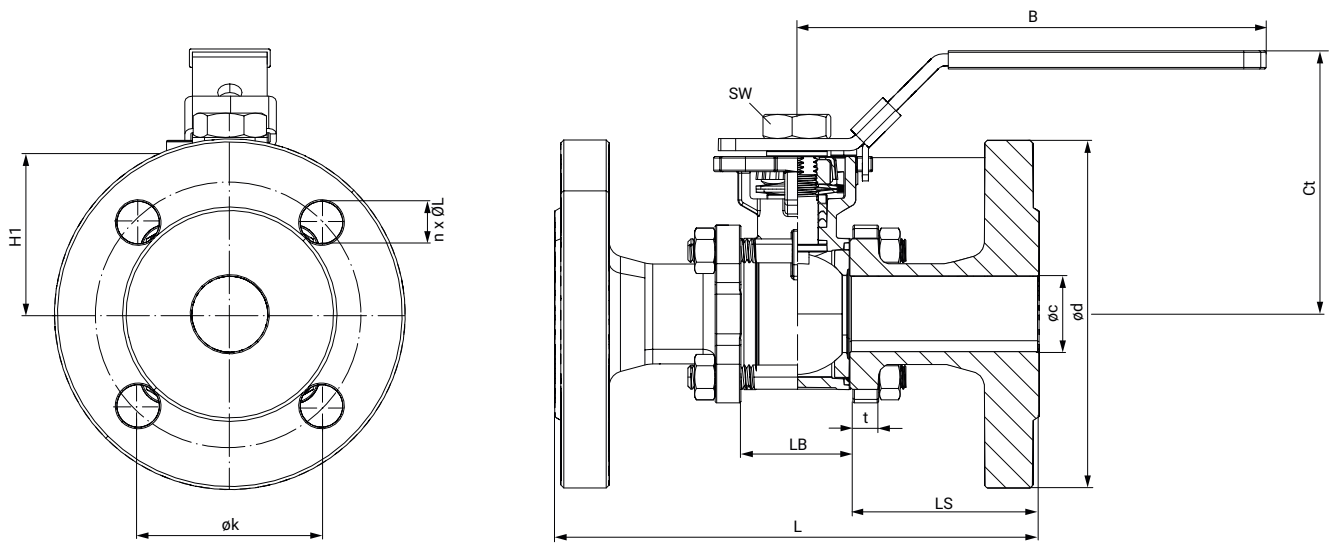

DN	Conne- tion code	ϕc	ϕd	ϕk	t	L	LB	LS	H1	n x ϕL
15	11	15.0	95.0	65.0	8.5	130.0	24.0	53.0	40.5	4 x 14.0
20	11	20.0	105.0	75.0	9.0	150.0	29.0	60.5	49.5	4 x 14.0
25	11	25.0	115.0	85.0	9.5	160.0	35.0	62.5	57.5	4 x 14.0
32	11	32.0	140.0	100.0	10.0	180.0	44.0	68.0	61.6	4 x 18.0
40	11	38.0	150.0	110.0	11.0	200.0	53.0	73.5	76.1	4 x 18.0
50	11	50.0	165.0	125.0	11.5	230.0	65.0	82.5	83.4	4 x 18.0
65	11	65.0	185.0	145.0	13.0	290.0	81.0	104.5	95.1	8 x 18.0
80	8	80.0	200.0	160.0	14.5	310.0	96.0	107.0	110.0	8 x 18.0
100	8	100.0	220.0/235 .0	180.0	15.5	350.0	124.0	113.0	125.0	8 x 18.0

Dimensions in mm

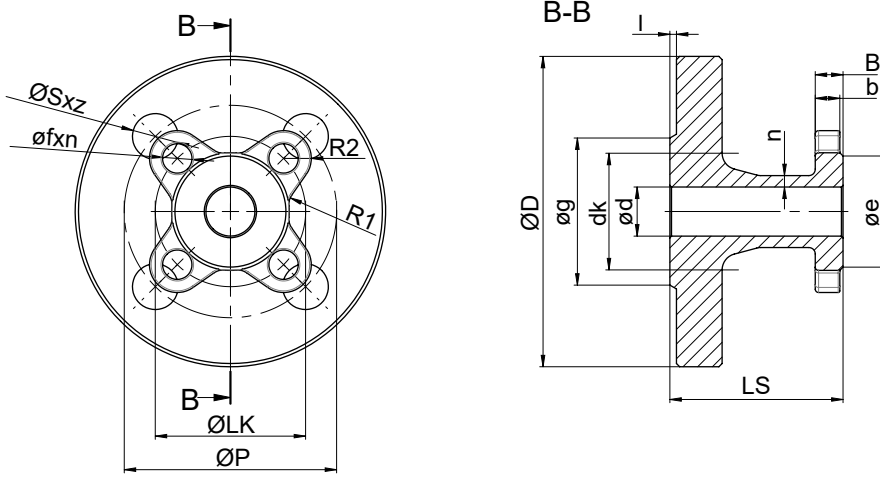

DN	Connection code	LK	øf	n	R1	R2	B	b	øe	LS	ød	z	l	n
15	8,11	46.0	9.0	4.0	5.0	8.5	8.5	7.5	34.0	53.0	15.0	4.0	2.0	3.50
20	8,11	51.0	9.0	4.0	5.0	8.5	9.0	8.0	40.0	60.5	20.0	4.0	2.0	3.50
25	8,11	59.0	9.0	4.0	5.0	8.5	9.5	8.5	48.0	62.5	25.0	4.0	2.0	4.00
32	8,11	73.0	11.0	4.0	5.0	10.0	10.0	9.0	59.0	68.0	32.0	4.0	2.0	4.50
40	8,11	83.0	11.0	4.0	5.0	10.0	11.0	10.0	72.0	73.5	38.0	4.0	3.0	4.50
50	8,11	90.0	11.0	4.0	6.0	10.0	11.5	10.5	87.0	82.5	50.0	4.0	3.0	5.00
65	8,11	130.0	13.5	4.0	15.0	11.5	13.0	12.0	113.0	104.5	65.0	4.0/8.0	3.0	6.00
80	8,11	155.0	15.5	4.0	20.0	13.5	14.5	13.5	136.0	107.0	80.0	8.0	3.0	6.25
100	8,11	187.0	15.5	8.0	20.0	13.5	15.5	14.5	168.0	113.0	100.0	8.0	3.0	6.50

Dimensions in mm

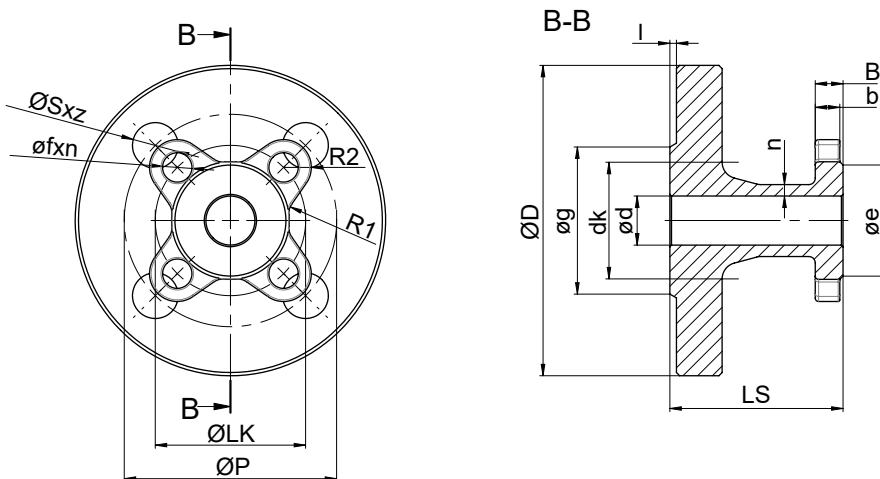

DN	Connection Code	øS	ØD	øg	ØP
15	11	14.0	95.0	45.0	65.0
20	11	14.0	105.0	58.0	75.0
25	11	14.0	115.0	68.0	85.0
32	11	18.0	140.0	78.0	100.0
40	11	18.0	150.0	88.0	110.0

Dimensions

DN	Con- tion Code	ØS	ØD	øg	ØP
50	11	18.0	165.0	102.0	125.0
65	11	18.0	185.0	122.0	145.0
80	8	18.0	200.0	138.0	160.0
100	8	18.0	220.0	158.0	180.0

Dimensions in mm

Threaded socket (connection code 1, 31)

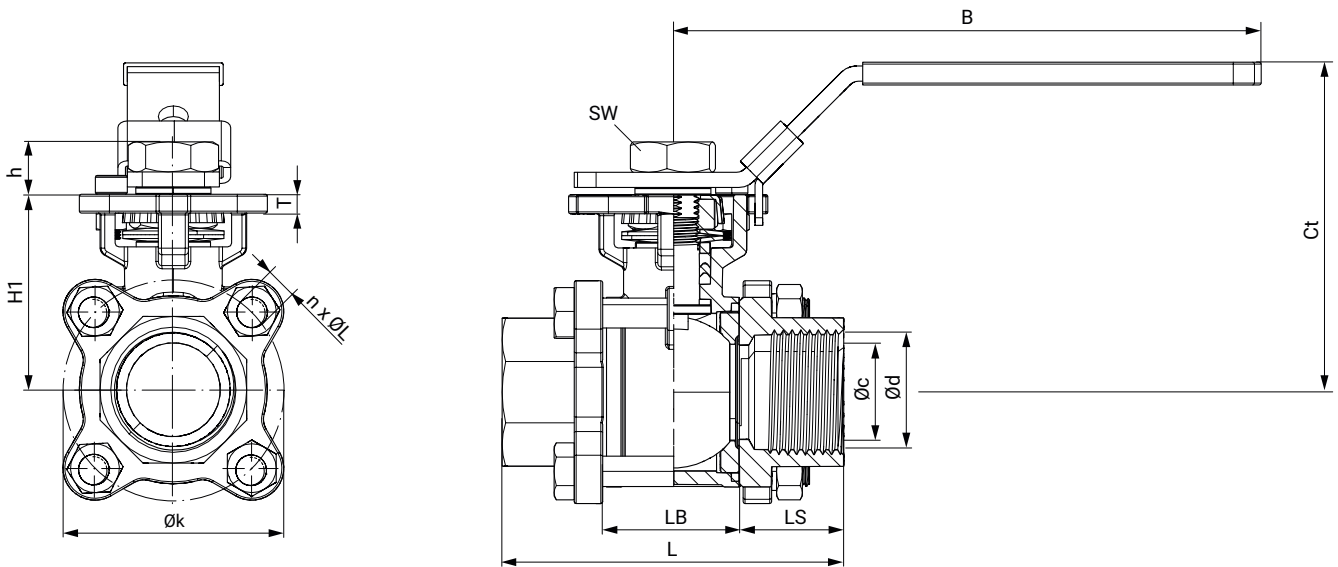

DN	G	øc	øk	T	L	LB	LS	H1	n x ØL	s	SW	B	Ct
8	1/4"	10.0	46.0	12.0	55.0	4.0	25.5	45.5	4 x 9.0	2.50	26.0	110.0	72.0
10	3/8"	12.0	46.0	12.0	60.0	9.0	25.5	45.4	4 x 9.0	2.50	26.0	110.0	72.0
15	1/2"	15.0	46.0	16.0	75.0	24.0	25.5	40.5	4 x 9.0	2.50	26.0	126.0	74.0
20	3/4"	20.0	51.0	16.0	80.0	29.0	25.5	49.5	4 x 9.0	2.80	32.0	126.0	77.0
25	1"	25.0	61.0	17.0	90.0	35.0	27.5	57.5	4 x 11.0	2.90	39.0	155.0	97.0
32	1 1/4"	32.0	73.0	20.0	110.0	44.0	33.0	61.6	4 x 11.0	3.25	48.5	155.0	97.0
40	1 1/2"	38.0	83.0	22.0	120.0	53.0	33.5	76.1	4 x 11.0	3.35	54.5	192.0	108.0
50	2"	49.0	101.0	24.0	140.0	65.0	37.5	83.4	4 x 11.0	3.95	67.5	192.0	117.0
65	2 1/2"	64.0	130.0	28.0	185.0	81.0	52.0	95.6	4 x 13.5	4.40	84.0	235.0	136.0
80	3"	76.0	155.0	32.0	205.0	96.0	54.5	110.0	4 x 15.5	5.10	98.0	320.0	148.0
100	4"	100.0	187.0	40.0	240.0	124.0	58.0	125.0	6 x 15.5	7.70	124.0	320.0	162.0

Dimensions in mm

Spigot ASME (connection code 59)

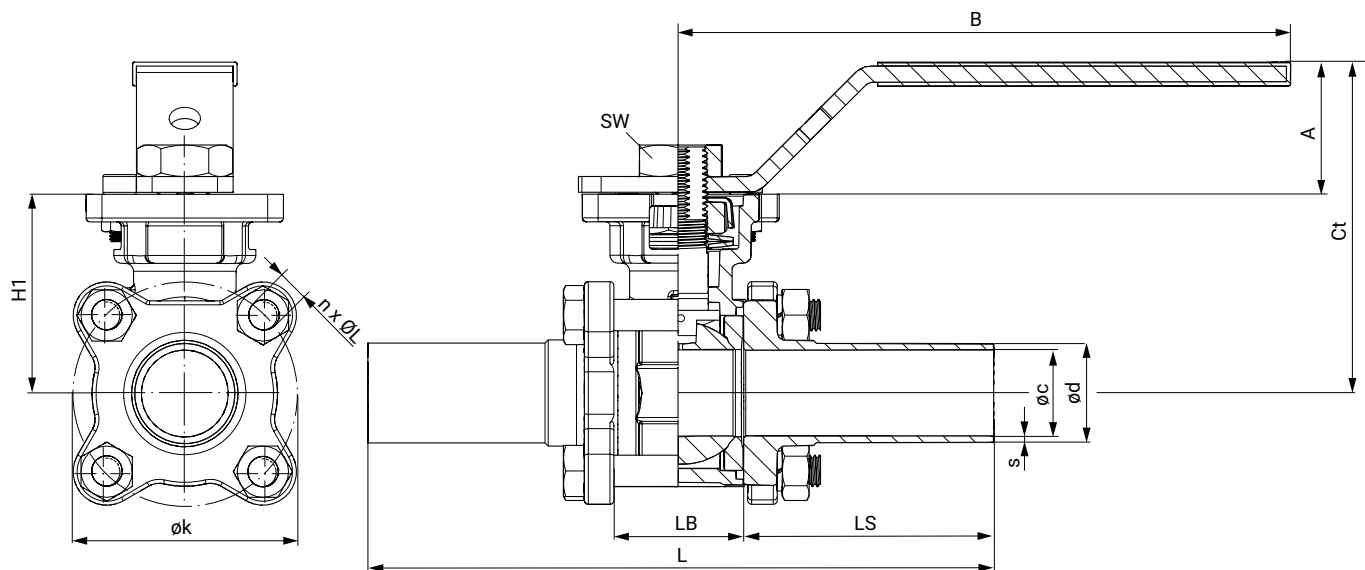

DN	ϕc	ϕd	s	ϕk	L	LB	LS	H1	n x ϕL
15	9.4	12.7	1.65	46.0	140.0	25.0	57.5	40.5	4 x 9.0
20	5.7	19.0	1.65	47.0	146.0	28.0	59.0	49.5	4 x 9.0
25	22.1	25.4	1.65	58.0	159.0	32.0	63.5	57.5	4 x 11.0
40	34.8	38.1	1.65	79.0	191.0	48.0	71.5	76.1	4 x 11.0
50	47.5	50.8	1.65	98.5	216.0	62.0	77.0	83.4	4 x 11.0
65	60.2	63.5	1.65	126.0	248.0	80.0	84.0	95.6	4 x 13.5
80	72.9	76.2	1.65	146.0	267.0	90.0	88.5	110.0	4 x 15.5
100	97.4	101.6	2.10	180.0	318.0	118.0	100.0	125.0	6 x 15.5

Dimensions in mm

Spigot DIN EN 12627 (connection code 19)

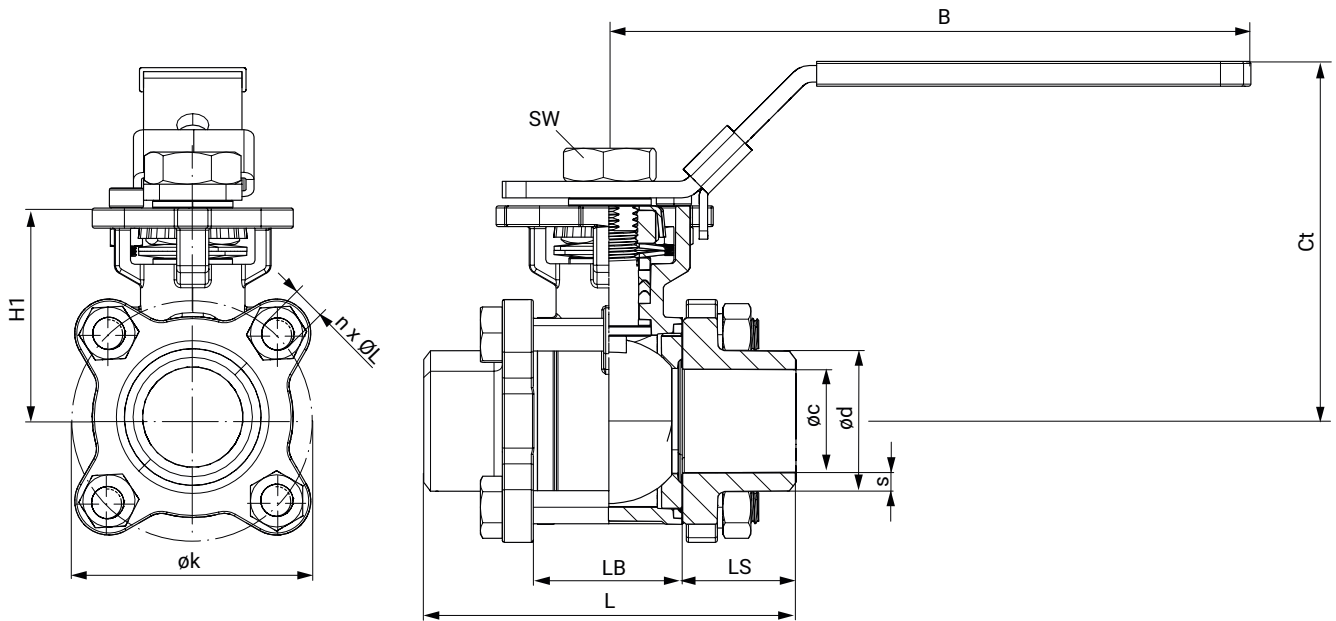

DN	ϕc	ϕd	ϕk	L	LB	LS	H1	$n \times \phi L$	Ct	B
8	11.6	16.2	46.0	60.0	24.0	18.0	45.5	4 x 9.0	72.0	110.0
10	12.7	17.5	46.0	60.0	24.0	18.0	45.4	4 x 9.0	71.4	125.0
15	15.0	21.7	46.0	75.0	24.0	25.5	40.5	4 x 9.0	77.0	120.0
20	20.0	27.2	51.0	80.0	29.0	25.5	49.5	4 x 9.0	81.0	120.0
25	25.0	34.0	61.0	90.0	35.0	27.5	57.5	4 x 11.0	90.0	140.0
32	32.0	42.7	73.0	110.0	44.0	33.0	61.6	4 x 11.0	94.5	140.0
40	38.0	58.8	83.0	100.0	53.0	33.5	76.1	4 x 11.0	104.0	190.0
50	50.0	60.5	101.0	140.0	65.0	37.5	83.4	4 x 11.0	112.0	190.0
65	65.0	76.3	130.0	185.3	81.0	52.0	95.6	4 x 13.5	120.0	230.0
80	80.0	89.0	155.0	205.0	96.0	54.5	110.0	4 x 15.5	132.0	260.0
100	100.0	116.0	187.0	240.0	124.0	56.3	125.0	6 x 15.5	160.0	300.0

Dimensions in mm

Spigot ISO (connection code 60)

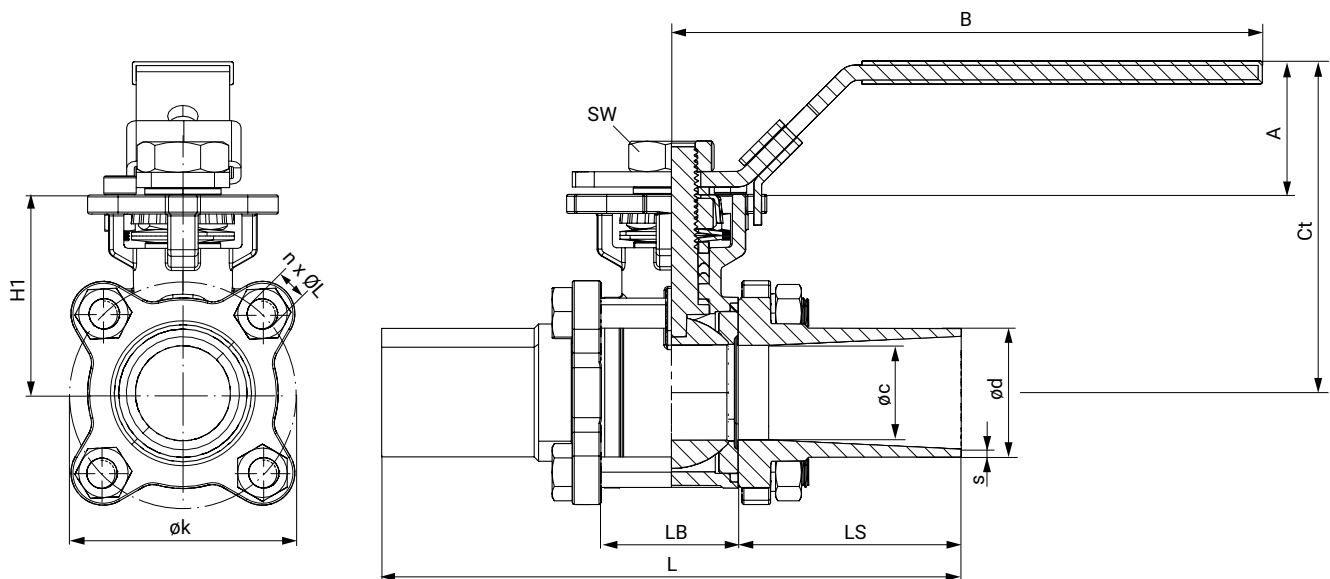

DN	ϕc	ϕd	s	ϕk	L	LB	LS	H1	Ct	B
8	10	13.5	1.6	46.0	120.0	24.0	48.0	45.5	72.0	110.0
10	12	17.2	1.6	46.0	120.0	24.0	48.0	45.4	71.4	125.0
15	15	21.3	1.6	46.0	140.2	24.0	58.0	40.5	77.0	120.0
20	20	26.9	1.6	51.0	140.0	29.0	55.5	49.5	81.0	120.0
25	25	33.7	2.0	61.0	152.2	35.0	58.5	57.5	90.0	140.0
32	32	42.4	2.0	73.0	165.1	44.0	60.5	61.6	94.5	140.0
40	38	48.3	2.0	83.0	190.4	53.0	68.5	76.1	104.0	190.0
50	49	60.3	2.0	101.0	203.0	65.0	59.0	83.4	112.0	190.0
65	64	76.1	2.0	130.0	254.0	81.0	86.5	95.6	120.0	230.0
80	76	88.9	2.3	155.0	280.2	96.0	92.0	110.0	132.0	260.0
100	100	114.3	2.3	187.0	317.0	124.0	96.5	125.0	160.0	300.0

Dimensions in mm

Accessories



GEMÜ LSF

Inductive dual sensor for quarter turn valves

The GEMÜ LSF inductive dual sensor is suitable for mounting to manually and pneumatically operated quarter turn valves. It is also fitted with an optical position indicator for visual confirmation of position.

Ordering information

Nominal size	Item no.	Designation
DN8–DN20	88470175	LSFS01Z BV F04
DN25–DN32	88470177	LSFS01Z BV F05
DN40–DN65	88470178	LSFS01Z BV F07
DN80–DN100	88470181	LSFS01Z BV F10



GEMÜ LSC

Limit switch box for quarter turn actuators

The GEMÜ LSC limit switch box is suitable for mounting to manually and pneumatically operated quarter turn valves. It is also fitted with an optical position indicator for visual confirmation of position.

Ordering information

Nominal size	Item no.	Designation
DN8–DN20	88494998	LSCS01Z BV F04
DN25–DN32	88495013	LSCS01Z BV F05
DN40–DN65	88495019	LSCS01Z BV F07
DN80–DN100	88495024	LSCS01Z BV F10

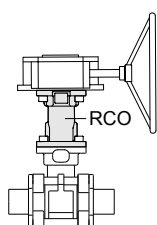

GEMÜ RCO

Shaft extension

The RCO shaft extension for quarter turn valves is a distance piece between manually, pneumatically or electrically operated valves. This means that valves can be protected from flooding or better access for operation of the valve can be ensured (also for manual override). The RCOS is made from steel and the RCOV is made from stainless steel.

Ordering information

See data sheet



GEMÜ Gebr. Müller Apparatebau GmbH & Co. KG
Fritz-Müller-Straße 6-8, 74653 Ingelfingen-Criesbach, Germany
Phone +49 (0)7940 123-0 · info@gemu.de
www.gemu-group.com