

## Ball Valve, Metal

### Construction

The GEMÜ 762 manually operated one-piece 2/2-way stainless steel ball valve with top flange has a plastic sleeved lever.

### Features

- Suitable for inert and corrosive\* liquid and gaseous media and steam
- Suitable for vacuum applications
- The GEMÜ 762 ball valves comply with the safety requirements of Annex I of the European Pressure Equipment Directive 2014/68/UE (PED) for fluids of group 1 and 2
- ATEX version on request

### Advantages

- High flow capability
- Compact design
- Full-flow bore
- Lockable and non-twisting lever
- Pneumatic or motorized actuator can be easily retrofitted



\* see information on working medium on page 2

### Sectional drawing

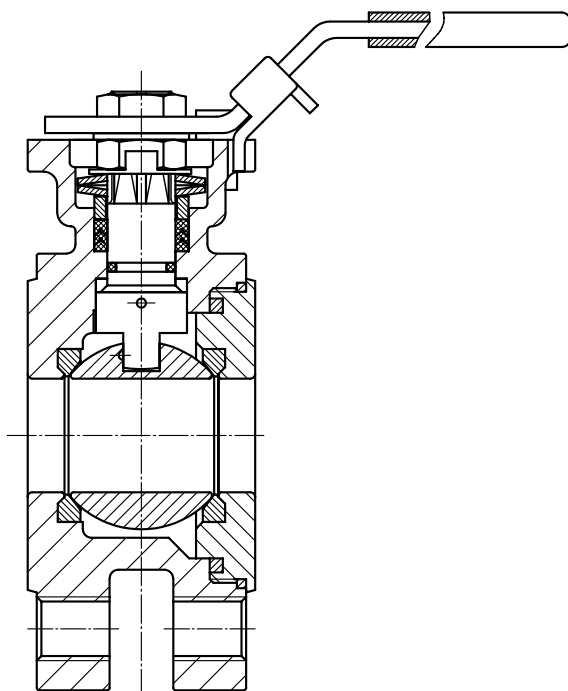

## Technical data

### Working medium

Corrosive, inert, gaseous and liquid media and steam which have no negative impact on the physical and chemical properties of the body and seal materials.

Maximum permissible pressure of working medium see diagram (for water and non-hazardous media to which the body material is resistant)

Maximum permissible operating temperature 180 °C

Ambient temperature -20 ... 60 °C

### Leakage rate

Leakage rate to ANSI FCI70 – B16.104

Leakage rate A to EN12266, 6bar air

Nominal size	NPS	Torque	Kv values	Weight
DN		[Nm]	[m <sup>3</sup> /h]	[kg]
15	1/2"	5	12.8	1.30
20	3/4"	7	29.1	1.96
25	1"	16	47.8	2.80
32	1 1/4"	18	72.6	4.15
40	1 1/2"	29	106.8	5.25
50	2"	36	213.7	6.66
65	2 1/2"	60	273.3	11.88
80	3"	74	495.3	14.90
100	4"	90	871.1	20.38

### Working pressure - Temperature

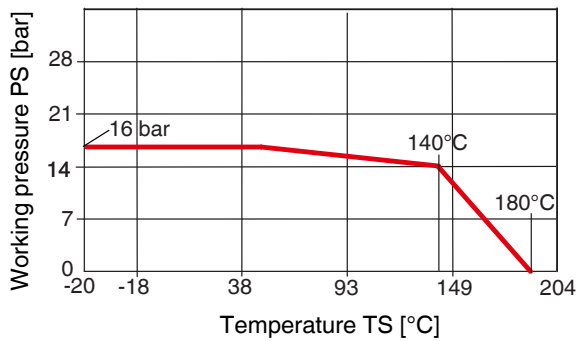

Relief bore hole

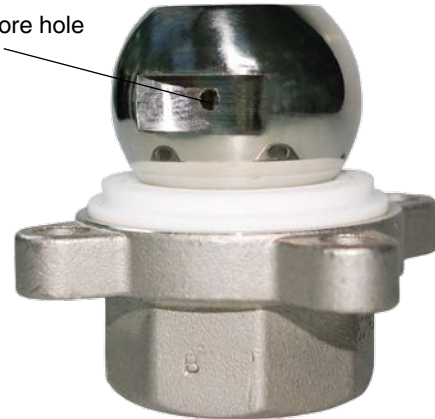

## Order data

Body configuration	Code
2/2-way	D

Seal material	Code
Seat: PTFE	5
TFM™ 1600, (FDA-compliant)	5T

Connection	Code
Flanges ANSI class 125/150 RF	46
Flanges EN 1092 / PN16 / Form B	68

Control function	Code
Manually operated / lockable	L

Valve body material	Code
1.4408 Investment casting (body)	37
1.4401 Ball	

Order example	762	15	D	68	37	5	L
Type	762						
Nominal size		15					
Body configuration (code)			D				
Connection (code)				68			
Valve body material (code)					37		
Seal material (code)						5	
Control function (code)							L

**Body dimensions [mm]**

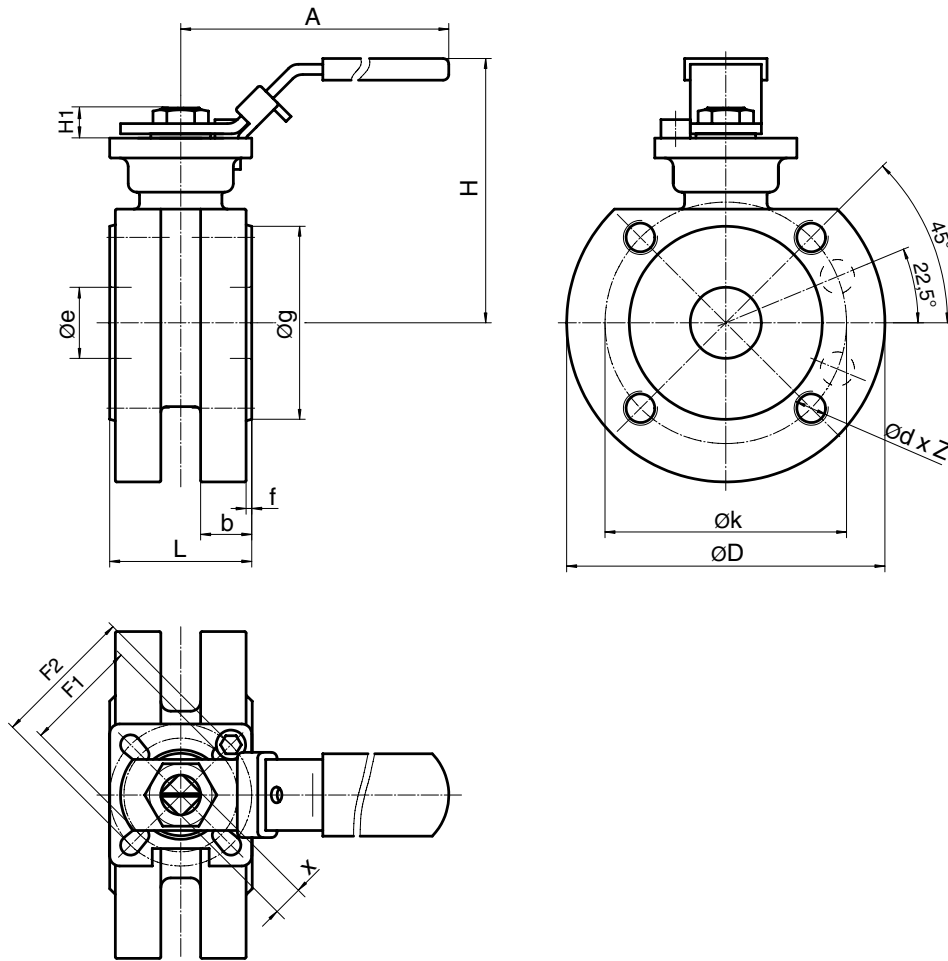

**Flanges ANSI class 125/150 RF, connection code 46**

DN	H	L	$\varnothing D$	$\varnothing e$	$\varnothing d$	Z	$\varnothing k$	$\varnothing g$	f	b	A	x	H1	F1		F2		
15	85	40.8	88.9	15	1/2-13UNC	4	60.5	35.1	1.6	11.2	139	9	7.0	F03	36	$\varnothing 6 \times 4$	F04	$\varnothing 6 \times 4$
20	90	44.0	98.6	20	1/2-13UNC	4	69.9	42.9	1.6	11.2	139	9	8.0	F03	36	$\varnothing 6 \times 4$	F04	$\varnothing 6 \times 4$
25	104	50.0	108.0	25	1/2-13UNC	4	79.2	64.0	1.6	11.2	165	11	12.0	F04	42	$\varnothing 6 \times 4$	F05	$\varnothing 7 \times 4$
32	116	60.0	117.3	32	1/2-13UNC	4	88.9	63.5	1.6	12.7	165	11	11.3	F04	42	$\varnothing 6 \times 4$	F05	$\varnothing 7 \times 4$
40	135	65.0	127.0	38	1/2-13UNC	4	98.6	73.2	1.6	14.3	215	14	15.5	F05	50	$\varnothing 7 \times 4$	F07	$\varnothing 9 \times 4$
50	142	80.0	152.4	50	5/8-11UNC	4	120.7	91.9	1.6	15.9	215	14	16.0	F05	50	$\varnothing 7 \times 4$	F07	$\varnothing 9 \times 4$
65	168	110.0	177.8	65	5/8-11UNC	4	139.7	104.6	1.6	17.6	263	17	15.8	F07	70	$\varnothing 9 \times 4$	F10	$\varnothing 11 \times 4$
80	178	120.0	190.5	80	5/8-11UNC	4	152.4	127.0	1.6	19.0	313	17	16.0	F07	70	$\varnothing 9 \times 4$	F10	$\varnothing 11 \times 4$
100	190	150.0	228.6	100	5/8-11UNC	8	190.5	157.2	1.6	23.9	344	17	17.8	F07	70	$\varnothing 9 \times 4$	F10	$\varnothing 11 \times 4$

**Body dimensions [mm]**

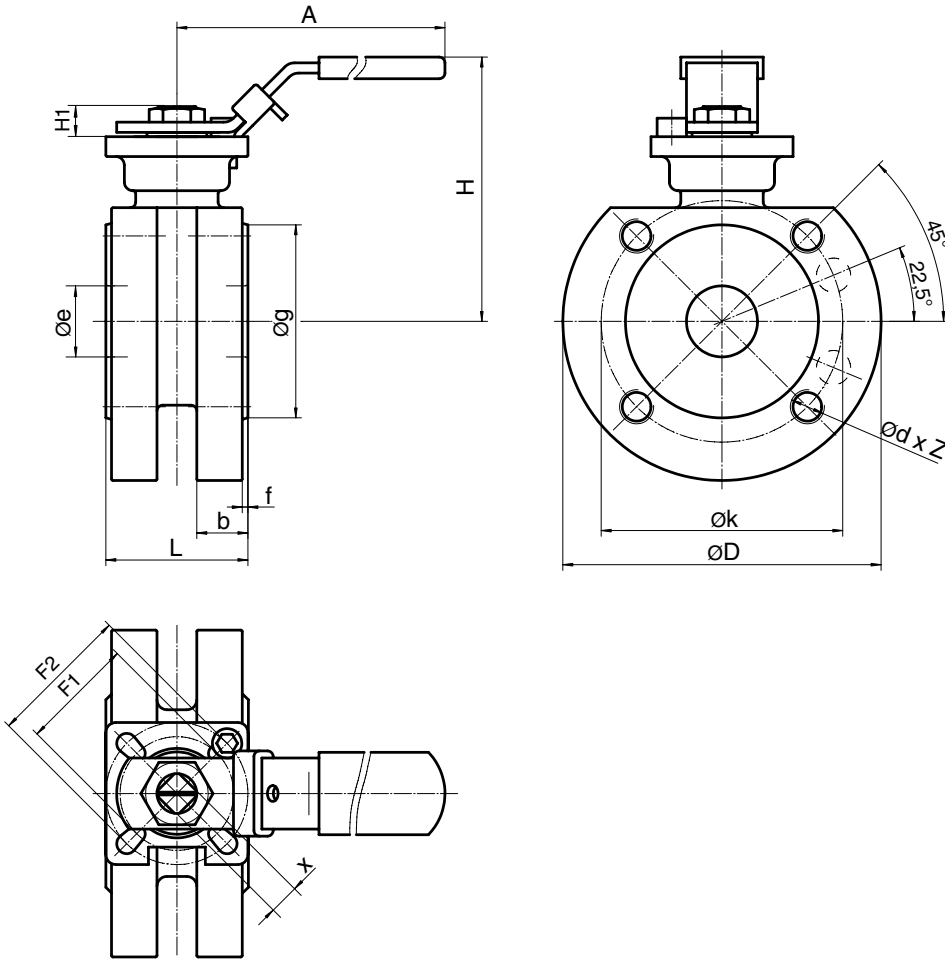

**Flanges EN 1092 / PN16 / Form B, connection code 68**

DN	H	L	øD	øe	ød	Z	øk	øg	f	b	A	x	H1	F1			F2	
15	85	41	81	15	M12	4	65	45	2	16	139	9	7.0	F03	36	ø6 x 4	F04	ø6 x 4
20	90	44	99	20	M12	4	75	58	2	18	139	9	8.0	F03	36	ø6 x 4	F04	ø6 x 4
25	104	50	115	25	M12	4	85	68	2	18	165	11	12.0	F04	42	ø6 x 4	F05	ø7 x 4
32	116	60	140	32	M16	4	100	78	2	18	165	11	11.3	F04	42	ø6 x 4	F05	ø7 x 4
40	135	65	150	38	M16	4	110	88	3	18	215	14	15.5	F05	50	ø7 x 4	F07	ø9 x 4
50	142	80	165	50	M16	4	125	102	3	20	215	14	16.0	F05	50	ø7 x 4	F07	ø9 x 4
65	168	110	185	65	M16	4	145	122	3	22	263	17	15.8	F07	70	ø9 x 4	F10	ø11 x 4
80	178	120	200	80	M16	8	160	138	3	24	313	17	16.0	F07	70	ø9 x 4	F10	ø11 x 4
100	190	150	220	100	M16	8	180	158	3	24	344	17	17.8	F07	70	ø9 x 4	F10	ø11 x 4

For further ball valves and other products, please see our Product Range catalogue and Price List. Contact GEMÜ.

**GEMÜ®** VALVES, MEASUREMENT AND CONTROL SYSTEMS

