

GEMÜ 717

Manually operated ball valve



Features

- High flow rates
- Low weight
- Choice of various body materials and connection types
- Union nut with integrated spin-lock
- 2/2 and 3/2-way versions available
- Optionally available with control ball

Description

The GEMÜ 717 2/2 or 3/2-way plastic ball valve has an ergonomically designed hand lever and is manually operated. The seat seal is made from PTFE and the O-ring seals can be made from either EPDM or FKM.

Technical specifications

- **Media temperature:** -20 to 100 °C
- **Ambient temperature:** -10 to 50 °C
- **Operating pressure :** 0 to 16 bar
- **Nominal sizes:** DN 10 to 100
- **Body configurations:** 2/2-way body | Multi-port body
- **Connection types:** Flange | Solvent cement socket | Spigot | Threaded connection | Union end
- **Connection standards:** ANSI | BS | DIN | EN | ISO | JIS | NPT
- **Body materials:** ABS | PP-H, grey | PVC-C, chlorinated | PVC-U, grey | PVDF
- **Seal materials:** EPDM | FFKM | FKM
- **Conformities:** EAC

Technical data depends on the respective configuration



Product line



GEMÜ 710



GEMÜ 717



GEMÜ 723

Operation

Manual	-	●	-
Pneumatic	●	-	-
Motorized	-	-	●
Nominal sizes	DN 10 to 100	DN 10 to 100	DN 10 to 100
Media temperature *	-20 to 100 °C	-20 to 100 °C	-20 to 100 °C
Operating pressure *	0 to 16 bar	0 to 16 bar	0 to 16 bar
Connection types			
Flange	●	●	●
Solvent cement socket	●	●	●
Spigot	●	●	●
Threaded connection	●	●	●
Union end	●	●	●

* depending on version and/or operating parameters

Product description



Item	Name	Materials
1	Ball valve body	PVC-U, PVC-C, ABS, PP-H or PVDF
2	Pipe connections	PVC-U, PVC-C, ABS, PP-H or PVDF
3	Anti-twist protection	POM
4	Hand lever	HIPVC
	Ball valve seals	FPM, EPDM, FFKM
	Ball valve seat seals	PTFE

Port positions



T-port

	CLOSED end position	OPEN end position	Condition as supplied to customer OPEN
Delivery condition			
Code T			
Optional port positions, can be user adjusted			
Code 2			
Code 3			
Code 4			

L-port

	CLOSED end position	OPEN end position	Condition as supplied to customer OPEN
Delivery condition			
Code L			
Optional port positions, can be user adjusted			
Code 6			

Control ball

	Control ball	Scale
Code R		

For 0°- 90° control range, linear control characteristic between port position and percentage flow rate.

NOTE: Ball configuration (R) cannot be retrofitted to standard 2/2-way bodies at a later date.

Availability

2/2-way body (code D)

DN	Connection type code ¹⁾								
	2	4	33	39	3M	3T	78*	7R	7R
	Material code ²⁾								
	1, 2, 4, 5, 20	1, 2, 5, 20	1, 4	1, 2, 5, 20	1, 2	1	1, 5, 20	1	4, 5
10	X	-	X	-	-	-	-	-	-
15	X	X	X	X	X	X	X	X	X
20	X	X	X	X	X	X	X	X	X
25	X	X	X	X	X	X	X	X	X
32	X	X	X	X	X	X	X	X	X
40	X	X	X	X	X	X	X	X	X
50	X	X	X	X	X	X	X	X	X
65	X	X	X	X	X	X	X	X	-
80	X	X	X	X	X	X	X	X	-
100	X	X	X	X	X	X	X	X	-

* Inserts according to valve body material,
special version: PE insert, design code 1187

Control ball only available for ball valves in PVC-U (code 1), PVDF (code 20) and PP-H (code 5) in nominal sizes DN 10 to 50.

1) Connection type

Code 2: Union end with insert (solvent cement or weld socket) - DIN

Code 4: Union end with flange EN 1092, PN 10, form B, face-to-face dimension FTF EN 558 series 1, ISO 5752, basic series 1

Code 33: Union end with inch insert - BS (socket)

Code 39: Union end with flange ANSI Class 125/150 RF

Code 3M: Union end with inch insert – ASTM (socket)

Code 3T: Union end with JIS insert (socket)

Code 78: Union end with insert (for IR butt welding) - DIN

Code 7R: Union end with insert (Rp threaded socket) - DIN

2) Ball valve material

Code 1: PVC-U, grey

Code 2: PVC-C

Code 4: ABS

Code 5: PP-H, grey

Code 20: PVDF

Multi-port design (code M)

DN	Connection type code ¹⁾							
	2	4	33	39	3M	3T	78*	7R
	Material code ²⁾							
	1, 2, 5	1, 5	1	1	1, 2	1	1, 5	1, 5
10	X	-	-	-	-	-	-	-
15	X	X	X	X	X	X	X	X
20	X	X	X	X	X	X	X	X
25	X	X	X	X	X	X	X	X
32	X	X	X	X	X	X	X	X
40	X	X	X	X	X	X	X	X
50	X	X	X	X	X	X	X	X
65	-	-	-	-	-	-	-	-
80	-	-	-	-	-	-	-	-
100	-	-	-	-	-	-	-	-

* Inserts according to valve body material,
special version: PE insert, design code 1187

1) **Connection type**

Code 2: Union end with insert (solvent cement or weld socket) - DIN

Code 4: Union end with flange EN 1092, PN 10, form B, face-to-face dimension FTF EN 558 series 1, ISO 5752, basic series 1

Code 33: Union end with inch insert - BS (socket)

Code 39: Union end with flange ANSI Class 125/150 RF

Code 3M: Union end with inch insert – ASTM (socket)

Code 3T: Union end with JIS insert (socket)

Code 78: Union end with insert (for IR butt welding) - DIN

Code 7R: Union end with insert (Rp threaded socket) - DIN

2) **Ball valve material**

Code 1: PVC-U, grey

Code 2: PVC-C

Code 5: PP-H, grey

Order data

The order data provide an overview of standard configurations.

Please check the availability before ordering. Other configurations available on request.

Order codes

1 Type	Code
Ball valve, plastic, manually operated	717

2 DN	Code
DN 10	10
DN 15	15
DN 20	20
DN 25	25
DN 32	32
DN 40	40
DN 50	50
DN 65	65
DN 80	80
DN 100	100

3 Body configuration	Code
2/2-way body	D
Multi-port version	M

4 Connection type	Code
Union end with insert (solvent cement or weld socket) - DIN	2
Union end with flange EN 1092, PN 10, form B, face-to-face dimension FTF EN 558 series 1, ISO 5752, basic series 1	4
Union end with inch insert - BS (socket)	33
Union end with flange ANSI Class 125/150 RF	39
Union end with inch insert – ASTM (socket)	3M
Union end with JIS insert (socket)	3T
Union end with insert (for IR butt welding) - DIN	78
Union end with insert (Rp threaded socket) - DIN	7R

5 Ball valve material	Code
PVC-U, grey	1
PVC-C	2
PVDF	20
ABS	4
PP-H, grey	5

6 Seal material	Code
FKM	4
EPDM	14
FFKM	F5

7 Control function	Code
Manually operated	0

8 Ball config./port position	Code
2/2-way body	
R ball (control ball) for 0°- 90° control range linear control characteristic between port position and percentage flow rate	R
Multi-port version	
L-port, standard end position "Open", connection 2 and 3 open, L-port, standard end position "Closed", connection 1 and 3 open	L
T-port, standard end position "Open", connection 1, 2 and 3 open, T-port, standard end position "Closed", connection 1 and 3 open	T
T-port, end position "Open", connection 1 and 3 open, T-port, end position "Closed", connection 1 and 2 open	2
T-port, end position "Open", connection 1 and 2 open, T-port, end position "Closed", connection 2 and 3 open	3
T-port, end position "Open", connection 2 and 3 open, T-port, end position "Closed", connection 1, 2 and 3 open	4
L-port, end position "Open", connection 1 and 3 open, L-port, end position "Closed", connection 1 open	6
9 Type of design	Code
Without	
Insert in PE	1187

Order example

Order option	Code	Description
1 Type	717	Ball valve, plastic, manually operated
2 DN	15	DN 15
3 Body configuration	M	Multi-port version
4 Connection type	33	Union end with inch insert - BS (socket)
5 Ball valve material	1	PVC-U, grey
6 Seal material	14	EPDM
7 Control function	0	Manually operated
8 Ball config./port position	L	L-port, standard end position "Open", connection 2 and 3 open, L-port, standard end position "Closed", connection 1 and 3 open
9 Type of design		Without

Technical data

Medium

Working medium: Corrosive, inert, gaseous and liquid media and steam which have no negative impact on the physical and chemical properties of the body and seal material.

Temperature

Media temperature: see Pressure / temperature diagram

Seal material: FPM: -15 – 210 °C
EPDM: -20 – 95 °C

Ambient temperature: Valve body ABS: -20 to 60 °C
Valve body PP-H: 5 to 60 °C
Valve body PVC-U, PVC-C: 10 to 50 °C
Valve body PVDF: -5 to 50 °C

Pressure

Operating pressure: Pressure / temperature diagram

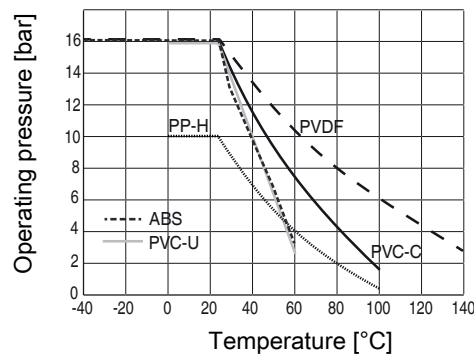

Data for extended temperature ranges on request. Please note that the ambient temperature and media temperature generate a combined temperature at the valve body which must not exceed the above values.

Kv values:

DN	Body configuration						
	2/2-way		Multi-port (code M)				
	(code D)	(code R)	T-port	T-port	T-port	T-port	L-port
10	4.8	4.98	2.2	1.5	2.4	4.7	2.9
15	12.0	5.28	3.3	2.1	3.9	11.7	4.4
20	23.1	8.10	8.1	5.7	8.7	22.8	9.0
25	46.2	15.36	12.3	8.4	14.7	45.6	15.9
32	66.0	28.68	23.4	16.2	27.6	63.0	28.5
40	105.0	35.52	28.5	19.8	36.0	102.0	37.2
50	204.0	64.08	54.0	37.2	72.0	192.0	73.2
65	315.0	-	-	-	-	-	-
80	426.0	-	-	-	-	-	-
100	570.0	-	-	-	-	-	-

Kv values in m³/h

Control diagram: with control ball (code R)

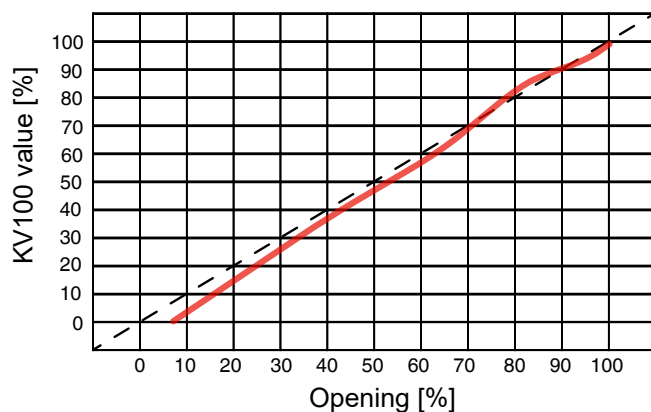

For 0°- 90° control range, linear control characteristic between port position and percentage flow rate.

NOTE: Ball configuration (R) cannot be retrofitted to standard 2/2-way bodies at a later date.

Mechanical data

Torques:

DN	2/2-way code D				Multi-port code M		
	PN 6	PN 10	PN 16		PN 10	PN 16	
	Material code ¹⁾						
	1, 2, 4, 5, 20	5	1, 2, 20	4	1, 2	5	1, 2
10	-	2.4	3.6	3.0	-	-	-
15	-	2.4	3.6	3.0	2.4	2.4	3.6
20	-	3.6	4.0	4.0	3.6	3.6	4.8
25	-	4.8	6.0	6.0	5.0	5.0	5.4
32	-	7.2	7.2	7.2	7.2	7.2	11.5
40	-	8.6	10.0	10.0	9.6	10.0	14.8
50	-	12.4	16.0	16.0	14.8	14.8	23.3
65	20.0	25.0	30.0	30.0	-	-	-
80	25.0	35.0	45.0	45.0	-	-	-
100	40.0	55.0	65.0	65.0	-	-	-

Torques in Nm

- 1) **Ball valve material**
- Code 1: PVC-U, grey
- Code 2: PVC-C
- Code 4: ABS
- Code 5: PP-H, grey
- Code 20: PVDF

Dimensions

2/2-way body

Valve body material PVC-U (code 1), body configuration D

Socket

connection type code 2, 33, 3M, 3T, 7R

Flange

connection type code 4, 39

Butt weld spigot

connection type code 2 (PVDF), 78, 78*

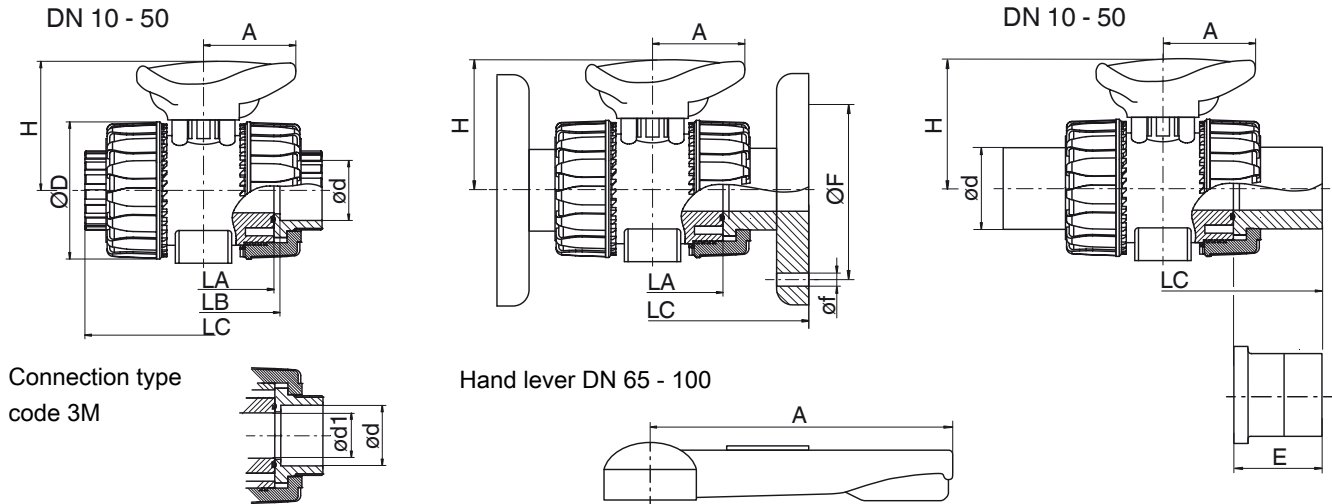

DN	Connection type code ¹⁾														
	d	ød	ØD	A	H	LA	LC			øf		ØF		E	
15	1/2"	20.0	54.0	40.0	54.0	65.0	130.0	143.0	175.0	14.0	15.9	65.0	60.3	55.0	
20	3/4"	25.0	65.0	49.0	65.0	70.0	150.0	172.0	210.0	14.0	15.9	75.0	69.9	70.0	
25	1"	32.0	73.0	49.0	69.5	78.0	160.0	187.0	226.0	14.0	15.9	85.0	79.4	74.0	
32	1 ¼"	40.0	86.0	64.0	82.5	88.0	180.0	190.0	243.0	18.0	15.9	100.0	88.9	78.0	
40	1 ½"	50.0	98.0	64.0	89.0	93.0	200.0	212.0	261.0	18.0	15.9	110.0	98.4	84.0	
50	2"	63.0	122.0	76.0	108.0	111.0	230.0	234.0	293.0	18.0	19.1	125.0	120.7	91.0	
65	2 ½"	75.0	164.0	175.0	164.0	133.0	290.0	290.0	356.0	17.0	18.0	145.0	139.7	111.0	
80	3"	90.0	203.0	272.0	177.0	149.0	310.0	310.0	390.0	17.0	18.0	160.0	152.4	118.0	
100	4"	110.0	238.0	330.0	195.0	167.0	350.0	350.0	431.0	17.0	18.0	180.0	190.5	132.0	

Dimensions in mm

* Inserts according to valve body material, special version: PE insert, design code 1187

1) **Connection type**

- Code 4: Union end with flange EN 1092, PN 10, form B, face-to-face dimension FTF EN 558 series 1, ISO 5752, basic series 1
- Code 39: Union end with flange ANSI Class 125/150 RF
- Code 78: Union end with insert (for IR butt welding) - DIN

Valve body material PVC-U (code 1), body configuration D

Socket
connection type code 2, 33, 3M, 3T, 7R

Flange
connection type code 4, 39

Butt weld spigot
connection type code 2 (PVDF), 78, 78*

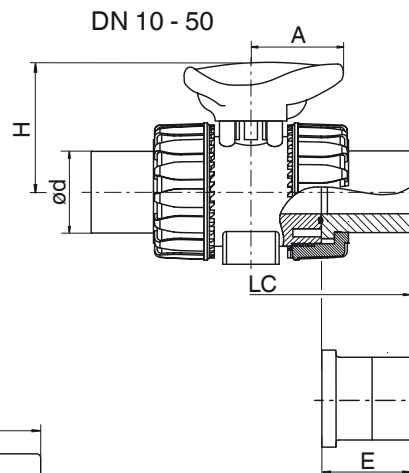
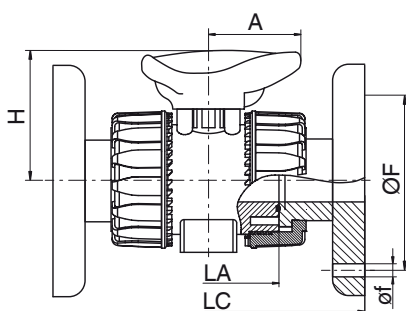
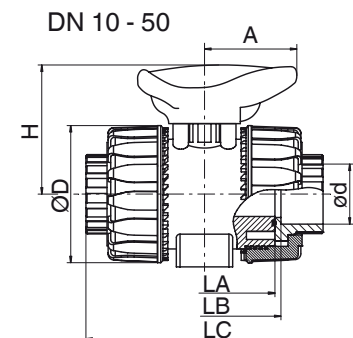

Connection type
code 3M

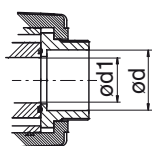

Hand lever DN 65 - 100

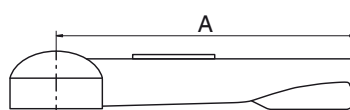

DN	Connection type code ¹⁾																
	d	ød	ØD	A	LA	H	ød1	LB					LC				
10	3/8"	16.0	54.0	40.0	65.0	54.0	21.5	75.0	74.0	-	-	-	103.0	103.0	-	-	-
15	1/2"	20.0	54.0	40.0	65.0	54.0	26.9	71.0	70.0	72.0	71.0	80.0	103.0	103.0	117.0	131.0	110.0
20	3/4"	25.0	65.0	49.0	70.0	65.0	33.7	77.0	77.0	78.0	77.0	83.5	115.0	115.0	129.0	147.0	116.0
25	1"	32.0	73.0	49.0	78.0	69.5	42.4	84.0	83.0	84.6	84.0	96.0	128.0	128.0	142.0	164.0	134.0
32	1 ¼"	40.0	86.0	64.0	88.0	82.5	48.4	94.0	94.0	98.0	94.0	110.0	146.0	146.0	162.0	182.0	153.0
40	1 ½"	50.0	98.0	64.0	93.0	89.0	60.5	102.0	104.0	102.0	102.0	113.0	164.0	164.0	172.0	212.0	156.0
50	2"	63.0	122.0	76.0	111.0	108.0	-	123.0	127.0	122.0	122.0	134.0	199.0	199.0	199.0	248.0	186.0
65	2 ½"	75.0	164.0	175.0	133.0	164.0	-	147.0	147.0	146.0	145.0	174.0	235.0	235.0	235.0	267.0	235.0
80	3"	90.0	203.0	272.0	149.0	177.0	-	168.0	168.0	174.0	165.0	203.0	270.0	270.0	270.0	294.0	270.0
100	4"	110.0	238.0	330.0	167.0	195.0	-	186.0	182.0	193.0	202.0	229.0	308.0	308.0	308.0	370.0	308.0

Dimensions in mm

1) **Connection type**

- Code 2: Union end with insert (solvent cement or weld socket) - DIN
- Code 33: Union end with inch insert - BS (socket)
- Code 3M: Union end with inch insert - ASTM (socket)
- Code 3T: Union end with JIS insert (socket)
- Code 7R: Union end with insert (Rp threaded socket) - DIN

Valve body material PVC-C (code 2), body configuration D

Socket
connection type code 2, 33, 3M, 3T, 7R

Flange
connection type code 4, 39

Butt weld spigot
connection type code 2 (PVDF), 78, 78*

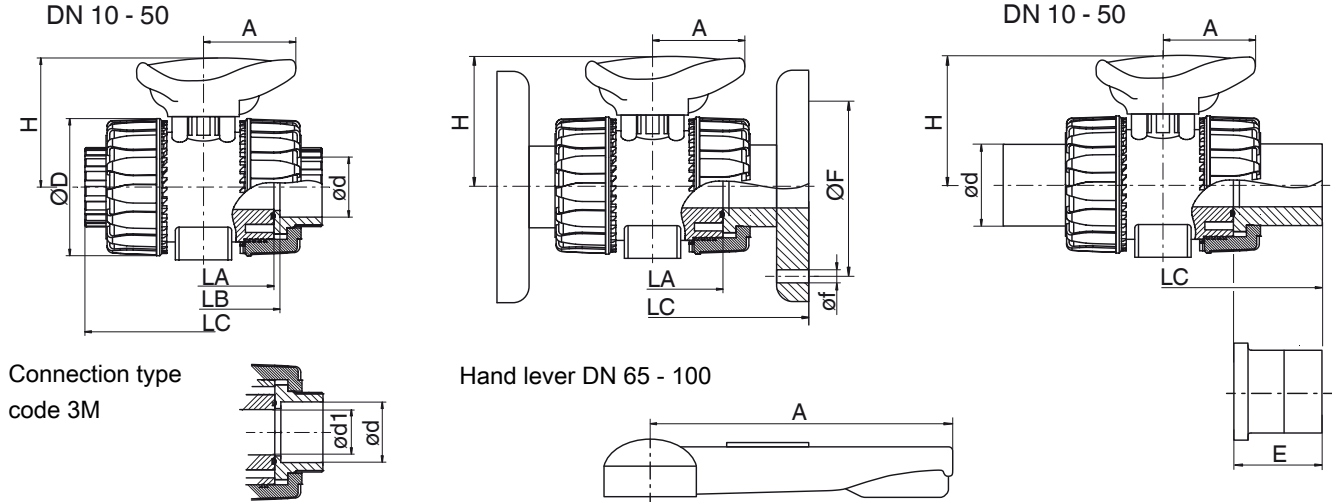

DN	Connection type code ¹⁾											2		3M		2		4		39		3M		4		39		4		39	
	d	ød	øD	A	H	LA	LB	LC	LC	LC	LC	LC	LC	LC	LC	LC	LC	LC	LC	LC	LC	LC	LC	LC	LC	LC	LC	LC	LC	LC	
10	3/8"	16.0	54.0	40.0	54.0	65.0	75.0	-	103.0	-	-	-	-	-	-	-	-	-	-	-	-	-	-	-	-	-	-	-	-	-	
15	1/2"	20.0	54.0	40.0	54.0	65.0	71.0	72.0	103.0	130.0	143.0	117.0	14.0	15.9	65.0	60.3															
20	3/4"	25.0	65.0	49.0	65.0	70.0	77.0	78.0	115.0	150.0	172.0	129.0	14.0	15.9	75.0	69.9															
25	1"	32.0	73.0	49.0	69.5	78.0	84.0	84.6	128.0	160.0	187.0	142.0	14.0	15.9	85.0	79.4															
32	1 1/4"	40.0	86.0	64.0	82.5	88.0	94.0	98.0	146.0	180.0	190.0	162.0	18.0	15.9	100.0	88.9															
40	1 1/2"	50.0	98.0	64.0	89.0	93.0	102.0	102.0	164.0	200.0	212.0	172.0	18.0	15.9	110.0	98.4															
50	2"	63.0	122.0	76.0	108.0	111.0	123.0	122.6	199.0	230.0	234.0	199.0	18.0	19.1	125.0	120.7															
65	2 1/2"	75.0	164.0	175.0	164.0	133.0	147.0	146.0	235.0	290.0	290.0	235.0	17.0	18.0	145.0	139.7															
80	3"	90.0	203.0	272.0	177.0	149.0	168.0	174.0	270.0	310.0	310.0	270.0	17.0	18.0	160.0	152.4															
100	4"	110.0	238.0	330.0	195.0	167.0	186.0	193.0	308.0	350.0	350.0	308.0	17.0	18.0	180.0	190.5															

Dimensions in mm

1) **Connection type**

- Code 2: Union end with insert (solvent cement or weld socket) - DIN
- Code 4: Union end with flange EN 1092, PN 10, form B, face-to-face dimension FTF EN 558 series 1, ISO 5752, basic series 1
- Code 39: Union end with flange ANSI Class 125/150 RF
- Code 3M: Union end with inch insert - ASTM (socket)

Valve body material ABS (code 4), body configuration D

Socket
connection type code 2, 33, 3M, 3T, 7R

Flange
connection type code 4, 39

Butt weld spigot
connection type code 2 (PVDF), 78, 78*

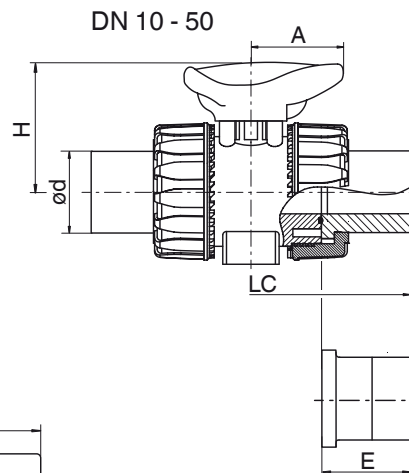
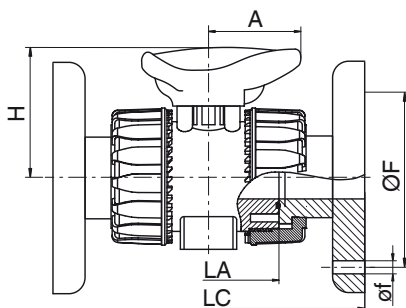
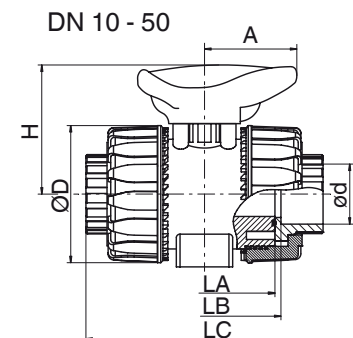

Connection type
code 3M

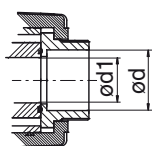

Hand lever DN 65 - 100

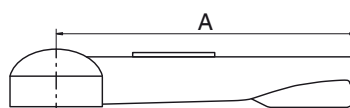

DN	Connection type code ¹⁾						2	7R	33	2, 33	7R
	d	ød	øD	A	LA	H	LB		LC		
10	3/8"	15.0	55.0	40.0	65.0	49.0	75.0	-	75.0	103.0	-
15	1/2"	20.0	55.0	40.0	65.0	49.0	71.0	80.0	71.0	103.0	110.0
20	3/4"	25.0	66.0	49.0	70.0	59.0	77.0	83.4	77.0	115.0	116.0
25	1"	32.0	75.0	49.0	78.0	66.0	84.0	95.8	84.0	128.0	134.0
32	1 1/4"	40.0	87.0	64.0	88.0	75.0	94.0	110.2	94.0	146.0	153.0
40	1 1/2"	50.0	100.0	64.0	93.0	87.0	102.0	113.2	102.0	164.0	156.0
50	2"	63.0	122.0	76.0	111.0	101.0	123.0	134.6	123.0	199.0	186.0
65	2 1/2"	75.0	164.0	175.0	133.0	164.0	147.0	-	147.0	235.0	-
80	3"	90.0	203.0	272.0	149.0	177.0	168.0	-	168.0	270.0	-
100	4"	110.0	238.0	330.0	167.0	195.0	186.0	-	186.0	308.0	-

Dimensions in mm

1) **Connection type**

- Code 2: Union end with insert (solvent cement or weld socket) - DIN
- Code 33: Union end with inch insert - BS (socket)
- Code 7R: Union end with insert (Rp threaded socket) - DIN

Valve body material PP-H (code 5), body configuration D

Socket
connection type code 2, 33, 3M, 3T, 7R

Flange
connection type code 4, 39

Butt weld spigot
connection type code 2 (PVDF), 78, 78*

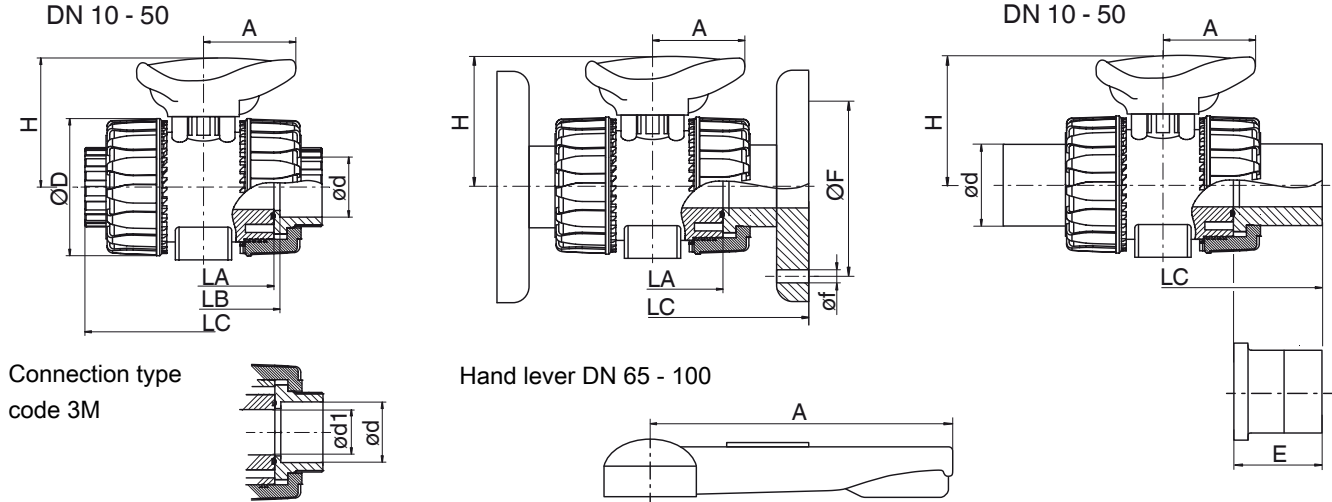

DN	Connection type code ¹⁾																	
	2	7R	2	4	39	78/78 *	7R	78/78 *	4	39	4	39						
	d	ød	øD	A	H	LA	LB	LC		E	øf	ØF						
10	3/8"	16.0	54.0	40.0	-	65.0	75.0	-	102.0	-	-	-	-	-	-	-	-	-
15	1/2"	20.0	54.0	40.0	54.0	65.0	73.0	80.0	102.0	130.0	143.0	175.0	110.0	55.0	14.0	15.9	65.0	60.3
20	3/4"	25.0	65.0	49.0	65.0	70.0	82.0	83.0	114.0	150.0	172.0	210.0	116.0	70.0	14.0	15.9	75.0	69.9
25	1"	32.0	73.0	49.0	69.5	78.0	90.0	96.0	126.0	160.0	187.0	226.0	134.0	77.0	14.0	15.9	85.0	79.4
32	1 1/4"	40.0	86.0	64.0	82.5	88.0	100.0	110.0	141.0	180.0	190.0	243.0	153.0	78.0	18.0	15.9	100.0	88.9
40	1 1/2"	50.0	98.0	64.0	89.0	93.0	117.0	113.0	164.0	200.0	212.0	261.0	156.0	84.0	18.0	15.9	110.0	98.4
50	2"	63.0	122.0	76.0	108.0	111.0	144.0	134.0	199.0	230.0	234.0	293.0	186.0	91.0	18.0	15.9	125.0	120.7
65	2 1/2"	75.0	164.0	175.0	164.0	133.0	153.0	-	213.0	290.0	290.0	356.0	-	111.0	17.0	18.0	145.0	139.7
80	3"	90.0	203.0	272.0	177.0	149.0	173.0	-	239.0	310.0	310.0	390.0	-	118.0	17.0	18.0	160.0	152.4
100	4"	110.0	238.0	330.0	195.0	167.0	199.0	-	268.0	350.0	350.0	431.0	-	132.0	17.0	18.0	180.0	190.5

Dimensions in mm

* Inserts according to valve body material, special version: PE insert, design code 1187

1) **Connection type**

- Code 2: Union end with insert (solvent cement or weld socket) - DIN
- Code 4: Union end with flange EN 1092, PN 10, form B, face-to-face dimension FTF EN 558 series 1, ISO 5752, basic series 1
- Code 39: Union end with flange ANSI Class 125/150 RF
- Code 78: Union end with insert (for IR butt welding) - DIN
- Code 7R: Union end with insert (Rp threaded socket) - DIN

Valve body material PVDF (code 20), body configuration D

Socket
connection type code 2, 33, 3M, 3T, 7R

Flange
connection type code 4, 39

Butt weld spigot
connection type code 2 (PVDF), 78, 78*

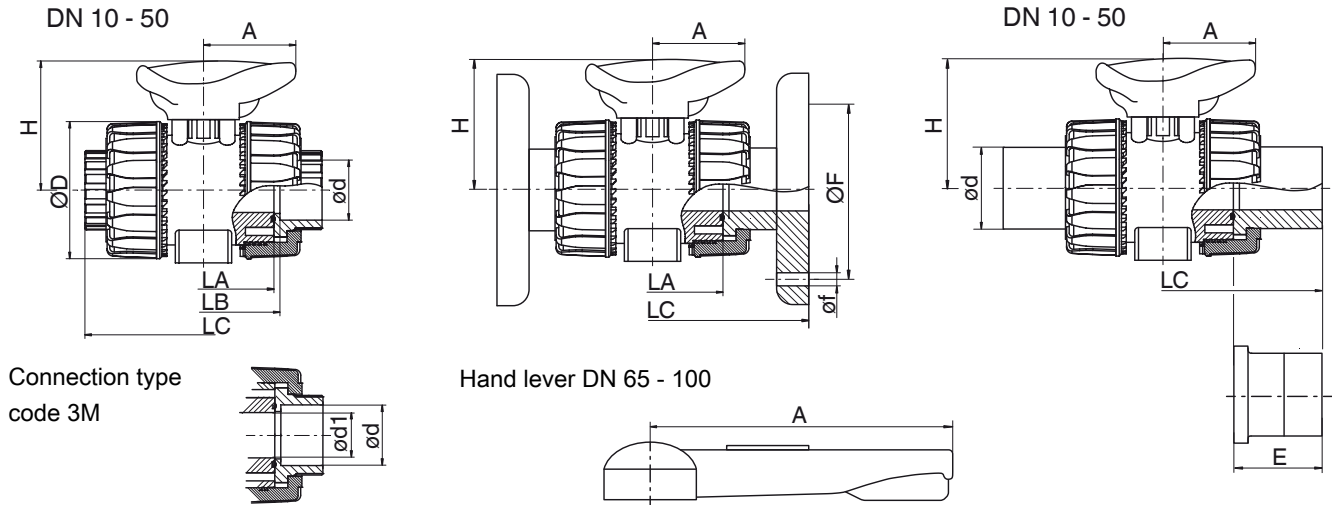

DN	Connection type code ¹⁾														
	d	$\varnothing d$	$\varnothing D$	A	H	LA	LB	LC			$\varnothing f$	$\varnothing F$	E		
10	-	16.0	54.0	40.0	54.0	65.0	74.5	102.0	-	-	-	-	-		
15	1/2"	20.0	54.0	40.0	54.0	65.0	73.0	102.0	130.0	124.0	14.0	15.9	65.0	60.5	30.0
20	3/4"	25.0	65.0	49.0	65.0	70.0	82.0	114.0	150.0	144.0	14.0	15.9	75.0	70.0	37.0
25	1"	32.0	73.0	49.0	69.5	78.0	90.0	126.0	160.0	154.0	14.0	15.9	85.0	79.5	39.5
32	1 1/4"	40.0	86.0	64.0	82.5	88.0	100.0	141.0	180.0	174.0	18.0	15.9	100.0	89.0	44.5
40	1 1/2"	50.0	98.0	64.0	89.0	93.0	117.0	164.0	200.0	194.0	18.0	15.9	110.0	98.5	51.5
50	2"	63.0	122.0	76.0	108.0	111.0	144.0	199.0	230.0	224.0	18.0	19.1	134.0	121.0	58.0
65	2 1/2"	75.0	164.0	175.0	164.0	133.0	147.0	235.0	290.0	355.0	18.0	18.0	145.0	140.0	110.5
80	3"	90.0	203.0	272.0	177.0	149.0	173.0	239.0	310.0	389.0	18.0	18.0	160.0	152.5	118.5
100	4"	110.0	238.0	330.0	195.0	167.0	186.0	308.0	350.0	427.0	18.0	18.0	180.0	190.5	130.5

Dimensions in mm

* Inserts according to valve body material, special version: PE insert, design code 1187

1) **Connection type**

- Code 2: Union end with insert (solvent cement or weld socket) - DIN
- Code 4: Union end with flange EN 1092, PN 10, form B, face-to-face dimension FTF EN 558 series 1, ISO 5752, basic series 1
- Code 39: Union end with flange ANSI Class 125/150 RF
- Code 78: Union end with insert (for IR butt welding) - DIN

Multi-port design

Valve body material PVC-U (code 1), body configuration M

Connection type code 2, 33, 3M, 3T, 7R

Connection type code 78, 78*

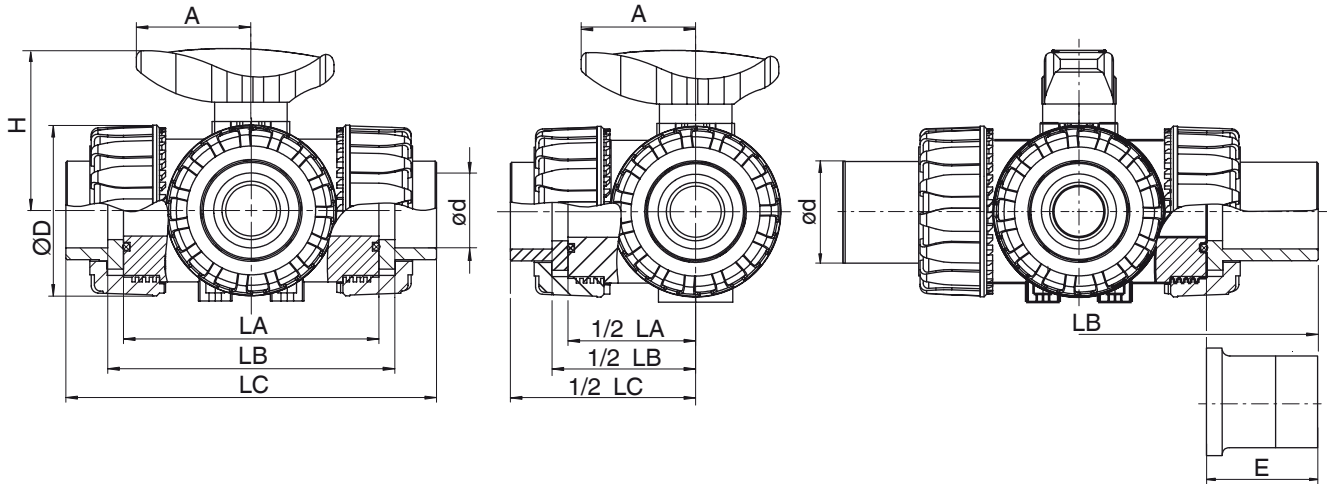

DN	Connection type code ¹⁾						2	33	3M	3T	7R	2, 33	3M	3T	7R	78*	78*
	d	ød	ØD	A	H	LA											
10	3/8"	16.0	54.0	40.0	54.0	80.0	90.0	-	-	-	-	118.0	-	-	-	-	-
15	1/2"	20.0	54.0	40.0	54.0	80.0	86.0	85.0	87.2	86.0	95.0	118.0	132.2	146.0	125.0	190.0	55.0
20	3/4"	25.0	65.0	49.0	65.0	100.0	107.0	106.8	108.2	107.0	114.0	145.0	159.2	177.0	146.0	240.0	70.0
25	1"	32.0	73.0	49.0	69.5	110.0	116.0	115.0	116.6	116.0	129.0	160.0	174.0	196.0	166.0	258.0	74.0
32	1 1/4"	40.0	86.0	64.0	82.5	131.0	136.5	136.6	141.0	137.0	151.0	188.5	205.0	225.0	195.5	287.0	78.0
40	1 1/2"	50.0	98.0	64.0	89.0	148.0	157.0	159.0	157.6	157.2	166.0	219.0	227.6	267.2	211.0	316.0	84.0
50	2"	63.0	122.0	76.0	108.0	179.0	190.5	194.2	190.6	190.0	199.0	266.5	267.0	316.0	253.5	361.0	91.0

Dimensions in mm

* Inserts according to valve body material, special version: PE insert, design code 1187

1) **Connection type**

- Code 2: Union end with insert (solvent cement or weld socket) - DIN
- Code 33: Union end with inch insert - BS (socket)
- Code 3M: Union end with inch insert - ASTM (socket)
- Code 3T: Union end with JIS insert (socket)
- Code 78: Union end with insert (for IR butt welding) - DIN
- Code 7R: Union end with insert (Rp threaded socket) - DIN

Valve body material PVC-C (code 2), body configuration M

Connection type code 2, 33, 3M, 3T, 7R

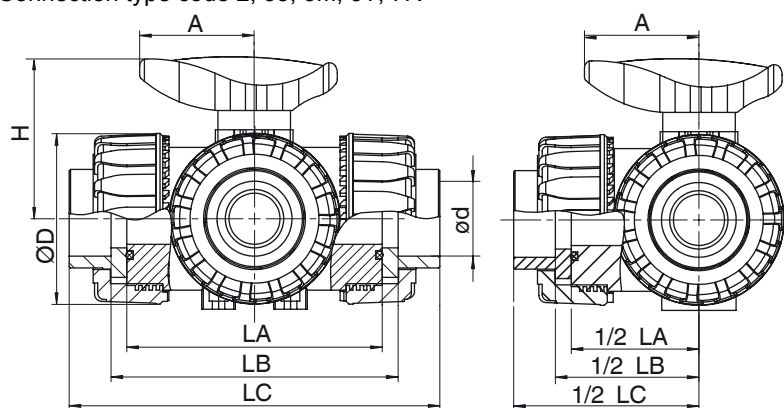

DN	Connection type code ¹⁾						2	3M	2	3M
	d	ød	ØD	A	H	LA	LB	LC	LC	
10	3/8"	16.0	54.0	40.0	54.0	80.0	90.0	-	118.0	-
15	1/2"	20.0	54.0	40.0	54.0	80.0	86.0	87.2	118.0	132.2
20	3/4"	25.0	65.0	49.0	65.0	100.0	107.0	108.2	145.0	159.2
25	1"	32.0	73.0	49.0	69.5	110.0	116.0	116.6	160.0	174.0
32	1 ¼"	40.0	86.0	64.0	82.5	131.0	136.5	141.0	188.5	205.0
40	1 ½"	50.0	98.0	64.0	89.0	148.0	157.0	157.6	219.0	227.6
50	2"	63.0	122.0	76.0	108.0	179.0	190.5	190.6	266.5	267.0

Dimensions in mm

1) **Connection type**

Code 2: Union end with insert (solvent cement or weld socket) - DIN

Code 3M: Union end with inch insert - ASTM (socket)

Valve body material ABS (code 4), body configuration M

Connection type code 2, 33, 3M, 3T, 7R

Connection type code 78, 78*

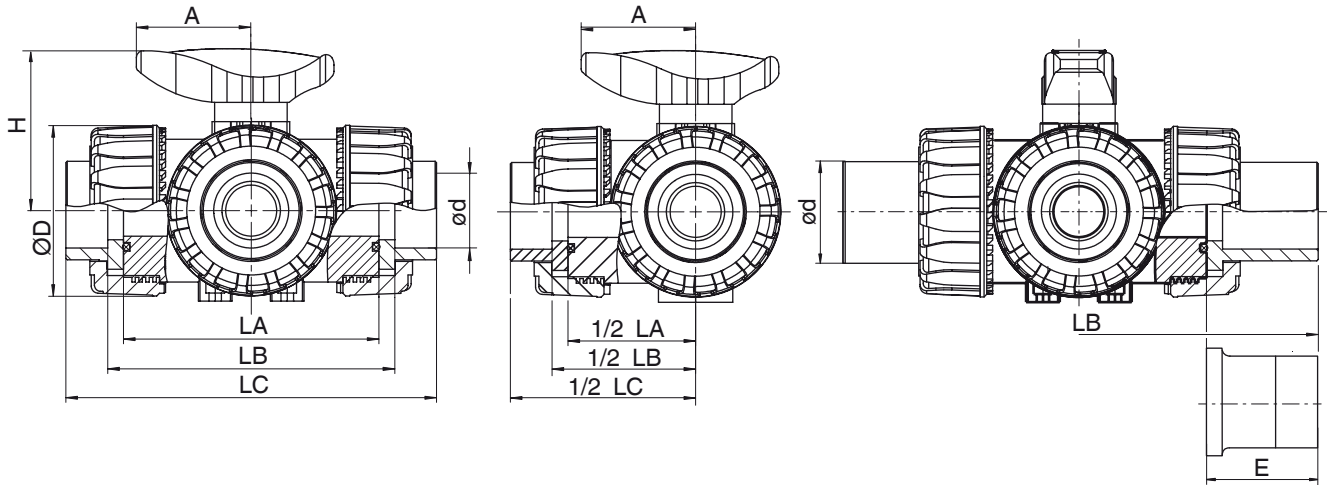

DN	Connection type code 1)						2	33	3M	3T	7R	2, 33	3M	3T	7R	78*	78*
	d	ød	ØD	A	H	LA	LB				LC				E		
10	3/8"	16.0	54.0	40.0	54.0	80.0	90.0	-	-	-	-	118.0	-	-	-	-	-
15	1/2"	20.0	54.0	40.0	54.0	80.0	86.0	85.0	87.2	86.0	95.0	118.0	132.2	146.0	125.0	190.0	55.0
20	3/4"	25.0	65.0	49.0	65.0	100.0	107.0	106.8	108.2	107.0	114.0	145.0	159.2	177.0	146.0	240.0	70.0
25	1"	32.0	73.0	49.0	69.5	110.0	116.0	115.0	116.6	116.0	129.0	160.0	174.0	196.0	166.0	258.0	74.0
32	1 1/4"	40.0	86.0	64.0	82.5	131.0	136.5	136.6	141.0	137.0	151.0	188.5	205.0	225.0	195.5	287.0	78.0
40	1 1/2"	50.0	98.0	64.0	89.0	148.0	157.0	159.0	157.6	157.2	166.0	219.0	227.6	267.2	211.0	316.0	84.0
50	2"	63.0	122.0	76.0	108.0	179.0	190.5	194.2	190.6	190.0	199.0	266.5	267.0	316.0	253.5	361.0	91.0

Dimensions in mm

* Inserts according to valve body material, special version: PE insert, design code 1187

1) Connection type

- Code 2: Union end with insert (solvent cement or weld socket) - DIN
- Code 33: Union end with inch insert - BS (socket)
- Code 3M: Union end with inch insert - ASTM (socket)
- Code 3T: Union end with JIS insert (socket)
- Code 78: Union end with insert (for IR butt welding) - DIN
- Code 7R: Union end with insert (Rp threaded socket) - DIN

Valve body material PP-H (code 5), body configuration M

Connection type code 2, 33, 3M, 3T, 7R

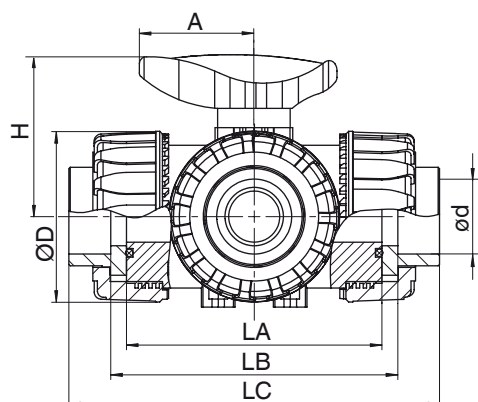

Connection type code 78, 78*

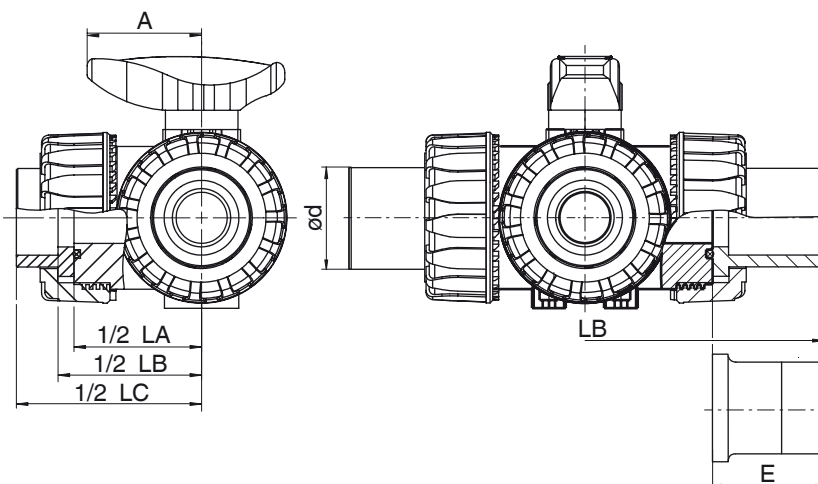

DN	Connection type code ¹⁾						2	7R	2	7R	78, 78*	78, 78*
	d	ød	ØD	A	H	LA	LB 1		LC		E	
15	1/2"	20.0	54.0	40.0	54.0	80.0	88.0	87.0	117.0	117.0	190.0	55.0
20	3/4"	25.0	65.0	49.0	65.0	100.0	112.0	114.0	144.0	143.0	240.0	70.0
25	1"	32.0	69.5	49.0	69.5	110.0	122.0	120.0	158.0	157.0	258.0	74.0
32	1 1/4"	40.0	82.5	64.0	82.5	131.0	142.5	140.0	183.5	184.5	287.0	78.0
40	1 1/2"	50.0	89.0	64.0	89.0	148.0	172.0	172.0	216.0	217.0	316.0	84.0
50	2"	63.0	108.0	76.0	108.0	179.0	211.5	211.0	266.5	265.5	361.0	91.0

Dimensions in mm

* Inserts according to valve body material,
special version: PE insert, design code 1187

1) **Connection type**

Code 2: Union end with insert (solvent cement or weld socket) - DIN

Code 78: Union end with insert (for IR butt welding) - DIN

Code 7R: Union end with insert (Rp threaded socket) - DIN

Accessories

GEMÜ 717 MPL

Mounting plate



Only for 2-way ball valves. The spacer plate kit includes a spacer plate (PP, glass fibre reinforced), screws (stainless steel), threaded inserts (brass). For the nominal sizes DN 65 - 100, the mounting plate is integrated into the ball valve.

Ordering information

Nominal size	Item number	Designation	Order designation
DN 10 - 25	88290237	Threaded insert M4 x 6	717 25MPL
DN 32 - 50	88290238	Threaded insert M6 x 10	717 50MPL



GEMÜ Gebr. Müller Apparatebau GmbH & Co. KG
Fritz-Müller-Straße 6-8, 74653 Ingelfingen-Criesbach, Germany
Phone +49 (0) 7940 1230 · info@gemu.de
www.gemu-group.com