

DF200P Series

Size : 300 x 265.5
Unit : mm

(Duct Fan)

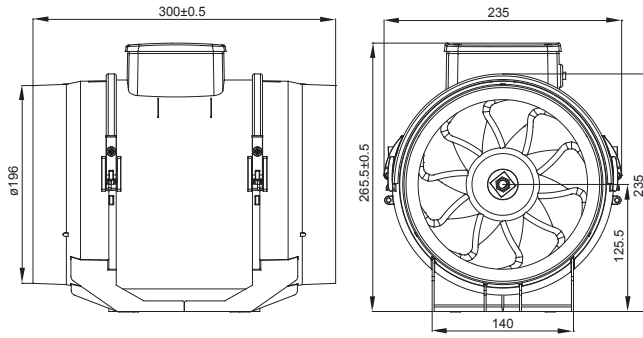
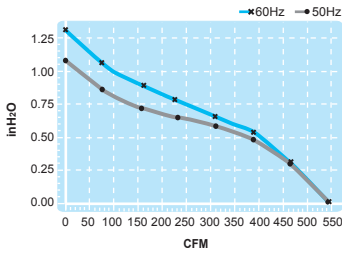

Thermally-Protected



Spec.	Rated Voltage	Frequency	Input Power	Rated Current	Locked Current	Speed	Maximum Air Flow	Maximum Air Flow	Maximum Pressure	Maximum Pressure	Noise	IP	Weight
Model	V	Hz	W	A	A	RPM	m ³ /min.	CFM	mmH ₂ O	InchH ₂ O	dB	Rate	kg
DF200P23-H	230	50	150	0.63	0.95	2100	15.6	550	29	1.14	59	44	4
-L	230	50	125	0.54	0.65	1700	12.5	440	26	1.02	53	44	4

DF150P Series

Size : 294 x 235
2-Speed: High and Low
Unit : mm

(Duct Fan)

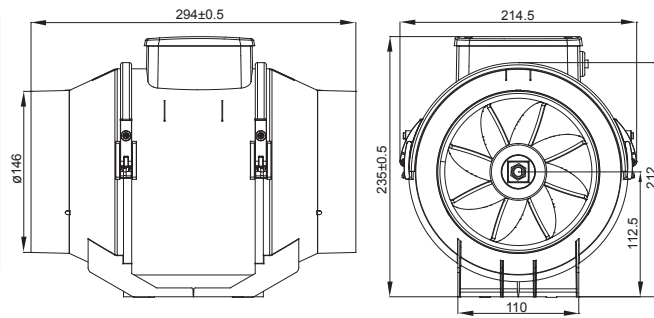
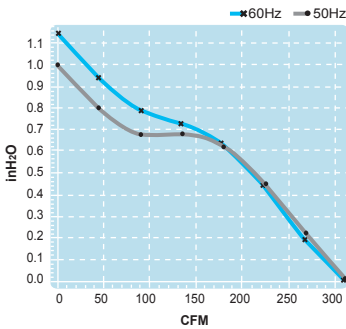

Thermally-Protected



Spec.	Rated Voltage	Frequency	Input Power	Rated Current	Locked Current	Speed	Maximum Air Flow	Maximum Air Flow	Maximum Pressure	Maximum Pressure	Noise	IP	Weight
Model	V	Hz	W	A	A	RPM	m ³ /min.	CFM	mmH ₂ O	InchH ₂ O	dB	Rate	kg
DF150P11-H	115	50	65	0.54	0.67	2000	8.5	300	26	1.02	62	44	2.6
		60	75	0.65	0.68	1900	8.2	290	29	1.14	61	44	2.6
-L	115	50	50	0.43	0.46	1400	5.7	200	19	0.75	53	44	2.6
		60	52	0.46	0.47	1300	5.1	180	17	0.67	50	44	2.6
DF150P23-H	230	50	65	0.27	0.32	2000	8.5	300	26	1.02	62	44	2.6
		60	75	0.32	0.33	1900	8.2	290	29	1.14	61	44	2.6
-L	230	50	50	0.21	0.23	1400	5.7	200	19	0.75	53	44	2.6
		60	52	0.23	0.24	1300	5.1	180	17	0.67	50	44	2.6