

RELY ON EXCELLENCE

H12N

Mechanical seals | Mechanical seals for pumps | Pusher seals

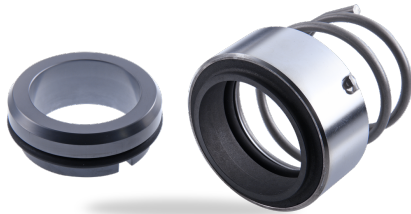

Features

- For stepped shafts
- Single seal
- Balanced
- Dependent of direction of rotation
- Torque transmission via conical spring

Advantages

- High flexibility due to extended selection of materials
- Insensitive to low solids contents
- Short Installation length possible (G16)
- Economical balanced seal
- Seat cooling for hot water applications available (G115)
- No damage of the shaft by set screws

Operating range

Shaft diameter:
d1 = 10 ... 80 mm (0.4" ... 3.125")
Pressure: p1 = 25 bar (363 PSI)
Temperature:
t = -50 °C ... +220 °C (-58 °F ... +430 °F)
Sliding velocity: vg = 15 m/s (50 ft/s)
Axial movement: ±1.0 mm

Materials

Seal face: Carbon graphite antimony impregnated (A)
Seat G9: Silicon carbide (Q1), Special cast CrMo steel (S)

Standards and approvals

- EN 12756

Recommended applications

- Chemical industry
- Pulp and paper industry
- Water and waste water technology
- Low solids content media (H12GN)
- Hot water
- Chemical standard pumps
- Water and sewage pumps

RELY ON EXCELLENCE

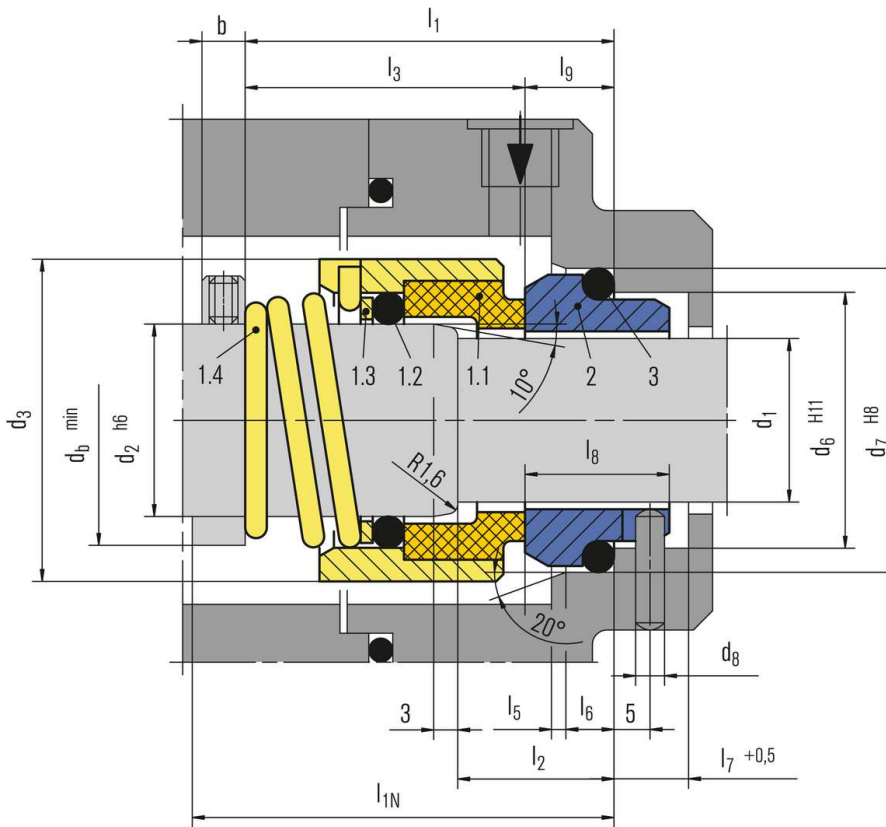

Item Part no. to Description DIN 24250

Item	Part no.	Description
1.1	472/473	Seal face
1.2	412.1	O-Ring
1.3	474	Thrust ring
1.4	478	Righthand spring
1.4	479	Lefthand spring
2	475	Seat (G9)
3	412.2	O-Ring

RELY ON EXCELLENCE

Seat alternatives

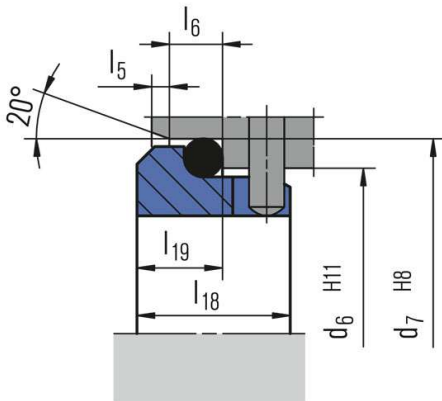

G16

(EN 12756 but l_{1k} and l_2 are shorter than specified)

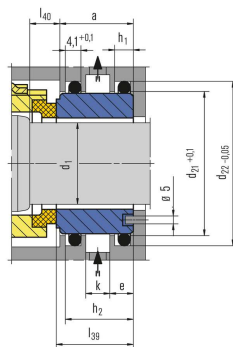

G115

Cooled seat especially for hot water applications. In this case, the dimensions of the H12N rotating unit are modified. Seal designation: H127G115. Please inquire.

RELY ON EXCELLENCE

Product variants

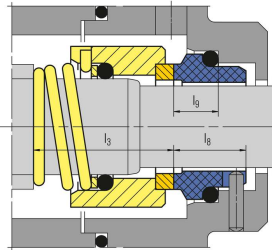

H17GN

Dimensions, items and descriptions as for H12N, but with shrink-fitted seal face (Q12), item no. 1.1.
 Temperature: $t = -20\text{ °C} \dots +180\text{ °C}$ ($-4\text{ °F} \dots +356\text{ °F}$)
 Seal face: Silicon carbide (Q12)
 Seat G9: Silicon carbide (Q1, Q2), Carbon graphite antimony impregnated (A), Carbon graphite resin impregnated (B)

H12

Dimensions, items and descriptions as for H12N, but with seat G16.
 Seal face: Carbon graphite antimony impregnated (A)
 Seat G16: Silicon carbide (Q1), CrMo cast steel (S), Aluminium oxide (V)

H17G

Dimensions, items and descriptions as for H12N, but with shrink-fitted seal face (Q12) and seat G16.
 Temperature: $t = -20\text{ °C} \dots +180\text{ °C}$ ($-4\text{ °F} \dots +356\text{ °F}$)
 Seal face: Silicon carbide (Q12)
 Seat G16: Silicon carbide (Q1)

RELY ON EXCELLENCE

Dimensions

d ₁	d ₂	d ₃	d ₆	d ₇	d ₈	d ₂₁	d ₂₂	d _b	l _{1N}	l ₁	l ₂	l ₃	l ₅	l ₆	l ₇	l ₈	l ₉	l ₁₈	l ₁₉	l ₃₉	l ₄₀	a	b	e	h ₁	h ₂	k	b*)
10	14	24	17	21	3	-	-	18	50	35.5	18	25.5	1.5	4	8.5	17.5	10.0	-	-	-	-	-	5	-	-	-	-	8.0
12	16	26	19	23	3	-	-	21	50	36.5	18	26.5	1.5	4	8.5	17.5	10.0	-	-	-	-	-	5	-	-	-	-	8.0
14	18	31	21	25	3	-	-	23	55	39.5	18	29.5	1.5	4	8.5	17.5	10.0	-	-	-	-	-	6	-	-	-	-	8.0
16	20	34	23	27	3	-	-	26	55	41.0	18	31.0	1.5	4	8.5	17.5	10.0	-	-	-	-	-	6	-	-	-	-	8.0
18	22	36	27	33	3	-	-	28	55	44.0	20	32.5	2.0	5	9.0	19.5	11.5	15	7	-	-	-	6	-	-	-	-	8.0
20	24	38	29	35	3	-	-	30	60	44.0	20	32.5	2.0	5	9.0	19.5	11.5	15	7	-	-	-	6	-	-	-	-	8.0
22	26	40	31	37	3	-	-	31	60	44.0	20	32.5	2.0	5	9.0	19.5	11.5	15	7	-	-	-	6	-	-	-	-	8.0
24	28	42	33	39	3	-	-	35	60	44.0	20	32.5	2.0	5	9.0	19.5	11.5	15	7	-	-	-	6	-	-	-	-	8.0
25	30	44	34	40	3	-	-	37	60	45.0	20	33.5	2.0	5	9.0	19.5	11.5	15	7	-	-	-	6	-	-	-	-	8.0
28	33	47	37	43	3	44.65	50.57	40	65	47.0	20	35.5	2.0	5	9.0	19.5	11.5	15	7	24	8.5	24	6	8	6.6	22.6	9	8.0
30	35	49	39	45	3	47.83	53.75	43	65	47.0	20	35.5	2.0	5	9.0	19.5	11.5	15	7	24.5	9.0	24	6	8	6.6	22.6	9	8.0
32	38	54	42	48	3	47.83	53.75	45	65	51.0	20	39.5	2.0	5	9.0	19.5	11.5	15	7	24.5	9.0	24	6	8	6.6	22.6	9	7.5
33	38	54	42	48	3	47.83	53.75	45	65	51.0	20	39.5	2.0	5	9.0	19.5	11.5	15	7	24.5	9.0	24	6	8	6.6	22.6	9	7.5
35	40	56	44	50	3	51	56.92	49	65	55.0	20	43.5	2.0	5	9.0	19.5	11.5	15	7	24.5	9.0	24	6	8	6.6	22.6	9	8.0
38	43	59	49	56	4	54.18	60.10	52	75	60.0	23	46.0	2.0	6	9.0	22.0	14.0	16	8	26	11	24	6	8	6.6	22.6	9	7.5
40	45	61	51	58	4	60.53	66.45	55	75	62.0	23	48.0	2.0	6	9.0	22.0	14.0	16	8	26	11	24	6	8	6.6	22.6	9	8.0
43	48	64	54	61	4	63.7	69.62	58	75	65.0	23	51.0	2.0	6	9.0	22.0	14.0	16	8	26	11	24	6	8	6.6	22.6	9	8.0
45	50	66	56	63	4	63.7	69.62	61	75	69.0	23	55.0	2.0	6	9.0	22.0	14.0	16	8	26	11	24	6	8	6.6	22.6	9	(8)
48	53	69	59	66	4	66.88	72.80	64	85	69.0	23	55.0	2.0	6	9.0	22.0	14.0	16	8	26	11	24	8	8	6.6	22.6	9	8.0
50	55	71	62	70	4	70.05	75.97	66	85	73.0	25	58.0	2.5	6	9.0	23.0	15.0	17	9.5	26.5	12.5	24	8	8	6.6	22.6	9	8.0
53	58	78	65	73	4	76.4	82.32	69	85	75.0	25	60.0	2.5	6	9.0	23.0	15.0	17	9.5	26.5	12.5	24	8	8	6.6	22.6	9	8.0
55	60	79	67	75	4	76.4	82.32	71	85	75.0	25	60.0	2.5	6	9.0	23.0	15.0	17	9.5	28.5	12.5	26	8	8	6.6	24.6	11	8.0
58	63	83	70	78	4	79.58	85.50	74	85	75.0	25	60.0	2.5	6	9.0	23.0	15.0	18	10.5	28.5	12.5	26	8	8	6.6	24.6	11	8.0
60	65	85	72	80	4	82.75	88.67	77	95	75.0	25	60.0	2.5	6	9.0	23.0	15.0	18	10.5	28.5	12.5	26	8	8	6.6	24.6	11	8.0
63	68	88	75	83	4	85.93	91.85	80	95	75.0	25	60.0	2.5	6	9.0	23.0	15.0	18	10.5	28.5	12.5	26	8	8	6.6	24.6	11	8.0
65	70	90	77	85	4	85.93	91.85	83	95	76.0	25	61.0	2.5	6	9.0	23.0	15.0	18	10.5	28.5	12.5	26	8	8	6.6	24.6	11	10.0
70	75	98	83	92	4	89.1	95.02	88	95	81.0	28	63.0	2.5	7	9.0	26.0	18.0	19	11.5	30.5	14.5	26	8	8	6.6	24.6	11	10.0
75	80	103	88	97	4	98.63	104.55	93	105	86.0	28	68.0	2.5	7	9.0	26.0	18.0	19	11.5	30.5	14.5	26	10	8	6.6	24.6	11	10.0
80	85	109	95	105	4	101.8	107.72	98	105	86.0	28	68.0	3.0	7	9.0	26.2	18.2	19	11.5	30.2	14	26	10	8	6.6	24.6	11	10.0

*) l_{1N} acc. to EN 12756 is exceeded.