

RELY ON EXCELLENCE

## CGSH-K

Mechanical seals | Mechanical seals for pumps | Gas-lubricated seals

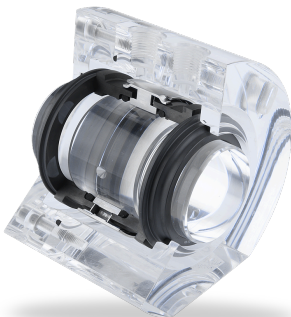

### Features

- For stepped shafts
- Balanced
- Rotating spring
- Single or double seal available
- Standard version with U-grooves, V-grooves optional (dependent of direction of rotation)
- Gas-lubricated
- Does not open in the event of buffer pressure failure, self closing at pressure reversal

### Advantages

- Contact-free operation, no friction
- No differential pressure required with hard/soft material combination
- Applicable as containment seal acc. to API 682

### Operating range

Shaft diameter:  
 $d_1 = 28 \dots 125 \text{ mm} (1.10" \dots 4.92")$   
 Pressure:  $p_1 = 25 \text{ bar} (363 \text{ PSI})$   
 Temperature:  
 $t^* = -20 \text{ °C} \dots +170 \text{ °C} (-4 \text{ °F} \dots +338 \text{ °F})$   
 Sliding velocity:  
 $vg = 4 \dots 25 \text{ m/s} (13 \dots 82 \text{ ft/s})$

\* Depending on resistance of O-Rings

### Materials

Seal face: Carbon graphite antimony impregnated (A), Silicon carbide (Q2), alternatively: Carbon graphite resin impregnated (B), Silicon carbide (Q1)  
 Seat: Silicon carbide (Q1, Q2), Silicon carbide (Q19, Q29) with seal face in Q1 resp. Q2  
 Metal parts: CrNiMo steel (G)

### Standards and approvals

- EN 12756
- API 682 / ISO 21049

### Recommended applications

- Chemical industry
- Refining technology
- Gases and liquids (single seals only gas)
- Gases and liquids which must not get into the atmosphere (dual seal)
- Gases not harmful to the environment (single seal)
- Fans
- Small steam turbines
- Blowers
- Roots compressors
- Pumps

## RELY ON EXCELLENCE

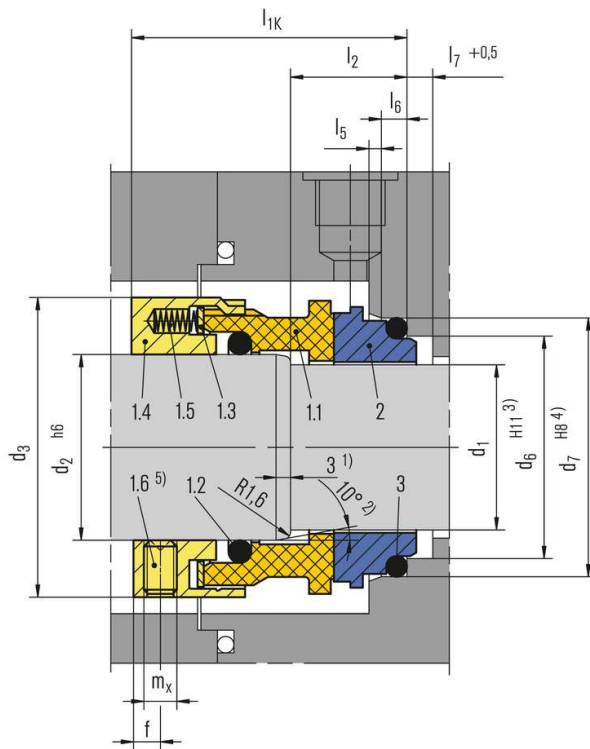

### Item Parts no. to Description DIN 24250

1.1	472	Sliding face
1.2	412.1	O-Ring
1.3	474	Thrust ring
1.4	485	Drive collar
1.5	477	Spring
1.6	904	Set screw
2	475.1	Seat
3	412.3	O-Ring

1)  $d1 > 105$ : 2 mm x 30°  
 2)  $d1 > 105$ : 30°  
 3)  $d1 > 105$ : +0.1  
 4)  $d1 > 105$ : H7  
 5) 3 x 120°

## RELY ON EXCELLENCE

### Product variants

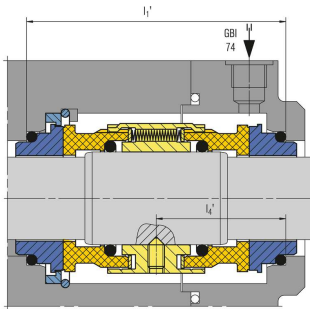

#### CGSH-KD

Double seal back-to-back, buffered with gas, according to API 682 configuration 3NC-BB, Plan 74. Items, descriptions and unspecified dimensions as for CGSH-K.

Pressure:  $p_1 = \dots 22 \text{ bar (319 PSI)}$ ,  $p_3 = \dots 25 \text{ bar (363 PSI)}$

(over the whole nominal diameter range, higher values on request).

Differential pressure  $\Delta p = \text{min. } 3 \text{ bar (44 PSI)}$

Other operating limits as CGSH-K.

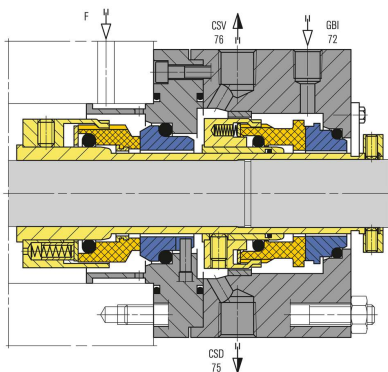

#### CGSH Tandem arrangement

acc. to API 682 3rd Edition.

Configuration: 2CW-CS, [API Plan 72](#), [API Plan 75](#), [API Plan 76](#).

For media with a gaseous leakage. H75VN on the product side. In case of a failure, the CGSH on the atmosphere side works as a liquid seal.

## RELY ON EXCELLENCE

### Dimensions

d <sub>1</sub>	d <sub>2</sub>	d <sub>3</sub>	d <sub>6</sub>	d <sub>7</sub>	l <sub>1K</sub>	l <sub>1'</sub>	l <sub>2</sub>	l <sub>4'</sub>	l <sub>5</sub>	l <sub>6</sub>	l <sub>7</sub>	f	m <sub>x</sub>
28*	33	53	37.0	43.0	50.0	89	20	44.5	2.0	5	9	5	M6
30*	35	55	39.0	45.0	50.0	89	20	44.5	2.0	5	9	5	M6
32*	38	60	42.0	48.0	50.0	89	20	44.5	2.0	5	9	5	M6
33*	38	60	42.0	48.0	50.0	89	20	44.5	2.0	5	9	5	M6
35*	40	62	44.0	50.0	50.0	89	20	44.5	2.0	5	9	5	M6
38*	43	65	49.0	56.0	52.5	95	23	47.5	2.0	6	9	5	M6
40*	45	67	51.0	58.0	52.5	95	23	47.5	2.0	6	9	5	M6
43*	48	70	54.0	61.0	52.5	95	23	47.5	2.0	6	9	5	M6
45*	50	72	56.0	63.0	52.5	95	23	47.5	2.0	6	9	5	M6
48*	53	75	59.0	66.0	52.5	95	23	47.5	2.0	6	9	5	M6
50*	55	77	62.0	70.0	57.5	104	25	52.0	2.5	6	9	5	M6
53*	58	84	65.0	73.0	57.5	104	25	52.0	2.5	6	9	5	M6
55*	60	86	67.0	75.0	57.5	106	25	53.0	2.5	6	9	5	M6
58*	63	89	70.0	78.0	62.5	112	25	56.0	2.5	6	9	7	M8
60*	65	91	72.0	80.0	62.5	112	25	56.0	2.5	6	9	7	M8
63*	68	94	75.0	83.0	62.5	112	25	56.0	2.5	6	9	7	M8
65*	70	97	77.0	85.0	62.5	112	25	56.0	2.5	6	9	7	M8
70*	75	104	83.0	92.0	70.0	126	28	63.0	2.5	7	9	7	M8
75*	80	109	88.0	97.0	70.0	126	28	63.0	2.5	7	9	7	M8
80*	85	114	95.0	105.0	70.0	126	28	63.0	3.0	7	9	7	M8
85*	90	119	100.0	110.0	75.0	126	28	63.0	3.0	7	9	7	M8
90*	95	124	105.0	115.0	75.0	126	28	63.0	3.0	7	9	7	M8
95*	100	129	110.0	120.0	75.0	126	28	63.0	3.0	7	9	7	M8
100*	105	132	115.0	125.0	75.0	126	28	63.0	3.0	7	9	7	M8
105*	115	153	122.2	134.3	73.0	136	32	68.0	2.0	10	-	7	M8
110*	120	158	128.2	140.3	73.0	136	32	68.0	2.0	10	-	7	M8
115*	125	163	136.2	148.3	73.0	136	32	68.0	2.0	10	-	7	M8
120*	130	168	138.2	150.3	73.0	136	32	68.0	2.0	10	-	7	M8
125*	135	173	142.2	154.3	73.0	136	32	68.0	2.0	10	-	7	M8

Dimensions in millimeter

\* EN 12756