

RELY ON EXCELLENCE

AGSZ

Mechanical seals | Agitator seals | Gas-lubricated seals

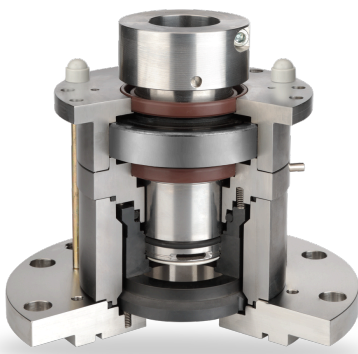

Features

- For top entry drives
- Double seal
- Balanced
- Independent of direction of rotation
- Gas-lubricated
- Cartridge unit

Advantages

- Ready-to-fit and factory-tested unit
- Central rotating seat
- Torque transmission by clamping ring for large axial movements
- Non-contacting operation
- No friction on the seal faces, no heat generated at the seal or in the medium
- ATEX certification on request

Operating range

Shaft diameter:

$d_1 = 40 \dots 220 \text{ mm (1.6" ... 8.7")}$

Pressure:

$p_1 = \text{vacuum} \dots 6 \text{ bar (87 PSI)}$,

$\Delta p = \text{min. } 3 \text{ bar (44 PSI)}$, $p_3 = 9 \text{ bar (131 PSI)}$

Temperature:

$t_1 = 0 \text{ }^\circ\text{C} \dots +200 (+250^*) \text{ }^\circ\text{C}$

$(+32 \text{ }^\circ\text{F} \dots +392 (+482^*) \text{ }^\circ\text{F})$

Sliding velocity:

$v_g = 0 \dots 5 \text{ m/s (0 ... 16 ft/s)}$,

higher velocities on request.

* with cooling flange

! It should be noted that the extremal values of each operating parameter cannot be applied at the same time because of their interaction.

Materials

Seal faces and seats: Silicon carbide, FDA conform

Secondary seals and metallic parts acc. to application and customers' requirement.

Standards and approvals

- FDA
- ATEX
- DIN 28138 (mechanical seals for agitator shafts)
- DIN 28136 T2 (for steel vessels)
- DIN 28141 (flange connection for steel vessels)
- DIN 28154 (shaft end for steel vessels)
- DIN 28136 T3 (for glass-lined vessels)
- DIN 28137 T2 (flange connection for glass-lined vessels)
- DIN 28159 (shaft end for glass-lined vessels)

Notes

Options:

- Cooling resp. heating flange
- Flush
- Hygienic flange

Recommended applications

- Chemical industry
- Food and beverage industry
- Pharmaceutical industry
- Gases and liquids
- Media which require high purity
- Agitators
- Reactors

Recommended piping plans

Gas supply by EagleBurgmann

GSS4015/A400-D0,

GSS4016/A250-D1 or GSS4016/A350-D1.

Note: To assure a sufficient supply of the

RELY ON EXCELLENCE

mechanical seal, pressure at entry of the supply system must be min. 3 bar (44 PSI) above max. barrier pressure always.

Product link:

[EagleBurgmann GSS](#)

Item Description

- 1 Seal face, atmosphere side
- 2 Seal face, product side
- 6, 7 O-Ring
- 11 Seat
- 17 Flange
- 22 Clamping ring

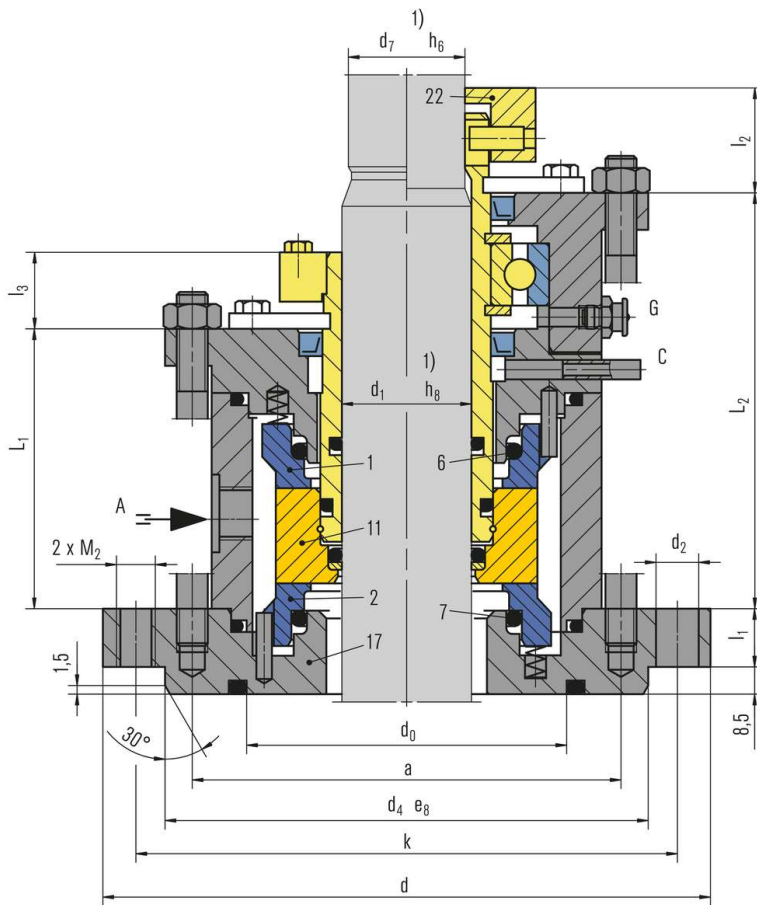

RELY ON EXCELLENCE

Torque transmissions

Shrink disk

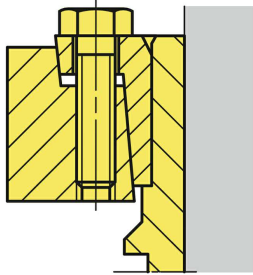

Clamping ring with pin

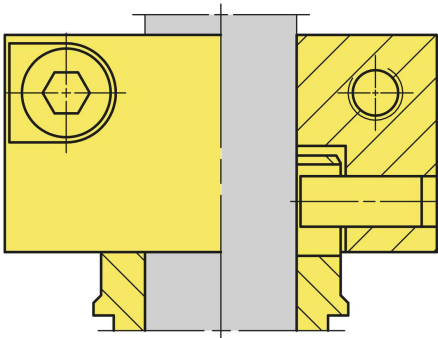

Clamping ring

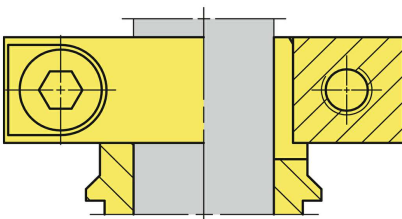

RELY ON EXCELLENCE

Installation, details, options

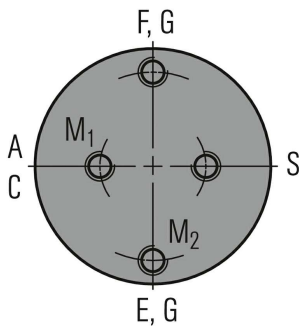

Supply connections

Designation and positions of supply connections, pull-off and jacket threads acc. to DIN 28138 T3.

- A Barrier gas IN
- C Leakage
- E Cooling IN
- F Cooling OUT
- S Flush
- G Grease

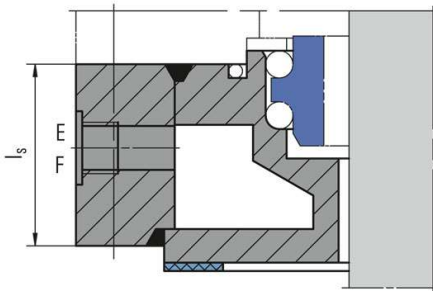

Cooling flange

Can be used alternatively as a heating flange.

RELY ON EXCELLENCE

Product variants

AGSZ461K(L)-D Flange connection acc. to DIN 28137 T2 for nominal diameters 40 ... 100.

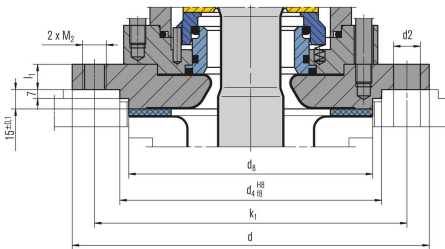

AGSZ461K(L)-D Flange connection acc. to DIN 28137 T2 for nominal diameters 125 ... 161.

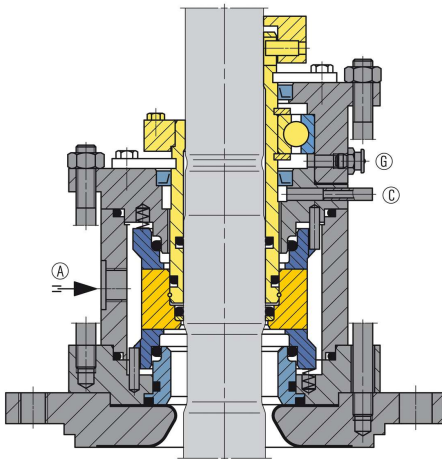

AGSZ481K(L)-D

Double seal (with integrated bearing) for steel vessels to DIN 28136, connection flange to DIN 28141 and shaft ends to DIN 28154.

AGSZ461K(L)-D

Double seal (with integrated bearing) for glass-lined vessels to DIN 28136, connection flange to DIN 28137 and shaft ends to DIN 28159.

AGSZ451K(L)-D

Version with special connection dimensions or unstepped shafts. For steel vessels.

AGSZ491K(L)-D

Variant with special connection dimensions for glass-lined vessels.

RELY ON EXCELLENCE

Dimensions

d ₁ ¹⁾	d ₇ ¹⁾	d	nx d ₂	d ₄	d ₀	k	L ₁	L ₂	L _w ¹⁾	l ₁	l ₂	l ₃	A	M ₁	M ₂	A, B
40	38	175	4x18	110	90	145	81	137	143	15	35	28	122	M12	M16	G3/8
50	48	240	8x18	176	135	210	82.5	130.5	148	17	42	28	155	M12	M16	G3/8
60	58	240	8x18	176	135	210	78.5	128	158	18	39	28	176	M12	M16	G3/8
80	78	275	8x22	204	155	240	94.5	146	168	20	50	34	203	M16	M20	G1/2
100	98	305	8x22	234	190	270	95	156.5	178	20	56.5	34	228	M16	M20	G1/2
125	120	330	8x22	260	215	295	95	163.5	203	20	60	39	268	M20	M20	G1/2
140	135	395	12x22	313	250	350	97	168.5	208	20	82	41	285	M20	M20	G1/2
160	150	395	12x22	313	265	350	97	176.5	213	25	81	41	302	M20	M20	G1/2
180	170	445	12x22	364	310	400	-	-	233	25	-	-	332	M24	M20	G1/2
200	190	445	12x22	364	310	400	-	-	243	25	-	-	352	M24	M20	G1/2
220	210	505	16x22	422	340	460	-	-	263	25	-	-	-	M24	M20	G1/2

AGSZ481 - Dimensions in millimeter

1) Shaft diameters d₁ and d₇ to DIN 28154

Dimensions

d ₁ ¹⁾	d ₇ ¹⁾	Nominal size	Flange size ²⁾	d	nx d ₂	d ₄	nx d ₅	d ₆	d ₇	k ₁	k ₂	l ₁	l ₂	l ₁	l ₂	l ₃	l ₄	l ₅	M ₁	M ₂	A
40	38	40	E125	175	4x18	110	-	-	102	145	-	142	184	25	35	28	50	50	M12	M16	G3/8
50	48	50	E200	240	8x18	176	-	-	138	210	-	147	195	25	40	28	50	50	M12	M16	G3/8
60	58	60	E250	275	8x22	204	-	-	188	240	-	158	203	25	42	28	50	60	M12	M20	G3/8
80	78	80	E300	305	8x22	234	-	-	212	270	-	170	240	30	45	34	60	60	M16	M20	G1/2
100	98	100	E400	395	12x22	313	-	-	268	350	-	177	240	30	52	34	60	60	M16	M20	G1/2
100	98	100	E500	395	12x22	313	-	-	268	350	-	177	240	30	52	34	60	60	M16	M20	G1/2
125	120	125	E700	505	4x22	422	12x22	320	306	460	350	208	266	30	75	40	60	80	M20	M20	G1/2
140	135	140	E700	505	4x22	422	12x22	320	306	460	350	223	282	30	79	40	60	80	M20	M20	G1/2
160	150	160	E700	505	4x22	422	12x22	320	306	460	350	228	282	30	77	40	60	85	M20	M20	G1/2
160	150	160	E900	505	4x22	422	12x22	320	306	460	350	228	282	30	77	40	60	85	M20	M20	G1/2
160	150	161	E901	565	4x26	474	12x22	370	356	515	400	228	282	30	77	40	60	85	M20	M20	G1/2

AGSZ461 - Dimensions in millimeter

1) Shaft diameters d₁ and d₇ to DIN 28159

2) Flange size to DIN 28137 T2