

# THS Type Structural Drawing



## THS Type (Pressure Conveyance)

Pressure: 0~8000 mmAq

Power: 10~250 HP

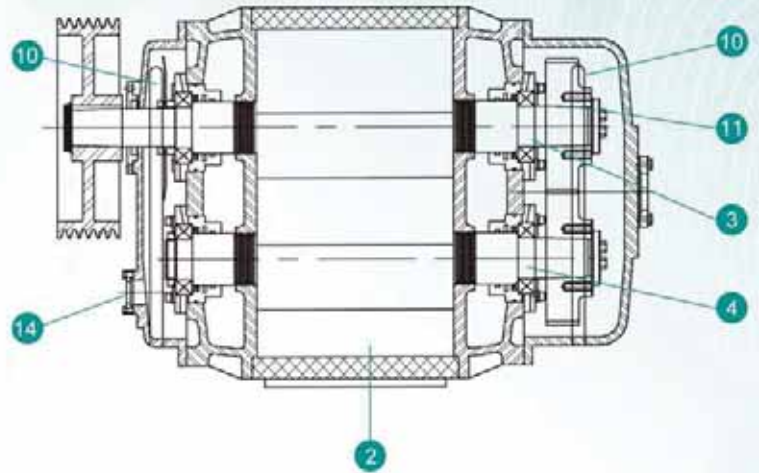

THS Type Structural Drawing

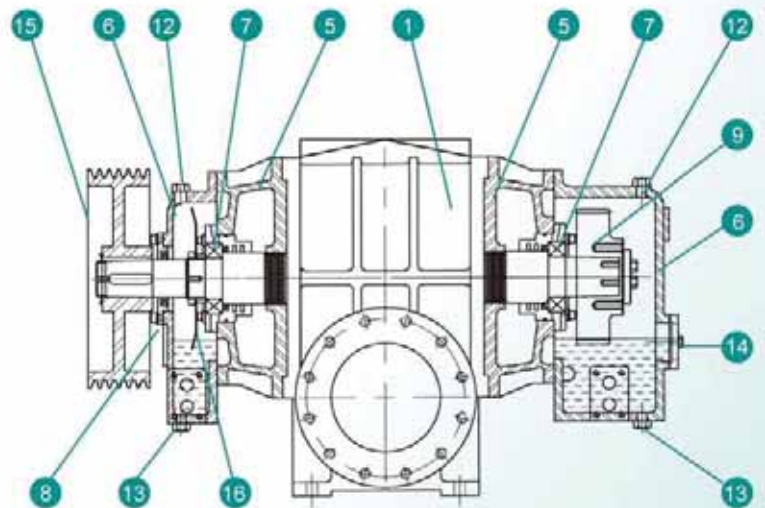

NO.	Name	Material	Q'ty	NO.	Name	Material	NO.
1	Main body	FC25	1	9	Gear	SNCM220	2
2	Rotor	FC25	2	10	"S"Ring	Brass	2
3	Drive Shaft	S45C	1	11	Washer	S45C	2
4	Driven Shaft	S45C	1	12	Lubrication Plug	PP	2
5	Bearing Base	FC25	2	13	Drain Plug	FCMB28	2
6	Oil Box	FC25	2	14	Oil Gauge	BRASS	2
7	Bearing	SUJ2	4	15	Pulley	FC20	1
8	Oil Seal	NBR	1	16	Oil Splasher	SS41	1

※ Could be manufactured by special material

## THS Type Performance Table (Pressure Conveyance)

Models	Speed	4000 mmAq		5000 mmAq		6000 mmAq		7000 mmAq		8000 mmAq		Cooling Water
	R.P.M	m <sup>3</sup> /min	kw	m <sup>3</sup> /min	kw	m <sup>3</sup> /min	kw	m <sup>3</sup> /min	kw	m <sup>3</sup> /min	kw	L / min
THS-80	1150	4.16	5.0	3.87	6.0	3.61	7.1	3.41	8.2	3.18	9.2	8
	1300	5.05	5.6	4.76	6.8	4.51	8.0	4.30	9.2	4.08	10.4	
	1450	5.96	6.3	5.66	7.6	5.41	9.0	5.20	10.3	4.98	11.6	
	1600	6.85	6.9	6.55	8.4	6.30	9.9	6.09	11.4	5.87	12.8	
	1750	7.75	7.6	7.45	9.2	7.20	10.8	6.99	12.4	6.77	14.0	
THS-100	1150	6.19	7.1	5.82	8.6	5.56	10.1	5.16	11.6	4.98	13.1	10
	1300	7.89	8.0	7.57	9.7	7.31	11.4	7.00	13.1	6.79	14.8	
	1450	9.14	9.0	8.82	10.8	8.57	12.7	8.25	14.6	8.04	16.5	
	1600	10.40	9.9	10.10	12.0	9.82	14.1	9.51	16.2	9.30	18.2	
	1750	11.60	10.8	11.30	13.1	11.00	15.4	10.70	17.7	10.55	19.9	
THS-125A	970	11.6	13.0	11.1	15.7	10.6	18.5	10.1	21.4	9.8	24.2	15
	1150	14.8	15.4	14.3	18.6	13.8	22.0	13.3	25.4	13.0	28.7	
	1300	17.5	17.4	16.9	21.0	16.5	24.8	16.0	28.7	15.6	32.4	
	1450	20.1	19.4	19.6	23.4	19.1	27.7	18.6	32.0	18.3	36.2	
	1600	22.8	21.4	22.3	25.9	21.8	30.6	21.3	35.3	20.9	39.9	
THS-150A	850	17.5	18.4	16.6	22.6	16.1	26.7	16.0	28.2	15.7	31.8	18
	1000	21.7	21.7	20.9	26.6	20.3	31.4	20.1	33.4	19.8	37.7	
	1150	25.9	22.8	25.2	30.6	24.5	36.1	23.6	37.8	23.2	42.6	
	1250	28.8	27.2	28.0	33.3	27.3	39.3	27.0	42.1	26.7	47.5	
	1400	33.0	30.4	32.3	37.3	31.6	44.0	30.4	46.5	30.1	52.5	
THS-200	850	24.3	23.7	23.5	29.1	22.9	34.6	22.3	39.7	21.7	45.1	20
	950	28.1	26.6	27.3	32.6	26.7	38.7	26.1	44.4	25.5	50.5	
	1050	31.9	29.5	31.1	36.1	30.5	42.8	29.9	49.1	29.3	55.9	
	1150	35.7	32.3	34.8	39.5	34.2	46.8	33.6	53.8	33.1	61.2	
	1250	39.5	35.2	38.6	43.0	38.0	50.9	37.4	58.5	36.9	66.6	
THS-250	850	39.1	35.9	38.1	44.2	37.1	52.3	36.2	60.3	35.3	68.6	25
	950	44.9	40.1	43.9	49.4	42.9	58.4	42.0	67.4	41.1	76.7	
	1050	50.7	44.3	49.7	54.6	48.7	64.5	47.8	74.5	46.9	84.8	
	1150	56.5	48.5	55.4	59.7	54.4	70.6	53.5	81.6	52.6	92.8	
	1250	62.3	52.7	61.2	64.9	60.2	76.7	59.3	88.7	58.4	100.9	
THS-300	730	47.8	50.8	46.5	62.5	45.4	74.8	44.3	85.8	43.5	97.6	30
	800	53.4	55.4	52.0	68.1	50.9	81.6	49.8	93.6	49.0	106.4	
	880	59.7	60.7	58.3	74.6	57.2	89.4	56.1	102.5	55.2	116.5	
	980	67.8	66.9	66.4	82.3	65.2	98.6	64.1	113.1	63.2	128.8	
	1080	76.0	73.8	74.6	90.8	73.4	108.7	72.3	124.9	71.4	141.7	
	1180	84.1	80.6	82.7	99.2	81.6	118.7	80.5	136.6	79.6	154.6	
THS-300A	650	68.1	72.5	66.3	89.7	64.8	97.8	63.2	123.0	61.8	139.2	35
	730	78.6	80.5	76.9	100.0	75.3	118.5	73.7	138.0	72.4	156.4	
	800	87.8	88.6	86.1	109.3	84.5	130.0	82.9	150.7	81.5	171.4	
	880	98.4	97.8	96.6	120.8	95.1	143.8	93.5	165.6	92.1	188.6	
	980	109.6	109.3	108.9	134.6	108.1	159.9	106.6	185.2	105.2	210.5	

# THS Type Performance Curve (Pressure Conveyance)

THS Type Performance Curve

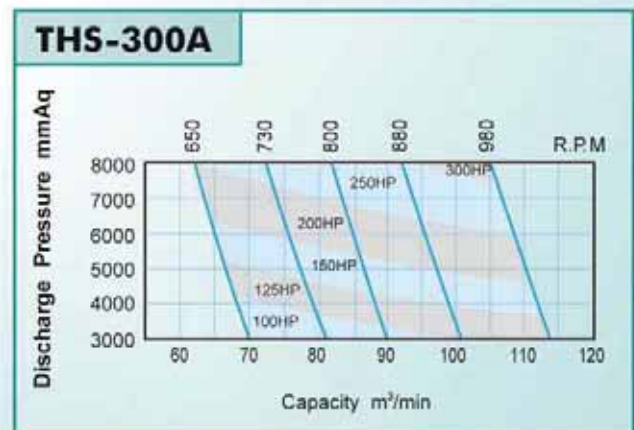
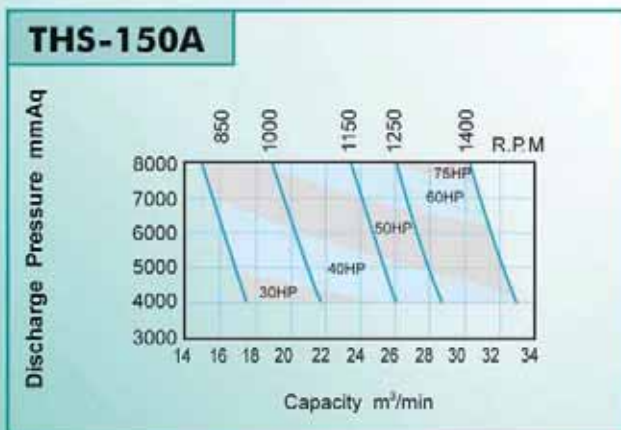
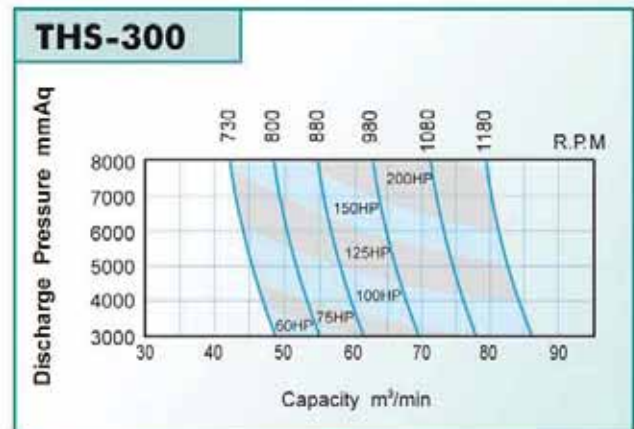
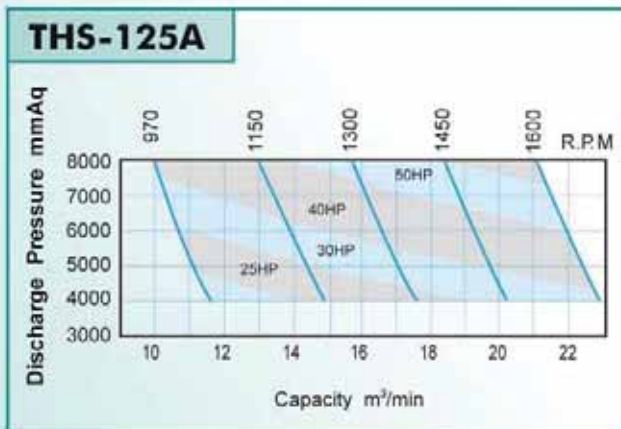
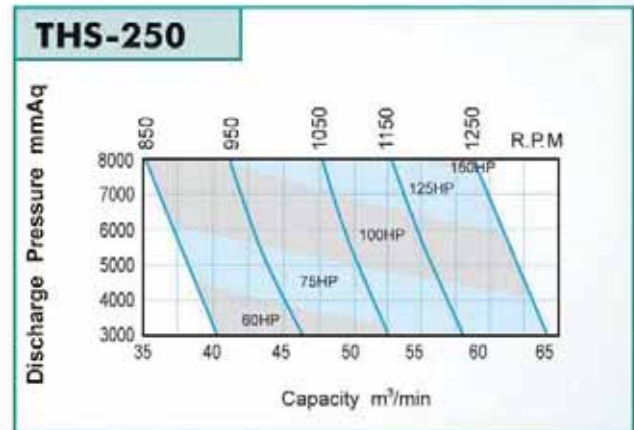
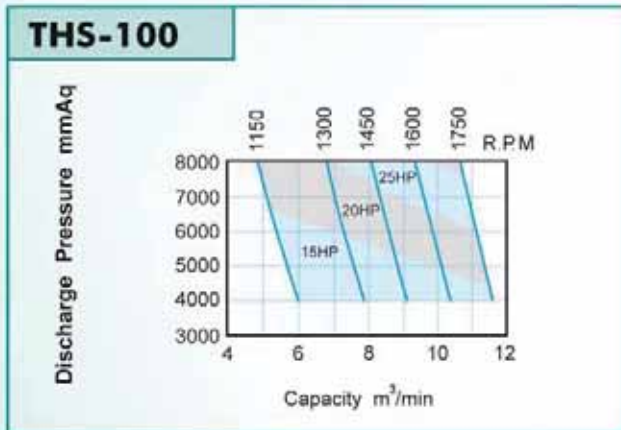
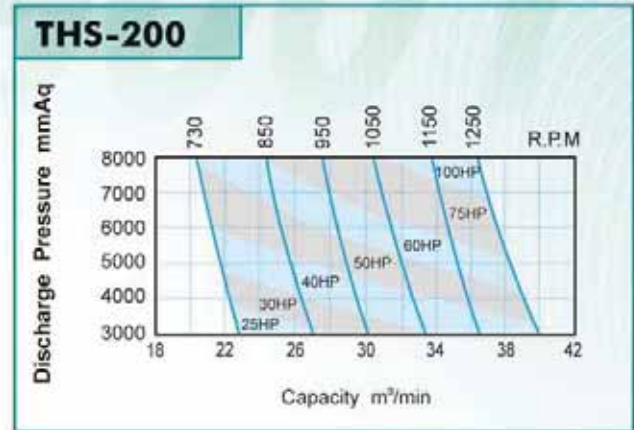
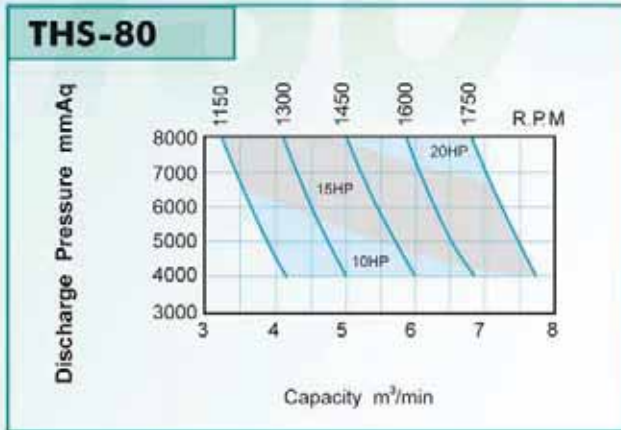

# THS Type Dimension Drawing

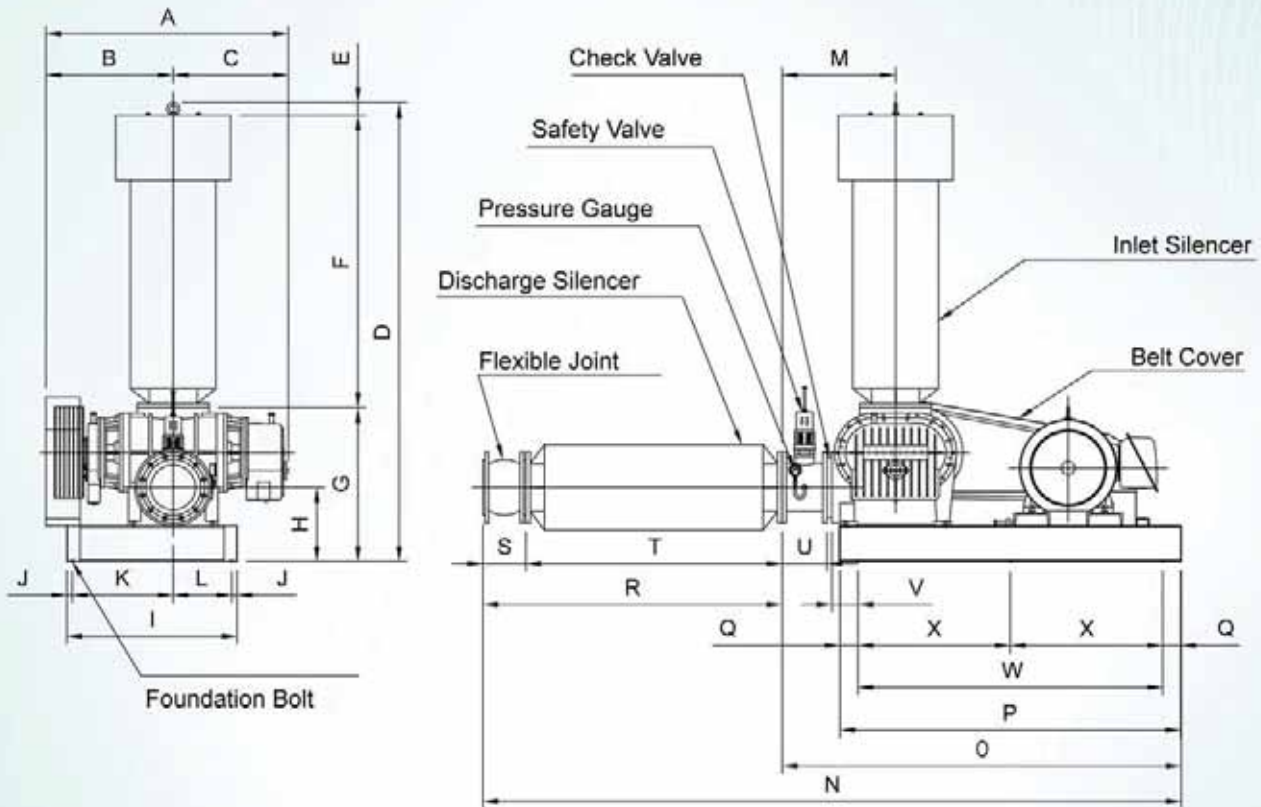

Models	A	B	C	D	E	F	G	H	I	J	K	L	M	N	O	P	Q	R	S	T	U	V	W	X	W1	W2
THS-80	711	390	322	1248	51	782	415	183	470	18	247	187	380	2052	1130	900	100	923	130	793	185	129	700		170	253
THS-100	807	435	372	1318	51	841	426	196	470	18	292	142	380	2062	1130	900	100	932	135	797	185	129	700		185	287
THS-125	514	420	394	2082	60	1492	530	230	600	22	258	298	451	2946	1354	1100	100	1592	170	1422	200	138	900		345	519
THS-125A	938	478	460	2082	60	1492	530	230	600	22	298	258	451	2946	1354	1100	100	1592	170	1422	200	138	900		388	563
THS-150A	1066	555	511	2180	60	1492	628	275	600	25	395	155	511	3277	1671	1400	100	1606	181	1426	200	155	1200		625	822
THS-200	1174	624	550	2563	71	1832	860	380	950	30	477	413	583	3804	2173	1900	100	1831	205	1426	200	145		850	810	1224
THS-250	1355	710	645	2563	71	1832	860	415	950	30	563	327	633	3893	2223	1900	100	1670	240	1430	250	145		850	970	1436
THS-300	1531	797	734	2618	71	1832	915	433	950	30	590	300	687	3971	2281	1900	100	1690	260	1430	300	145		850	1120	1687
THS-300A	1404	747	657	2898	71	1832	995	435	1300	30	721	519	782	4280	2590	2200	150	1890	260	1430	300	208	1900		1575	2182

W1 : Weight of main body only. (Kg)

W2 : Weight of main body and all accessories which include Inlet & Discharge Silencer, Base Plate, T-Joint, Safety Valve, Check Valve, Belt Cover and Flexible Joint, doesn't include motor. (Kg)

THS Type Dimension Drawing