

터보 송풍기(이송용)

Turbo blowers for transfer



TBS-S3235S(1HP)
TBS-S3235T(1HP)

도면(Unit: mm)

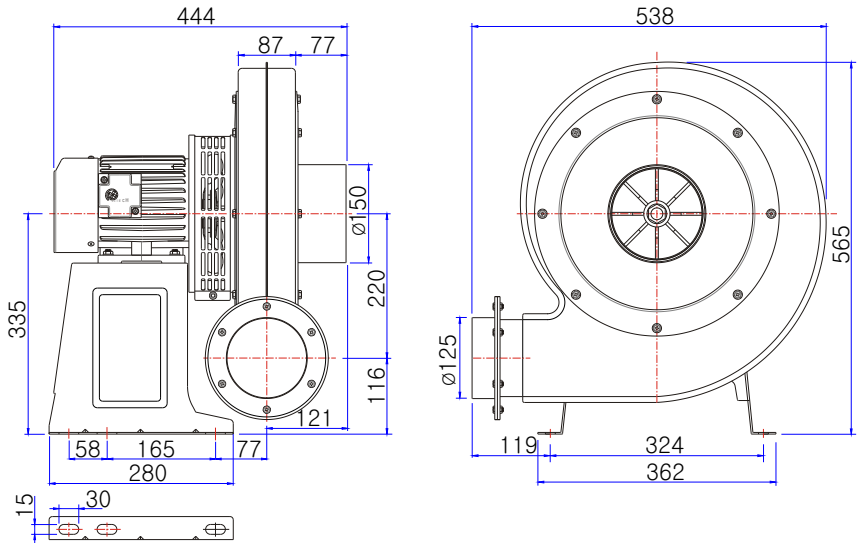

※.고온용 흡입온도 150℃까지 사용가능

성능곡선

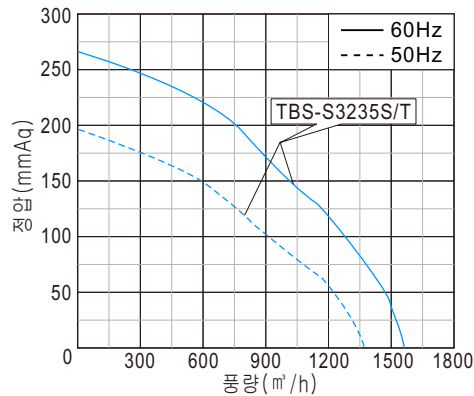

※본 제품은 50/60Hz 겸용입니다.(단상은 제외)

모델 Model	전원 Source (ϕ / V/Hz)	날개크기 Impeller Size (mm)	전류 Current (A)	극수 Pole (P)	소비전력 Input (W)	최대풍량 Air Volume (m^3/h)	최대정압 Air Pressure (mmAq) (Pa)	회전수 Rated Speed (rpm)	중량 Weight (Kg)
TBS-S3235S	1/220/60	$\phi 320 \times 35T$	6.3	2	1,360	1,560	265, 2,597	3,410	29.2
	1/220/50		4.2		880	1,365	196, 1,920	2,850	
TBS-S3235T	3/220-380/60	$\phi 320 \times 35T$	4.0-2.2	2	1,300	1,560	265, 2,597	3,410	28.7
	3/220-380/50		3.6-2.2		870	1,365	196, 1,920	2,850	

※본 제품의 사양은 품질개선을 위하여 예고없이 변경되는 경우가 있습니다.