



atlantic blowers

Phase	Model Number	Curve Number	Frequency (Hz)	KW	HP	Max Flow (SCFM)	Max Pressure ("H ₂ O)	Max Vacuum ("H ₂ O)	Sound Level (dB)	Inlet/Outlet Diameter (Inches)	Voltage	Current (A)	Weight (lbs)
3	AB-1802	A127	60Hz	22.00	30.00	812	141	161	84	4.00"	220-275/380-480	76.0Δ/44.0Y	405
			50Hz	20.00	26.80	677	98	112	80		200-240/345-415	66.7Δ/38.6Y	

**Sound db measured at 3ft.

MODEL NO. : AB-1802 DOUBLE STAGE

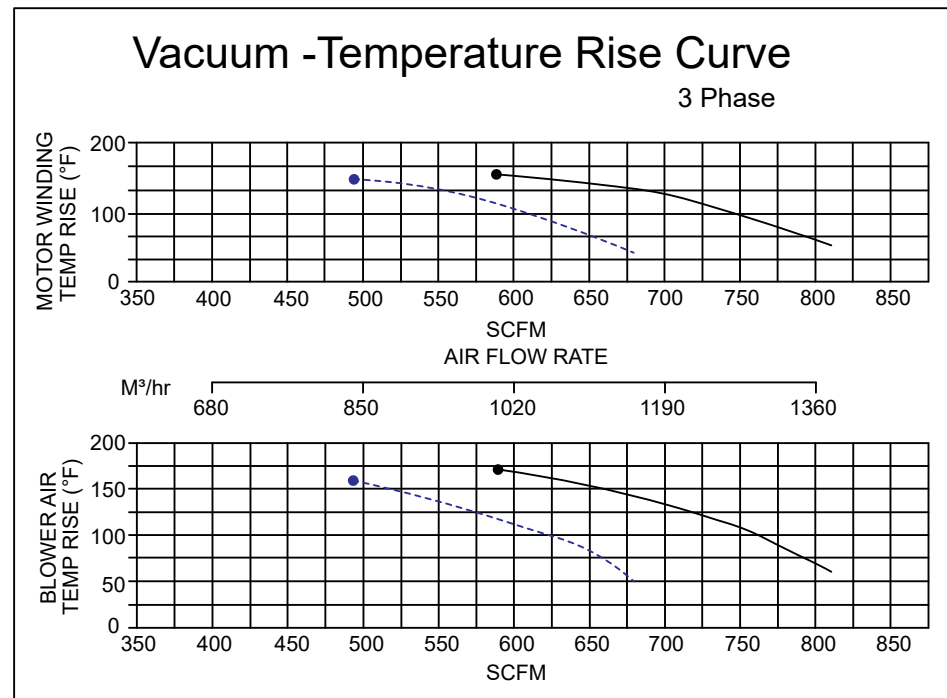
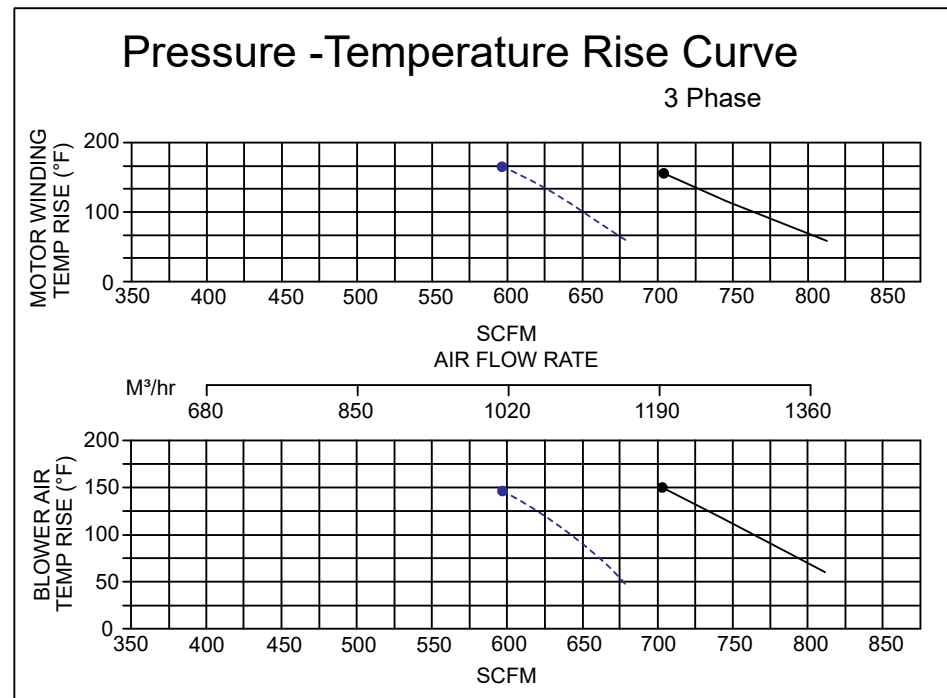
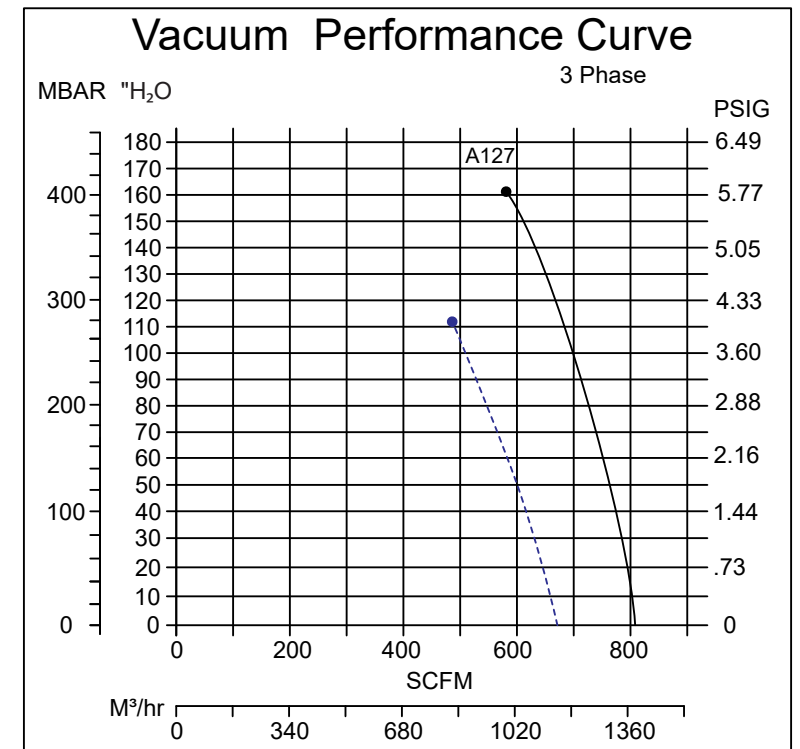
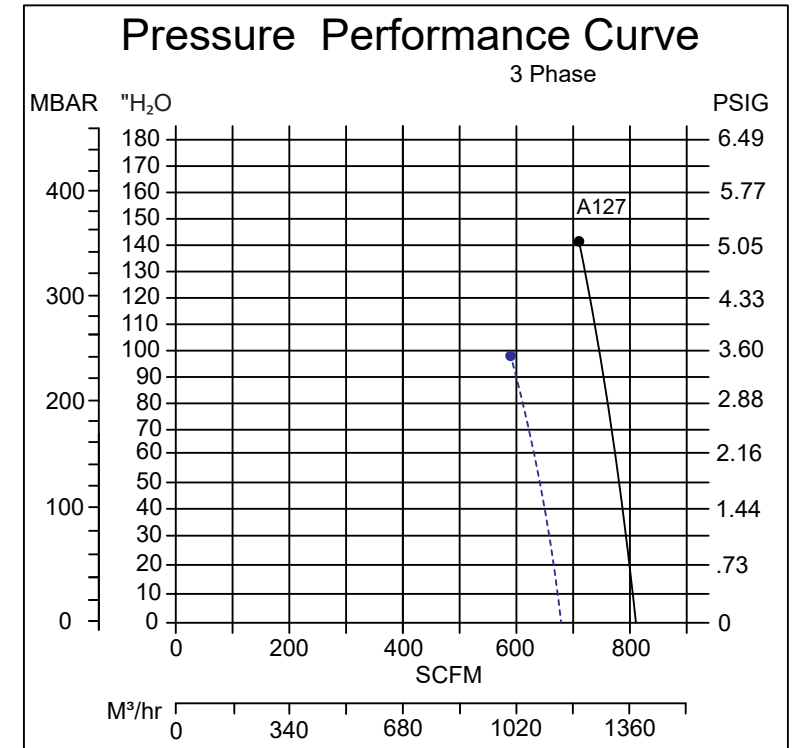
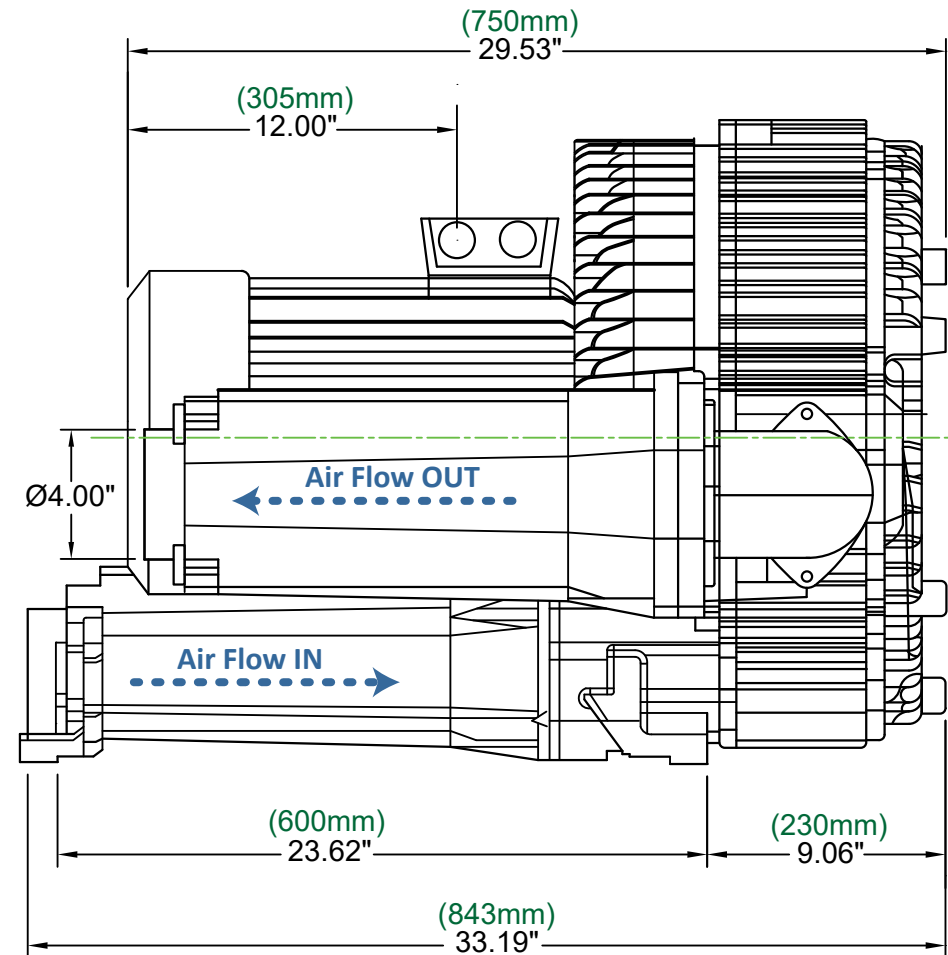
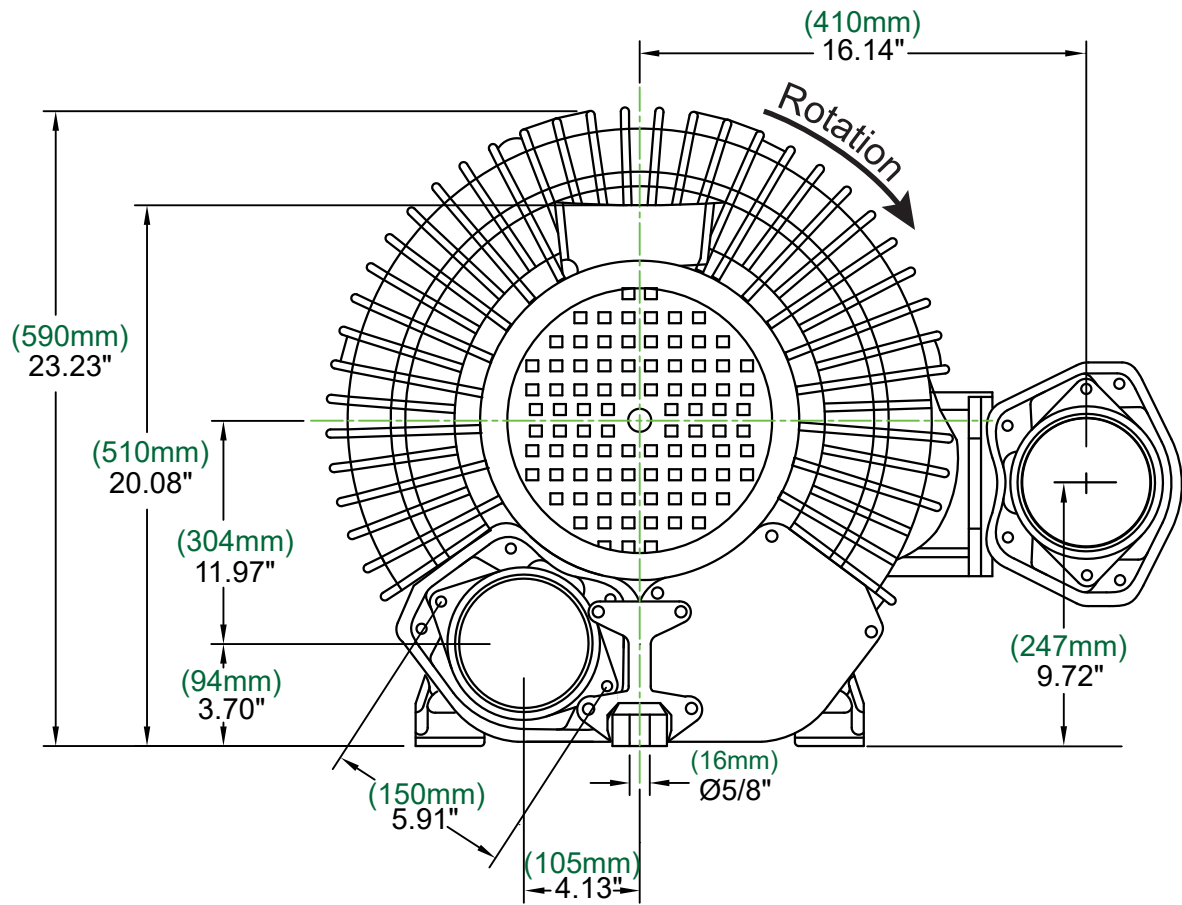

Key

— 60Hz
 - - - 50Hz

Standard Conditions
 -Sea Level (14.69 PSI)
 -60°F (15°C)
 -0% Relative Humidity

Disclaimer
 Ownership of this document and all accompanying information and data including but not limited to all applicable copyrights, trade secrets, patents and other intellectual property remain the property of Atlantic Blowers and are not to be copied, duplicated or reproduced, nor transmitted or disclosed to a third party without express written permission from Atlantic Blowers. Atlantic Blowers makes no representation or warranties, express or implied, with respect to the reuse of the data provided herewith, regardless of its format or the means of its transmission. The user accepts the data "as is", and assumes all risks associated with its use.