

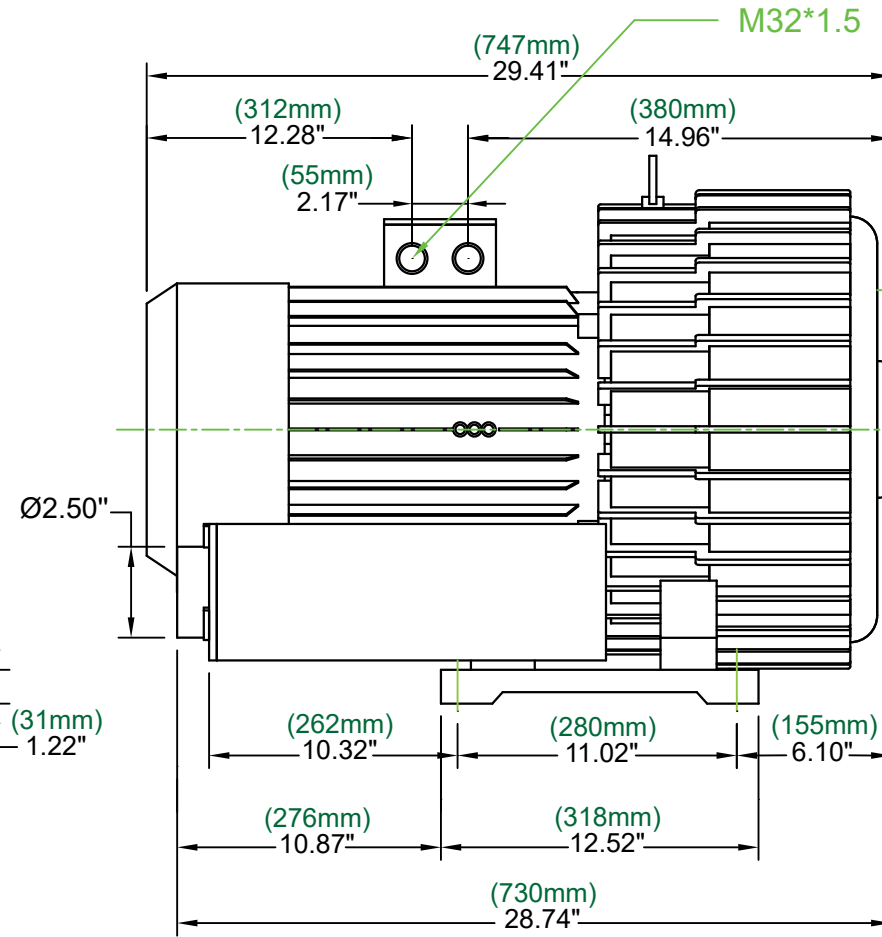

Phase	Model Number	Curve Number	Frequency (Hz)	KW	HP	Max Flow (SCFM)	Max Pressure ("H ₂ O)	Max Vacuum ("H ₂ O)	Sound Level (dB)	Inlet/Outlet Diameter (Inches)	Voltage	Current (A)	Weight (lbs)
3	AB-1502	A124	60Hz	26.80	35.00	776	189	189	81	2.50"	220-275/380-480	82.0Δ/46.0Y	400
			50Hz	22.30	29.00	647	131	131	77		200-240/345-415	68.3Δ/38.3Y	

**Sound db measured at 3ft.

MODEL NO. : AB-1502 DOUBLE STAGE

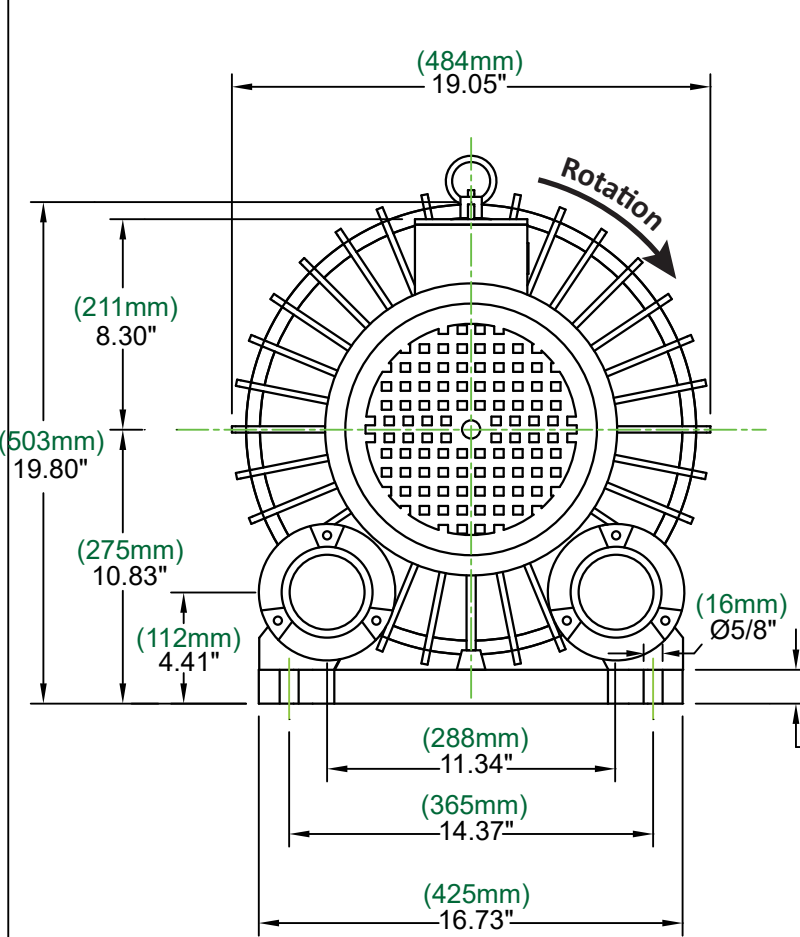

Key
 — 60Hz
 - - - 50Hz

Standard Conditions
 -Sea Level (14.69 PSI)
 -60°F (15°C)
 -0% Relative Humidity

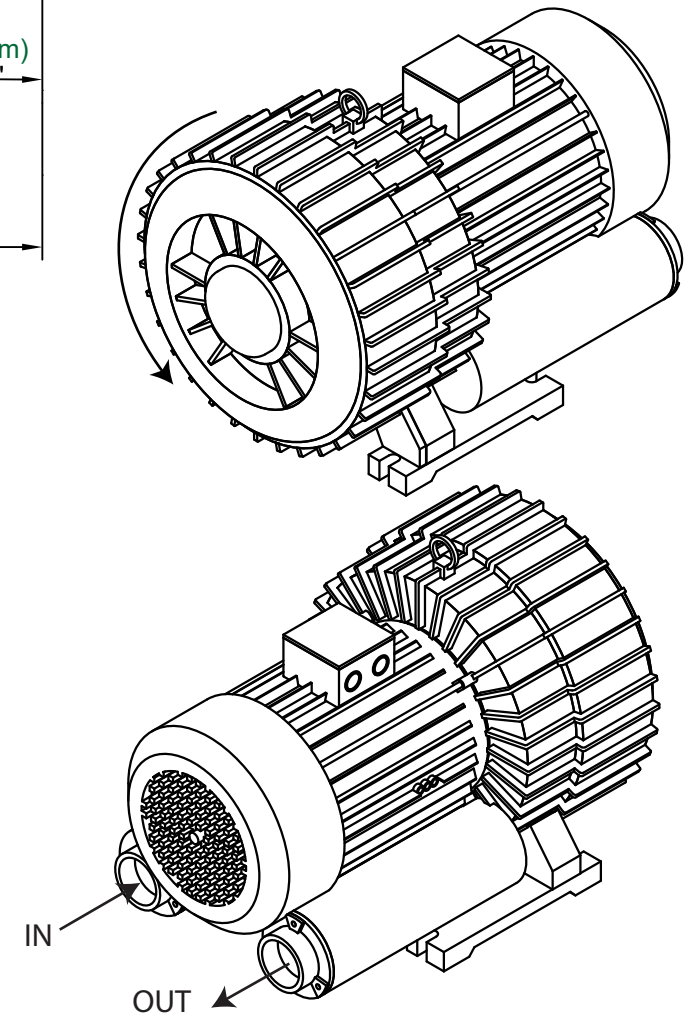
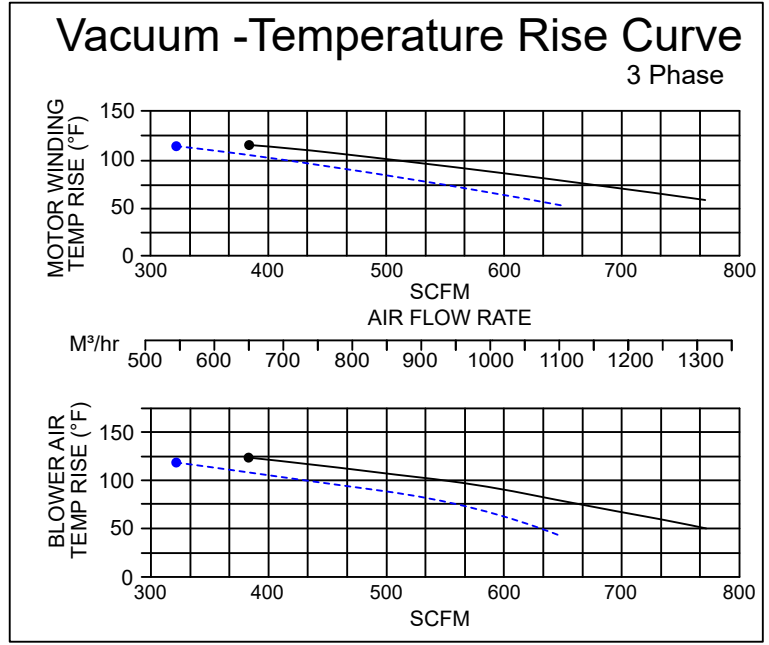
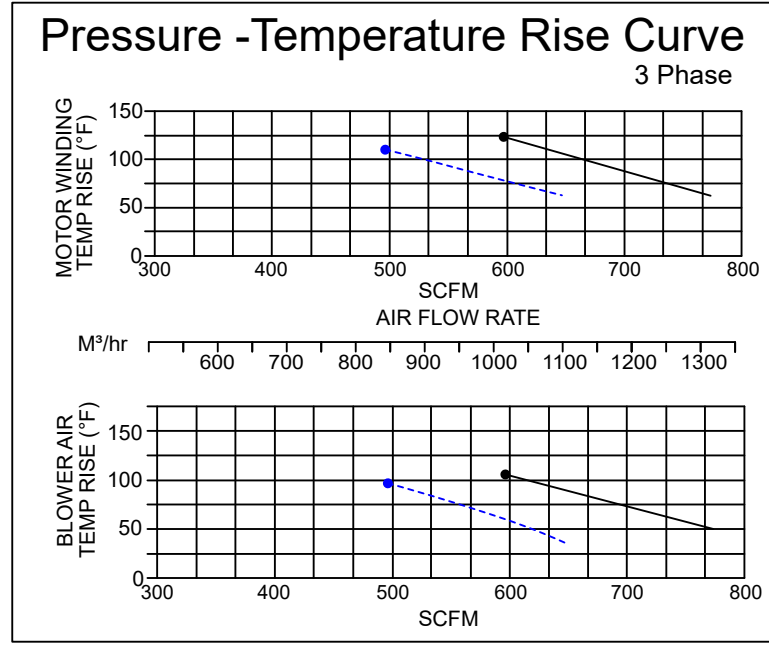
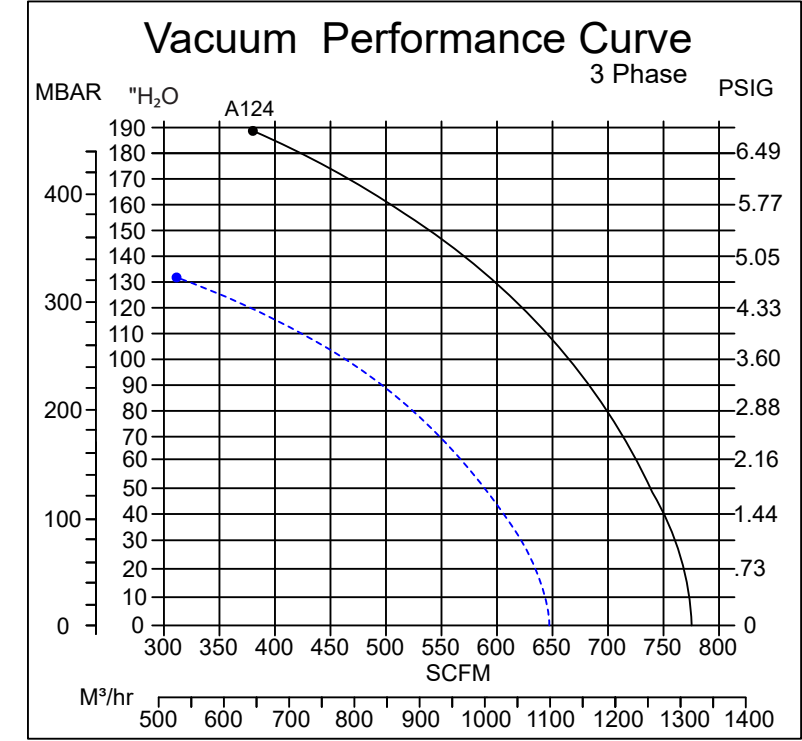
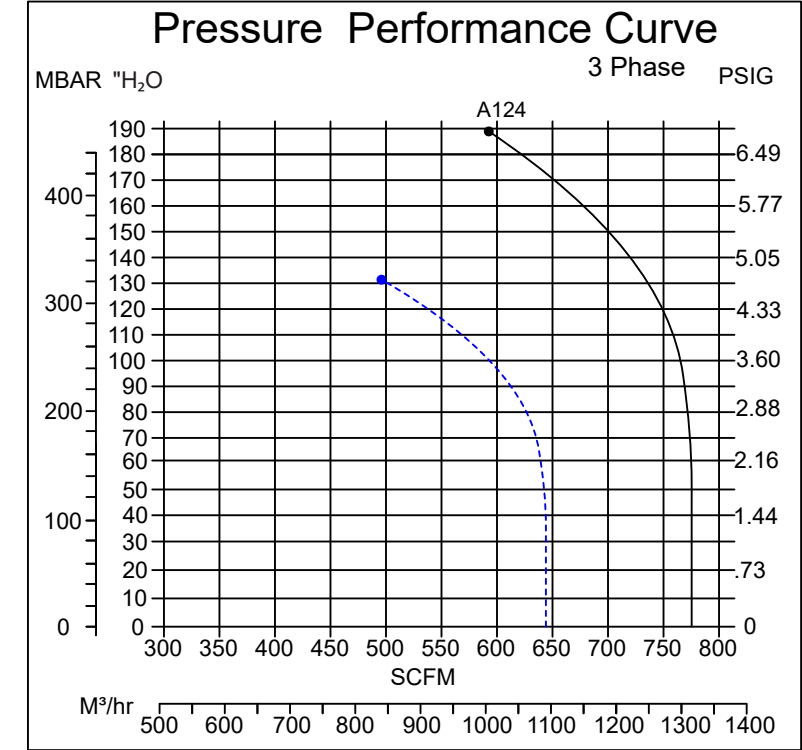
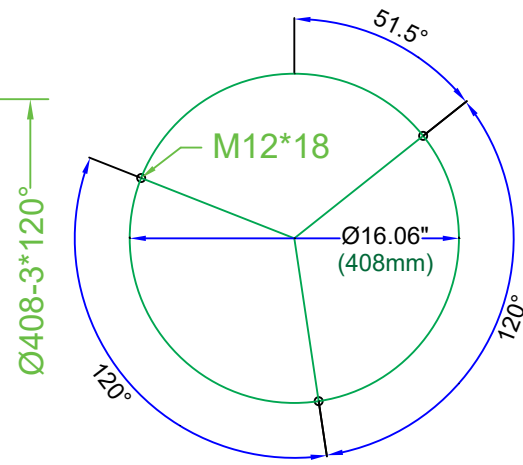

Disclaimer
 Ownership of this document and all accompanying information and data including but not limited to all applicable copyrights, trade secrets, patents and other intellectual property remain the property of Atlantic Blowers and are not to be copied, duplicated or reproduced, nor transmitted or disclosed to a third party without express written permission from Atlantic Blowers. Atlantic Blowers makes no representation or warranties, express or implied, with respect to the reuse of the data provided herewith, regardless of its format or the means of its transmission. The user accepts the data "as is", and assumes all risks associated with its use.