

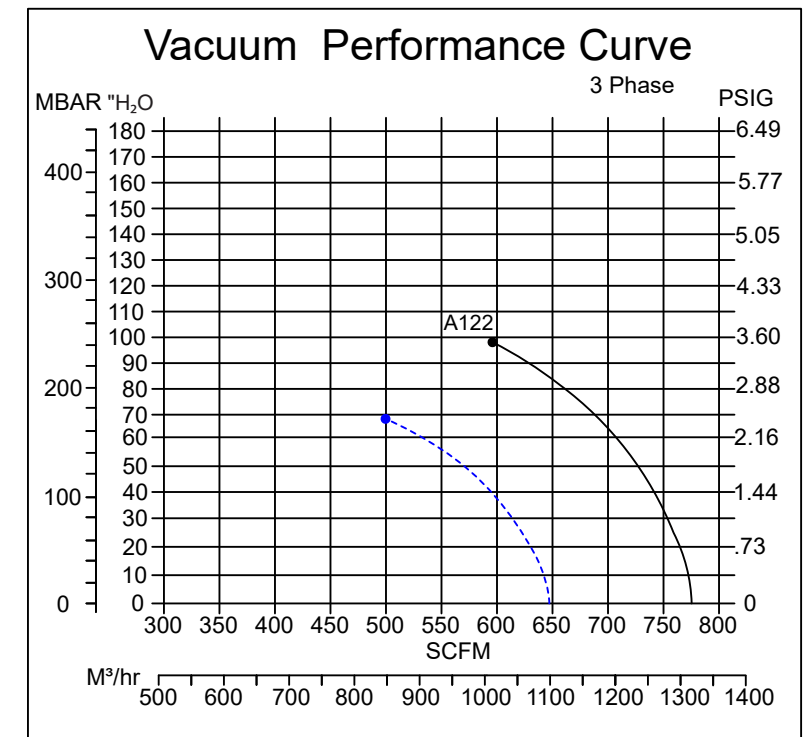

Phase	Model Number	Curve Number	Frequency (Hz)	KW	HP	Max Flow (SCFM)	Max Pressure ("H ₂ O)	Max Vacuum ("H ₂ O)	Sound Level (dB)	Inlet/Outlet Diameter (Inches)	Voltage	Current (A)	Weight (lbs)
3	AB-1302	A122	60Hz	15.50	20.00	776	87	99	81	2.50"	220-275/380-480	52.0Δ/30.0Y	309
			50Hz	12.90	16.67	647	60	69	77		200-240/345-415	43.3Δ/25.0Y	

MODEL NO. : AB-1302 DOUBLE STAGE

**Sound db measured at 3ft.

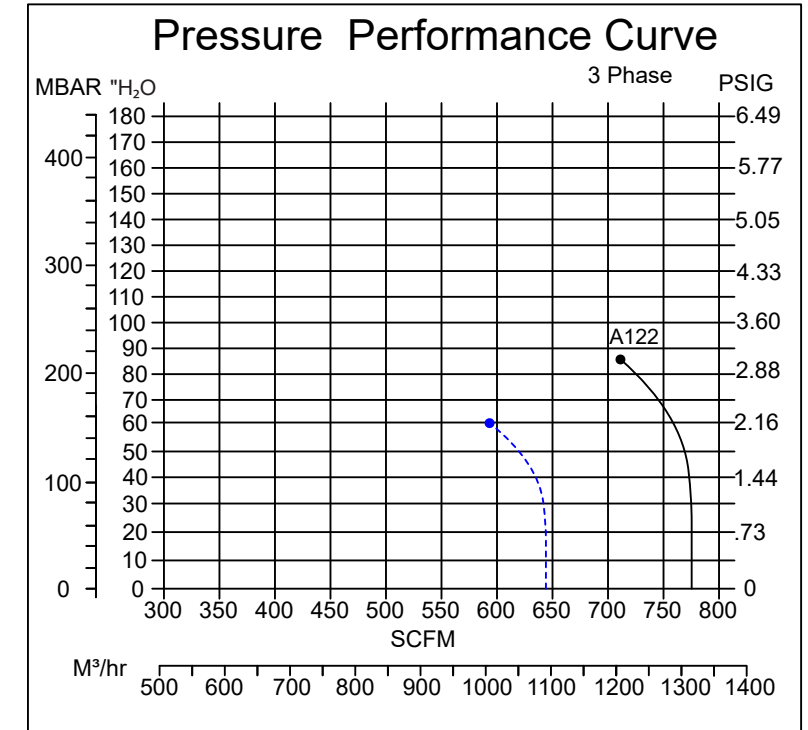
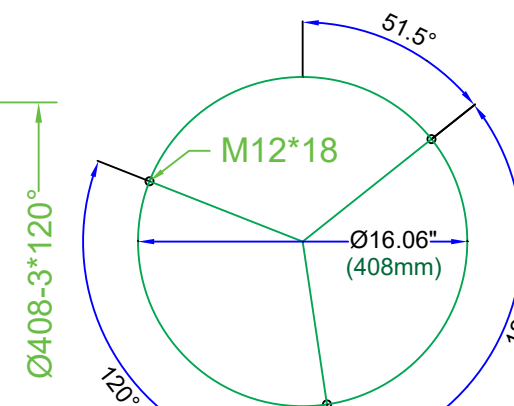
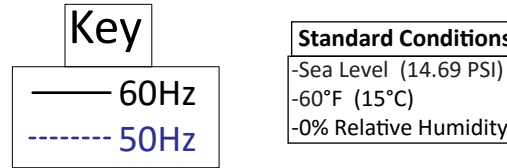
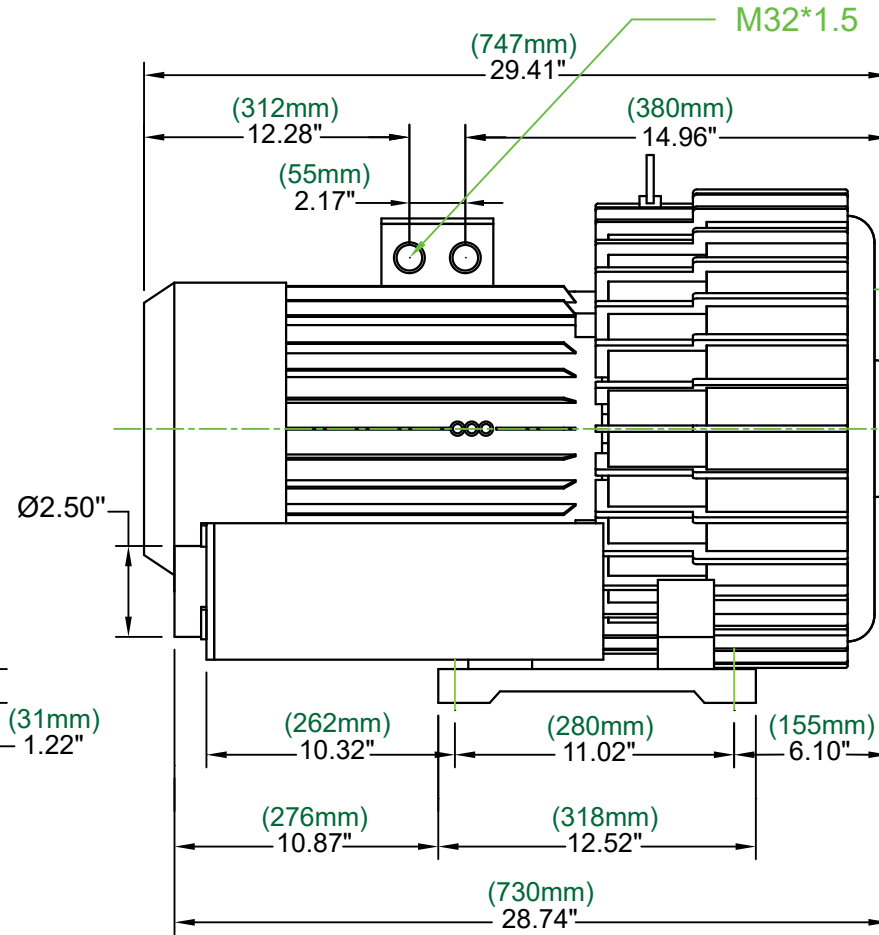
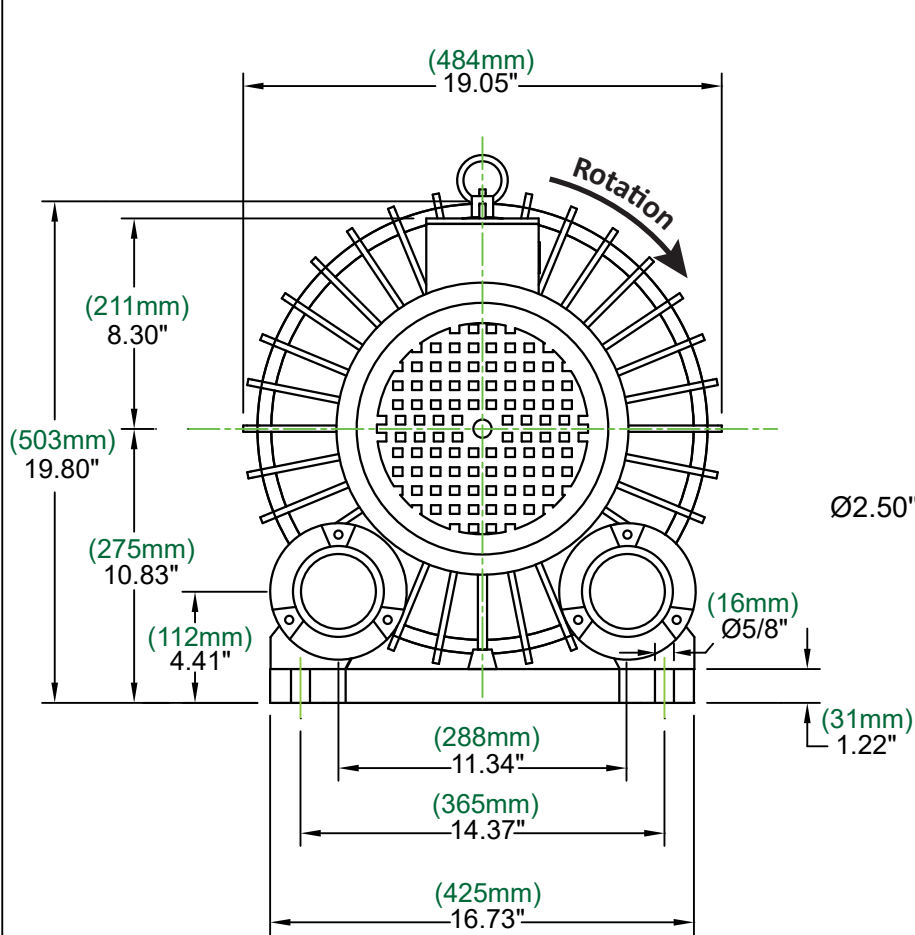

Pressure -Temperature Rise Curve

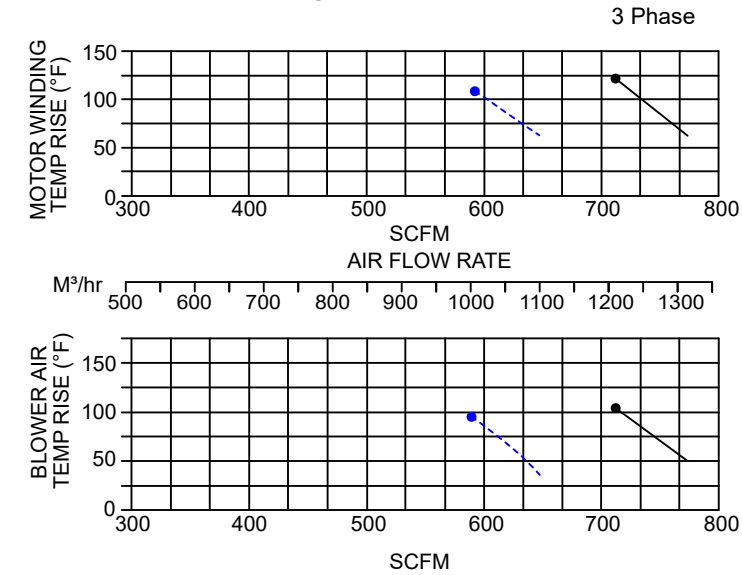

Vacuum -Temperature Rise Curve

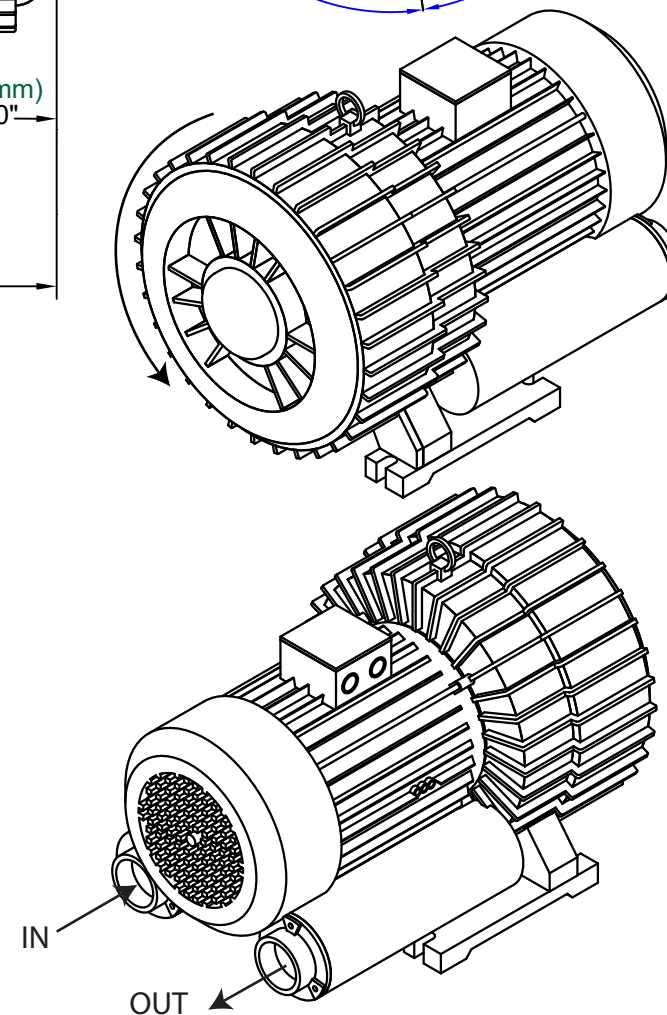
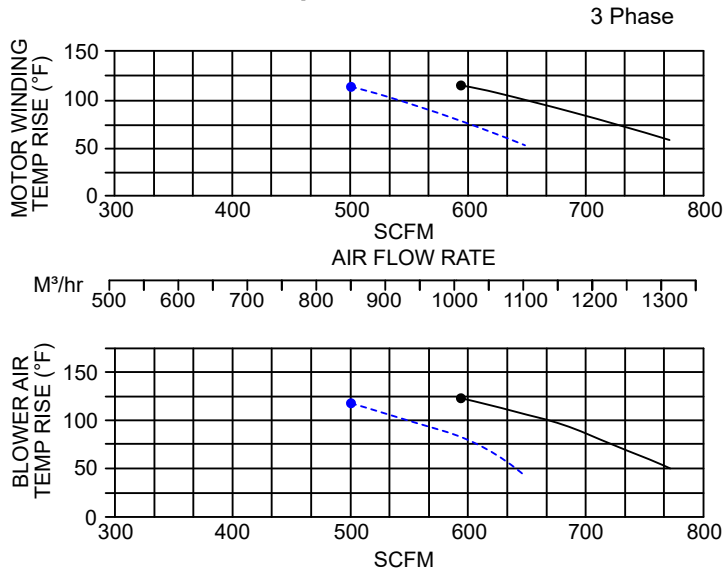

Disclaimer

Ownership of this document and all accompanying information and data including but not limited to all applicable copyrights, trade secrets, patents and other intellectual property remain the property of Atlantic Blowers and are not to be copied, duplicated or reproduced, nor transmitted or disclosed to a third party without express written permission from Atlantic Blowers. Atlantic Blowers makes no representation or warranties, express or implied, with respect to the reuse of the data provided herewith, regardless of its format or the means of its transmission. The user accepts the data "as is", and assumes all risks associated with its use.