

Water & Steam Monoflow

Catalog C2004
Water & Low Pressure Steam Monoflow

BC-54165 SERIES

Special Design Features

- **Two widely spaced Carbon Bearings provides greater support to the siphon pipe and hoses.**
- **Carbon Seal placed under compression add strength and shock resistance. Joints lasts longer.**
- **External seal wear indicator allows for planned maintenance reducing expensive downtime.**
- **All metal wear parts are bronze for excellent corrosion resistance.**

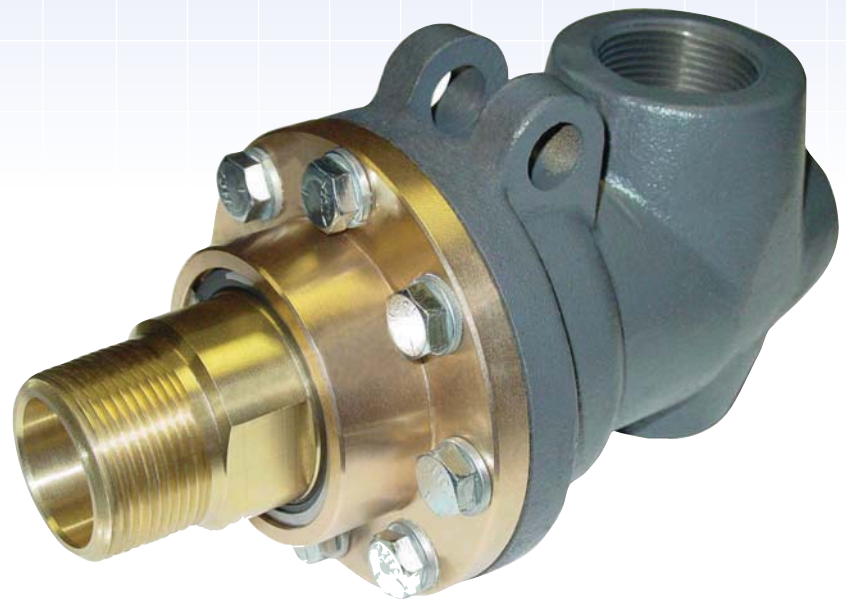

Sizes 1/2" to 3"

Type "CS" Bronze Trim Rotary Joints are ideal for a wide range of applications using low pressure steam & water. These joints feature an iron casing, bronze sleeve and end cap, stainless steel spring and spring guides.

The high density carbon seal under compression and widely spaced bearing surfaces assure exceptionally long service life without lubrication. A key maintenance feature is the external seal wear indicator.

Operating Parameters:

Temperature:	+353°F (+178°C)
Pressure Rating:	
Steam	125 psi (8.6 BAR)
Water	300 psi (20.6 BAR)

Engineered for Performance

TYPE "CS" & "CSF"



Bronze Trim Construction
 Bronze sleeve and end cap, with casing for water, brine and low pressure steam.
 Steam - 125 psi (8.6 BAR)
 Water - 300 psi (20.6 BAR)

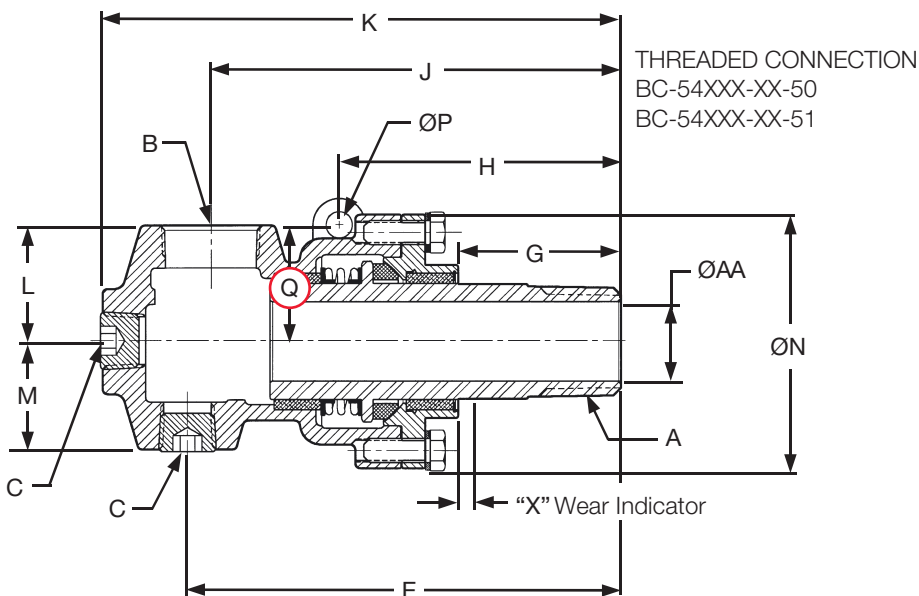

For BSPT threads:

Add a "B" to the end of the part number.

Example: BC-54165-08-50B

Joint Size	Bronze Trim Part Number	A NPT	B NPT	øAA	C NPT	E	G	H	J	K	L	M
1/2"	BC-54165-08-50	1/2" R.H.	1/2"	Ø.50"	1/4"	5.37"	1.73"	—	4.54"	5.87"	1.62"	1.16"
	BC-54165-08-51	1/2" L.H.	1/2"	Ø.50"	1/4"	5.37"	1.73"	—	4.54"	5.87"	1.62"	1.16"
3/4"	BC-54165-12-50	3/4" R.H.	3/4"	Ø.75"	1/2"	5.16"	1.68"	—	4.54"	6.17"	1.75"	1.25"
	BC-54165-12-51	3/4" L.H.	3/4"	Ø.75"	1/2"	5.16"	1.68"	—	4.54"	6.17"	1.75"	1.25"
1"	BC-54165-16-50	1" R.H.	1"	Ø1.00"	1/2"	5.96"	2.03"	4.01"	5.21"	7.01"	2.06"	1.25"
	BC-54165-16-51	1" L.H.	1"	Ø1.00"	1/2"	5.96"	2.03"	4.01"	5.21"	7.01"	2.06"	1.25"
	BC-54165-16-60	CF	1"	Ø1.00"	1/2"	6.69"	2.77"	4.75"	5.94"	7.75"	2.06"	1.25"
1 1/4"	BC-54165-20-50	1 1/4" R.H.	1 1/4"	Ø1.25"	3/4"	6.99"	1.89"	4.37"	6.68"	8.60"	2.19"	1.78"
	BC-54165-20-51	1 1/4" L.H.	1 1/4"	Ø1.25"	3/4"	6.99"	1.89"	4.37"	6.68"	8.60"	2.19"	1.78"
1 1/2"	BC-54165-24-50	1 1/2" R.H.	1 1/2"	Ø1.50"	3/4"	7.48"	2.12"	4.72"	7.04"	9.03"	2.44"	2.06"
	BC-54165-24-51	1 1/2" L.H.	1 1/2"	Ø1.50"	3/4"	7.48"	2.12"	4.72"	7.04"	9.03"	2.44"	2.06"
	BC-54165-24-60	CF	1 1/2"	Ø1.50"	3/4"	8.89"	3.53"	6.13"	8.45"	10.45"	2.44"	2.06"
2"	BC-54165-32-50	2" R.H.	2"	Ø1.88"	1 1/4"	8.62"	2.19"	5.01"	8.06"	10.63"	2.75"	2.56"
	BC-54165-32-51	2" L.H.	2"	Ø1.88"	1 1/4"	8.62"	2.19"	5.01"	8.06"	10.63"	2.75"	2.56"
	BC-54165-32-60	CF	2"	Ø1.88"	1 1/4"	10.09"	3.66"	6.48"	9.53"	12.10"	2.75"	2.56"
2 1/2"	BC-54165-40-50	2 1/2" R.H.	2 1/2"	Ø2.25"	1 1/4"	10.14"	2.91"	6.33"	9.76"	12.45"	3.00"	2.50"
	BC-54165-40-51	2 1/2" L.H.	2 1/2"	Ø2.25"	1 1/4"	10.14"	2.91"	6.33"	9.76"	12.45"	3.00"	2.50"
	BC-54165-40-60	CF	2 1/2"	Ø2.25"	1 1/4"	10.09"	3.66"	6.48"	9.53"	12.10"	3.00"	2.50"
3"	BC-54165-48-50	3" R.H.	3"	Ø2.88"	1 1/2"	10.86"	3.05"	6.60"	10.67"	13.04"	3.62"	2.88"
	BC-54165-48-51	3" L.H.	3"	Ø2.88"	1 1/2"	10.86"	3.05"	6.60"	10.67"	13.04"	3.62"	2.88"
	BC-54165-48-60	CF	3"	Ø2.88"	1 1/2"	11.35"	3.55"	7.10"	11.16"	13.53"	3.62"	2.88"

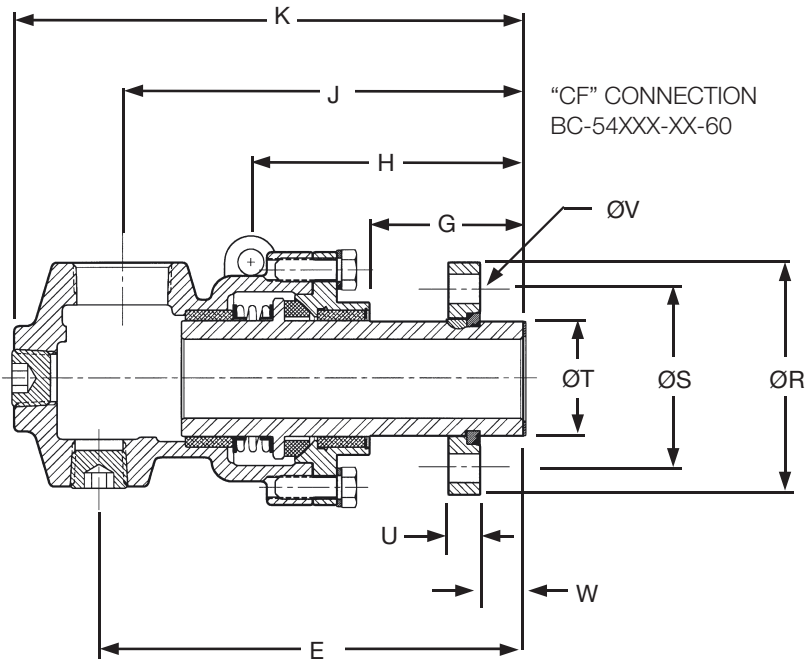

ØN	ØP	Torque Rod O.D. Max.	Q	ØR	ØS	ØT	U	4X ØV	W	"X"	Weight	Joint Size
Ø3.00"	—	—	—	—	—	—	—	—	—	.19"	3.5 lbs	1/2"
Ø3.00"	—	—	—	—	—	—	—	—	—	.19"	3.5 lbs	
Ø3.38"	—	—	—	—	—	—	—	—	—	.19"	5 lbs.	3/4"
Ø3.38"	—	—	—	—	—	—	—	—	—	.19"	5 lbs.	
Ø3.62"	Ø.50"	Ø.38"	1.75"	—	—	—	—	—	—	.25"	6 lbs.	1"
Ø3.62"	Ø.50"	Ø.38"	1.75"	—	—	—	—	—	—	.25"	6 lbs.	
Ø3.62"	Ø.50"	Ø.38"	1.75"	Ø3.88"	Ø2.75"	Ø1.399"-1.401"	.75"	Ø.56"	1.092"	.25"	9 lbs.	
Ø4.38"	Ø.62"	Ø.50"	2.09"	—	—	—	—	—	—	.25"	13 lbs	1 1/4"
Ø4.38"	Ø.62"	Ø.50"	2.09"	—	—	—	—	—	—	.25"	13 lbs	
Ø4.75"	Ø.62"	Ø.50"	2.26"	—	—	—	—	—	—	.25"	15 lbs	1 1/2"
Ø4.75"	Ø.62"	Ø.50"	2.26"	—	—	—	—	—	—	.25"	15 lbs	
Ø4.75"	Ø.62"	Ø.50"	2.26"	Ø4.88"	Ø3.62"	Ø2.091"-2.093"	.75"	Ø.69"	1.092"	.25"	19 lbs	
Ø6.00"	Ø.62"	Ø.50"	2.76"	—	—	—	—	—	—	.31"	26 lbs	2"
Ø6.00"	Ø.62"	Ø.50"	2.76"	—	—	—	—	—	—	.31"	26 lbs	
Ø6.00"	Ø.62"	Ø.50"	2.76"	Ø5.50"	Ø4.25"	Ø2.714"-2.716"	.75"	Ø.69"	1.092"	.31"	31 lbs	
Ø6.75"	Ø.75"	Ø.62"	3.06"	—	—	—	—	—	—	.25"	33 lbs.	2 1/2"
Ø6.75"	Ø.75"	Ø.62"	3.06"	—	—	—	—	—	—	.25"	33 lbs.	
Ø6.75"	Ø.75"	Ø.62"	3.06"	Ø5.88"	Ø4.62"	Ø3.089"-3.091"	.75"	Ø.75"	1.092"	.25"	40 lbs	
Ø7.88"	Ø.94"	Ø.75"	3.62"	—	—	—	—	—	—	.25"	45 lbs.	3"
Ø7.88"	Ø.94"	Ø.75"	3.62"	—	—	—	—	—	—	.25"	45 lbs.	
Ø7.88"	Ø.94"	Ø.75"	3.62"	Ø6.50"	Ø5.25"	Ø3.714"-3.716"	.75"	Ø.69"	1.092"	.25"	50 lbs	

CF Connection

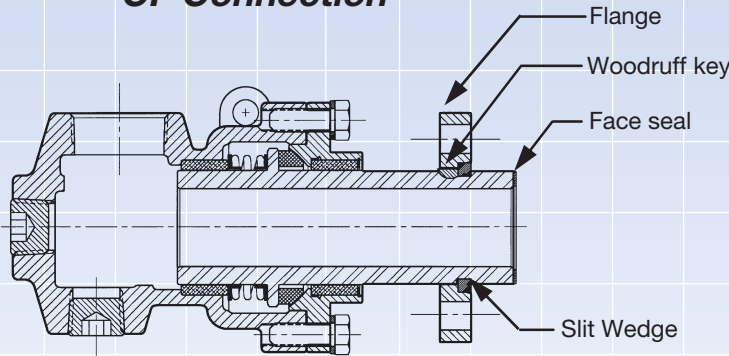

Journal Dimensions

Joint size	CF Connection	
	ØA	B
1"	Ø1.408"-1.406"	1.052"
1 1/2"	Ø2.099"-2.096"	1.052"
2"	Ø2.724"-2.721"	1.052"
2 1/2"	Ø3.099"-3.096"	1.052"
3"	Ø3.724"-3.721"	1.052"

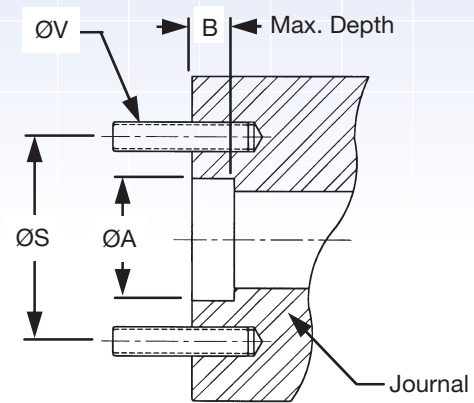

Repair Kits

Joint Size	Part Number
1/2"	10-27274-00
3/4"	10-27275-00
1"	10-27276-00
1 1/4"	10-27277-00
1 1/2"	10-27278-00
2"	10-27279-00
2 1/2"	10-27280-00
3"	10-27281-00

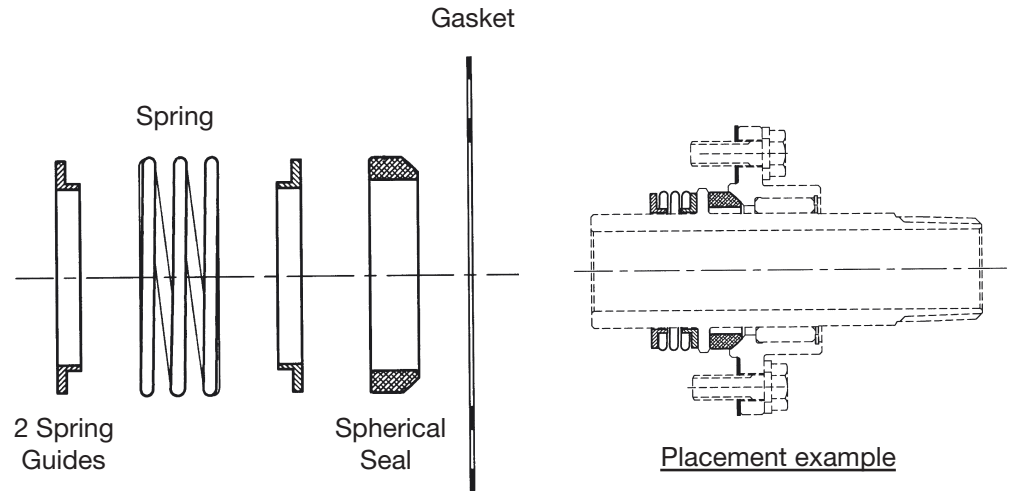

DEUBLIN Company
2050 Norman Drive
Waukegan, IL 60085-6747 U.S.A.

Phone: +1 847 689-8600

Fax: +1 847 689-8690

E-Mail: customerservice@deublin.com