

# Steam Duoflow Fixed Siphon

Catalog C2001  
High Pressure Steam Duoflow Fixed Siphon

## BC-54000 SERIES

### Special Design Features

- **Two widely spaced Carbon Bearings provides greater support to the siphon pipe and hoses.**
- **Carbon Seal placed under compression add strength and shock resistance. Joints lasts longer.**
- **External seal wear indicator allows for planned maintenance reducing expensive downtime.**
- **Hardened sleeve and nickel plated end cap provide exceptional life at high pressure.**



Sizes 1/2" to 3"

Type "C" Ferrrous Trim Rotary Joints are ideal for a wide range of applications using steam. These joints feature an iron casing, ferrous sleeve and end cap, stainless steel spring and spring guides.

The high density carbon seal under compression and widely spaced bearing surfaces assure exceptionally long service life without lubrication. A key maintenance feature is the external seal wear indicator.

#### Operating Parameters:

Temperature:	+406°F (+208°C)
Pressure Rating:	
Sizes 1/2" to 1-1/2"	250 psi (17.2 BAR)
Sizes 2" to 3"	225 psi (15.5 BAR)

**Engineered for Performance**

# TYPE "C" & "CF"



Ferrous Trim Construction  
Recommended for higher pressure steam  
to 250 psi (17.2 BAR)

For BSPT threads:

Add a "B" to the end of the part number.

Example: BC-54000-08-50B

\*BSPT Models are not supplied with siphon bushing

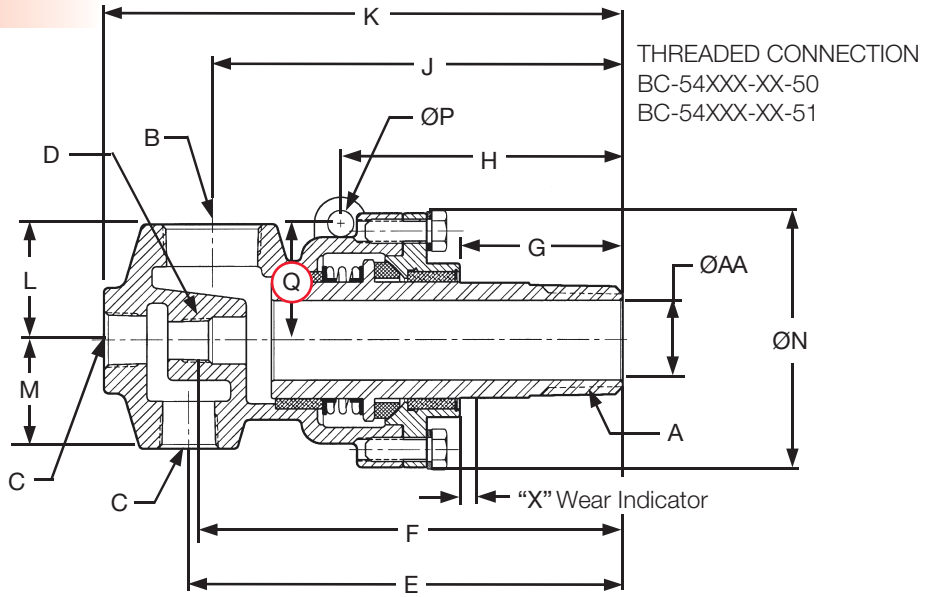

Joint Size	Ferrous Trim Part Number	A NPT	B NPT	øAA	C NPT	D Siphon Thread NPT	D Siphon Thd With Bushing*	E	F	G	H	J	K
1/2"	BC-54000-08-50	1/2" R.H.	1/2"	Ø.50"	1/4"	1/8"	—	5.37"	5.06"	1.73"	—	4.54"	5.87"
	BC-54000-08-51	1/2" L.H.	1/2"	Ø.50"	1/4"	1/8"	—	5.37"	5.06"	1.73"	—	4.54"	5.87"
3/4"	BC-54000-12-50	3/4" R.H.	3/4"	Ø.75"	1/2"	1/4"	1/8"	5.16"	5.25"	1.68"	—	4.54"	6.17"
	BC-54000-12-51	3/4" L.H.	3/4"	Ø.75"	1/2"	1/4"	1/8"	5.16"	5.25"	1.68"	—	4.54"	6.17"
1"	BC-54000-16-50	1" R.H.	1"	Ø1.00"	1/2"	3/8"	1/4"	5.96"	6.04"	2.03"	4.01"	5.21"	7.01"
	BC-54000-16-51	1" L.H.	1"	Ø1.00"	1/2"	3/8"	1/4"	5.96"	6.04"	2.03"	4.01"	5.21"	7.01"
	BC-54000-16-60	CF	1"	Ø1.00"	1/2"	3/8"	1/4"	6.69"	6.78"	2.77"	4.75"	5.94"	7.75"
	BC-54000-16-62	QR	1"	Ø1.00"	1/2"	3/8"	1/4"	6.70"	6.79"	2.78"	4.76"	5.95"	7.76"
1 1/4"	BC-54000-20-50	1 1/4" R.H.	1 1/4"	Ø1.25"	3/4"	1/2"	3/8"	6.99"	7.25"	1.89"	4.37"	6.68"	8.60"
	BC-54000-20-51	1 1/4" L.H.	1 1/4"	Ø1.25"	3/4"	1/2"	3/8"	6.99"	7.25"	1.89"	4.37"	6.68"	8.60"
	BC-54000-20-62	QR	1 1/4"	Ø1.25"	3/4"	1/2"	3/8"	8.55"	8.81"	3.45"	5.93"	8.24"	10.16"
1 1/2"	BC-54000-24-50	1 1/2" R.H.	1 1/2"	Ø1.50"	3/4"	3/4"	1/2"	7.48"	7.53"	2.12"	4.72"	7.04"	9.03"
	BC-54000-24-51	1 1/2" L.H.	1 1/2"	Ø1.50"	3/4"	3/4"	1/2"	7.48"	7.53"	2.12"	4.72"	7.04"	9.03"
	BC-54000-24-60	CF	1 1/2"	Ø1.50"	3/4"	3/4"	1/2"	8.89"	8.94"	3.53"	6.13"	8.45"	10.45"
	BC-54000-24-62	QR	1 1/2"	Ø1.50"	3/4"	3/4"	1/2"	8.89"	8.94"	3.53"	6.13"	8.45"	10.45"
2"	BC-54000-32-50	2" R.H.	2"	Ø1.88"	1 1/4"	3/4"	1/2"	8.62"	8.62"	2.19"	5.01"	8.06"	10.63"
	BC-54000-32-51	2" L.H.	2"	Ø1.88"	1 1/4"	3/4"	1/2"	8.62"	8.62"	2.19"	5.01"	8.06"	10.63"
	BC-54000-32-60	CF	2"	Ø1.88"	1 1/4"	3/4"	1/2"	10.09"	10.08"	3.66"	6.48"	9.53"	12.10"
	BC-54000-32-62	QR	2"	Ø1.88"	1 1/4"	3/4"	1/2"	9.71"	9.71"	3.28"	6.10"	9.15"	11.72"
2 1/2"	BC-54000-40-50	2 1/2" R.H.	2 1/2"	Ø2.25"	1 1/4"	1"	3/4"	10.14"	10.24"	2.91"	6.33"	9.76"	12.45"
	BC-54000-40-51	2 1/2" L.H.	2 1/2"	Ø2.25"	1 1/4"	1"	3/4"	10.14"	10.24"	2.91"	6.33"	9.76"	12.45"
	BC-54000-40-60	CF	2 1/2"	Ø2.25"	1 1/4"	1"	3/4"	10.09"	10.56"	3.66"	6.48"	9.53"	12.10"
	BC-54000-40-62	QR	2 1/2"	Ø2.25"	1 1/4"	1"	3/4"	10.77"	10.86"	3.54"	6.96"	10.39"	13.08"
3"	BC-54000-48-50	3" R.H.	3"	Ø2.88"	1 1/2"	1 1/2"	1"	10.86"	11.03"	3.05"	6.60"	10.67"	13.04"
	BC-54000-48-51	3" L.H.	3"	Ø2.88"	1 1/2"	1 1/2"	1"	10.86"	11.03"	3.05"	6.60"	10.67"	13.04"
	BC-54000-48-60	CF	3"	Ø2.88"	1 1/2"	1 1/2"	1"	11.35"	11.53"	3.55"	7.10"	11.16"	13.53"
	BC-54000-48-62	QR	3"	Ø2.88"	1 1/2"	1 1/2"	1"	11.36"	11.53"	3.55"	7.10"	11.16"	13.54"

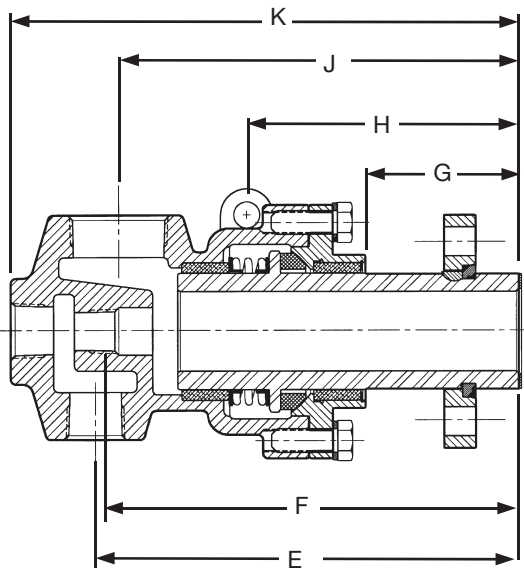

"CF" CONNECTION  
BC-54XXX-XX-60

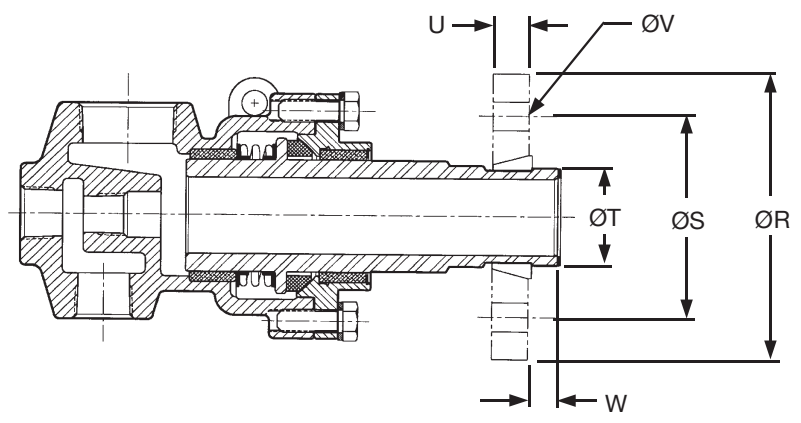

QUICK RELEASE CONNECTION  
BC-54XXX-XX-62

L	M	ØN	ØP	Torque Rod O.D. Max.	Q	ØR	ØS	ØT	U	4X ØV	W	"X"	Weight	Joint Size
1.62"	1.16"	Ø3.00"	—	—	—	—	—	—	—	—	—	.19"	3.5 lbs	1/2"
1.62"	1.16"	Ø3.00"	—	—	—	—	—	—	—	—	—	.19"	3.5 lbs	
1.75"	1.25"	Ø3.38"	—	—	—	—	—	—	—	—	—	.19"	5 lbs.	3/4"
1.75"	1.25"	Ø3.38"	—	—	—	—	—	—	—	—	—	.19"	5 lbs.	
2.06"	1.25"	Ø3.62"	Ø.50"	Ø.38"	1.75"	—	—	—	—	—	—	.25"	6 lbs.	1"
2.06"	1.25"	Ø3.62"	Ø.50"	Ø.38"	1.75"	—	—	—	—	—	—	.25"	6 lbs.	
2.06"	1.25"	Ø3.62"	Ø.50"	Ø.38"	1.75"	Ø3.88"	Ø2.75"	Ø1.399"-1.401"	.75"	Ø.56"	1.092"	.25"	9 lbs.	
2.06"	1.25"	Ø3.62"	Ø.50"	Ø.38"	1.75"	Ø5.00"	Ø3.12"	Ø1.276"-1.278"	.56"	Ø.56"	.438"	.25"	9 lbs.	
2.19"	1.78"	Ø4.38"	Ø.62"	Ø.50"	2.09"	—	—	—	—	—	—	.25"	13 lbs	1 1/4"
2.19"	1.78"	Ø4.38"	Ø.62"	Ø.50"	2.09"	—	—	—	—	—	—	.25"	13 lbs	
2.19"	1.78"	Ø4.38"	Ø.62"	Ø.50"	2.09"	Ø5.50"	Ø3.50"	Ø1.620"-1.622"	.62"	Ø.56"	.50"	.25"	18 lbs.	
2.44"	2.06"	Ø4.75"	Ø.62"	Ø.50"	2.26"	—	—	—	—	—	—	.25"	15 lbs	1 1/2"
2.44"	2.06"	Ø4.75"	Ø.62"	Ø.50"	2.26"	—	—	—	—	—	—	.25"	15 lbs	
2.44"	2.06"	Ø4.75"	Ø.62"	Ø.50"	2.26"	Ø4.88"	Ø3.62"	Ø2.091"-2.093"	.75"	Ø.69"	1.092"	.25"	19 lbs	
2.44"	2.06"	Ø4.75"	Ø.62"	Ø.50"	2.26"	Ø5.50"	Ø3.88"	Ø1.872"-1.870"	.69"	Ø.56"	.50"	.25"	19 lbs.	
2.75"	2.56"	Ø6.00"	Ø.62"	Ø.50"	2.76"	—	—	—	—	—	—	.31"	26 lbs	2"
2.75"	2.56"	Ø6.00"	Ø.62"	Ø.50"	2.76"	—	—	—	—	—	—	.31"	26 lbs	
2.75"	2.56"	Ø6.00"	Ø.62"	Ø.50"	2.76"	Ø5.50"	Ø4.25"	Ø2.714"-2.716"	.75"	Ø.69"	1.092"	.31"	31 lbs	
2.75"	2.56"	Ø6.00"	Ø.62"	Ø.50"	2.76"	Ø6.81"	Ø4.75"	Ø2.318"-2.320"	.75"	Ø.56"	.625"	.31"	34 lbs.	
3.00"	2.50"	Ø6.75"	Ø.75"	Ø.62"	3.06"	—	—	—	—	—	—	.25"	33 lbs.	2 1/2"
3.00"	2.50"	Ø6.75"	Ø.75"	Ø.62"	3.06"	—	—	—	—	—	—	.25"	33 lbs.	
3.00"	2.50"	Ø6.75"	Ø.75"	Ø.62"	3.06"	Ø5.88"	Ø4.62"	Ø3.089"-3.091"	.75"	Ø.75"	1.092"	.25"	40 lbs	
3.00"	2.50"	Ø6.75"	Ø.75"	Ø.62"	3.06"	Ø6.75"	Ø4.75"	Ø2.838"-2.840"	.88"	Ø.56"	.75"	.25"	42 lbs.	
3.62"	2.88"	Ø7.88"	Ø.94"	Ø.75"	3.62"	—	—	—	—	—	—	.25"	45 lbs.	3"
3.62"	2.88"	Ø7.88"	Ø.94"	Ø.75"	3.62"	—	—	—	—	—	—	.25"	45 lbs.	
3.62"	2.88"	Ø7.88"	Ø.94"	Ø.75"	3.62"	Ø6.50"	Ø5.25"	Ø3.714"-3.716"	.75"	Ø.69"	1.092"	.25"	50 lbs	
3.62"	2.88"	Ø7.88"	Ø.94"	Ø.75"	3.62"	Ø8.00"	Ø6.75"	Ø3.430"-3.732"	.94"	Ø.69"	.88"	.25"	57 lbs.	

**CF Connection**

BC-54XXX-XX-60

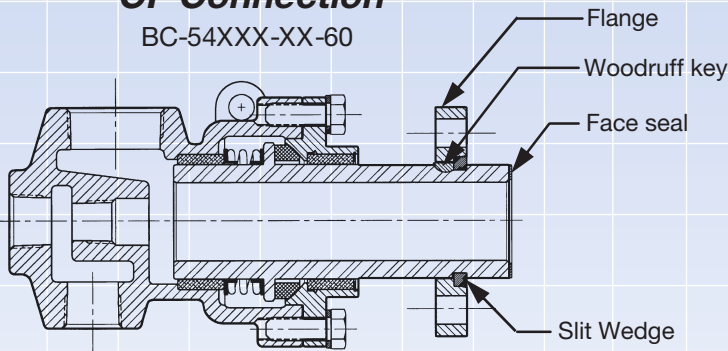

**Quick Release Connection**

BC-54XXX-XX-62

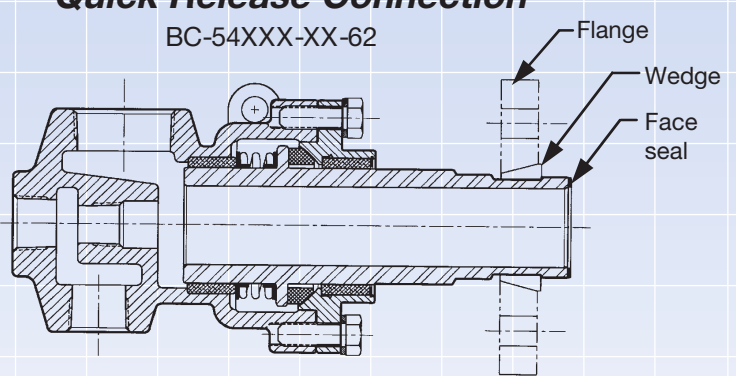

**Journal Dimensions**

Joint size	CF Connection		Quick Release Connection	
	ØA	B	ØA	B
1"	Ø1.408"-1.406"	1.052"	Ø1.283"-1.279"	.312"
1 1/4"	--	1.052"	Ø1.624"-1.623"	.375"
1 1/2"	Ø2.099"-2.096"	1.052"	Ø1.877"-1.873"	.375"
2"	Ø2.724"-2.721"	1.052"	Ø2.325"-2.321"	.500"
2 1/2"	Ø3.099"-3.096"	1.052"	Ø2.845"-2.841"	.625"
3"	Ø3.724"-3.721"	1.052"	Ø3.439"-3.435"	.875"

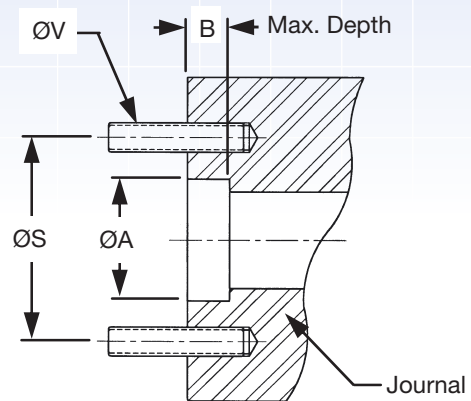

Quick Release Flanges and split wedges are available. Contact DEUBLIN for more information.

**Repair Kits**

Joint Size	Part Number
1/2"	10-27274-00
3/4"	10-27275-00
1"	10-27276-00
1 1/4"	10-27277-00
1 1/2"	10-27278-00
2"	10-27279-00
2 1/2"	10-27280-00
3"	10-27281-00

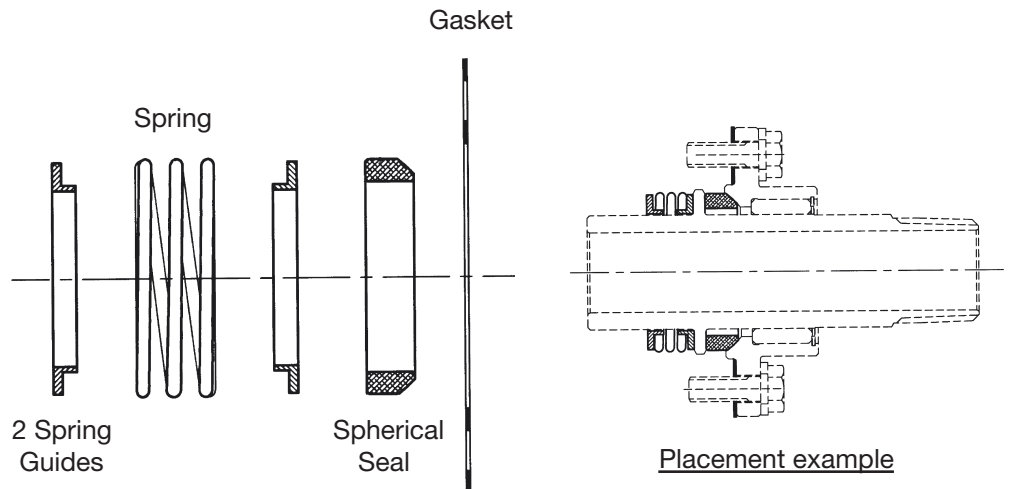

DEUBLIN Company  
 2050 Norman Drive  
 Waukegan, IL 60085-6747 U.S.A.  
 Phone: +1 847 689-8600  
 Fax: +1 847 689-8690  
 E-Mail: customerservice@deublin.com