

# T31 Type

## Full Spacer Horizontal Split Aluminium Cover

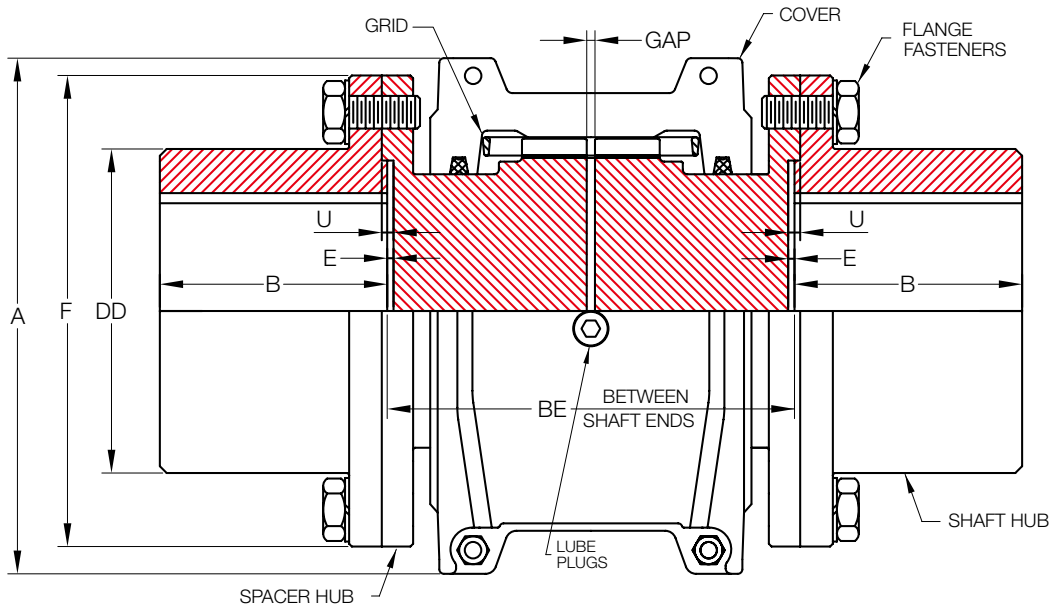

Size	Torque Rating (Nm)	Allow Speed RPM	Max Bore (mm)	Min Bore (mm)	Cplg Weight (Kg)	Add BE Weight (Kg)	Lube Weight (Kg)	Dimensions (Millimeters)									Flange Fasteners	
								A	B	BE		DD	E	F	U	GAP	No. per Flange	Dia (mm)
										Min	Max							
1020	52	4,500	35	13	3.85	0.010	0.0272	101.0	34.9	88.9	203	52.4	0.8	85.7	1.8	5	4	6.3
1030	149	4,500	43	13	5.21	0.016	0.0408	109.0	41.3	88.9	216	59.5	0.8	93.7	1.8	5	8	6.3
1040	249	4,500	56	13	8.43	0.021	0.0544	116.0	54.0	88.9	216	78.6	0.8	112.7	1.8	5	8	6.3
1050	435	4,500	67	13	12.80	0.028	0.0680	137.8	60.3	111.1	216	87.3	0.8	125.4	1.8	5	8	7.9
1060	684	4,350	80	20	20.50	0.037	0.0862	147.0	73.0	122.2	330	103.2	1.8	144.5	2.8	5	8	9.5
1070	994	4,125	85	20	24.80	0.048	0.1130	162.2	79.4	127.0	330	109.5	1.8	152.4	2.8	5	12	9.5
1080	2,050	3,600	95	27	40.00	0.069	0.1720	193.0	88.9	155.5	406	122.2	1.8	177.8	2.8	5	12	12.7
1090	3,730	3,600	110	27	60.10	0.100	0.2540	212.0	101.6	163.5	406	142.9	1.8	209.6	2.8	5	12	15.8
1100	6,280	2,440	130	39	90.20	0.120	0.4260	250.7	90.4	203.2	406	171.4	1.6	250.8	3.2	6	12	19.0
1110	9,320	2,250	150	51	119.00	0.160	0.5080	270.0	104.1	209.6	406	196.8	1.6	276.2	3.2	6	12	19.0
1120	13,700	2,025	170	64	178.00	0.200	0.7350	306.4	119.4	246.1	406	225.4	1.6	319.1	4.0	10	12	22.2
1130	19,900	1,800	190	77	237.00	0.290	0.9070	343.8	134.6	257.1	406	238.1	1.6	346.1	4.0	10	12	25.4
1140	28,600	1,650	210	89	327.00	0.400	1.1300	383.8	152.4	266.7	406	266.7	1.6	385.8	4.0	10	12	28.5
1150	39,800	1,500	270	102	462.00	0.190	1.9500	453.1	172.7	344.5	371.3	334.3	5.1	425.4	-	10	14	22.2
1160	55,900	1,350	290	115	566.00	0.250	2.8100	501.4	186.4	355.6	406.4	366.0	6.6	457.2	-	10	14	22.2
1170	74,600	1,225	340	127	856.00	0.380	3.4900	566.4	220.2	384.2	444.5	424.9	8.4	527.0	-	10	16	25.4
1180	103,000	1,100	340	102	1,135.00	0.470	3.7600	629.9	248.9	400.1	490.5	450.8	5.1	590.6	8.1	10	16	28.5
1190	137,000	1,050	380	115	1,525.00	0.600	4.4000	675.6	275.8	411.2	530.4	508.0	5.1	660.4	8.1	10	18	31.7
1200	186,000	900	400	127	1,910.00	0.850	5.6200	756.9	305.3	444.5	574.5	530.4	6.1	711.2	9.1	10	18	31.7

\* Min BE Weight is Added Weight per Millimeters of BE over Minimum  
 \* Coupling Weight is with no Bore and Minimum BE