

T10 Type (Large)

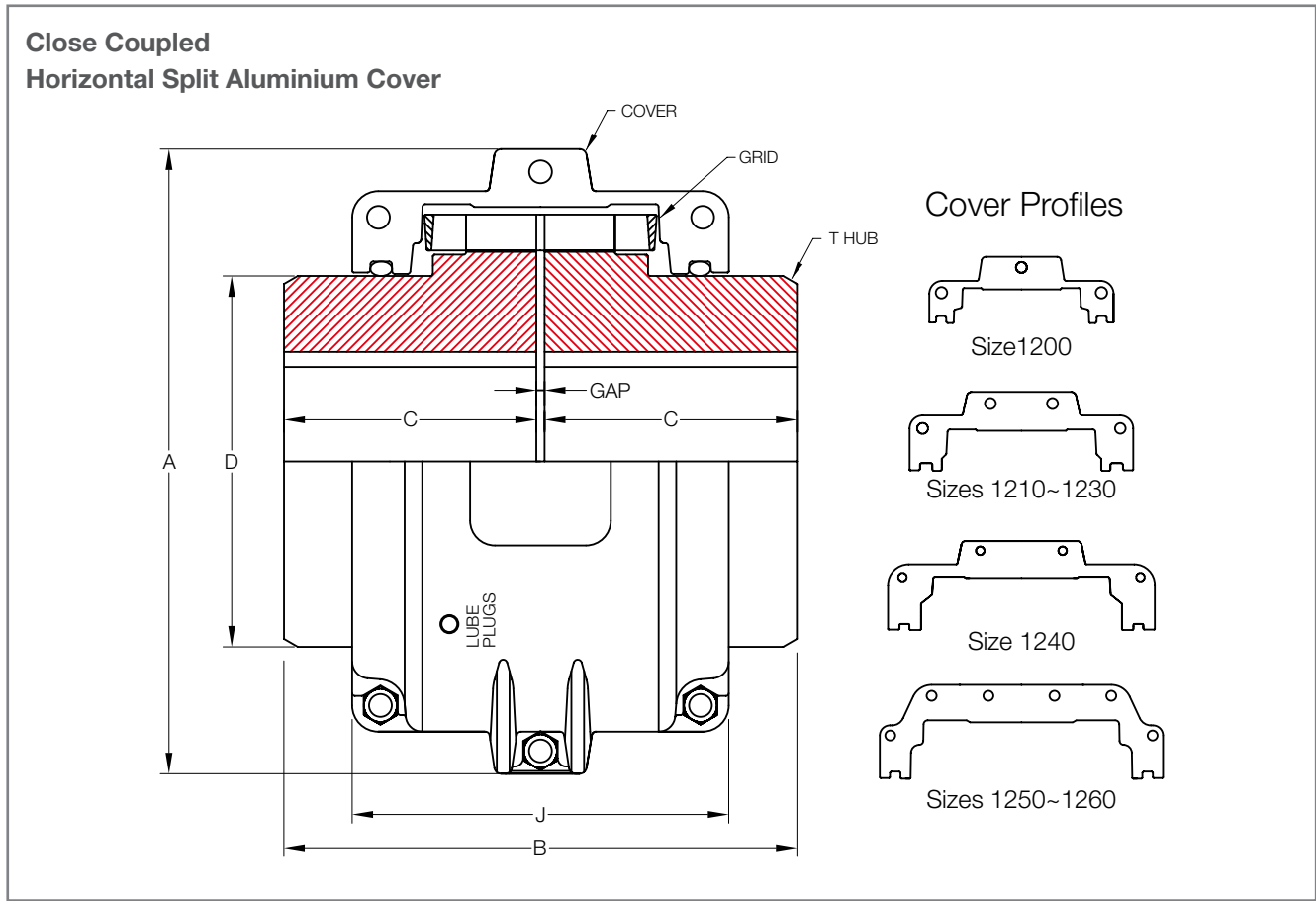

Size	Torque Rating (Nm)	Allow Speed RPM	Max Bore (mm)	Min Bore (mm)	Cplg Weight (Kg)	Lube Weight (Kg)	Dimensions (Millimeters)						Size
							A	B	C	D	J	GAP	
1150	39,800	1,500	215	108	234	1.95	453.1	371.8	182.9	269.2	271.5	6	1150
1160	55,900	1,350	240	121	317	2.81	501.9	402.2	198.1	304.8	278.4	6	1160
1170	74,600	1,225	280	134	448	3.49	566.9	437.8	215.9	355.6	307.3	6	1170
1180	103,000	1,100	300	153	619	3.76	629.9	483.6	238.8	393.7	321.1	6	1180
1190	137,000	1,050	335	153	776	4.40	675.6	524.2	259.1	436.9	325.1	6	1190
1200	186,000	900	360	178	1058	5.62	756.9	564.8	279.4	497.8	355.6	6	1200
1210	249,000	820	390	178	1424	10.50	844.6	622.6	304.8	533.4	431.8	13	1210
1220	336,000	730	420	203	1785	16.10	920.8	663.2	325.1	571.5	490.2	13	1220
1230	435,000	680	450	203	2267	24.00	1,003.3	703.8	345.4	609.6	546.1	13	1230
1240	559,000	630	480	254	2950	33.80	1,087.1	749.6	368.3	647.7	647.7	13	1240
1250	746,000	580	-	254	3833	50.10	1,181.1	815.6	401.3	711.2	698.5	13	1250
1260	932,000	540	-	254	4682	67.20	1,260.9	876.6	431.8	762.0	762.0	13	1260

* Coupling Weight is without Bore Machining