

KD Type

Standard Type

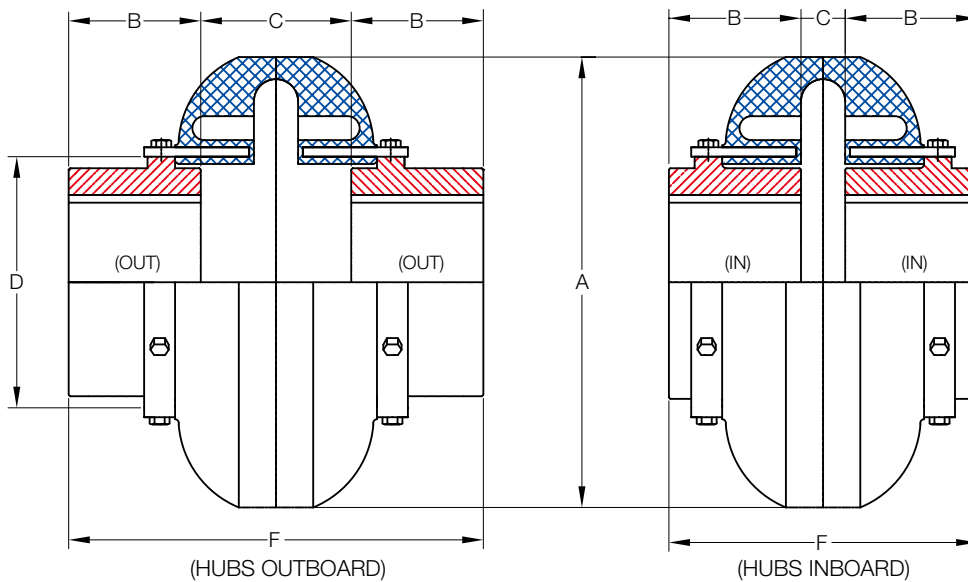

Size	Torque Rating (Nm)	Allow Speed RPM	Power Rating (kW)	Cplg Weight (Kg)	Max Bore (mm)	Min Bore (mm)	Dimensions (Millimeters)						
							A	B	C (Gap)		D	F	
									In	Out		In	Out
2	21.5	7,500	0.0023	0.55	28	13	89	24	35	47	47	83	95
3	41.2	7,500	0.0043	1.10	34	13	102	37	9	47	59	83	121
4	62.0	7,500	0.0066	1.40	42	13	116	37	9	47	66	83	121
5	108.0	7,500	0.0110	2.50	48	13	137	45	10	52	80	100	142
10	163.8	7,500	0.0170	3.70	55	13	162	45	11	53	93	101	143
20	260.0	6,600	0.0270	5.90	60	21	184	50	15	63	114	115	163
30	412.0	5,800	0.0430	9.60	75	21	210	56	12	68	138	124	180
40	622.0	5,000	0.0660	15.90	85	26	241	61	12	74	168	134	196
50	864.0	4,200	0.0900	24.50	90	26	279	69	12	86	207	150	224
60	1,412.0	3,800	0.1480	32.80	105	31	318	80	11	99	222	171	259
70	2,486.0	3,600	0.2620	39.00	120	31	356	85	18	109	235	189	281
80	4,463.0	2,000	0.4670	77.00	155	31	406	114	17	147	286	245	377
100	9,605.0	1,900	1.0000	111.00	171	48	533	140	44	95	359	324	375
120	19,221.0	1,800	2.0000	193.00	190	48	635	152	57	124	448	362	429

* Coupling Weight is without Bore Machining