

# KSP Type

## Standard Flanged Sleeve Spacer

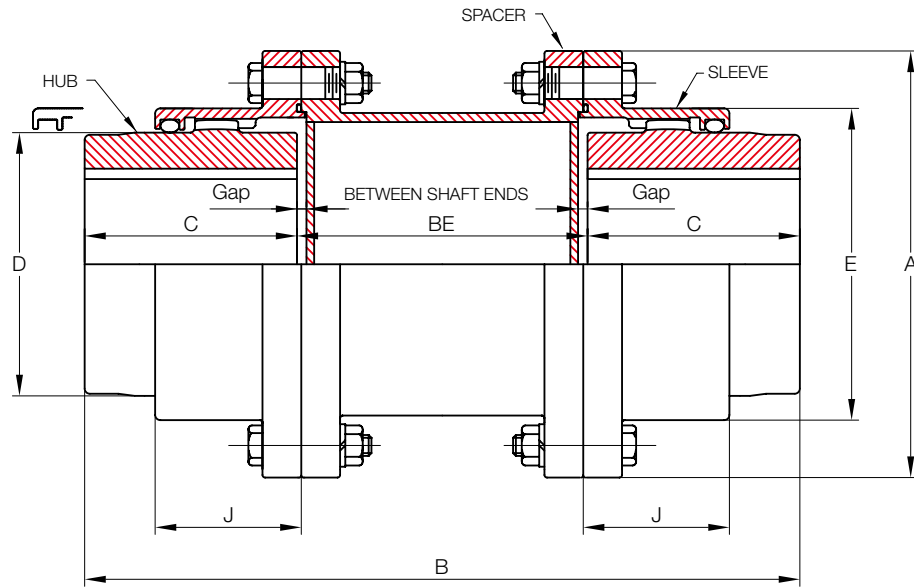

Size	Torque Rating (Nm)	Allow Speed RPM	Max Bore (mm)	Min Bore (mm)	Lube Weight (Kg)	Dimensions (Millimeters)									KSPH Torque (Nm)
						A	BE	B	C	D	E	F	J	GAP	
112	560	4,000	40	16	0.05	112	CUSTOM	2C + BE	50	58	79	54	40	8	960
125	1,050	4,000	50	31	0.06	125			63	70	92	67	43	8	1,650
140	1,510	4,000	56	31	0.09	140			71	80	107	75	47	8	2,490
160	2,310	4,000	65	31	0.12	160			80	95	120	85	52	10	3,900
180	3,550	4,000	75	45	0.15	180			90	105	134	95	56	10	5,940
200	5,060	3,810	85	45	0.20	200			100	120	149	105	61	10	8,290
224	7,350	3,410	100	51	0.31	224			112	145	174	118	65	12	14,140
250	9,920	3,050	115	51	0.45	250			125	165	200	131	74	12	20,450
280	17,170	2,720	135	51	0.59	280			140	190	224	147	82	14	29,170
315	27,070	2,420	160	112	0.94	315			170	225	260	178	98	16	38,270
355	39,880	2,150	180	125	1.11	355			190	250	288	198	108	16	56,450
400	56,000	1,900	200	140	1.70	400			200	285	329	209	114	18	88,890

\* Coupling Weight is without Bore Machining  
 \* Refer to KCP for size 450 ~ 1250