

G52 Type (Large)

Large Flanged Sleeve Single Engagement

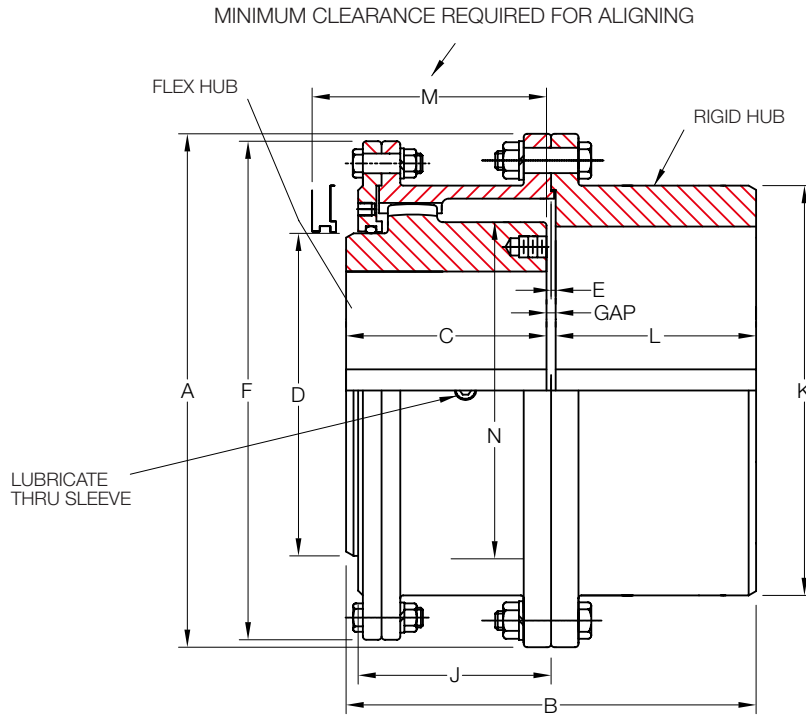

※ IMPORTANT : When couplings are mounted on a floating shaft, do not exceed allowable shaft speed for the assembly.

Size	Torque Rating (Nm)	Allow Speed RPM	Max Bore		Min Bore (mm)	Cplg Weight (Kg)	Lube Weight (Kg)	Dimensions (Millimeters)											
			Flex (mm)	Rigid (mm)				A	B	C	D	E	F	J	K	L	M	N	GAP
1080	170,000	1,750	266	340	101.60	699	5	590.6	511.0	249.4	355.6	8.1	571.5	242.8	450.8	248.9	300.0	368.3	13
1090	226,000	1,550	290	380	114.30	984	6	660.4	566.4	276.4	393.7	8.1	641.4	265.2	508.0	275.8	327.2	419.1	14
1100	310,000	1,450	320	400	127.00	1,252	8	711.2	625.3	304.8	444.5	9.7	698.5	293.6	530.4	304.8	355.6	469.9	16
1110	413,000	1,330	373	440	139.70	1,637	9	774.7	682.2	333.2	495.3	9.7	749.3	322.3	584.2	333.2	384.0	520.7	16
1120	555,000	1,200	400	483	152.40	2,077	11	838.2	720.6	352.6	546.1	9.7	825.5	341.4	647.7	352.3	403.4	571.5	16
1130	719,000	1,075	440	500	165.10	2,572	17	911.4	761.7	371.3	584.2	9.7	886.0	362.0	708.2	371.3	434.8	609.6	19
1140	911,000	920	460	535	177.80	3,062	17	965.2	805.9	393.2	635.0	9.7	939.8	378.0	749.3	393.7	457.2	660.4	19
1150	1,100,000	770	490	580	190.50	3,751	21	1,028.7	857.2	419.1	685.8	9.7	1,003.3	407.9	812.8	419.1	482.6	711.2	19
1160	1,310,000	650	525	630	254.00	4,631	22	1,111.2	908.3	441.3	736.6	12.7	1,085.8	419.1	886.0	441.5	501.6	762.0	25
1180	1,660,000	480	600	710	285.75	6,069	25	1,219.2	939.8	457.2	838.2	12.7	1,193.8	434.8	993.6	457.2	520.7	863.6	25
1200	2,140,000	370	660	780	371.50	8,482	34	1,358.9	1,098.6	536.6	927.1	12.7	1,308.1	514.4	1,095.2	536.4	635.0	965.2	25
1220	2,720,000	290	725	890	349.25	11,680	54	1,511.3	1,196.8	584.2	1,016.0	12.7	1,473.2	565.2	1,244.6	584.2	685.8	1,066.8	28

* Coupling Weight is without Bore Machining