

## G20 Type (Large)

### Large Flanged Sleeve Double Engagement

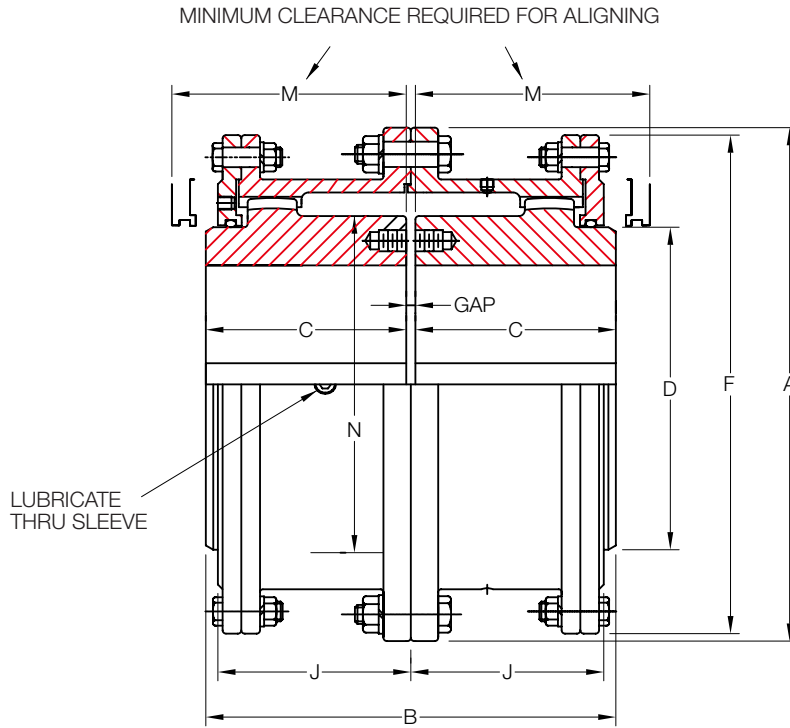

Size	Torque Rating (Nm)	Allow Speed RPM	Max Bore (mm)	Min Bore (mm)	Cplg Weight (Kg)	Lube Weight (Kg)	Dimensions (Millimeters)								
							A	B	C	D	F	J	M	N	GAP
1080	170,000	1,750	266	101.60	703	9.5	590.6	508.5	249.2	355.6	571.5	242.8	300.0	368.3	10
1090	226,000	1,550	290	114.30	984	12.2	660.4	565.4	276.4	393.7	641.4	265.2	327.2	419.1	13
1100	310,000	1,450	320	127.00	1,302	15.0	711.2	622.3	304.8	444.5	698.5	293.6	355.6	469.9	13
1110	413,000	1,330	373	139.70	1,678	17.7	774.7	679.2	333.2	495.3	479.3	322.3	384.0	520.7	13
1120	555,000	1,200	400	152.40	2,114	20.9	838.2	717.8	352.6	546.1	825.5	341.4	403.4	571.5	13
1130	719,000	1,075	440	165.10	2,595	32.7	911.4	761.7	371.3	584.2	886	362.0	434.8	609.6	19
1140	911,000	920	460.0	177.80	3,107	33.1	965.2	806.4	393.2	635.0	939.8	378.0	457.2	660.4	19
1150	1,100,000	770	490.0	190.50	3,765	40.8	1,028.7	857.2	419.1	685.8	1,003.3	407.9	482.6	711.2	19
1160	1,310,000	650	525	254.00	4,708	43.1	1,111.2	908.0	441.3	736.6	1,085.9	419.1	504.6	762	25
1180	1,660,000	480	600	285.75	6,260	49.9	1,219.2	939.8	457.2	838.2	1,193.8	434.8	520.7	863.6	25
1200	2,140,000	370	660	317.50	8,582	68.0	1,358.9	1,098.60	536.6	927.1	1,308.1	514.4	635.0	965.2	25
1220	2,720,000	290	725	349.25	11,685	107.0	1,511.3	1,193.80	584.2	1,016.0	1,473.2	565.2	685.8	1,066.8	25

\* Coupling Weight is without Bore Machining