

KFR Type

Close Coupled

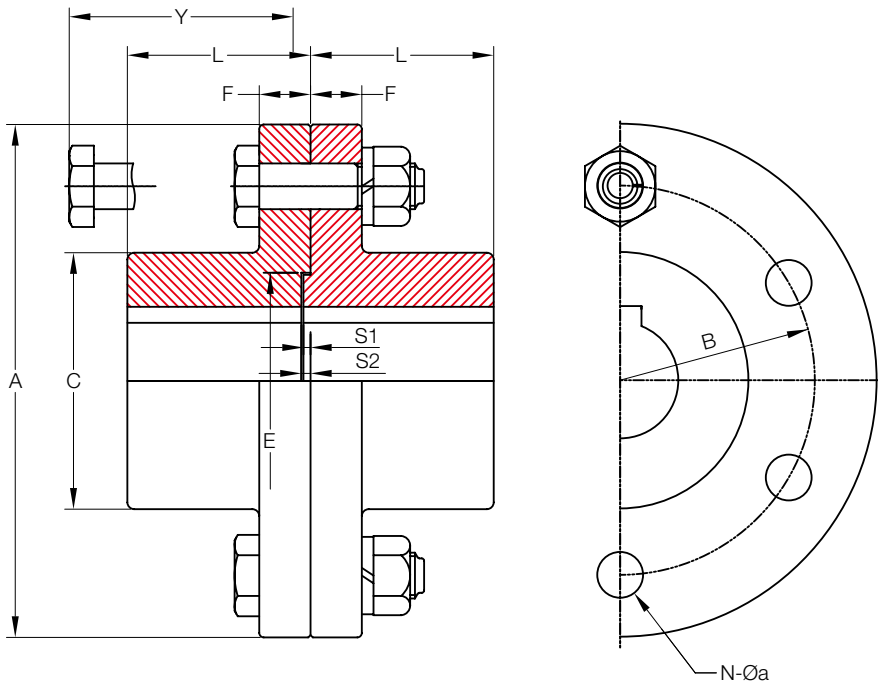

Size	Torque Rating (Nm)	Allow Speed RPM	Max Bore (mm)	Min Bore (mm)	Cplg Weight (Kg)	GD (Kg.m ²)	Dimensions (Millimeters)							Spigot and Socket		
							A	L	C	B	F1	Y	N-Øa	E	S1	S2
112	62	4,000	28	16	2.78	0.0163	112	40	50	75	16	70	4-Ø10	40	3	2
125	88	4,000	28	18	3.76	0.0276	125	45	56	85	18	81	4-Ø14	45	3	2
140	176	4,000	35	20	5.06	0.0449	140	50	71	100	18	81	6-Ø14	56	3	2
160	348	4,000	45	25	6.98	0.0788	160	56	80	115	18	81	8-Ø14	71	3	2
180	490	3,500	50	28	9.23	0.1290	180	63	90	132	18	81	8-Ø14	80	3	2
200	696	3,200	56	32	14.40	0.2550	200	71	100	145	22.4	103	8-Ø16	100	4	3
224	980	2,850	63	35	18.40	0.4050	224	80	112	170	22.4	103	8-Ø16	100	4	3
250	1,372	2,550	71	40	27.80	0.7630	250	90	125	180	28	126	8-Ø20	112	4	3
280	1,960	2,300	80	50	38.90	1.3700	280	100	140	200	28	126	8-Ø20	125	4	3
315	2,744	2,050	90	63	51.20	2.2300	315	112	160	236	28	126	8-Ø25	140	4	3
355	2,920	1,800	100	71	81.40	4.6700	355	125	180	260	35.5	157	10-Ø20	160	4	4

* Coupling Weight is without Bore Machining