

## bourdon tube pressure gauges NACE MR0103/MR0175 - ISO 15156-3 version DS 4", 6" (100-150mm)



PED 2014/68/UE ATEX 2014/34/UE

These instruments are designed for petrochemical industry. They are built to resist to the most severe conditions created by H<sub>2</sub>S, by the environment and for those fluids which are highly viscous and do not crystallize. The quality of the materials used to build the sensible element makes them suitable for working in high frequency pulsating pressures conditions. The TIG welding between the case and the process socket, strengthens the instrument and assures a better tight in case of dampening fluid. The advantages of filling the case of the instrument with a dampening fluid are: reduced pointer fluctuation, reduced wear of rotating parts of the movement when pulsant vibrations and pulsations occur. Moreover, condensate and corrosive atmospheres, which could damage the internal parts, are prevented.

### 1.36.1 - Standard Model

**Design:** EN 837-1, ISO 15156-3.

**Safety designation:** S1 as per EN 837-2.

**Ranges:** from 0...15 to 0...10000 psi (from 0...1 to 0...600 bar or equivalent units).

**Accuracy class:** 1 as per EN 837-1.

**Ambient temperature:**

-40...+149 °F (-40...+65 °C), IP55 housing (EN 60529/IEC 529);

-58...+149 °F (-50...+65 °C), vented IP67 housing

(EN 60529/IEC 529).

**Process fluid temperature:** -40...+302 °F (-40...+150 °C).

**Thermal drift:** ±0,4 %/10 °C of range (starting from 68°F - 20°C).

**Working pressure:**

100% of FSV for static pressure;

90% of FSV for pulsating pressure.

**Over pressure limit:** 30% of FSV (max 12 hours).

**Socket material:** AISI 316L st.st. or Monel 400.

**Bourdon tube:** Monel 400 seamless tube.

**Leak test:** Helium Test leak Search (max 1x10<sup>-6</sup> mbar x l x s<sup>-1</sup>)

**Case:** stainless steel.

**Ring:** stainless steel, bayonet lock.

**Window:** tempered glass (with external zero adjustment on request).

**Movement:** stainless steel with internal limit stops.

**Dial:** aluminium, white with black markings.

**Pointer:** adjustable, aluminium, black.

### 1.36.2 - Fillable Model

**Ambient temperature:** -40...+149 °F (-40...+65 °C), IP 67 housing (EN 60529/IEC 529).

**Other features:** as Standard Model.

### 1.36.3 - Filled Model

**Damping liquid:** glycerine 98% or silicon oil.

**Ambient temperature:**

+32...+149 °F (0...+65 °C) with glycerine filling;

-4...+149 °F (-20...+65 °C) with glycerine filling mixture;

-40...+149 °F (-40...+65 °C) with silicon oil fluid filling.

**Process fluid temperature:** max +149°F (+65 °C).

**Protection degree:** IP 67 as per EN 60529/IEC 529.

**Other features:** as Standard Model.

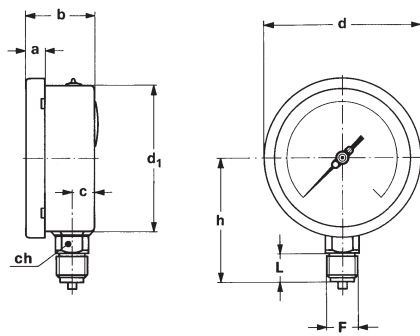

A - LOWER CONNECTION

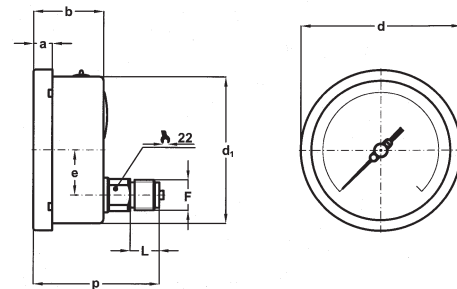

D - BACK CONNECTION

Mounting	DS	F	a	b	c	d	d <sub>1</sub>	e	h	p	L	Weight (1)
Lower	E 4" (100)	41M - G 1/2 A	0.51"	1.90"	0.59"	4.35"	3.97"		3.38"		0.78"	1.16 lbs
		43M - 1/2-14 NPT	(13)	(48,5)	(15)	(110,6)	(101)		(86)		(20)	(0,53 kg)
	F 6" (150)	41M - G 1/2 A	0.59"	1.96"	0.61"	6.33"	5.88"		4.60		0.78"	2.09 lbs
Back	E 4" (100)	41M - G 1/2 A	0.51"	1.90"		4.35"	3.97"	1.22"		3.42"	0.78"	1.17 lbs
		43M - 1/2-14 NPT	(13)	(48,5)		(110,6)	(101)	(31)		(87)	(20)	(0,53 kg)
	G 6" (150)	41M - G 1/2 A	0.59"	1.96"		6.33"	5.88"	1.22"		3.36"	0.78"	1.87 lbs
		43M - 1/2-14 NPT	(15)	(50,5)		(161)	(149,6)	(31)		(85,5)	(20)	(0,85 kg)

dimensions : inches (mm)

(1) add 0.72 lbs (0,33 kg) for DS 4" (100) and 1.65 lbs (0,78 kg) for DS 6" (150), when filled

OPTIONS

Model	standard	fillable	filled
B - "U"-clamp, for back connection pressure gauges	◆	◆	◆
C - Back flange, for lower connection pressure gauges	◆	◆	◆
E - Front flange, for back connection pressure gauges	◆	◆	◆
2G1 - ATEX II 2G c version	See the ATEX pressure gauges data-sheet for technical details		
2D1 - ATEX II 2GD c version			
C40 - AISI 316L st. st. case and ring	◆	◆	◆
E07 - Socket material MONEL 400	◆	◆	◆
E30 - NACE MR0103/MR0175 -ISO15156-3 certificate	◆	◆	◆
P01 - Suitable for filling with silicone		◆	
K06 - Accuracy class 0,6 (1)	◆	◆	
S10 - Silicone filling			◆
T01 - Tropicalization	◆	◆	◆
T32 - Safety glass window	◆	◆	◆

(1) to be ordered with E67 option

(3) to be ordered with ECV option

(2) not adjustable pointer

"HOW TO ORDER" SEQUENCE

Section / Model / Case / Mounting / Diameter / Special version / Range / Process connection / Options

1 36 1 A E --- 41M B...E  
2 D G E07 43M 2G1...T32  
3

