



NP400

RELATIVE PRESSURE TRANSMITTER – INSTRUCTIONS MANUAL – V1.0x C

INTRODUCTION

The NP400 positive relative pressure transmitters are robust and reliable equipment suitable for general industrial applications. They are available in several measuring ranges and process connection threads.

PRECAUTION

Before operating the transmitter, carefully read its specifications and operating instructions. In case of damage caused by incorrect operation or inappropriate usage, and its consequences, warranty becomes ineffective and null.

A specialized professional shall perform the installation.

A specific electrical power supply network should be provided for instruments use only.

UNPACKING

After unpacking the product, besides the transmitter it must be available:

- A quick guide to installation and operation.
- A sealed electrical connector.
- A screw to fix the connector to the transmitter.

IDENTIFICATION

An identification label is attached to the equipment housing. On this label, you can find detailed information about the transmitter.

Fig. 1 shows the identification label.

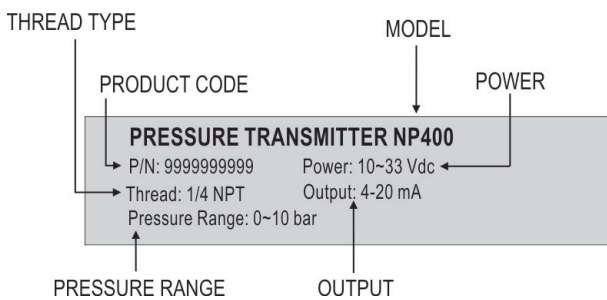

Fig. 1 – Transmitter identification

SPECIFICATIONS

Type of Measure:

Positive relative pressure

Pressure Range:

0-2 / 0-5 / 0-10 / 0-20 / 0-50 / 0-100 bar (*)

Measurement Accuracy:

< ±0.5 % pressure range
< ±1.0 % pressure range for 0~100 bar model
Including linearity, hysteresis and repeatability, in 25 °C

Thermal Deviation Maximum:

< ± 0.06 % the span / °C

Overpressure Range:

Twice the pressure range upper value.

Rupture Pressure:

Three times the pressure range upper value.

Output Signal (Output):

Electric current, 4-20 mA, 2 wires.

Power Supply (Power):

10 to 33 Vdc

Maximum Load (RL):

$RL = (Vdc - 10) / 0.02 (\Omega)$
Where: Vdc= Power supply voltage

Electrical Connection:

Connector for Type A valves (DIN EN 175301-803), IP65.
Conductor 1.5 mm² (max.) and cables between 6 and 8 mm in diameter.

Operating Temperature:

-20 to 70 °C

Medium Temperature:

-20 to 100 °C

Dynamic Response:

< 30 ms

Process Connection (Thread):

¼ NPT; ½ NPT; ½ BSP; G ¼ (*)

Sensor features:

Piezoresistive – Thick Film on Ceramics (Al₂O₃ 96 %)

Metal housing of the transmitter:

Stainless 316

Wetted parts:

Sensor Ceramic, Al₂O₃ 96 %
Sealing Ring, FKM
Metal Connection, stainless steel 316

Compatibility: Any gas or liquid compatible with the constituent materials of the wetted parts.

(*) Information available on the product identification label.

Note: For models with process connection ½ BSP and G ¼, the outer seals are manufactured with FKM.

ELECTRICAL CONNECTIONS

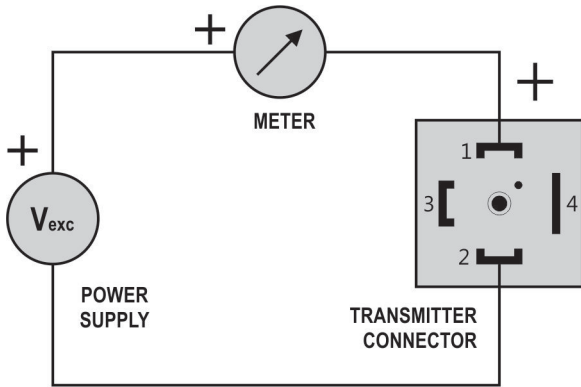

Fig. 2 – Electrical connections

Installation recommendations

- The instruments must be powered from a dedicated instrumentation power supply.
- It is strongly recommended to apply RC'S FILTERS (noise suppressor) to contactor coils, solenoids, etc.
- To improve measurement stability, immunity and safety, it is recommended to use system grounding.

DIMENSIONS

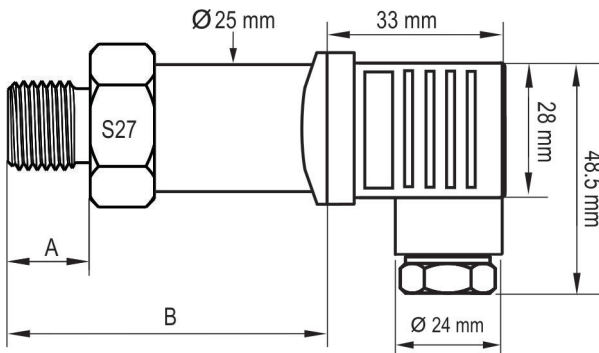

Fig. 3 – Transmitter dimensions

THREAD	A (mm)	B (mm)	WEIGHT (g)
NPT ¼	15.5	51.0	106
NPT ½	20.0	56.5	159
BSP ½	14.0	49.5	121
G ¼	14.0	49.5	105

Table 1 – Transmitter thread type, dimensions and weight

WARRANTY

Warranty conditions are on our website www.novusautomation.com/warranty.