

# Technical Information

## Cerabar PMC71B

Process pressure and level measurement in liquids or gases



Digital pressure transmitter with ceramic process membrane

### Applications

- Pressure measuring ranges: up to 40 bar (600 psi)
- Completely vacuum resistant: up to +150 °C (302 °F) process temperature
- Accuracy: up to  $\pm 0.025\%$

### Advantages

The new Cerabar generation introduces a robust pressure transmitter that combines numerous benefits: Easiest local or remote operation, allows condition-based maintenance and offers smart safety in processes. The firmware is designed to ensure extremely easy handling. Intuitive and clear wizard navigation guides the user through the commissioning and verification of the device. The Bluetooth connectivity provides safe and remote operation. The large display with backlight guarantees excellent readability. The Heartbeat Technology software package offers an on-demand verification and monitoring function to detect undesired anomalies, such as dynamic pressure shocks or changes in the supply voltage. The device features a ceramic membrane for abrasive, corrosive or vacuum applications with integrated membrane breakage diagnostic.

## Table of contents

<b>About this document</b> .....	<b>4</b>	Operating altitude .....	28
Symbols .....	4	Climate class .....	28
List of abbreviations .....	5	Degree of protection .....	28
Turn down calculation .....	5	Vibration resistance .....	29
		Electromagnetic compatibility (EMC) .....	29
<b>Function and system design</b> .....	<b>6</b>	<b>Process</b> .....	<b>30</b>
Measuring principle .....	6	Process temperature range .....	30
Measuring system .....	6	Thermal shock .....	31
Communication and data processing .....	7	Process pressure range .....	31
Dependability for devices with HART, Bluetooth, PROFINET with Ethernet-APL .....	7	Ultrapure gas applications .....	32
		Steam applications and saturated steam applications .....	32
<b>Input</b> .....	<b>9</b>	<b>Mechanical construction</b> .....	<b>33</b>
Measured variable .....	9	Design, dimensions .....	33
Measuring range .....	9	Dimensions .....	34
		Weight .....	44
<b>Output</b> .....	<b>11</b>	Materials in contact with process .....	45
Output signal .....	11	Materials not in contact with process .....	45
Signal on alarm .....	11	Accessories .....	46
Load .....	11		
Damping .....	11	<b>Operability</b> .....	<b>47</b>
Ex connection data .....	11	Operating concept .....	47
Linearization .....	11	Languages .....	47
Protocol-specific data .....	12	Local operation .....	48
Wireless HART data .....	13	Local display .....	48
		Remote operation .....	50
<b>Power supply</b> .....	<b>14</b>	System integration .....	51
Terminal assignment .....	14	Supported operating tools .....	51
Available device plugs .....	14	HistoROM .....	51
Supply voltage .....	16		
Electrical connection .....	16	<b>Certificates and approvals</b> .....	<b>52</b>
Potential equalization .....	17	CE mark .....	52
Terminals .....	17	RCM-Tick marking .....	52
Cable entries .....	17	Ex approvals .....	52
Cable specification .....	17	Sanitary compatibility .....	52
Overvoltage protection .....	17	EAC conformity .....	52
		Drinking water approval .....	52
<b>Performance characteristics</b> .....	<b>19</b>	Overfill protection (in preparation) .....	52
Response time .....	19	Functional safety SIL/ IEC 61508 Declaration of Conformity (optional) .....	52
Reference operating conditions .....	19	Marine approval .....	53
Total performance .....	19	Radio approval .....	53
Resolution .....	21	CRN approval .....	53
Total error .....	21	Test reports .....	53
Long-term stability .....	22	Pressure Equipment Directive 2014/68/EU (PED) .....	53
Response time T63 and T90 .....	22	Oxygen application .....	54
Installation factors .....	22	PWIS-free applications .....	54
Warm-up time (according to IEC62828-4) .....	23	China RoHS symbol .....	54
		RoHS .....	54
<b>Mounting</b> .....	<b>24</b>	Certification PROFINET with Ethernet-APL .....	54
Orientation .....	24	Additional certification .....	54
Installation instructions .....	24		
Sensor selection and arrangement .....	24	<b>Ordering information</b> .....	<b>55</b>
Special mounting instructions .....	25	Ordering information .....	55
		Scope of delivery .....	55
<b>Environment</b> .....	<b>28</b>	Measuring point (tag) .....	55
Ambient temperature range .....	28	Test reports, declarations and inspection certificates .....	55
Storage temperature .....	28		

<b>Application packages</b> .....	<b>56</b>
Heartbeat Technology .....	56
High-temperature version .....	56
<b>Accessories</b> .....	<b>57</b>
Device-specific accessories .....	57
Device Viewer .....	57
<b>Documentation</b> .....	<b>58</b>
Standard documentation .....	58
Supplementary device-dependent documentation .....	58
Field of Activities .....	58
Special Documentation .....	58
<b>Registered trademarks</b> .....	<b>58</b>

## About this document

### Symbols

#### Safety symbols

##### DANGER

This symbol alerts you to a dangerous situation. Failure to avoid this situation will result in serious or fatal injury.

##### WARNING

This symbol alerts you to a dangerous situation. Failure to avoid this situation can result in serious or fatal injury.

##### CAUTION

This symbol alerts you to a dangerous situation. Failure to avoid this situation can result in minor or medium injury.

##### NOTICE

This symbol contains information on procedures and other facts which do not result in personal injury.

#### Electrical symbols

Ground connection:  $\perp$

Terminal for connection to the grounding system.

#### Symbols for certain types of information

Permitted: 

Procedures, processes or actions that are permitted.

Forbidden: 

Procedures, processes or actions that are forbidden.

Additional information: 

Reference to documentation: 

Reference to page: 

Series of steps: **1.**, **2.**, **3.**

Result of an individual step: 



#### Symbols in graphics

Item numbers: 1, 2, 3 ...

Series of steps: **1.**, **2.**, **3.**

Views: A, B, C, ...

#### Symbols on the device

Safety instructions:  → 

Observe the safety instructions contained in the associated Operating Instructions.

List of abbreviations

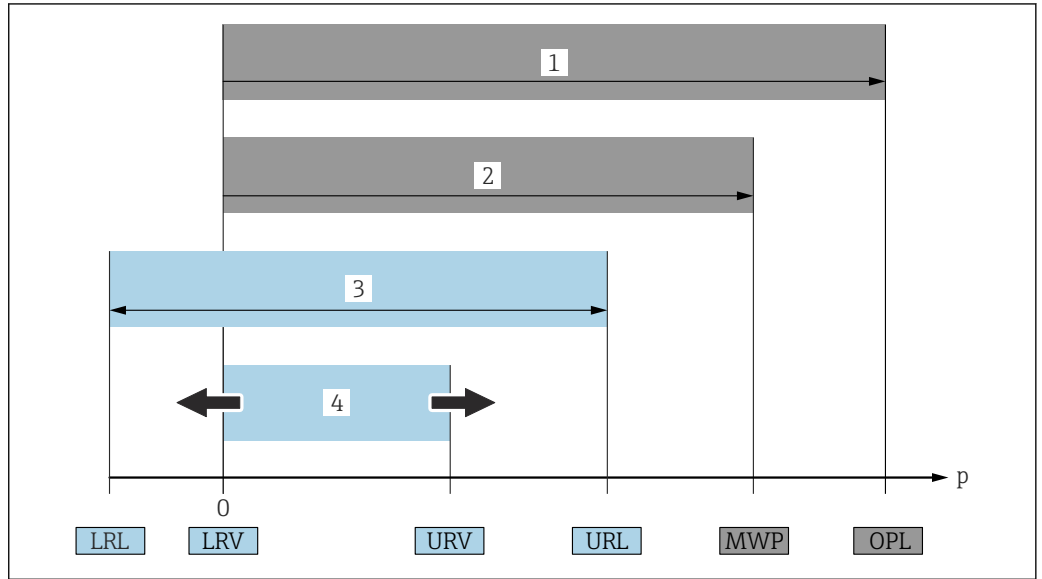

- 1 OPL: The OPL (overpressure limit = measuring cell overload limit) for the device depends on the lowest-rated element, with regard to pressure, of the selected components, i.e. the process connection has to be taken into consideration in addition to the measuring cell. Pay attention to the pressure/temperature dependency.
  - 2 The MWP (maximum working pressure) for the measuring cells depends on the lowest-rated element, with regard to pressure, of the selected components, i.e. the process connection has to be taken into consideration in addition to the measuring cell. Pay attention to the pressure/temperature dependency. The MWP may be applied at the device for an unlimited period of time. The MWP can be found on the nameplate.
  - 3 The maximum measuring range corresponds to the span between the LRL and URL. This measuring range is equivalent to the maximum calibratable/adjustable span.
  - 4 The calibrated/adjusted span corresponds to the span between the LRV and URV. Factory setting: 0 to URL. Other calibrated spans can be ordered as customized spans.
- p Pressure  
 LRL Lower range limit  
 URL Upper range limit  
 LRV Lower range value  
 URV Upper range value  
 TD Turn down. Example - see the following section.

Turn down calculation

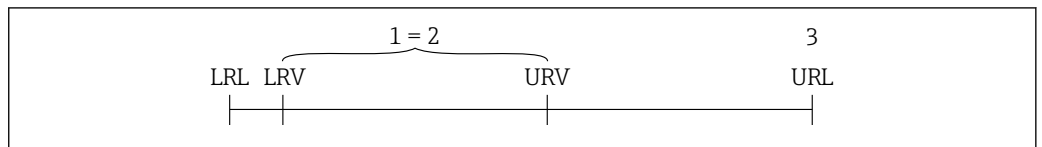

- 1 Calibrated/adjusted span
- 2 Zero point-based span
- 3 Upper range limit

Example:

- Measuring cell: 10 bar (150 psi)
- Upper range limit (URL) = 10 bar (150 psi)
- Calibrated/adjusted span: 0 to 5 bar (0 to 75 psi)
- Lower range value (LRV) = 0 bar (0 psi)
- Upper range value (URV) = 5 bar (75 psi)

$$TD = \frac{URL}{|URV - LRV|}$$

In this example, the TD is 2:1. This span is based on the zero point.

## Function and system design

### Measuring principle

#### Ceramic membrane (Ceraphire®)

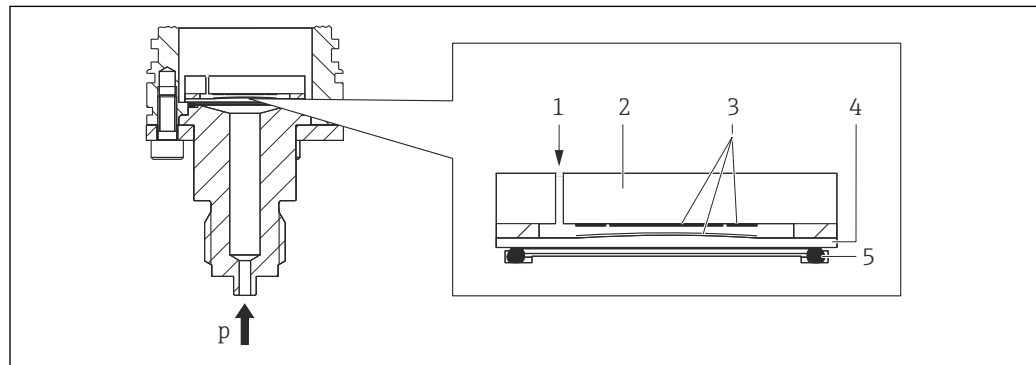

A0043088

- 1 Atmospheric pressure (gauge pressure measuring cells)
- 2 Ceramic meter body
- 3 Electrodes
- 4 Ceramic membrane
- 5 Seal
- $p$  Pressure

The ceramic measuring cell is an oil-free measuring cell. The pressure acts directly on the robust ceramic membrane, causing it to deflect. A pressure-dependent change in capacitance is measured at the electrodes of the ceramic meter body and the membrane. The measuring range is determined by the thickness of the ceramic membrane.

#### Advantages:

- High overload resistance
- Thanks to ultrapure 99.9 % ceramic
  - Extremely high chemical durability
  - Resistant to abrasion and corrosion
  - High mechanical durability
- Suitable for vacuum applications
- Secondary containment for enhanced integrity

### Measuring system

#### Level measurement (level, volume and mass):

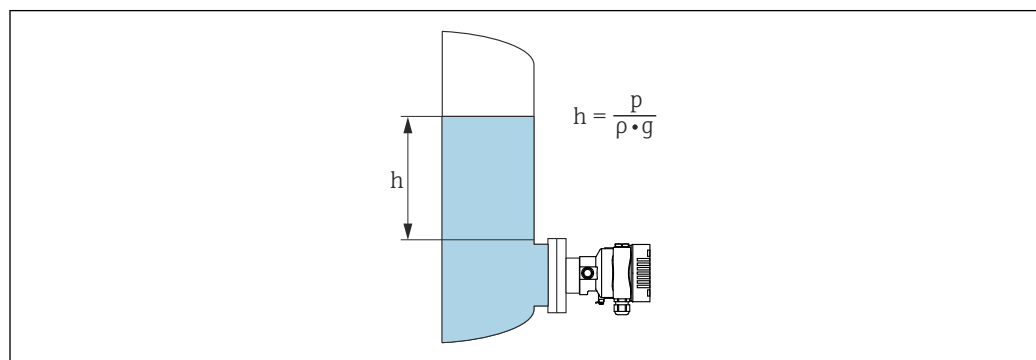

A0038343

- $h$  Height (level)
- $p$  Pressure
- $\rho$  Density of the medium
- $g$  Gravitational acceleration

*Advantages:*

- Volume and mass measurements in any vessel shape with a freely programmable characteristic curve
- Has a wide range of uses, e.g.
  - For foam formation
  - In vessels with agitators or screen fittings
  - For liquid gases

**Communication and data processing**

- 4 to 20 mA with HART communication protocol
- Bluetooth (optional)
- PROFINET with Ethernet-APL: 10BASE-T1L communication protocol

**Dependability for devices with HART, Bluetooth, PROFINET with Ethernet-APL**

**IT security**

Endress+Hauser can only provide a warranty if the device is installed and used as described in the Operating Instructions. The device is equipped with security mechanisms to protect it against any inadvertent changes to the device settings. IT security measures in line with operators' security standards and designed to provide additional protection for the device and device data transfer must be implemented by the operators themselves.

**Device-specific IT security**

The device offers specific functions to support protective measures by the operator. These functions can be configured by the user and guarantee greater in-operation safety if used correctly. An overview of the most important functions is provided in the following section:

- Write protection via hardware write protection switch
- Access code to change the user role (applies for operation via display, Bluetooth, or FieldCare, DeviceCare, Asset Management Tools (e.g. AMS, PDM and web server)

Function/interface	Factory setting	Recommendation
Access code (also applies for web server login or FieldCare connection)	Not enabled (0000)	Assign a customized access code during commissioning.
Web server	Enabled	On an individual basis following risk assessment.
Service interface (CDI)	Enabled	On an individual basis following risk assessment.
Write protection via hardware write protection switch	Not enabled	On an individual basis following risk assessment.

*Protecting access via a password*

Different passwords are available to protect write access to the parameters of the device.

Protect write access to the parameters of the device via the local display, web browser or operating tool (e.g. FieldCare, DeviceCare). Access authorization is clearly regulated through the use of a user-specific access code.

*User-specific access code*

Write access to the parameters of the device via the local display, web browser or operating tool (e.g. FieldCare, DeviceCare) can be protected using the editable, user-specific access code.

*General notes on the use of passwords*

- During commissioning, change the access code that was used when the device was delivered from the factory
- When defining and managing the access code, comply with the general rules for the generation of a secure password
- The user is responsible for managing the access code and for using the code with due care

*Access via web server*

Due to the integrated web server, the device can be operated and configured via a web browser and PROFINET with Ethernet-APL. In addition to the measured values, device status information is also

displayed, allowing users to monitor the status of the device. Furthermore the device data can be managed and the network parameters can be configured.

Access to the network is required for the PROFINET with Ethernet-APL connection.

#### *Supported functions*

Data exchange between the operating unit (such as a notebook for example) and the measuring device:

- Export parameter settings (PDF file, create documentation of the measuring point configuration)
- Export the Heartbeat Technology verification report (PDF file, only available with the "Heartbeat Verification" application package)
- Download driver (GSDML) for system integration

The web server is enabled when the device is delivered. The web server can be disabled via the **Web server functionality** parameter if necessary (e.g. after commissioning).

The device and status information can be hidden on the login page. This prevents unauthorized access to the information.



Detailed information on the device parameters:  
"Description of device parameters" document



## Input

### Measured variable

### Measured process variables

- Absolute pressure
- Gauge pressure

### Measuring range

Depending on the device configuration, the maximum working pressure (MWP) and the overpressure limit (OPL) can deviate from the values in the tables.

#### Absolute pressure

Measuring cell	Maximum measuring range		Smallest calibratable span (preset at factory) <sup>1) 2)</sup>
	lower (LRL)	upper (URL)	
	[bar <sub>abs</sub> (psi <sub>abs</sub> )]	[bar <sub>abs</sub> (psi <sub>abs</sub> )]	[bar (psi)]
100 mbar (1.5 psi)	0	+0.1 (+1.5)	0.005 (0.075) <sup>3)</sup>
250 mbar (3.75 psi)	0	+0.25 (+3.75)	0.005 (0.075) <sup>4)</sup>
400 mbar (6 psi)	0	+0.4 (+6)	0.005 (0.075) <sup>5)</sup>
1 bar (15 psi)	0	+1 (+15)	0.01 (0.15) <sup>6)</sup>
2 bar (30 psi)	0	+2 (+30)	0.02 (0.3) <sup>6)</sup>
4 bar (60 psi)	0	+4 (+60)	0.04 (0.6) <sup>6)</sup>
10 bar (150 psi)	0	+10 (+150)	0.1 (1.5) <sup>6)</sup>
40 bar (600 psi)	0	+40 (+600)	0.4 (6) <sup>6)</sup>

- 1) Turn down > 100:1 on request or can be set on device
- 2) The maximum TD is 5:1 in the case of platinum.
- 3) Largest factory-configurable turn down: 20:1
- 4) Largest factory-configurable turn down: 50:1
- 5) Largest factory-configurable turn down: 80:1
- 6) Largest factory-configurable turn down: 100:1

#### Absolute pressure

Measuring cell	MWP	OPL	Vacuum resistance
	[bar <sub>abs</sub> (psi <sub>abs</sub> )]	[bar <sub>abs</sub> (psi <sub>abs</sub> )]	[bar <sub>abs</sub> (psi <sub>abs</sub> )]
100 mbar (1.5 psi)	2.7 (40.5)	4 (60)	0
250 mbar (3.75 psi)	3.3 (49.5)	5 (75)	0
400 mbar (6 psi)	5.3 (79.5)	8 (120)	0
1 bar (15 psi)	6.7 (100.5)	10 (150)	0
2 bar (30 psi)	12 (180)	18 (270)	0
4 bar (60 psi)	16.7 (250.5)	25 (375)	0
10 bar (150 psi)	26.7 (400.5)	40 (600)	0
40 bar (600 psi)	40 (600)	60 (900)	0

#### Gauge pressure

Measuring cell	Maximum measuring range		Smallest calibratable span (preset at factory) <sup>1) 2)</sup>
	lower (LRL)	upper (URL)	
	[bar (psi)]	[bar (psi)]	[bar (psi)]
100 mbar (1.5 psi)	-0.1 (-1.5)	+0.1 (+1.5)	0.005 (0.075) <sup>3)</sup>
250 mbar (3.75 psi)	-0.25 (-3.75)	+0.25 (+3.75)	0.005 (0.075) <sup>4)</sup>
400 mbar (6 psi)	-0.4 (-6)	+0.4 (+6)	0.005 (0.075) <sup>5)</sup>

Measuring cell	Maximum measuring range		Smallest calibratable span (preset at factory) <sup>1) 2)</sup>
	lower (LRL)	upper (URL)	
	[bar (psi)]	[bar (psi)]	[bar (psi)]
1 bar (15 psi)	-1 (-15)	+1 (+15)	0.01 (0.15) <sup>6)</sup>
2 bar (30 psi)	-1 (-15)	+2 (+30)	0.02 (0.3) <sup>6)</sup>
4 bar (60 psi)	-1 (-15)	+4 (+60)	0.04 (0.6) <sup>6)</sup>
10 bar (150 psi)	-1 (-15)	+10 (+150)	0.1 (1.5) <sup>6)</sup>
40 bar (600 psi)	-1 (-15)	+40 (+600)	0.4 (6) <sup>6)</sup>

1) Turn down > 100:1 on request or can be set on device

2) The maximum TD is 5:1 in the case of platinum.

3) Largest factory-configurable turn down: 20:1

4) Largest factory-configurable turn down: 50:1

5) Largest factory-configurable turn down: 80:1

6) Largest factory-configurable turn down: 100:1

### Gauge pressure

Measuring cell	MWP	OPL	Vacuum resistance
	[bar (psi)]	[bar (psi)]	[bar <sub>abs</sub> (psi <sub>abs</sub> )]
100 mbar (1.5 psi)	2.7 (40.5)	4 (60)	0.7 (10.5)
250 mbar (3.75 psi)	3.3 (49.5)	5 (75)	0.5 (7.5)
400 mbar (6 psi)	5.3 (79.5)	8 (120)	0
1 bar (15 psi)	6.7 (100.5)	10 (150)	0
2 bar (30 psi)	12 (180)	18 (270)	0
4 bar (60 psi)	16.7 (250.5)	25 (375)	0
10 bar (150 psi)	26.7 (400.5)	40 (600)	0
40 bar (600 psi)	40 (600)	60 (900)	0

## Output

### Output signal

#### Current output

4 to 20 mA with superimposed digital communication protocol HART, 2-wire

The current output offers a choice of three different operating modes:

- 4.0 to 20.5 mA
- NAMUR NE 43: 3.8 to 20.5 mA (factory setting)
- US mode: 3.9 to 20.8 mA

#### PROFINET with Ethernet-APL

10BASE-T1L, 2-wire 10 Mbit

### Signal on alarm

Signal on alarm in accordance with NAMUR recommendation NE 43.

- 4 to 20 mA HART:
  - Options:
    - Max alarm: can be set from 21.5 to 23 mA
    - Min. alarm: < 3.6 mA (factory setting)
- PROFINET with Ethernet-APL:
  - According to "Application Layer protocol for decentralized periphery", Version 2.4
  - Device diagnostics according to PROFINET PA Profile 4.02

### Load

#### 4 to 20 mA HART

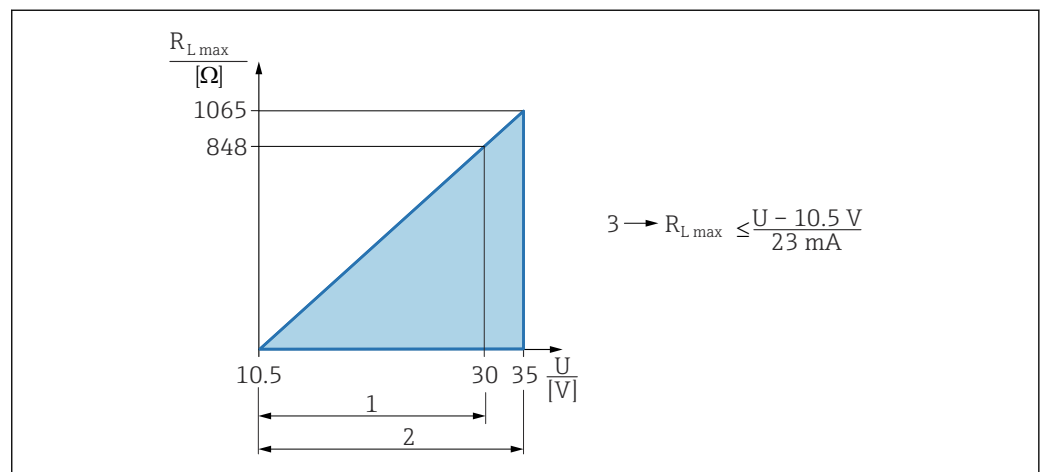

1 Power supply 10.5 to 30 VDC Ex i

2 Power supply 10.5 to 35 VDC, for other types of protection and non-certified device versions

3  $R_{Lmax}$  maximum load resistance

U Supply voltage



Operation via handheld terminal or PC with operating program: take minimum communication resistance of 250  $\Omega$  into consideration.

### Damping

A damping affects all outputs (output signal, display). Damping can be enabled as follows:

- Via the onsite display, Bluetooth, handheld terminal or PC with operating program, continuous from 0 to 999 seconds
- Factory setting: 1 s

### Ex connection data

See the separate technical documentation (Safety Instructions (XA)) on [www.endress.com/download](http://www.endress.com/download).

### Linearization

The device's linearization function allows the user to convert the measured value to any units of height or volume. User-defined linearization tables of up to 32 value pairs can be entered if necessary.

## Protocol-specific data

**HART**

- Manufacturer ID: 17 (0x11{hex})
- Device type ID: 0x112A
- Device revision: 1
- HART specification: 7
- DD revision: 1
- Device description files (DTM, DD) information and files at:
  - [www.endress.com](http://www.endress.com)
  - [www.fieldcommgroup.org](http://www.fieldcommgroup.org)
- HART load: min. 250 Ohm

*HART device variables (preset at the factory)*

The following measured values are assigned to the device variables at the factory:

Device variable	Measured value
Primary variable (PV) <sup>1)</sup>	Pressure <sup>2)</sup>
Secondary variable (SV)	Sensor temperature
Tertiary variable (TV)	Electronic temperature
Quaternary variable (QV)	Sensor pressure <sup>3)</sup>

- 1) The PV is always applied to the current output.
- 2) The pressure is the calculated signal after damping and position adjustment.
- 3) The Sensor pressure is the raw signal of the measuring cell before damping and position adjustment.

*Choice of HART device variables*

- **Pressure** option (after position adjustment and damping)
  - Scaled variable
  - Sensor temperature
  - Sensor pressure
    - Sensor Pressure is the raw signal from sensor before damping and position adjustment.
  - Electronics temperature
  - Terminal current
    - The terminal current is the read-back current on terminal block.
  - Terminal voltage 1
    - Visibility depends on order options or device settings
  - **Noise of pressure signal** option and **Median of pressure signal** option
    - Visible if Heartbeat Technology ordered
  - Percent of range
  - Loop current
    - The loop current is the output current set by the applied pressure.

*Supported functions*

- Burst mode
- Additional transmitter status
- Device locking

**PROFINET with Ethernet-APL**

<b>Protocol</b>	Application layer protocol for decentral device periphery and distributed automation, Version 2.4
<b>Communication type</b>	Ethernet Advanced Physical Layer 10BASE-T1L
<b>Conformance Class</b>	Conformance Class B
<b>Netload Class</b>	Netload Class II
<b>Baud rates</b>	Automatic 10 Mbit/s with full-duplex detection
<b>Cycle times</b>	From 32 ms
<b>Polarity</b>	Auto-polarity for automatic correction of crossed TxD and RxD pairs

<b>Media Redundancy Protocol (MRP)</b>	Yes
<b>System redundancy support</b>	System redundancy S2 (2 AR with 1 NAP)
<b>Device profile</b>	Application interface identifier 0xB310 Generic device
<b>Manufacturer ID</b>	0x11
<b>Device type ID</b>	A22A
<b>Device description files (GSD, FDI, DTM, DD)</b>	Information and files at: <ul style="list-style-type: none"> <li>▪ <a href="http://www.endress.com">www.endress.com</a> On the product page for the device: Documents/Software → Device drivers</li> <li>▪ <a href="http://www.profibus.org">www.profibus.org</a></li> </ul>
<b>Supported connections</b>	<ul style="list-style-type: none"> <li>▪ 2 x AR (IO Controller AR)</li> <li>▪ 1 x AR (IO-Supervisor Device AR connection allowed)</li> <li>▪ 1 x Input CR (Communication Relation)</li> <li>▪ 1 x Output CR (Communication Relation)</li> <li>▪ 1 x Alarm CR (Communication Relation)</li> </ul>
<b>Configuration options for device</b>	<ul style="list-style-type: none"> <li>▪ Manufacturer-specific software (FieldCare, DeviceCare)</li> <li>▪ Web browser</li> <li>▪ Device master file (GSD), can be read out via the integrated Web server of the device</li> <li>▪ DIP switch for setting the service IP address</li> </ul>
<b>Configuration of the device name</b>	<ul style="list-style-type: none"> <li>▪ DCP protocol</li> <li>▪ Process Device Manager (PDM)</li> <li>▪ Integrated Web server</li> </ul>
<b>Supported functions</b>	<ul style="list-style-type: none"> <li>▪ Identification &amp; Maintenance Simple device identification via: <ul style="list-style-type: none"> <li>▪ Control system</li> <li>▪ Nameplate</li> </ul> </li> <li>▪ Measured value status The process variables are communicated with a measured value status</li> <li>▪ Blinking feature via the local display for simple device identification and assignment</li> <li>▪ Device operation via operating tools (e.g. FieldCare, DeviceCare, SIMATIC PDM)</li> </ul>
<b>System integration</b>	For information on system integration, see the Operating Instructions <ul style="list-style-type: none"> <li>▪ Cyclic data transmission</li> <li>▪ Overview and description of the modules</li> <li>▪ Status coding</li> <li>▪ Startup configuration</li> <li>▪ Factory setting</li> </ul>

**Wireless HART data**

- Minimum starting voltage: 10.5 V
- Start-up current: 3.6 mA
- Start-up time: <5 s
- Minimum operating voltage: 10.5 V
- Multidrop current: 4 mA

## Power supply

### Terminal assignment

### Single compartment housing

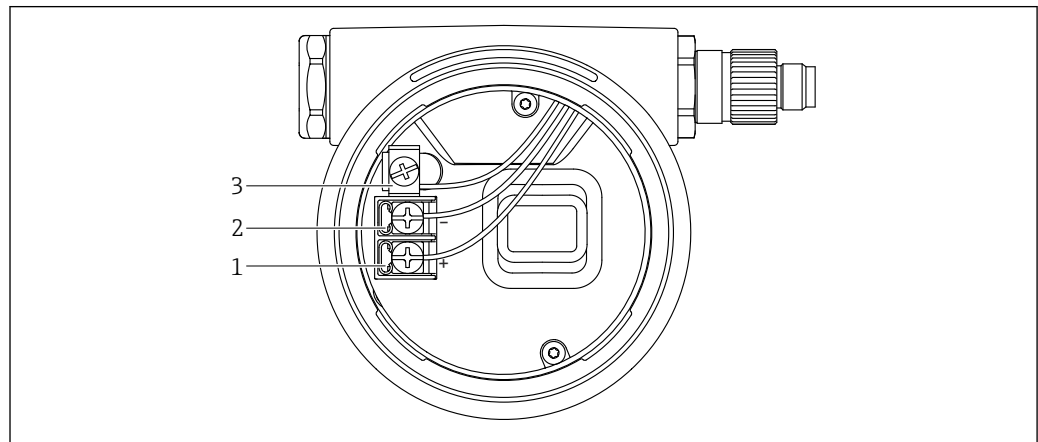

A0042594

1 Connection terminals and ground terminal in the connection compartment

- 1 Positive terminal
- 2 Negative terminal
- 3 Internal ground terminal

### Dual compartment housing

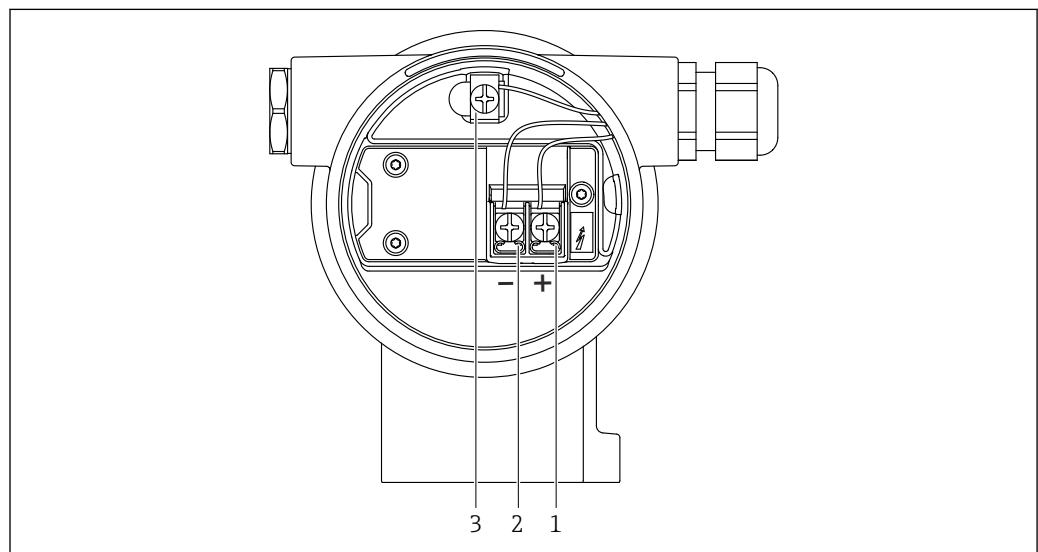

A0042803

2 Connection terminals and ground terminal in the connection compartment

- 1 Positive terminal
- 2 Negative terminal
- 3 Internal ground terminal

### Available device plugs

In the case of devices with a plug, it is not necessary to open the housing for connection purposes.

Use the enclosed seals to prevent the penetration of moisture into the device.

**Devices with M12 plug**

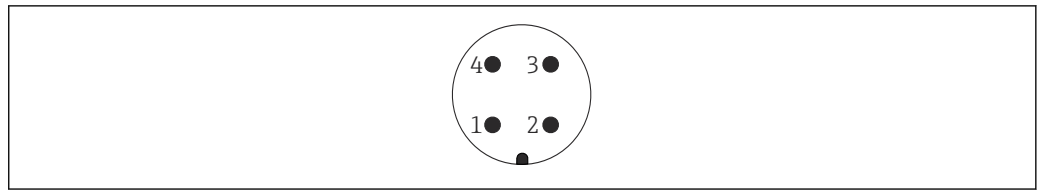

A0011175

3 View of the plug-in connection on the device

Pin	HART
1	Signal +
2	Not assigned
3	Signal -
4	Ground

Pin	PROFINET with Ethernet-APL
1	APL signal -
2	APL signal +
3	Shielding
4	Not assigned

Endress+Hauser offers the following accessories for devices with an M12 plug:

Plug-in jack M 12x1, straight

- Material:  
Body: PBT; union nut: nickel-plated die-cast zinc; seal: NBR
- Degree of protection (fully locked): IP67
- Order number: 52006263

Plug-in jack M 12x1, elbowed (not for PROFINET with Ethernet-APL)

- Material:  
Body: PBT; union nut: nickel-plated die-cast zinc; seal: NBR
- Degree of protection (fully locked): IP67
- Order number: 71114212

Cable 4x0.34 mm<sup>2</sup> (20 AWG) with M12 plug-in jack, elbowed, screw plug, length 5 m (16 ft)

- Material: body: TPU; union nut: nickel-plated die-cast zinc; cable: PVC
- Degree of protection (fully locked): IP67/68
- Order number: 52010285
- Cable colors
  - 1 = BN = brown
  - 2 = WT = white
  - 3 = BU = blue
  - 4 = BK = black

Devices with a Harting plug Han7D

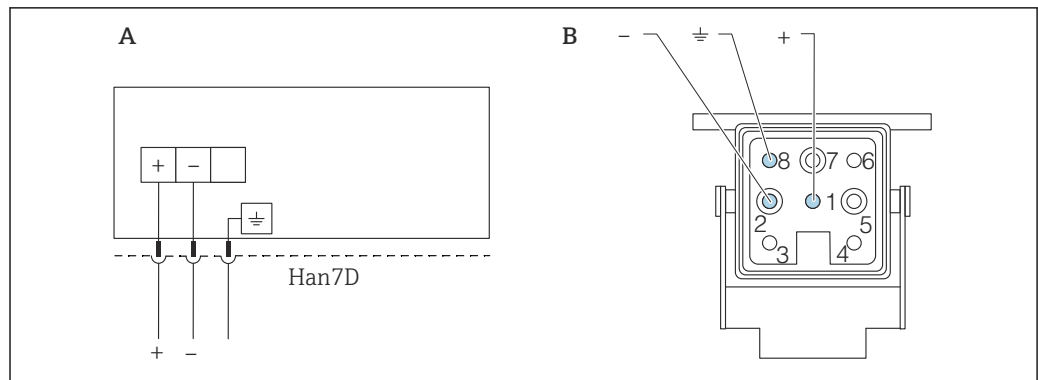

A Electrical connection for devices with Harting plug Han7D  
 B View of the plug-in connection on the device  
 - Brown  
 ⊕ Green/yellow  
 + Blue

A0041011

Material: CuZn, gold-plated contacts of the plug-in jack and plug

Supply voltage

- Analog/HART: Ex d, Ex e, non-Ex: supply voltage: 10.5 to 35 V<sub>DC</sub>
  - Analog/HART: Ex i: supply voltage: 10.5 to 30 V<sub>DC</sub>
  - HART: Nominal current: 4 to 20 mA HART
  - PROFINET with Ethernet-APL: APL power class A (9.6 to 15 V<sub>DC</sub> 540 mW)
- i** Analog/HART: The power unit must be tested to ensure it meets safety requirements (e.g., PELV, SELV, Class 2) and must comply with the relevant protocol specifications. The requirements for 4 to 20 mA are the same as those for HART.
- i** PROFINET with Ethernet-APL: The APL field switch must be tested to ensure it meets safety requirements (e.g., PELV, SELV, Class 2) and must comply with the relevant protocol specifications.

A suitable circuit breaker should be provided for the device in accordance with IEC/EN 61010.

Electrical connection

Connection examples

PROFINET with Ethernet-APL

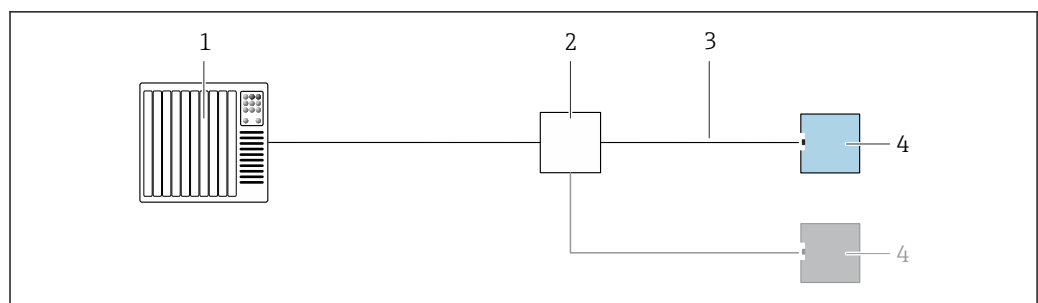

A0045802

**i** 4 Connection example for PROFINET with Ethernet-APL  
 1 Automation system  
 2 APL field switch  
 3 Observe cable specifications  
 4 Transmitter



**Potential equalization**

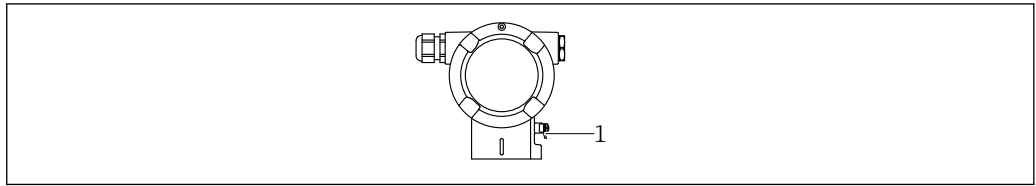

A0045412

1 Ground terminal for connecting the potential matching line

- i** If necessary, the potential matching line can be connected to the outer ground terminal of the device before the device is connected.
- i** For optimum electromagnetic compatibility:
  - Keep the potential matching line as short as possible
  - Maintain a cross-section of at least 2.5 mm<sup>2</sup> (14 AWG)

**Terminals**

- Supply voltage and internal ground terminal: 0.5 to 2.5 mm<sup>2</sup> (20 to 14 AWG)
- External ground terminal: 0.5 to 4 mm<sup>2</sup> (20 to 12 AWG)

**Cable entries**

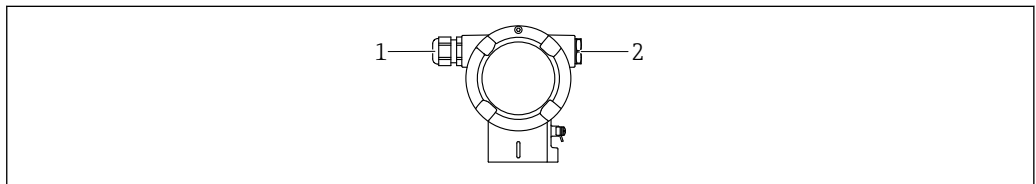

A0045414

1 Cable entry  
2 Dummy plug

The type of cable entry depends on the device version ordered.

- i** Always route connecting cables downwards so that moisture cannot penetrate the connection compartment.  
If necessary, create a drip loop or use a weather protection cover.

**Cable specification**

- The cable outer diameter depends on the cable entry used
- Cable outer diameter
  - Plastic: Ø5 to 10 mm (0.2 to 0.38 in)
  - Nickel-plated brass: Ø7 to 10.5 mm (0.28 to 0.41 in)
  - Stainless steel: Ø7 to 12 mm (0.28 to 0.47 in)

**PROFINET with Ethernet-APL**

The reference cable type for APL segments is fieldbus cable type A, MAU type 1 and 3 (specified in IEC 61158-2). This cable meets the requirements for intrinsically safe applications according to IEC TS 60079-47 and can also be used in non-intrinsically safe applications.

Cable type	A
Cable capacitance	45 to 200 nF/km
Loop resistance	15 to 150 Ω/km
Cable inductance	0.4 to 1 mH/km

Further details are provided in the Ethernet-APL Engineering Guideline (<https://www.ethernet-apl.org>).

**Overvoltage protection**

**Devices without optional overvoltage protection**

Equipment from Endress+Hauser fulfills the requirements of the product standard IEC / DIN EN 61326-1 (Table 2 Industrial Environment).

Depending on the type of port (DC power supply, input/output port) different testing levels according to IEC / DIN EN 61326-1 against transient overvoltages (Surge) are applied (IEC / DIN EN 61000-4-5 Surge):

Test level on DC power ports and input / output ports is 1000 V line to earth

**Devices with optional overvoltage protection**

- Spark-over voltage: min. 400 V DC
- Tested according to IEC / DIN EN 60079-14 sub chapter 12.3 (IEC / DIN EN 60060-1 chapter 7)
- Nominal discharge current: 10 kA

**Overvoltage category**

Overvoltage category II

## Performance characteristics

<b>Response time</b>	<ul style="list-style-type: none"> <li>■ HART: acyclic: min. 330 ms, typically 590 ms (depends on commands and number of preambles)</li> <li>■ HART: cyclic (burst): min. 160 ms, typically 350 ms (depends on commands and number of preambles)</li> <li>■ PROFINET with Ethernet-APL: cyclic: min. 32 ms</li> </ul>
<b>Reference operating conditions</b>	<ul style="list-style-type: none"> <li>■ As per IEC 62828-2</li> <li>■ Ambient temperature <math>T_A</math> = constant, in the range of +22 to +28 °C (+72 to +82 °F)</li> <li>■ Humidity <math>\varphi</math> = constant, in the range of: 5 to 80 % rF <math>\pm</math> 5 %</li> <li>■ Ambient pressure <math>p_A</math> = constant, in the range of: 860 to 1 060 mbar (12.47 to 15.37 psi)</li> <li>■ Position of the measuring cell: horizontal <math>\pm</math>1°</li> <li>■ Input of LOW SENSOR TRIM and HIGH SENSOR TRIM for lower range value and upper range value</li> <li>■ Supply voltage: 24 V DC <math>\pm</math>3 V DC</li> <li>■ Load with HART: 250 <math>\Omega</math></li> <li>■ Turn down (TD) = URL/   URV - LRV  </li> <li>■ Zero based span</li> </ul>
<b>Total performance</b>	<p>The performance characteristics refer to the accuracy of the device. The factors that influence the accuracy can be divided into two groups</p> <ul style="list-style-type: none"> <li>■ Total performance of device</li> <li>■ Installation factors</li> </ul> <p>All of the performance characteristics meet the requirement of <math>\geq \pm 3</math> sigma.</p> <p>The total performance of the device comprises the reference accuracy and the ambient temperature effect and is calculated using the following formula:</p> $\text{Total performance} = \pm \sqrt{(E1)^2 + (E2)^2}$ <p>E1 = Reference accuracy E2 = Temperature effect</p> <p>Calculation of E2:</p> <p>Temperature effect per <math>\pm 28</math> °C (50 °F) (Corresponds to a range of -3 to +53 °C (+27 to +127 °F))</p> $E2 = E2_M + E2_E$ <p><math>E2_M</math> = Main temperature error <math>E2_E</math> = Electronics error</p> <p>The values refer to the calibrated span.</p>

### Calculation of the total performance with the Endress+Hauser Applicator

Detailed inaccuracies, e.g. for other temperature ranges or the high-temperature version of the device can be calculated with the Applicator "[Sizing Pressure Performance](#)".



A0038927

### Reference accuracy [E1]

The reference accuracy comprises the non-linearity according to the limit point method, pressure hysteresis and non-repeatability in accordance with [IEC62828-1 / IEC 61298-2]. Reference accuracy for standard up to TD 100:1, for platinum up to TD 5:1.

#### Gauge pressure measuring cells

Measuring cell	Standard	Platinum
100 mbar (1.5 psi)	TD 1:1 to 10:1 = $\pm 0.075\%$ TD > 10:1 = $\pm 0.0075\% \cdot TD$	TD 1:1 = $\pm 0.05\%$ TD > 1:1 to TD 5:1 = $\pm 0.075\%$
250 mbar (3.75 psi)	TD 1:1 to 10:1 = $\pm 0.075\%$ TD > 10:1 = $\pm 0.0075\% \cdot TD$	TD 1:1 to TD 5:1 = $\pm 0.05\%$
400 mbar (6 psi) 1 bar (15 psi)	TD 1:1 to 10:1 = $\pm 0.05\%$ TD > 10:1 = $\pm 0.005\% \cdot TD$	TD 1:1 to TD 5:1 = $\pm 0.035\%$
2 bar (30 psi)	TD 1:1 to 10:1 = $\pm 0.05\%$ TD > 10:1 = $\pm 0.005\% \cdot TD$	TD 1:1 = $\pm 0.025\%$ TD > 1:1 to TD 5:1 = $\pm 0.035\%$
4 bar (60 psi)	TD 1:1 to 10:1 = $\pm 0.05\%$ TD > 10:1 = $\pm 0.005\% \cdot TD$	TD 1:1 to TD 5:1 = $\pm 0.025\%$
10 bar (150 psi) 40 bar (600 psi)	TD 1:1 to 10:1 = $\pm 0.05\%$ TD > 10:1 = $\pm 0.005\% \cdot TD$	TD 1:1 to TD 5:1 = $\pm 0.035\%$

#### Absolute pressure measuring cells

Measuring cell	Standard	Platinum
100 mbar (1.5 psi)	TD 1:1 to 10:1 = $\pm 0.075\%$ TD > 10:1 = $\pm 0.0075\% \cdot TD$	TD 1:1 = $\pm 0.05\%$ TD > 1:1 to TD 5:1 = $\pm 0.075\%$
250 mbar (3.75 psi)	TD 1:1 to 10:1 = $\pm 0.075\%$ TD > 10:1 = $\pm 0.0075\% \cdot TD$	TD 1:1 = $\pm 0.05\%$ TD > 1:1 to TD 5:1 = $\pm 0.05\%$
400 mbar (6 psi) 1 bar (15 psi)	TD 1:1 to 10:1 = $\pm 0.05\%$ TD > 10:1 = $\pm 0.005\% \cdot TD$	TD 1:1 = $\pm 0.035\%$ TD > 1:1 to TD 5:1 = $\pm 0.035\%$
2 bar (30 psi)	TD 1:1 to 10:1 = $\pm 0.05\%$ TD > 10:1 = $\pm 0.005\% \cdot TD$	TD 1:1 = $\pm 0.025\%$ TD > 1:1 to TD 5:1 = $\pm 0.035\%$
4 bar (60 psi)	TD 1:1 to 10:1 = $\pm 0.05\%$ TD > 10:1 = $\pm 0.005\% \cdot TD$	TD 1:1 = $\pm 0.025\%$ TD > 1:1 to TD 5:1 = $\pm 0.025\%$
10 bar (150 psi) 40 bar (600 psi)	TD 1:1 to 10:1 = $\pm 0.05\%$ TD > 10:1 = $\pm 0.005\% \cdot TD$	TD 1:1 = $\pm 0.035\%$ TD > 1:1 to TD 5:1 = $\pm 0.035\%$

*Measuring uncertainty for small absolute pressure measuring ranges*

The smallest extended uncertainty of measurement that can be delivered by our standards in the 0.001 to 35 mbar (0.0000145 to 0.5075 psi) range is 0.1 % of the reading + 0.004 mbar (0.000058 psi).

**Temperature effect [E2]***E2<sub>M</sub> - Main temperature error*

The output changes due to the effect of the ambient temperature [IEC 62828-1 / IEC 61298-3] with respect to the reference temperature [IEC 62828-1]. The values specify the maximum error due to min./max. ambient or process temperature conditions.

100 mbar (1.5 psi), 250 mbar (3.75 psi) and 400 mbar (6 psi) measuring cell

- Standard:  $\pm (0.07 \% \cdot TD + 0.038 \%)$
- Platinum:  $\pm (0.07 \% \cdot TD + 0.038 \%)$

High-temperature version: 100 mbar (1.5 psi), 250 mbar (3.75 psi) and 400 mbar (6 psi) measuring cell

- -20 to -10 °C (-4 to +14 °F) and +60 to +150 °C (+140 to +302 °F)
  - Standard:  $\pm (0.128 \% \cdot TD + 0.226 \%)$
  - Platinum:  $\pm (0.128 \% \cdot TD + 0.226 \%)$
- -10 to +60 °C (+14 to +140 °F)
  - Standard:  $\pm (0.088 \% \cdot TD + 1.27 \%)$
  - Platinum:  $\pm (0.88 \% \cdot TD + 1.27 \%)$

1 bar (15 psi), 2 bar (30 psi), 4 bar (60 psi), 10 bar (150 psi) and 40 bar (600 psi) measuring cell

- Standard:  $\pm (0.065 \% \cdot TD + 0.02 \%)$
- Platinum:  $\pm (0.065 \% \cdot TD + 0.02 \%)$

High-temperature version: 1 bar (15 psi), 2 bar (30 psi), 4 bar (60 psi), 10 bar (150 psi) and 40 bar (600 psi) measuring cell

- -20 to -10 °C (-4 to +14 °F) and +60 to +150 °C (+140 to +302 °F)
  - Standard:  $\pm (0.088 \% \cdot TD + 0.250 \%)$
  - Platinum:  $\pm (0.088 \% \cdot TD + 0.250 \%)$
- -10 to +60 °C (+14 to +140 °F)
  - Standard:  $\pm (0.088 \% \cdot TD + 1.17 \%)$
  - Platinum:  $\pm (0.88 \% \cdot TD + 1.17 \%)$

*E2<sub>E</sub> - Electronics error*

- 4 to 20 mA: 0.05 %
- Digital output HART: 0 %
- Digital output PROFINET: 0 %

**Resolution**

Current output: <1 µA

**Total error**

The total error of the device comprises the total performance and the long-term stability effect and is calculated using the following formula:

Total error = total performance + long-term stability

**Calculation of the total error with the Endress+Hauser Applicator**

Detailed inaccuracies, e.g. for other temperature ranges or the high-temperature version of the device can be calculated with the Applicator "[Sizing Pressure Performance](#)".



A0038927

### Long-term stability

The specifications refer to the upper range limit (URL).

Gauge pressure measuring cells

- 1 year:  $\pm 0.05\%$
- 5 years:  $\pm 0.08\%$
- 10 years:  $\pm 0.10\%$
- 15 years:  $\pm 0.11\%$

Absolute pressure measuring cells

- 1 year:  $\pm 0.05\%$
- 5 years:  $\pm 0.15\%$
- 10 years:  $\pm 0.20\%$
- 15 years:  $\pm 0.23\%$

### Response time T63 and T90

#### Dead time, time constant

Representation of dead time and time constant as per IEC62828-1:

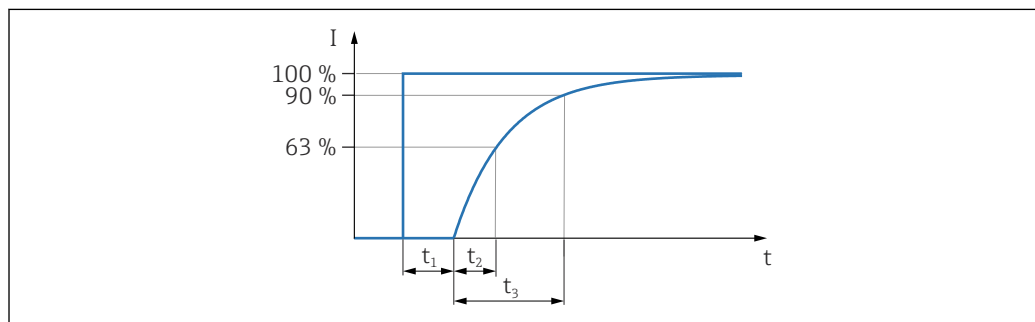

A0019786

Step response time = dead time ( $t_1$ ) + time constant T90 ( $t_3$ ) according to IEC62828-1

#### Dynamic behavior, current output

- Dead time ( $t_1$ ): maximum 50 ms
- Time constant T63 ( $t_2$ ): maximum 85 ms
- Time constant T90 ( $t_3$ ): maximum 200 ms

### Installation factors

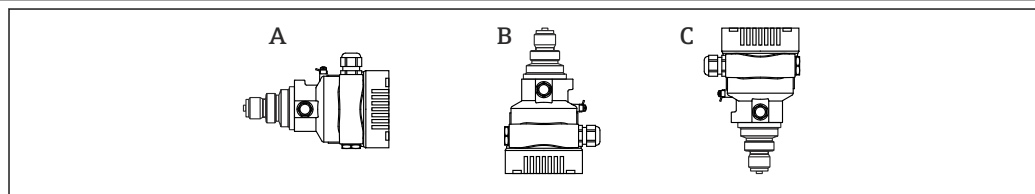

A0052060

- A: Membrane axis is horizontal: calibration position, no measurement error
- B: Membrane pointing upwards: measurement error  $\leq +0.2$  mbar (+0.003 psi)
- C: Membrane pointing downwards: measurement error  $\leq -0.2$  mbar (-0.003 psi)



A position-dependent zero point shift can be corrected on the device.

---

**Warm-up time (according to IEC62828-4)**  $\leq 5$  s

## Mounting

### Orientation

- A position-dependent zero point shift (when the vessel is empty the measured value does not display zero) can be corrected
- The use of shutoff devices and/or water pocket pipes is recommended for mounting
- The orientation depends on the measuring application

### Installation instructions

- The devices are mounted according to the same guidelines as pressure gauges (DIN EN837-2)
- To ensure optimal readability of the local display, adjust the housing and local display
- Endress+Hauser offers a mounting bracket to mount the device on pipes or walls
- Use flushing rings for flanges if there is a risk of medium buildup or clogging at the process connection
  - The flushing ring is clamped between the process connection and process
  - Material buildup in front of the membrane is flushed away, and the pressure chamber is vented, via the two lateral flushing holes
- When measuring in media containing solids (e.g. dirty liquids), installing separators and drain valves is useful for capturing and removing sediment
- Using a valve manifold allows for easy commissioning, installation and maintenance without interrupting the process
- When mounting the device, establishing the electrical connection and during operation: prevent the penetration of moisture into the housing
- Point the cable and plug downwards as much as possible to prevent moisture from entering (e.g. rainwater or condensation)

### Sensor selection and arrangement

#### Mounting the device

##### *Pressure measurement in gases*

Mount the device with the shutoff device above the tapping point so that any condensate can flow into the process.

##### *Pressure measurement in steam*

Observe the maximum permitted ambient temperature of the transmitter!

Mounting:

- Ideally, mount the device with the O-shaped siphon below the tapping point  
The device may also be mounted above the tapping point
- Fill the siphon with liquid before commissioning

Advantages of using siphons:

- Protects the measuring device from hot, pressurized media due to the formation and collection of condensate
- Attenuation of water hammer
- The defined water column only causes minimal (negligible) measured errors and minimal (negligible) thermal effects on the device



For technical data (e.g. materials, dimensions or order numbers), see the accessory document SD01553P.

##### *Pressure measurement in liquids*

Mount the device with the shutoff device below or at the same level as the tapping point.

##### *Level measurement*

- Always mount the device below the lowest measuring point
- Do not install the device at the following positions:
  - In the filling curtain
  - In the tank outlet
  - In the suction area of a pump
  - At a point in the tank which could be affected by pressure pulses from the agitator
- Mount the device downstream from a shutoff device: the calibration and function check can be carried out more easily



*Mounting bracket for device or separate housing*

The device or the separate housing can be mounted on walls or pipes (for pipes with a diameter of 1 ¼" to 2") using the mounting bracket.

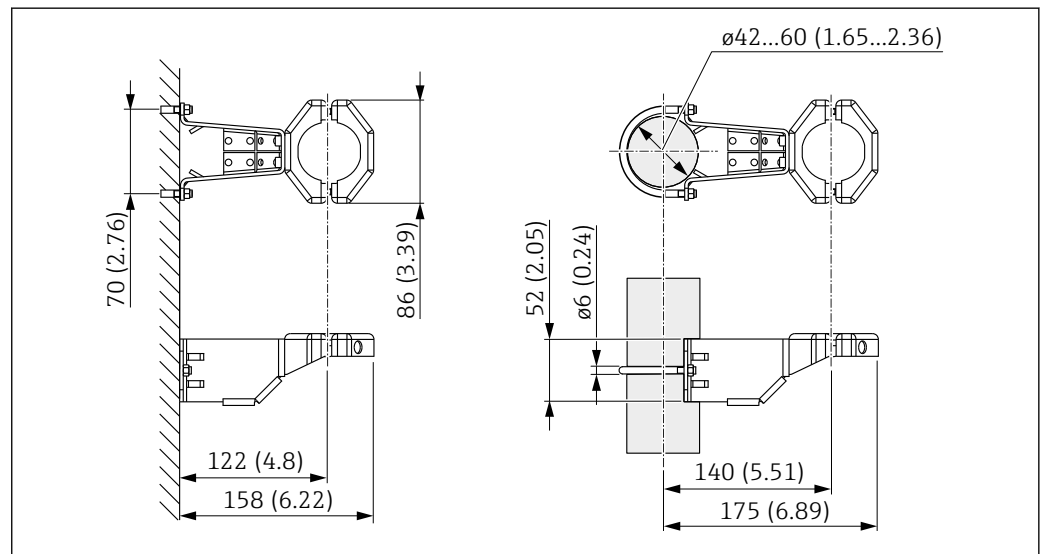

Unit of measurement mm (in)

Ordering information:

- Can be ordered via the Product Configurator
- Can be ordered as a separate accessory, part number 71102216



The mounting bracket is included in the delivery if you order the device with a separate housing.

### Special mounting instructions

#### Wall and pipe mounting with a manifold (optional)

If the device is mounted on a shutoff device (e.g. manifold or shutoff valve), then use the bracket provided for this purpose. This makes it easier to disassemble the device.

For technical data, see the SD01553P accessory document.

#### Sensor, remote (separate housing)

The device housing (including the electronic insert) is mounted at a distance from the measuring point.

This version therefore facilitates trouble-free measurement:

- Under particularly difficult measuring conditions (at installation locations that are cramped or difficult to access)
- If the measuring point is exposed to vibrations

Cable versions:

- PE: 2 m (6.6 ft), 5 m (16 ft) and 10 m (33 ft)
- FEP: 5 m (16 ft).

The sensor is delivered with the process connection and cable already mounted. The housing (including the electronic insert) and a mounting bracket are enclosed as separate units. The cable is provided with a socket at both ends. These sockets are simply connected to the housing (including the electronic insert) and the sensor.

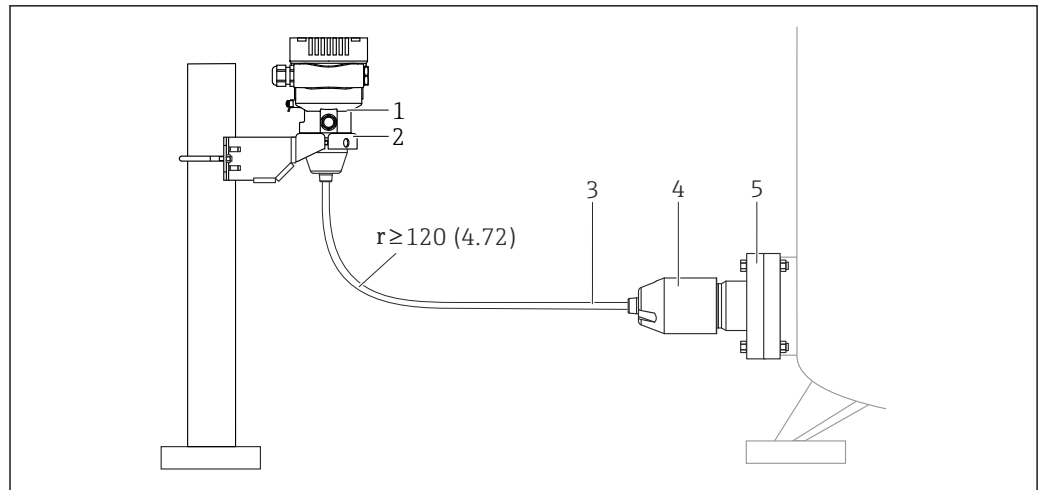

A0038412

- 1 Sensor, remote (including electronic insert)
- 2 Mounting bracket enclosed, suitable for wall or pipe mounting
- 3 Cable, both ends are fitted with a socket
- 4 Process connection adapter
- 5 Process connection with sensor

#### Ordering information:

- Remote sensor (including electronic insert) including the mounting bracket can be ordered via the Product Configurator
- The mounting bracket can also be ordered as a separate accessory, part number 71102216

#### Technical data for cables:

- Minimum bending radius: 120 mm (4.72 in)
- Cable extraction force: max. 450 N (101.16 lbf)
- Resistance to UV light

#### Use in hazardous area:

- Intrinsically safe installations (Ex ia/IS)
- FM/CSA IS for Div. 1 installation only

#### Reduction of installation height

If this version is used, the installation height of the process connection is reduced compared to the dimensions of the standard version.

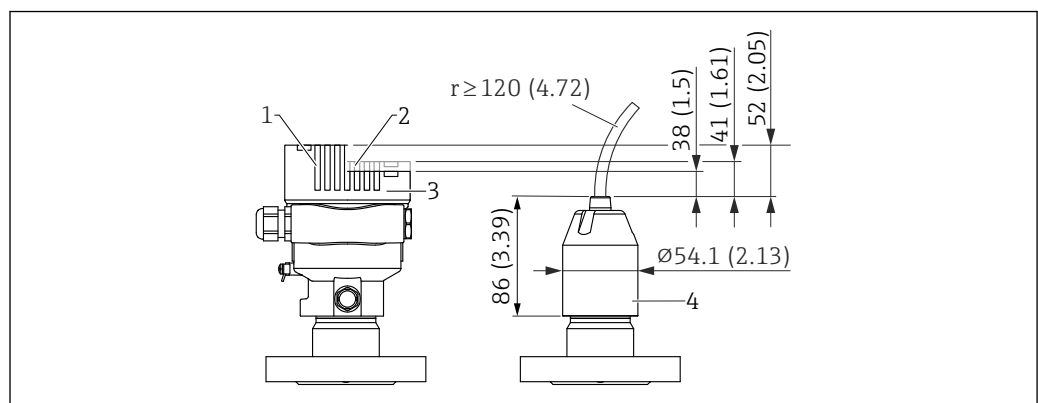

A0047094

- 1 Device with display, cover with glass viewing window (devices for Ex d, dust Ex)
- 2 Device with display, cover with plastic viewing window
- 3 Device without display, cover without viewing window
- 4 Process connection adapter

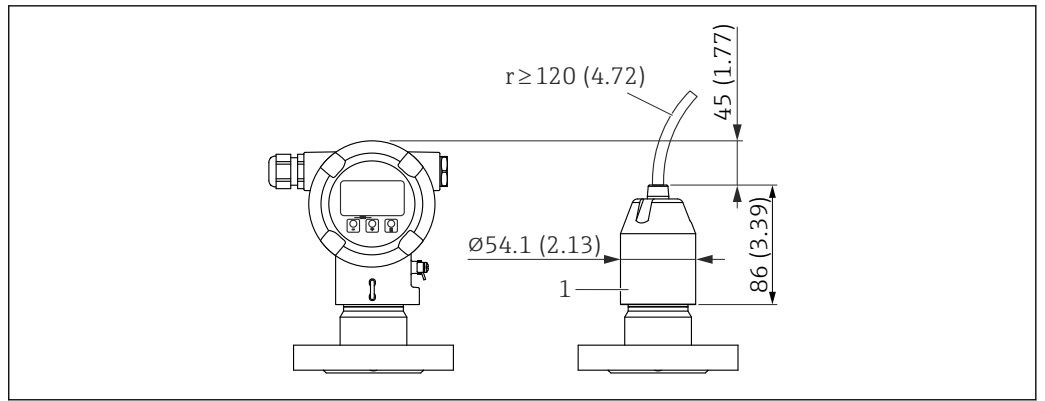

1 Process connection adapter

## Environment

<b>Ambient temperature range</b>	<p>The following values apply up to a process temperature of +85 °C (+185 °F). At higher process temperatures, the permitted ambient temperature is reduced.</p> <ul style="list-style-type: none"> <li>■ Without segment display or graphic display: Standard: -40 to +85 °C (-40 to +185 °F)</li> <li>■ With segment display or graphic display: -40 to +85 °C (-40 to +185 °F) with limitations in optical properties such as display speed and contrast. Can be used without limitations up to -20 to +60 °C (-4 to +140 °F) Segment display: up to -50 to +85 °C (-58 to +185 °F) with restricted operating life and performance</li> <li>■ Separate housing: -20 to +60 °C (-4 to +140 °F)</li> </ul>
	<p><b>Hazardous area</b></p> <ul style="list-style-type: none"> <li>■ For devices for use in hazardous areas, see the Safety Instructions, Installation Drawing or Control Drawing</li> <li>■ Devices that have the most common explosion protection certificates (e.g. ATEX/ IEC Ex, etc.) can be used in explosive atmospheres up to the ambient temperature.</li> </ul>
<b>Storage temperature</b>	<ul style="list-style-type: none"> <li>■ Without LCD display: Standard: -40 to +90 °C (-40 to +194 °F)</li> <li>■ With LCD display: -40 to +85 °C (-40 to +185 °F)</li> <li>■ Separate housing: -40 to +60 °C (-40 to +140 °F)</li> </ul> <p>With M12 plug, elbowed: -25 to +85 °C (-13 to +185 °F)</p>
<b>Operating altitude</b>	Up to 5 000 m (16 404 ft) above sea level.
<b>Climate class</b>	<p>Class 4K4H (air temperature: -20 to +55 °C (-4 to +131 °F), relative humidity: 4 to 100 %) satisfied as per DIN EN 60721-3-4.</p> <p>Condensation is possible.</p>
<b>Degree of protection</b>	Test as per IEC 60529 and NEMA 250-2014

### Housing and process connection

IP66/68, TYPE 4X/6P  
(IP68: (1.83 mH<sub>2</sub>O for 24 h))

### Cable entries

- Gland M20, plastic, IP66/68 TYPE 4X/6P
- Gland M20, brass nickel plated, IP66/68 TYPE 4X/6P
- Gland M20, 316L, IP66/68 TYPE 4X/6P
- Thread M20, IP66/68 TYPE 4X/6P
- Thread G1/2, IP66/68 TYPE 4X/6P  
If the G1/2 thread is selected, the device is delivered with an M20 thread as standard and a G1/2 adapter is included with the delivery, along with the corresponding documentation
- Thread NPT1/2, IP66/68 TYPE 4X/6P
- Dummy plug transport protection: IP22, TYPE 2
- Plug HAN7D, 90 deg. IP65 NEMA Type 4X
- Plug M12  
When housing is closed and connecting cable is plugged in: IP66/67 NEMA Type 4X  
When housing is open or connecting cable is not plugged in: IP20, NEMA Type 1

### NOTICE

#### Plug M12 and plug HAN7D: incorrect mounting can invalidate the IP protection class!

- ▶ The degree of protection only applies if the connecting cable used is plugged in and screwed tight.
- ▶ The degree of protection only applies if the connecting cable used is specified according to IP67 NEMA Type 4X.
- ▶ The IP protection classes are only maintained if the dummy cap is used or the cable is connected.

**Process connection and process adapter when using the separate housing**

*FEP cable*

- IP69 (on sensor side)
- IP66 TYPE 4/6P
- IP68 (1.83 mH<sub>2</sub>O for 24 h) TYPE 4/6P

*PE cable*

- IP69 (on sensor side)
- IP66 TYPE 4/6P
- IP68 (1.83 mH<sub>2</sub>O for 24 h) TYPE 4/6P

**Vibration resistance**

**Single compartment housing**

Mechanical construction	Sine wave oscillation IEC62828-1 / IEC61298-3	Shock
Device	10 Hz to 60 Hz: ±0.35 mm (0.0138 in) 60 Hz to 1000 Hz: 5 g	30 g
High-temperature device version <sup>1)</sup>	10 Hz to 60 Hz: ±0.15 mm (0.0059 in) 60 Hz to 1000 Hz: 2 g	30 g
Device with Ex d and XP version <sup>2)</sup>	10 Hz to 60 Hz: ±0.15 mm (0.0059 in) 60 Hz to 1000 Hz: 2 g	30 g

- 1) Non-flush process connections with a thread are limited to 10 Hz-150 Hz 0.2 g.  
 2) Not for the high-temperature version with Ex d and XP.

**Aluminum dual compartment housing**

Mechanical construction	Sine wave oscillation IEC62828-1 / IEC61298-3	Shock
Device	10 Hz to 60 Hz: ±0.15 mm (0.0059 in) 60 Hz to 1000 Hz: 2 g	30 g
High-temperature device version <sup>1)</sup>	10 Hz to 60 Hz: ±0.15 mm (0.0059 in) 60 Hz to 1000 Hz: 2 g	30 g
Device with Ex d version <sup>2)</sup>	10 Hz to 60 Hz: ±0.15 mm (0.0059 in) 60 Hz to 1000 Hz: 2 g	30 g

- 1) Non-flush process connections with a thread are limited to 10 Hz-150 Hz 0.2 g.  
 2) Not for the high-temperature version with Ex d and XP.

**Stainless steel dual compartment housing**

Mechanical construction	Sine wave oscillation IEC62828-1 / IEC61298-3	Shock
Device	10 Hz to 60 Hz: ±0.15 mm (0.0059 in) 60 Hz to 1000 Hz: 2 g	15 g
High-temperature device version	10 Hz to 150 Hz: 0.2 g	15 g
Device with Ex d version <sup>1)</sup>	10 Hz to 150 Hz: 0.2 g	15 g

- 1) Not for the high-temperature version with Ex d and XP.

**Electromagnetic compatibility (EMC)**

- Electromagnetic compatibility as per EN 61326 series and NAMUR recommendation EMC (NE21)
- With regard to the safety function (SIL), the requirements of EN 61326-3-x are satisfied
- Maximum deviation with interference influence: < 0.5% of span with full measuring range (TD 1:1)

For more details refer to the EU Declaration of Conformity.

## Process

### Process temperature range

#### NOTICE

The permitted process temperature depends on the process connection, process seal, ambient temperature and the type of approval.

- ▶ All the temperature data in this document must be taken into consideration when selecting the device.

The process temperature ranges indicated refer to the permanent operation of the device (maximum 5 °C (41 °F) deviation is permitted)

-40 to +125 °C (-40 to +257 °F)

High-temperature version: -25 to +150 °C (-13 to +302 °F)

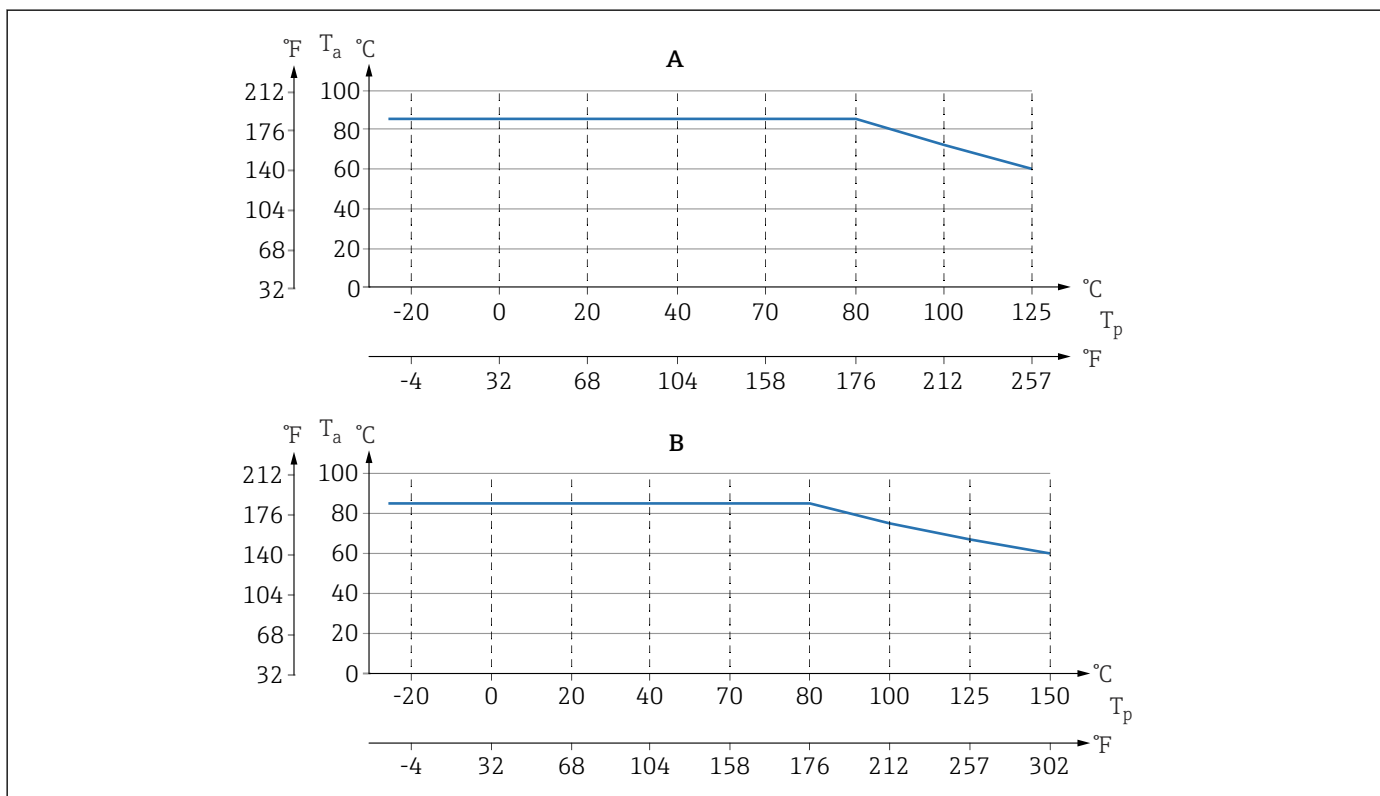

A0043557

5 Values apply for vertical mounting without insulation.

A All versions except B

B "High-temperature version"

T<sub>p</sub> Process temperature

T<sub>a</sub> Ambient temperature

### Seals

Pay attention to the process temperature range of the seal. The temperatures indicated depend on the resistance of the seal to the medium.

Seal	Temperature	Temperature High-temperature version
FKM	-25 to +150 °C (-13 to +302 °F)	-
FKM Cleaned for oxygen service	-10 to +60 °C (+14 to +140 °F)	-
FFKM Perlast G75LT	-20 to +125 °C (-4 to +257 °F)	-20 to +150 °C (-4 to +302 °F)
FFKM Kalrez 6375	+5 to +125 °C (+41 to +257 °F)	+5 to +150 °C (+41 to +302 °F)
FFKM Chemraz 505	-10 to +125 °C (+14 to +257 °F)	-10 to +150 °C (+14 to +302 °F)

Seal	Temperature	Temperature High-temperature version
EPDM	-40 to +125 °C (-40 to +257 °F)	-25 to +150 °C (-13 to +302 °F)
HNBR	-25 to +125 °C (-13 to +257 °F)	-

### Standard device (without diaphragm seal)

#### Oxygen applications (gaseous)

Oxygen and other gases can react explosively to oils, grease and plastics. The following precautions must be taken:

- All components of the system, such as devices, must be cleaned in accordance with the national requirements.
- Depending on the materials used, a certain maximum temperature and a maximum pressure must not be exceeded for oxygen applications.

The cleaning of the device (not accessories) is offered as an optional service.

Devices with measuring cells, nominal value < 10 bar (150 psi)

- $p_{max}$ : overpressure limit (OPL) of the measuring cell and depending on the process connection used
- Devices with PVDF threads:
  - Only mount with the enclosed mounting bracket!
  - $p_{max}$ : 15 bar (225 psi)
  - $T_{max}$ : 60 °C (140 °F)

Devices with measuring cells, nominal value  $\geq$  10 bar (150 psi)

- $p_{max}$ : 40 bar (600 psi)
- $T_{max}$ : 60 °C (140 °F)

### Thermal shock

#### Applications with jumps in temperature

Extreme jumps in temperature can result in temporary measuring errors. Temperature compensation takes place after a few minutes. Internal temperature compensation is faster the smaller the jump in temperature and the longer the time interval involved.



For more information: contact the Endress+Hauser sales office.

### Process pressure range

#### Pressure specifications

##### WARNING

**The maximum pressure for the device depends on the lowest-rated component with regard to pressure (components are: process connection, optional mounted parts or accessories).**

- ▶ Only operate the device within the specified limits for the components!
- ▶ MWP (maximum working pressure): The MWP is specified on the nameplate. This value refers to a reference temperature of +20 °C (+68 °F) and may be applied to the device for an unlimited time. Note temperature dependence of MWP. For flanges, refer to the following standards for the permitted pressure values at higher temperatures: EN 1092-1 (with regard to their stability/temperature property, the materials 1.4435 and 1.4404 are grouped together under EN 1092-1; the chemical composition of the two materials can be identical.), ASME B 16.5a, JIS B 2220 (the latest version of the standard applies in each case). MWP data that deviate from this are provided in the relevant sections of the Technical Information.
- ▶ The overpressure limit is the maximum pressure a device may be subjected to during a test. It is greater than the maximum working pressure by a certain factor. This value refers to a reference temperature of +20 °C (+68 °F).
- ▶ The Pressure Equipment Directive (2014/68/EU) uses the abbreviation "PS". The abbreviation "PS" corresponds to the MWP (maximum working pressure) of the device.
- ▶ In the case of measuring cell range and process connection combinations where the overpressure limit (OPL) of the process connection is smaller than the nominal value of the measuring cell, the device is set at the factory, at the very maximum, to the OPL value of the process connection. If the entire measuring cell range must be used, select a process connection with a higher OPL value ( $1.5 \times PN$ ;  $MWP = PN$ ).
- ▶ Oxygen applications: do not exceed values for  $P_{max}$  and  $T_{max}$ .

**Burst pressure**

As of the specified burst pressure, the complete destruction of the pressure-bearing parts and/or a device leak must be expected. It is therefore imperative to avoid such operating conditions by carefully planning and sizing your facility.

---

**Ultrapure gas applications**

Endress+Hauser also offers devices for special applications, such as for ultrapure gas, that are cleaned of oil and grease. No special restrictions regarding the process conditions apply to these devices.

---

**Steam applications and saturated steam applications**

For steam and saturated steam applications: Use a device with a metallic membrane or provide a water pocket pipe for temperature decoupling when installing.



## Mechanical construction



For the dimensions, see the Product Configurator: [www.endress.com](http://www.endress.com)

Search for product → Start configuration → after configuration, click "CAD"

The following dimensions are rounded values. For this reason, the dimensions may deviate from the values on [www.endress.com](http://www.endress.com).

### Design, dimensions

#### Device height

The device height is calculated from

- the height of the housing
- the height of the individual process connection

The individual heights of the components can be found in the following sections. To calculate the device height, add the individual heights of the components. Take the installation clearance into consideration (space that is used to install the device).

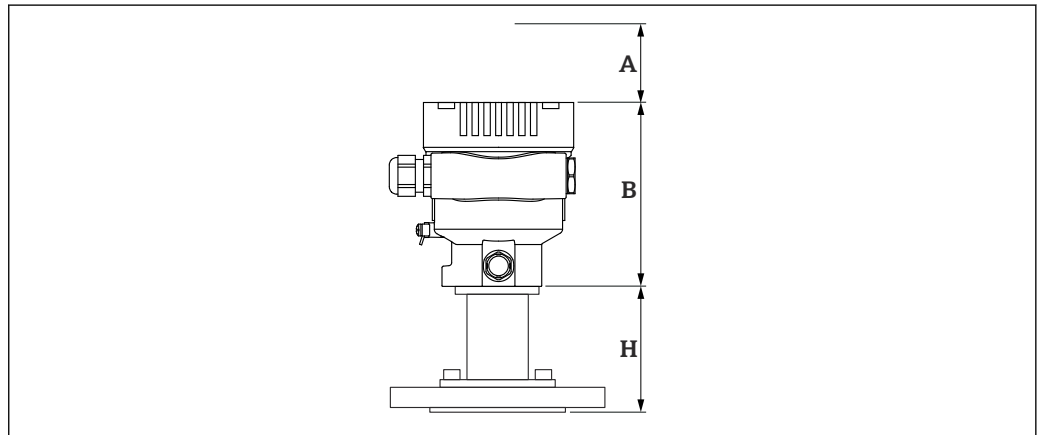

A0043569

- A *Installation clearance*  
 B *Height of the housing*  
 H *Height of the process connection*

## Dimensions

## Single compartment housing

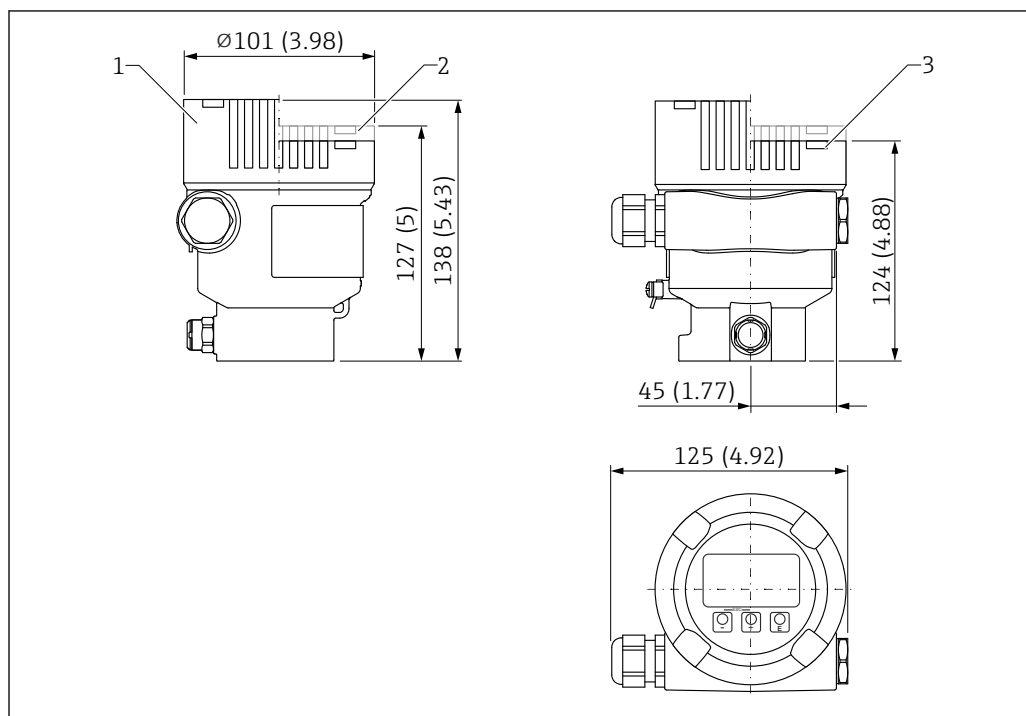

A0038380

Unit of measurement mm (in)

- 1 Device with display, cover with glass viewing window (devices for Ex d/XP, dust Ex): 138 mm (5.43 in)
- 2 Device with display, cover with plastic viewing window: 127 mm (5 in)
- 3 Device without display, cover without viewing window: 124 mm (4.88 in)



Cover optionally with ANSI Safety Red (color RAL3002) coating.

Dual compartment housing

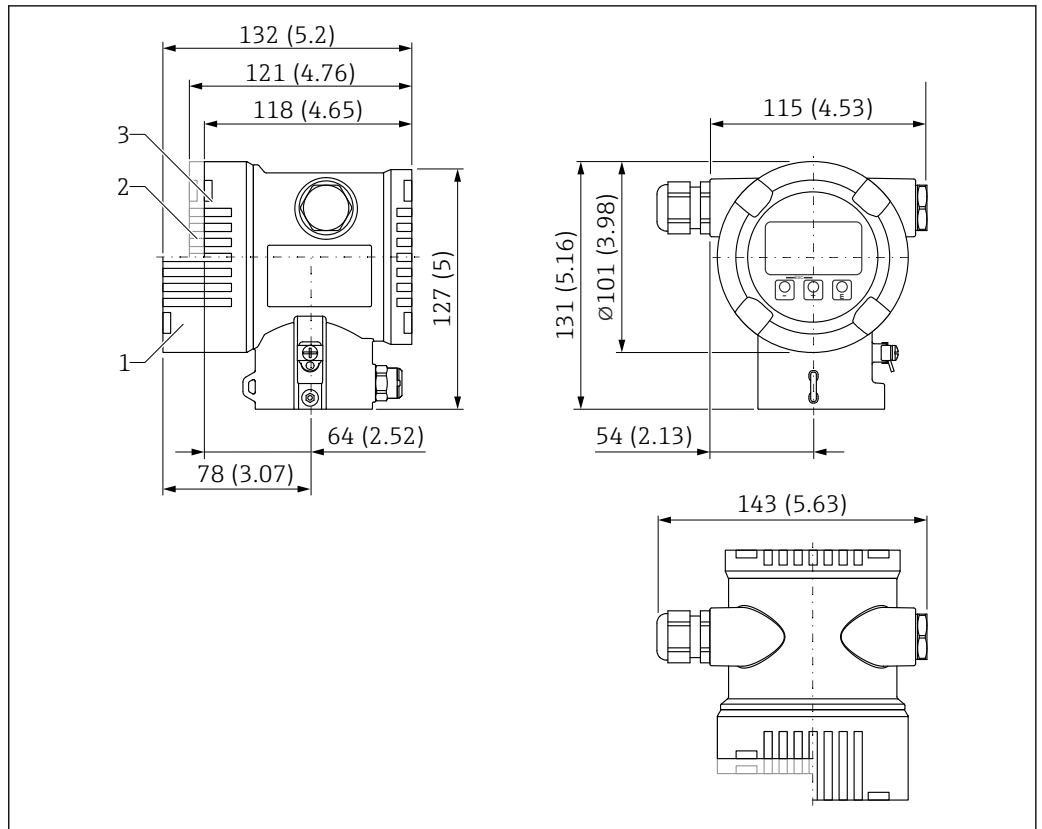

A0038377

Unit of measurement mm (in)

- 1 Device with display, cover with glass viewing window (devices for Ex d/XP, dust Ex): 132 mm (5.2 in)
- 2 Device with display, cover with plastic viewing window: 121 mm (4.76 in)
- 3 Device without display, cover without viewing window: 118 mm (4.65 in)

 Cover optionally with ANSI Safety Red (color RAL3002) coating.

## Sensor, remote (separate housing)

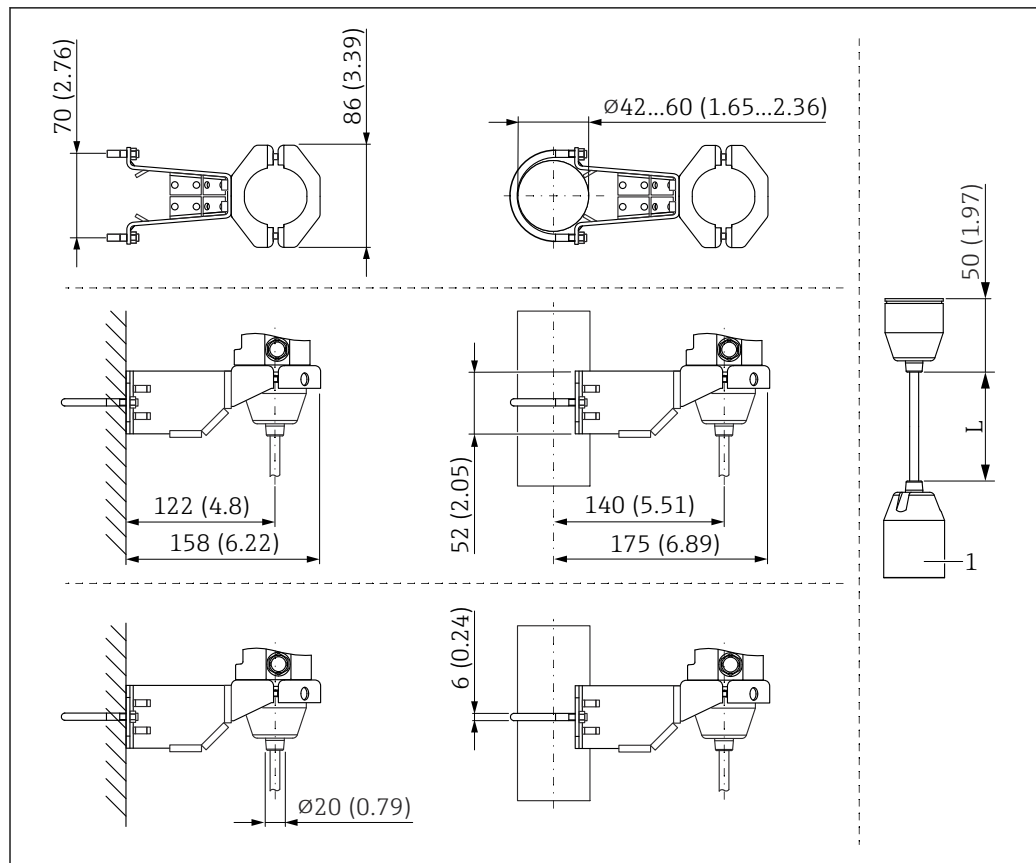

A0038214

Unit of measurement mm (in)

1 86 mm (3.39 in)

L Length of cable versions

**OPL and MWP**

The maximum overpressure limit (OPL) and the maximum working pressure (MWP) of the sensor can deviate from the maximum OPL and MWP of the process connection.

For the maximum OPL and MWP, see the technical documentation of the process connection.

**Explanation of terms**

- DN or NPS or A = alphanumeric designation of the flange size
- PN or Class or K = alphanumeric pressure rating of a component

Height H

Process connection	Height H	
	Standard	Ex d version
FNPT1/2 MNPT1/2 MNPT1/2 FNPT1/4 G1/2 M20x1.5 B0202 B0203	28 mm (1.1 in)	94 mm (3.7 in)
MNPT1-1/2 MNPT2 G1-1/2 G2 M44x1.25	59 mm (2.32 in)	125 mm (4.92 in)
Flanges	83 mm (3.27 in)	150 mm (5.91 in)

Process connection	Height H	
	High-temperature version	Ex d high-temperature version
FNPT1/2 MNPT1/2 MNPT1/2 FNPT1/4 G1/2 M20x1.5 B0202 B0203	107 mm (4.21 in)	173 mm (6.81 in)
MNPT1-1/2 MNPT2 G1-1/2 G2 M44x1.25	59 mm (2.32 in)	125 mm (4.92 in)
Flanges	83 mm (3.27 in)	150 mm (5.91 in)

Thread ISO228 G, internal membrane

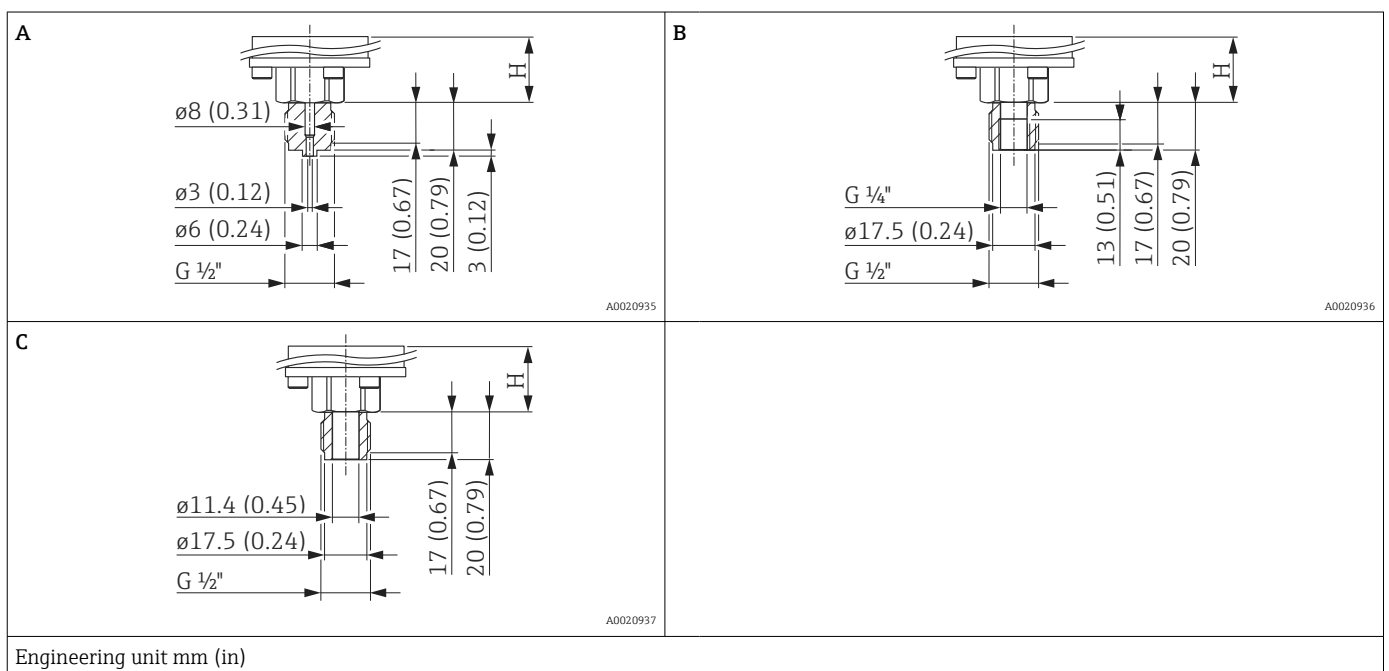

Item	Designation	Material	Weight <sup>1)</sup>
			kg (lb)
A	Thread ISO228 G 1/2" A EN837	AISI 316L	0.60 (1.32)
		Alloy C276 (2.4819)	
		<b>PVDF</b> <ul style="list-style-type: none"> <li>Only mount with a mounting bracket (included)</li> <li>MWP 10 bar (150 psi), OPL max. 15 bar (225 psi)</li> <li>Process temperature range: -10 to +60 °C (+14 to +140 °F)</li> </ul>	
B	Thread ISO228 G 1/2" A, G 1/4" (female)	AISI 316L	
		Alloy C276 (2.4819)	
C	Thread ISO228 G 1/2" A, Bore 11.4 mm (0.45 in)	AISI 316L	
		Alloy C276 (2.4819)	

1) Total weight consisting of sensor assembly and process connection.

**Thread ASME B1.20.1, NPT, internal membrane**

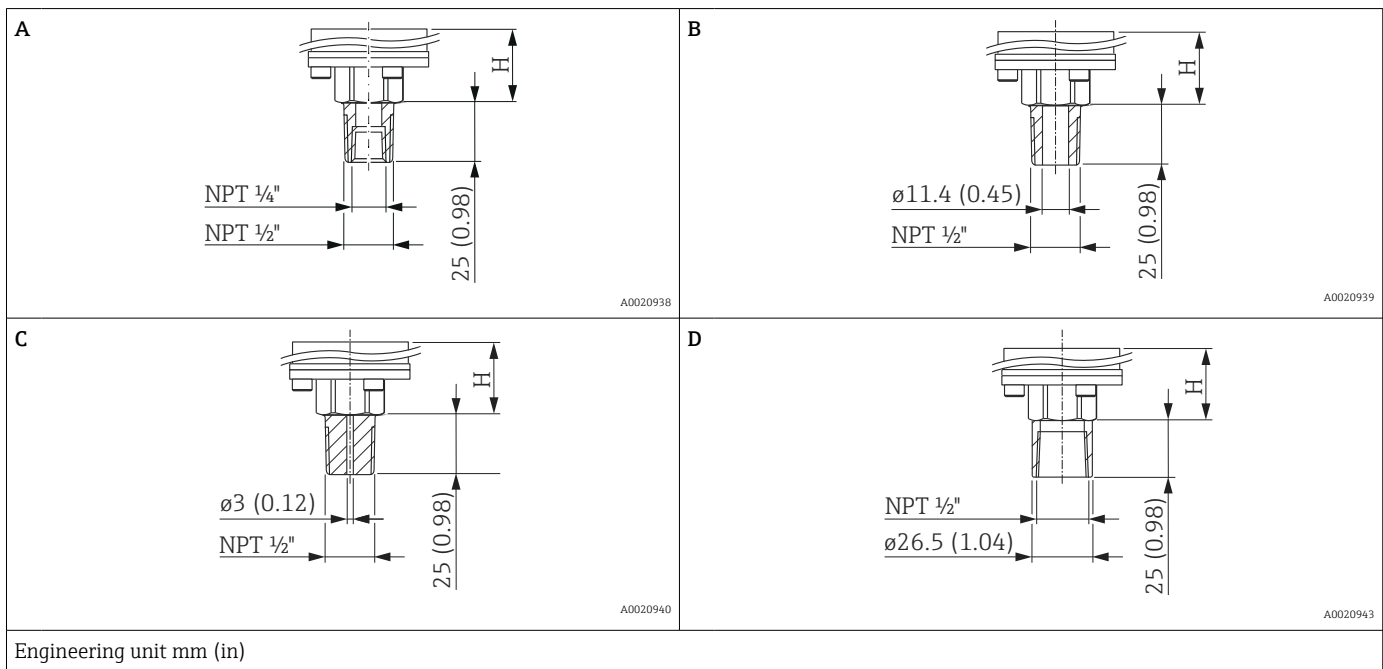

Item	Designation	Material	Weight <sup>1)</sup>
			kg (lb)
A <sup>2)</sup>	Thread ASME MNPT 1/2", FNPT 1/4"	AISI 316L	
		Alloy C276 (2.4819)	
B	Thread ASME MNPT 1/2", Bore 11.4 mm (0.45 in)	AISI 316L	
		Alloy C276 (2.4819)	
C	Thread ASME MNPT 1/2", Bore 3 mm (0.12 in)	<b>PVDF</b> <ul style="list-style-type: none"> <li>Only mount with a mounting bracket (included)</li> <li>MWP 10 bar (150 psi), OPL max. 15 bar (225 psi)</li> <li>Process temperature range: -10 to +60 °C (+14 to +140 °F)</li> </ul>	0.60 (1.32)
D	Thread ASME FNPT 1/2"	AISI 316L	
		Alloy C276 (2.4819)	

1) Total weight consisting of sensor assembly and process connection.

2) URL max. 100 bar (1 500 psi)

Thread JIS, internal membrane

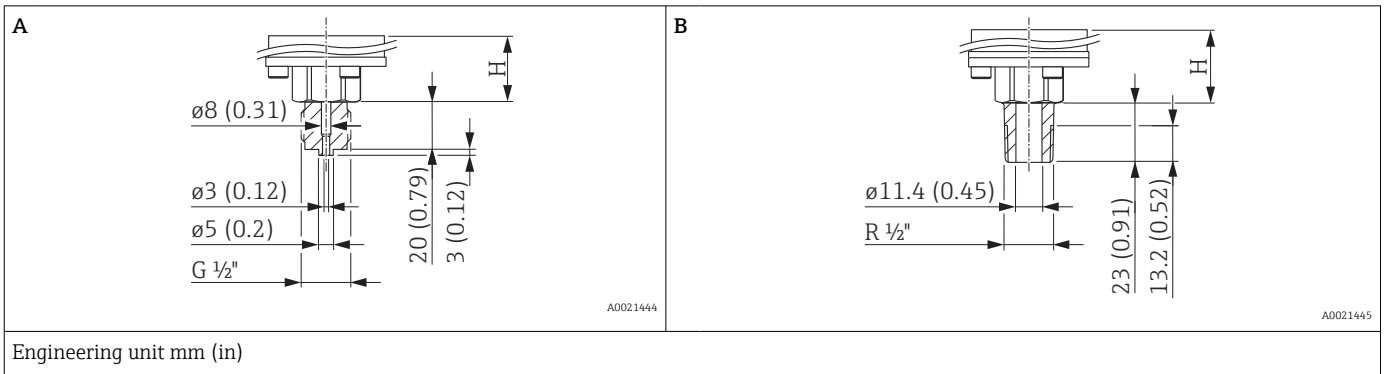

Item	Designation	Material	Weight <sup>1)</sup>
			kg (lb)
A	JIS B0202 G 1/2" (male)	AISI 316L	0.60 (1.32)
B	JIS B0203 R 1/2" (male)		

1) Total weight consisting of sensor assembly and process connection.

Thread, metric (DIN 13), internal membrane

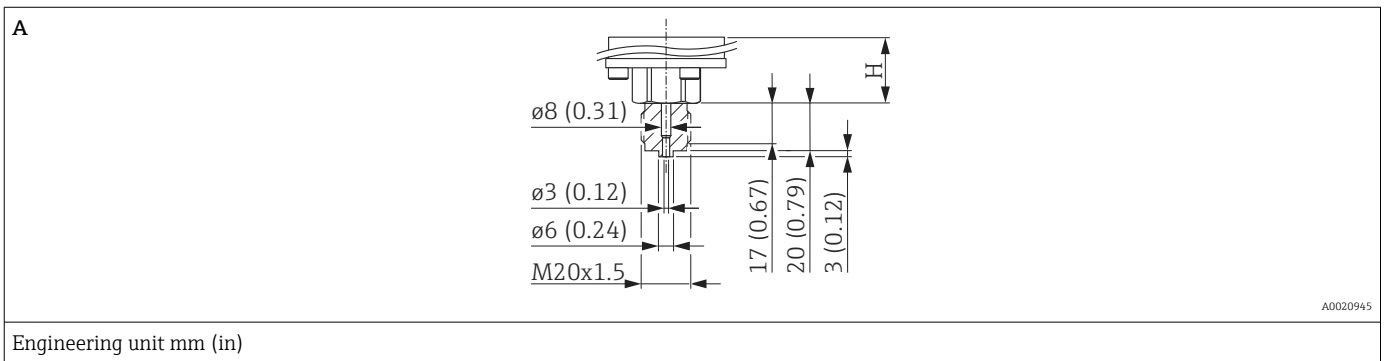

Item	Designation	Material	Weight <sup>1)</sup>
			kg (lb)
A	DIN 13 M20 x 1.5, EN837 3 mm (0.12 in)	AISI 316L	0.60 (1.32)
		Alloy C276 (2.4819)	

1) Total weight consisting of sensor assembly and process connection.

Thread ISO228 G, flush membrane

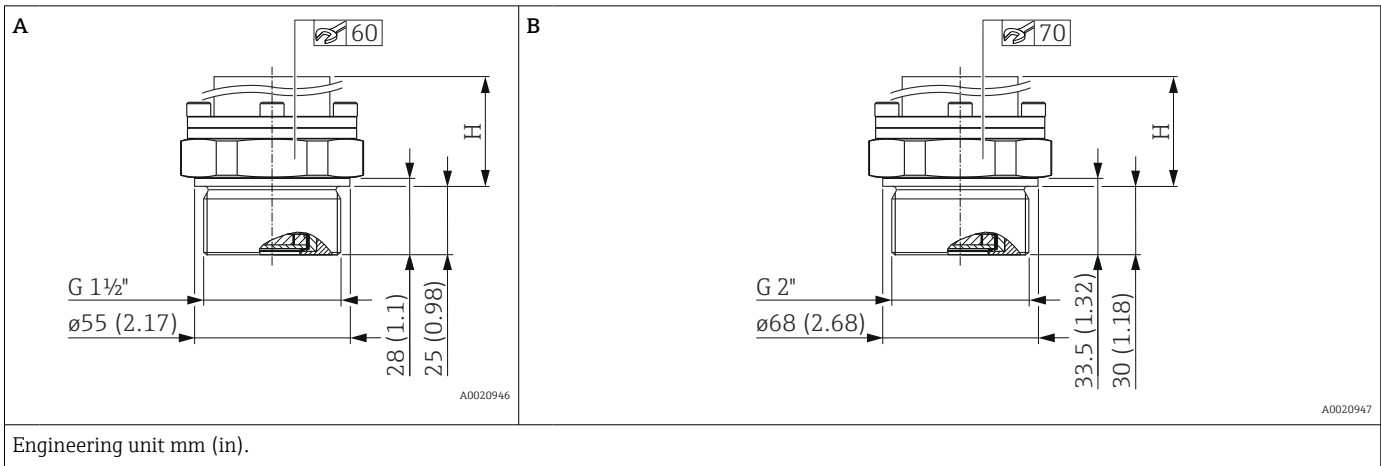

Item	Designation	Material	Weight <sup>1)</sup>
			kg (lb)
A	Thread ISO228 G 1 1/2" A	AISI 316L	0.8 (1.76)
		Alloy C276 (2.4819)	0.9 (1.98)
B	Thread ISO228 G 2" A	AISI 316L	1.2 (2.65)
		Alloy C276 (2.4819)	1.2 (2.65)

1) Total weight consisting of sensor assembly and process connection.

Thread ASME, NPT, flush membrane

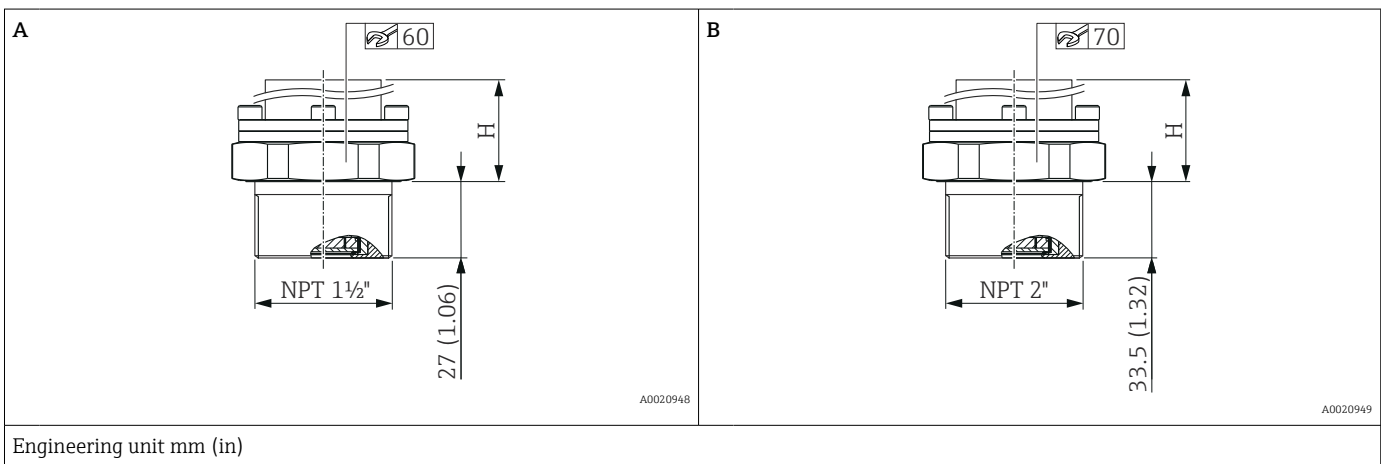

Item	Designation	Material	Weight <sup>1)</sup>
			kg (lb)
A	Thread ASME 1 1/2" MNPT	AISI 316L	0.80 (1.76)
B	Thread ASME 2" MNPT	AISI 316L	1.20 (2.65)

1) Total weight consisting of sensor assembly and process connection.



Thread DIN 13, flush membrane

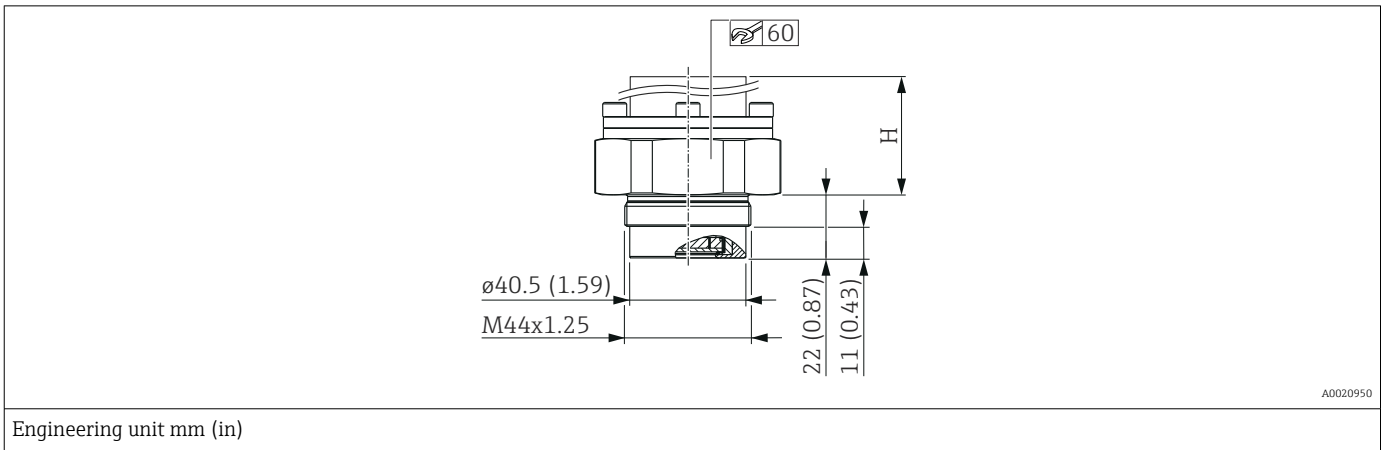

Designation	Material	Weight <sup>1)</sup>
		kg (lb)
DIN 13 M44 x 1.25	AISI 316L	0.90 (1.98)
	Alloy C276 (2.4819)	

1) Total weight consisting of sensor assembly and process connection.

**Flange EN1092-1, flush membrane**

Connection dimensions according to EN1092-1.

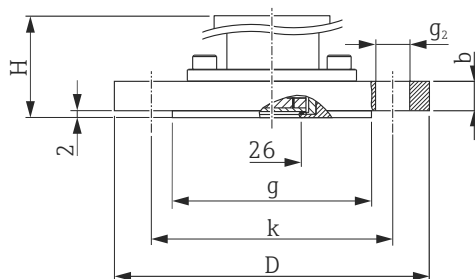

A0020955

*D* Diameter of flange  
*b* Thickness  
*g* Raised face  
*k* Pitch diameter  
*g<sub>2</sub>* Diameter of hole

Engineering unit mm

Flange							Boltholes			Weight <sup>1)</sup>	
Material	DN	PN	Form	D	b	g	Quantity	g <sub>2</sub>	k		
				mm	mm	mm				mm	mm
AISI 316L	DN 25	PN 10-40	B1	115	18	68	4	14	85	1.9 (4.19)	
AlloyC22	DN25	PN 10-40	B1	115	18	68	4	14	85	2.0 (4.41)	
AISI 316L	DN 32	PN 10-40	B1	140	18	78	4	18	100	2.5 (5.51)	
AISI 316L	DN 40	PN 10-40	B1	150	18	88	4	18	110	3.0 (6.62)	
PVDF <sup>2) 3)</sup>	DN 40	PN 10-16	B2	150	21.4	88	4	18	110	1.3 (2.87)	
ETFE <sup>3)</sup>	DN 40	PN 10-40	B2	150	21	88	4	18	110	3.0 (6.62)	
AISI 316L	DN 50	PN 10-40	B1	165	20	102	4	18	125	3.5 (7.72)	
AlloyC22	DN 50	PN 10-40	B1	165	20	102	4	18	125	3.8 (8.38)	
PVDF <sup>2) 3)</sup>	DN 50	PN 10-16	B2	165	21.4	102	4	18	125	1.4 (3.09)	
ETFE <sup>3)</sup>	DN 50	PN 25-40	B2	165	21	102	4	18	125	3.7 (8.16)	
AISI 316L	DN 80	PN 10-40	B1	200	24	138	8	18	160	5.8 (12.79)	
ETFE <sup>3)</sup>	DN 80	PN 25-40	B2	200	25	138	8	18	160	5.2 (11.47)	

1) Total weight consisting of sensor assembly and process connection.

2) MWP 10 bar (150 psi), OPL max. 15 bar (225 psi); process temperature range: -10 to +60 °C (+14 to +140 °F)

3) ETFE coating on AISI 316L (1.4404). When using in hazardous areas: avoid electrostatic charge on the plastic surfaces.

**Flange ASME B16.5, RF, flush membrane**

Connection dimensions in accordance with ASME B16.5, raised face RF

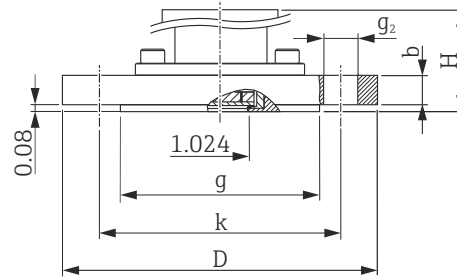

A0034685

- $D$  Diameter of flange
- $b$  Thickness
- $g$  Raised face
- $k$  Pitch diameter
- $g_2$  Diameter of hole

Engineering unit in

Flange						Boltholes			Weight <sup>1)</sup>
Material	NPS	Class	D	b	g	Quantity	$g_2$	k	
	in		in	in	in		in	in	kg (lb)
AISI 316/316L <sup>2) 3)</sup>	1	150	4.25	1.18	2	4	0.62	3.12	2.3 (5.07)
AISI 316/316L <sup>2) 3)</sup>	1	300	4.88	1.18	2	4	0.75	3.5	8.5 (18.74)
AISI 316/316L <sup>2)</sup>	1 ½	150	5	0.69	2.88	4	0.62	3.88	2.1 (4.63)
AISI 316/316L <sup>2)</sup>	1 ½	300	6.12	0.81	2.88	4	0.88	4.5	3.3 (7.28)
AISI 316/316L <sup>2)</sup>	2	150	6	0.75	3.62	4	0.75	4.75	3.1 (6.84)
ETFE <sup>4)</sup>	2	150	6	0.75	3.62	4	0.75	4.75	3.1 (6.84)
AISI 316/316L <sup>2)</sup>	2	300	6.5	0.88	3.62	8	0.75	5	4.0 (8.82)
AISI 316/316L <sup>2)</sup>	3	150	7.5	0.94	5	4	0.75	6	5.7 (12.57)
ETFE <sup>4)</sup>	3	150	7.5	0.94	5	4	0.75	6	5.7 (12.57)
PVDF <sup>5)</sup>	3	150	7.5	0.94	5	4	0.75	6	1.6 (3.53)
AISI 316/316L <sup>2)</sup>	3	300	8.25	1.12	5	8	0.88	6.62	7.5 (16.54)
AISI 316/316L <sup>2)</sup>	4	150	9	0.94	6.19	8	0.75	7.5	7.6 (16.76)
ETFE <sup>4)</sup>	4	150	9	0.94	6.19	8	0.75	7.5	7.8 (17.20)
AISI 316/316L <sup>2)</sup>	4	300	10	1.25	6.19	8	0.88	7.88	12.4 (27.34)

- 1) Total weight consisting of sensor assembly and process connection.
- 2) Combination of AISI 316 for required pressure resistance and AISI 316L for required chemical resistance (dual rated)
- 3) Screws must be 15 mm (0.59 in) longer than the standard flange screws
- 4) ETFE coating on AISI 316/316L. When using in hazardous areas: avoid electrostatic charge on the plastic surfaces.
- 5) MWP 10 bar (150 psi), OPL max. 15 bar (225 psi); process temperature range: -10 to +60 °C (+14 to +140 °F)

**Flange JIS B2220, RF, flush membrane**

Connection dimensions in accordance with JIS B 2220 BL, raised face RF

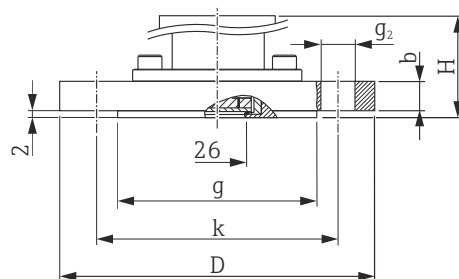

A0034684

*D* Diameter of flange  
*b* Thickness  
*g* Raised face  
*k* Pitch diameter  
*g<sub>2</sub>* Diameter of hole

Engineering unit mm

Flange						Boltholes			Weight <sup>1)</sup>
Material	A <sup>2)</sup>	K <sup>3)</sup>	D	b	g	Quantity	g <sub>2</sub>	k	
			mm	mm	mm		mm	mm	kg (lb)
AISI 316L (1.4435)	40 A	10 K	140	16	81	4	19	105	2.5 (5.51)
	50 A	10 K	155	16	96	4	19	120	2.9 (6.39)
	80 A	10 K	185	18	127	8	19	150	3.9 (8.60)
	100 A	10 K	210	18	151	8	19	175	5.3 (11.69)

- 1) Total weight consisting of sensor assembly and process connection.  
 2) Alphanumeric designation of the flange size.  
 3) Alphanumeric pressure rating of a component.

**Weight****Housing**

Weight including electronics and display.

- Single compartment housing: 1.1 kg (2.43 lb)
- Dual compartment housing
  - Aluminum: 1.4 kg (3.09 lb)
  - Stainless steel: 3.3 kg (7.28 lb)

**Sensor, remote (separate housing)**

- Housing: see the Housing section
- Housing adapter: 0.55 kg (1.21 lb)
- Process connection adapter: 0.36 kg (0.79 lb)
- Cable:
  - PE cable, 2 meters: 0.18 kg (0.40 lb)
  - PE cable, 5 meters: 0.35 kg (0.77 lb)
  - PE cable, 10 meters: 0.64 kg (1.41 lb)
  - FEP cable, 5 meters: 0.62 kg (1.37 lb)
- Mounting bracket: 0.46 kg (1.01 lb)

**Process connections**

Weight, see the specific process connection.

- Ex d version: 0.63 kg (1.39 lb)
- High-temperature version: 0.52 kg (1.15 lb)

**Accessories**

Mounting bracket: 0.5 kg (1.10 lb)

**Materials in contact with process****Membrane material**

Al<sub>2</sub>O<sub>3</sub> Aluminum-oxide ceramic, ultrapure 99.9 %, Ceraphire® (see also www.endress.com)

**Seal**

- FKM
- EPDM (FDA 21 CFR 177.2600)
- HNBR (FDA 21 CFR 177.2600)
- FFKM Perlast G75LT
- FFKM Chemraz 505
- FFKM Kalrez 6375

**Process connections**

See the specific process connection.

**Accessories**

For technical data (e.g. materials, dimensions or order numbers), see the accessory document SDO1553P.

**Materials not in contact with process****Single compartment housing and cover**

Polyester powder coating on aluminum as per EN1706 AC43400 (reduced copper content ≤0.1 % to prevent corrosion)

**Dual compartment housing and cover**

- Polyester powder coating on aluminum as per EN1706 AC43400 (reduced copper content ≤0.1 % to prevent corrosion)
- Stainless steel (ASTM A351 : CF3M (cast equivalent to material AISI 316L) / DIN EN 10213 : 1.4409)

**Separate housing**

- Mounting bracket
  - Bracket: AISI 316L (1.4404)
  - Screw and nuts: A4-70
  - Half-shells: AISI 316L (1.4404)
- Seal for cable from separate housing: EPDM
- Gland for cable of separate housing: AISI 316L (1.4404)
- PE cable for separate housing: abrasion-proof cable with strain-relief Dynema members; shielded using aluminum-coated foil; insulated with polyethylene (PE-LD), black; copper wires, twisted, UV-resistant
- FEP cable for separate housing: abrasion-proof cable; shielded using galvanized steel wire netting; insulated with fluorinated ethylene propylene (FEP), black; copper cores, twisted, UV-resistant
- Process connection adapter for separate housing: AISI 316L (1.4404)

**Aluminum housing nameplate**

- Adhesive polyester label
- Versions that can be ordered for use at reduced ambient temperatures: metal wired-on tag plate made of 316L (1.4404)

**Nameplate of stainless steel housing**

- Metal nameplate made of 316L (1.4404)  
Nameplate fasteners (rivets) made of 316Ti (1.4571)
- Versions that can be ordered for use at reduced ambient temperatures: metal wired-on tag plate made of 316L (1.4404)

**Cable entries**

- M20 gland:  
Plastic, brass nickel plated or 316L (depends on version ordered)  
Dummy plug made of plastic, aluminum or 316L (depends on version ordered)
- Thread M20:  
Dummy plug made of aluminum or 316L (depends on version ordered)
- Thread G1/2:  
Adapter made of aluminum or 316L (depends on version ordered)  
If the G1/2 thread is selected, the device is delivered with an M20 thread as standard and a G1/2 adapter is included with the delivery, along with the corresponding documentation
- Thread NPT1/2:  
Dummy plug made of aluminum or 316L (depends on version ordered)
- Plug M12:  
CuZn nickel-plated or 316L (depends on version ordered)  
Dummy plug made of aluminum or 316L (depends on version ordered)
- Plug HAN7D:  
Aluminum, die-cast zinc, steel  
Dummy plug made of aluminum or 316L (depends on version ordered)

**Connecting parts**

- Connection between housing and process connection: AISI 316L (1.4404)
- Measuring cell body: AISI 316L (1.4404)

**Accessories**

For technical data (e.g. materials, dimensions or order numbers), see the accessory document SD01553P.

---

## Operability

---

### Operating concept

#### Operator-oriented menu structure for user-specific tasks

- User navigation
- Diagnostics
- Application
- System

#### Fast and safe commissioning

- Interactive wizard with graphical user interface for guided commissioning in FieldCare, DeviceCare or DTM, AMS and PDM-based third-party tools or SmartBlue
- Menu guidance with short explanations of the individual parameter functions
- Standardized operation at the device and in the operating tools
- PROFINET with Ethernet-APL: access to the device via Web server

#### Integrated HistoROM data memory

- Adoption of data configuration when electronics modules are replaced
- Up to 100 event messages recorded in the device

#### Efficient diagnostic behavior increases measurement availability

- Remedial measures are integrated in plain text
- Diverse simulation options

#### Bluetooth module (optionally integrated in local display)

- Quick and easy setup with SmartBlue app or PC with DeviceCare, version 1.07.00 and higher, or FieldXpert SMT70
  - No additional tools or adapters required
  - Encrypted single point-to-point data transmission (tested by Fraunhofer Institute) and password-protected communication via *Bluetooth*<sup>®</sup> wireless technology
- 

### Languages

#### Operating languages

- English (English is set at the factory if no other language is ordered)
- Deutsch
- Français
- Español
- Italiano
- Nederlands
- Portuguesa
- Polski
- русский язык (Russian)
- Türkçe
- 中文 (Chinese)
- 日本語 (Japanese)
- 한국어 (Korean)
- Bahasa Indonesia
- tiếng Việt (Vietnamese)
- čeština (Czech)
- Svenska

## Local operation

## Operating keys and DIP switches on the electronic insert

## HART

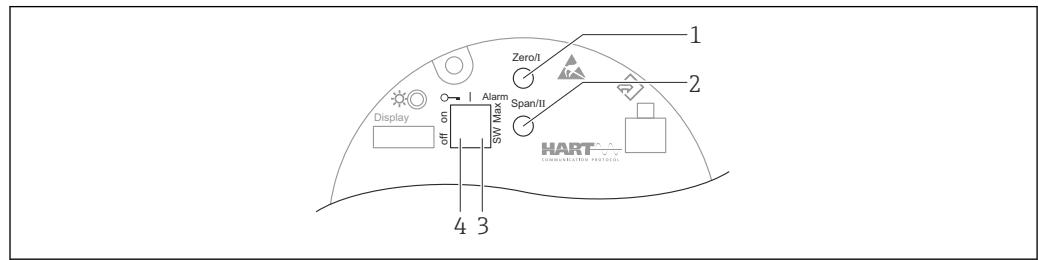

A0039285

- 1 Operating key for lower range value (Zero)
- 2 Operating key for upper range value (Span)
- 3 DIP switch for alarm current
- 4 DIP switch for locking and unlocking the device

**i** The setting of the DIP switches has priority over the settings made via other operation methods (e.g. FieldCare/DeviceCare).

## PROFINET with Ethernet-APL

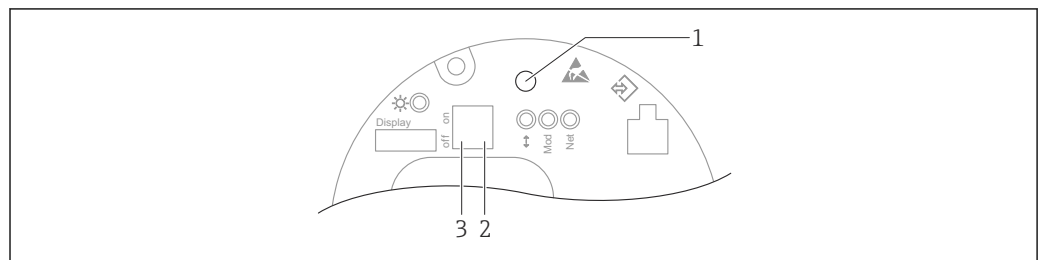

A0046061

- 1 Operating key for position adjustment (zero point correction) and device reset
- 2 DIP switch for setting the service IP address
- 3 DIP switch for locking and unlocking the device

**i** The setting of the DIP switches has priority over the settings made via other operation methods (e.g. FieldCare/DeviceCare).

## Local display

## Device display (optional)

## Functions:

- Display of measured values and fault and notice messages
- Background lighting, which switches from green to red in the event of an error
- The device display can be removed for easier operation

**i** The device displays are available with the additional option of Bluetooth® wireless technology.



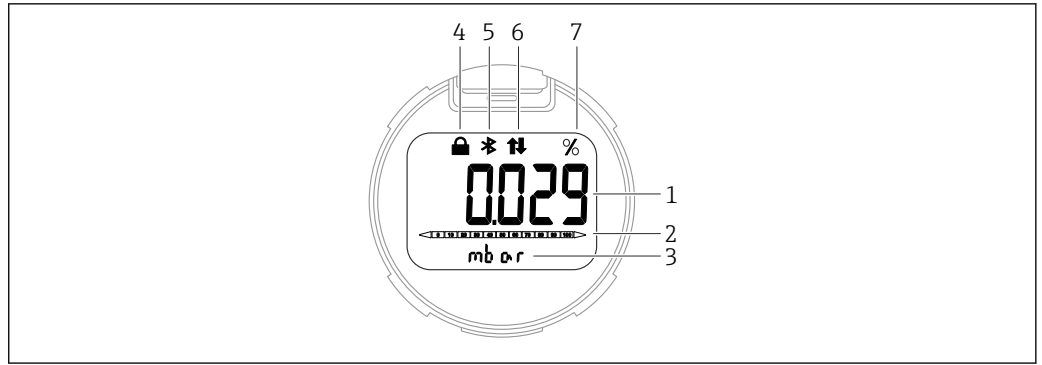

A0043599

**6** Segment display

- 1 Measured value (up to 5 digits)
- 2 Bar graph proportional to the current output (not for PROFINET with Ethernet-APL)
- 3 Unit of measured value
- 4 Locked (symbol appears when the device is locked)
- 5 Bluetooth (symbol flashes if Bluetooth connection is active) (only HART and PROFINET with Ethernet-APL)
- 6 HART communication (symbol is displayed if HART communication is active) , or communication via PROFINET is active (only HART and PROFINET with Ethernet-APL)
- 7 Measured value output in %

The following graphics are examples. The display depends on the display settings.

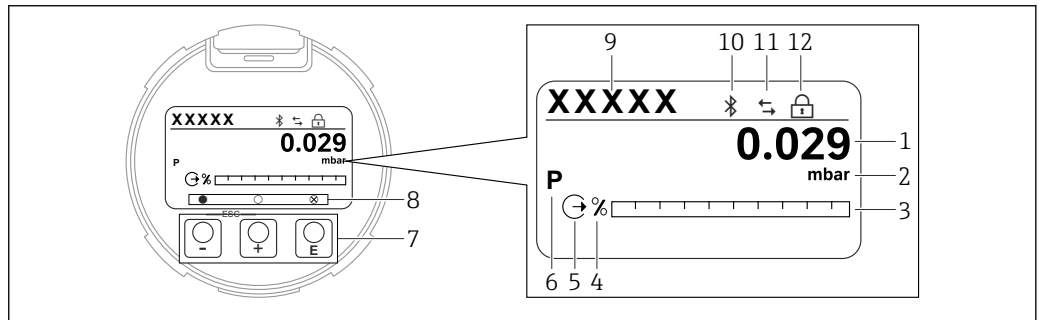

A0047142

**7** Graphic display with optical operating keys.

- 1 Measured value (up to 12 digits)
- 2 Unit of measured value
- 3 Bar graph proportional to the current output (not for PROFINET with Ethernet-APL)
- 4 Bar graph unit
- 5 Symbol for current output
- 6 Symbol for displayed measured value (e.g. p = pressure)
- 7 Optical operating keys
- 8 Symbols for key feedback. Different display symbols are possible: circle (not filled in) = key pressed briefly; circle (filled in) = key pressed for longer; circle (with X) = no operation possible due to Bluetooth connection
- 9 Device Tag
- 10 Bluetooth (symbol flashes if Bluetooth connection is active)
- 11 HART communication (symbol is displayed if HART communication is active) , or communication via PROFINET is active
- 12 Locked (symbol appears when the device is locked)

Remote operation

Via HART protocol or Bluetooth

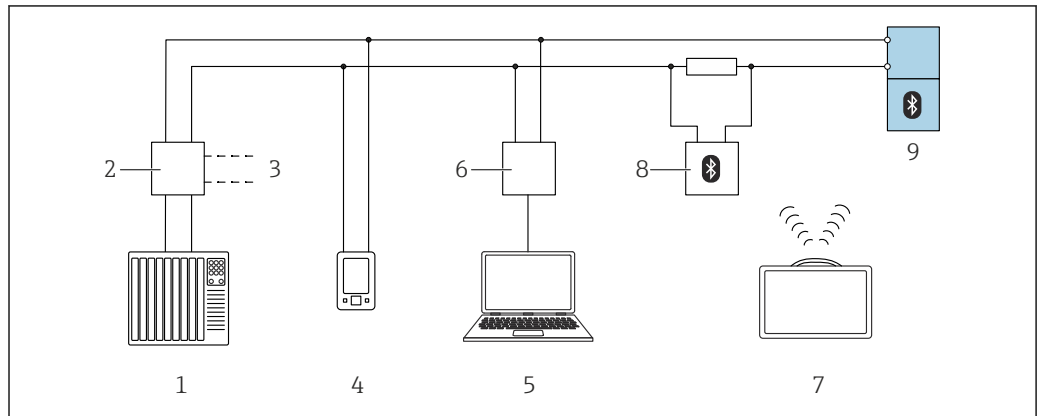

A0044334

8 Options for remote operation via HART protocol

- 1 PLC (programmable logic controller)
- 2 Transmitter power supply unit, e.g. RN221N (with communication resistor)
- 3 Connection for Commubox FXA195 and AMS Trex™ device communicator
- 4 AMS Trex™ device communicator
- 5 Computer with operating tool (e.g. DeviceCare/FieldCare, AMS Device View, SIMATIC PDM)
- 6 Commubox FXA195 (USB)
- 7 Field Xpert SMT70
- 8 Bluetooth modem with connecting cable (e.g. VIATOR)
- 9 Transmitter

Via PROFINET with Ethernet-APL network

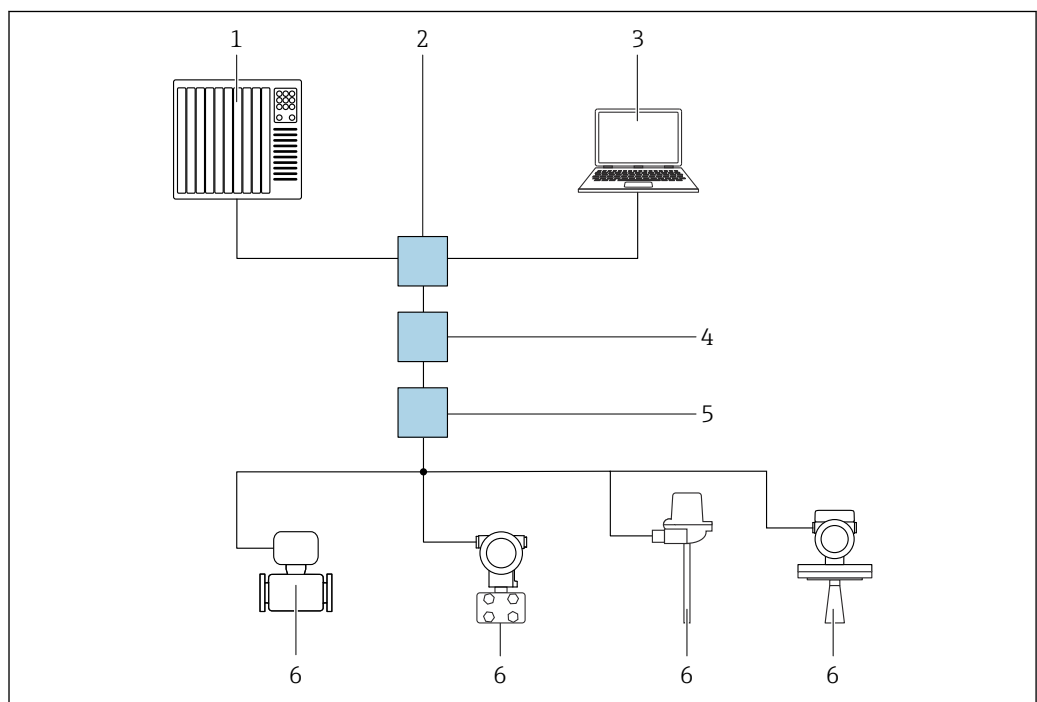

A0046097

9 Options for remote operation via PROFINET with Ethernet-APL network: star topology

- 1 Automation system, e.g. Simatic S7 (Siemens)
- 2 Ethernet switch
- 3 Computer with web browser (e.g. Microsoft Edge) for accessing the integrated device web server or computer with operating tool (e.g. FieldCare, DeviceCare, SIMATIC PDM) with iDTM Profinet Communication
- 4 APL field switch (optional)
- 5 APL field switch
- 6 APL field device

Call up the website via the computer in the network. The IP address of the device must be known.

The IP address can be assigned to the device in a variety of ways:

- Dynamic Configuration Protocol (DCP), factory setting  
The automation system (e.g. Siemens S7) automatically assigns the IP address to the device
- Software addressing  
The IP address is entered via the IP address parameter
- DIP switch for service  
The device then has the fixed IP address 192.168.1.212  
The IP address can now be used to establish the connection to the network

The default setting is that the device uses the Dynamic Configuration Protocol (DCP). The automation system (e.g. Siemens S7) automatically assigns the IP of the device.

**Via Web browser (for devices with PROFINET)**

*Function scope*

Thanks to the integrated Web server the device can be operated and configured via a Web browser. The structure of the operating menu is the same as for the local display. In addition to the measured values, device status information is also displayed and allows users to monitor the status of the device. Furthermore the device data can be managed and the network parameters can be configured.

**Via service interface (CDI)**

With the Commubox FXA291, a CDI connection is established with the device interface and a Windows PC/notebook with a USB port.

**Operation via Bluetooth® wireless technology (optional)**

Prerequisite

- Device with Bluetooth display
- Smartphone or tablet with Endress+Hauser SmartBlue app or PC with DeviceCare from version 1.07.00 or FieldXpert SMT70

The connection has a range of up to 25 m (82 ft). The range can vary depending on environmental conditions such as attachments, walls or ceilings.



The operating keys on the display are locked as soon as the device is connected via Bluetooth.

---

**System integration**

**HART**

Version 7

**PROFINET with Ethernet-APL**

PROFINET Profile 4.02

---

**Supported operating tools**

Smartphone or tablet with Endress+Hauser SmartBlue (app), DeviceCare, version 1.07.00 and higher, FieldCare, DTM, AMS and PDM.

PC with Web server via fieldbus protocol.

---

**HistoROM**

When replacing the electronic insert, the stored data is transferred by reconnecting the HistoROM. The device does not work without HistoROM.

The device serial number is saved in the HistoROM. The electronics serial number is saved in the electronics.

## Certificates and approvals

Current certificates and approvals that are available for the product can be selected via the Product Configurator at [www.endress.com](http://www.endress.com):

1. Select the product using the filters and search field.
2. Open the product page.
3. Select **Configuration**.

---

**CE mark** The device meets the legal requirements of the relevant EC directives. Endress+Hauser confirms that the device has been successfully tested by applying the CE mark.

---

**RCM-Tick marking** The supplied product or measuring system meets the ACMA (Australian Communications and Media Authority) requirements for network integrity, interoperability, performance characteristics as well as health and safety regulations. Here, especially the regulatory arrangements for electromagnetic compatibility are met. The products bear the RCM-Tick marking on the nameplate.



A0029561

---

**Ex approvals**

- ATEX
- CSA
- NEPSI
- UKCA
- INMETRO
- KC
- EAC (in preparation)
- JPN
- Also combinations of different approvals

All the data related to explosion protection is provided in separate Ex documentation which is also available upon request. The Ex documentation is supplied as standard with all devices approved for use in explosion hazardous areas.

Additional approvals in preparation.

### Explosion-protected smartphones and tablets

If used in hazardous areas, mobile terminals with an Ex approval must be used.

---

**Sanitary compatibility** The following applies for the ceramic membrane:

The US Food & Drug Administration (FDA) has no objections to the use of ceramics made from aluminum oxide as a surface material in contact with foodstuffs. This declaration is based on the FDA certificates of our ceramic suppliers.

---

**EAC conformity** The device meets the legal requirements of the applicable EAC Directives. These are listed in the corresponding EAC Declaration of Conformity along with the standards applied.

Endress+Hauser confirms successful testing of the device by affixing to it the EAC mark.

---

**Drinking water approval**

- NSF/ANSI 61 drinking water approval
- KTW drinking water approval W 270

---

**Overfill protection (in preparation)** The device is tested in accordance with the approval guidelines for overfill protection units (ZG-ÜS:2012-07) as overfill protection as per Section 63 of the German Water Resources Act (WHG).

---

**Functional safety SIL/ IEC 61508 Declaration of Conformity (optional)** The devices with a 4-20 mA output signal have been developed according to the IEC 61508 standard. These devices can be used to monitor the process level and pressure up to SIL 3. For a detailed description of the safety functions, settings and functional safety data, see the "Functional Safety Manual".

<b>Marine approval</b>	<ul style="list-style-type: none"> <li>■ ABS (American Bureau of Shipping)</li> <li>■ LR (Lloyd's Register)</li> <li>■ BV (Bureau Veritas)</li> <li>■ DNV GL (Det Norske Veritas / German Lloyd)</li> </ul>
<b>Radio approval</b>	Displays with Bluetooth LE have radio licenses according to CE and FCC. The relevant certification information and labels are provided on display.
<b>CRN approval</b>	A CRN approval (Canadian Registration Number) is available for some device versions. These devices are fitted with a separate plate bearing the registration number CRN 0F23358.5C. In order to obtain a CRN-approved device, a CRN-approved process connection must be ordered along with the option "CRN" in the order code for "Additional approvals".
<b>Test reports</b>	<p><b>Test, certificate, declarations</b></p> <ul style="list-style-type: none"> <li>■ Inspection certificate 3.1, EN10204 (material certificate, wetted metallic parts)</li> <li>■ NACE MR0175 / ISO 15156 (wetted metallic parts), declaration</li> <li>■ NACE MR0103 / ISO 17945 (wetted metallic parts), declaration</li> <li>■ AD 2000 (wetted metallic parts), declaration, excluding membrane</li> <li>■ Pressure test, internal procedure, test report</li> <li>■ Helium leak test, internal procedure, test report</li> <li>■ PMI test, internal procedure (wetted metallic parts), test report</li> </ul> <p>Test reports, declarations and inspection certificates are provided electronically in the Device Viewer: enter the serial number of the nameplate (<a href="http://www.endress.com/deviceviewer">www.endress.com/deviceviewer</a>).</p> <p>Applicable for the order codes "Calibration" and "Test, certificate".</p> <p><b>Product documentation on paper</b></p> <p>Test reports, declarations and inspection certificates in hard copy can optionally be ordered with the order option "Product documentation on paper". These documents are supplied with the ordered product.</p> <p><b>Calibration</b></p> <p>5-point calibration certificate 10-point calibration certificate, traceable to ISO/IEC 17025</p> <p><b>Manufacturer declarations</b></p> <p>A variety of manufacturer declarations can be downloaded from the Endress+Hauser website. Other manufacturer declarations can be ordered through the Endress+Hauser sales office.</p> <p><i>Downloading the Declaration of Conformity</i> <a href="http://www.endress.com">www.endress.com</a> → Download</p>
<b>Pressure Equipment Directive 2014/68/EU (PED)</b>	<p><b>Pressure equipment with allowable pressure ≤ 200 bar (2 900 psi)</b></p> <p>Pressure equipment (maximum working pressure PS ≤ 200 bar (2 900 psi)) can be classified as pressure accessories according to the Pressure Equipment Directive 2014/68/EU. If the maximum working pressure is ≤ 200 bar (2 900 psi) and the pressurized volume of the pressure equipment is ≤ 0.1 l, the pressure equipment is subject to the Pressure Equipment Directive (see Pressure Equipment Directive 2014/68/EU, Article 4, point 3). The Pressure Equipment Directive only requires that the pressure equipment shall be designed and manufactured in accordance with the "sound engineering practice of a Member State".</p> <p><i>Reasons:</i></p> <ul style="list-style-type: none"> <li>■ Pressure Equipment Directive (PED) 2014/68/EU Article 4, point 3</li> <li>■ Pressure equipment directive 2014/68/EU, Commission's Working Group "Pressure", Guideline A-05 + A-06</li> </ul> <p><i>Note:</i></p> <p>A partial examination shall be performed for pressure instruments that are part of a safety instrumented system for the protection of a pipe or vessel from exceeding allowable limits (safety accessory in accordance with Pressure Equipment Directive 2014/68/EU, Article 2, point 4).</p>

**Pressure equipment with allowable pressure > 200 bar (2 900 psi)**

Pressure equipment designated for application in every process fluid having a pressurized volume of <0.1 l and a max. allowable pressure PS > 200 bar (2 900 psi) must satisfy the essential safety requirements set out in Annex I of the Pressure Equipment Directive 2014/68/EU. According to Article 13 pressure equipment shall be classified by category in accordance with Annex II. Taking into account the low volume specified above, the pressure instruments can be categorized as category I pressure equipment. These devices must then bear the CE marking.

*Reasons:*

- Pressure Equipment Directive 2014/68/EU, Article 13, Annex II
- Pressure equipment directive 2014/68/EU, Commission's Working Group "Pressure", Guideline A-05

*Note:*

A partial examination shall be performed for pressure instruments that are part of a safety instrumented system for the protection of a pipe or vessel from exceeding allowable limits (safety accessory in accordance with Pressure Equipment Directive 2014/68/EU, Article 2, point 4).

<b>Oxygen application</b>	Verified cleaned, suitable for O2 service (wetted parts)
<b>PWIS-free applications</b>	Special cleaning of the transmitter to remove paint-wetting impairment substances, for use in paint shops, for instance.
<b>China RoHS symbol</b>	The device is visibly identified according to SJ/T 11363-2006 (China-RoHS).
<b>RoHS</b>	The measuring system complies with the substance restrictions of the Restriction on Hazardous Substances Directive 2011/65/EU (RoHS 2).
<b>Certification PROFINET with Ethernet-APL</b>	<p><b>PROFINET with Ethernet-APL interface</b></p> <p>The device is certified and registered by the PNO (PROFIBUS Nutzerorganisation e.V. / PROFIBUS User Organization). The measuring system meets all the requirements of the following specifications:</p> <ul style="list-style-type: none"> <li>▪ Certified according to: <ul style="list-style-type: none"> <li>▪ Test specification for PROFINET devices</li> <li>▪ PROFINET Security Level – Netload Class</li> </ul> </li> <li>▪ The device can also be operated with certified devices of other manufacturers (interoperability)</li> </ul>
<b>Additional certification</b>	<p><b>Classification of process sealing between electrical systems and (flammable or combustible) process liquids according to UL 122701 (previously ANSI/ISA 12.27.01)</b></p> <p>Endress+Hauser devices are designed according to UL 122701 (previously ANSI/ISA 12.27.01) and allow the user to waive the use of - and save the cost of installing - external secondary process seals in the conduit as required by the process sealing sections of ANSI/NFPA 70 (NEC) and CSA 22.1 (CEC). These devices comply with the North-American installation practice and provide a very safe and cost-saving installation for pressurized applications with hazardous media. The devices are assigned to "single seal" as follows:</p> <p>CSA C/US IS, XP, NI: 40 bar (600 psi)</p> <p>Further information can be found in the control drawings of the relevant devices.</p> <p><b>Metrological accreditation</b></p> <p>With the order option "China", the device is supplied with a Chinese nameplate in accordance with the Chinese Quality Law.</p>

## Ordering information

### Ordering information

Detailed ordering information is available from the nearest sales organization [www.addresses.endress.com](http://www.addresses.endress.com) or in the Product Configurator under [www.endress.com](http://www.endress.com):

1. Select the product using the filters and search field.
2. Open the product page.

The **Configuration** button opens the Product Configurator.



#### Product Configurator - the tool for individual product configuration

- Up-to-the-minute configuration data
- Depending on the device: direct input of information specific to the measuring point, such as the measuring range or operating language
- Automatic verification of exclusion criteria
- Automatic creation of the order code and its breakdown in PDF or Excel output format
- Ability to order directly in the Endress+Hauser Online Shop

### Scope of delivery

The scope of delivery comprises:

- Device
- Optional accessories

Accompanying documentation:

- Brief Operating Instructions
- Final inspection report
- Additional Safety Instructions for devices with approvals (e.g. ATEX, IECEx, NEPSI, etc.)
- Optional: factory calibration form, test certificates



The Operating Instructions are available on the Internet at:

[www.endress.com](http://www.endress.com) → Download

### Measuring point (tag)

- Order code: marking
- Option: Z1, tagging (TAG), see additional specification
- Location of tag identifier: to be selected in the additional specifications
  - Tag plate, stainless steel
  - Self-adhesive paper label
  - Supplied plate
  - RFID TAG
  - RFID TAG + tag plate stainless steel
  - RFID TAG + self-adhesive paper label
  - RFID TAG + supplied label/plate
- Definition of tag name: to be defined in the additional specifications  
3 lines, each containing up to maximum 18 characters  
The specified tag name appears on the selected label and/or the RFID TAG
- Identification on electronic nameplate (ENP): 32 digits

### Test reports, declarations and inspection certificates

All test reports, declarations and inspection certificates are provided electronically in the *Device Viewer*:

Enter the serial number from the nameplate ([www.endress.com/deviceviewer](http://www.endress.com/deviceviewer))



#### Product documentation on paper

Test reports, declarations and inspection certificates in hard copy can optionally be ordered with feature 570 "Service", Version I7 "Product documentation on paper". The documents are then provided with the device upon delivery.

---

## Application packages

---

### Heartbeat Technology

#### Availability

Available in all device versions.

Heartbeat Verification + Monitoring, optional.

#### Heartbeat Diagnostics

- Continuous self-monitoring of the device
- Diagnostic messages output to
  - the local display
  - an asset management system (e.g. FieldCare or DeviceCare)
  - an automation system (e.g. PLC)
  - Web server

#### Heartbeat Verification

- Device monitoring in installed state without interrupting the process, including report
- Clear measuring point assessment (pass/fail) with high total test coverage within the framework of the manufacturer's specifications
- Can be used to document normative requirements

#### Heartbeat Monitoring

- Statistical Sensor Diagnostics: statistical analysis and evaluation of the pressure signal, including signal noise, to detect process anomalies (e.g. blocked impulse lines)
- Loop Diagnostics: detection of elevated measuring circuit resistance values or declining power supply
- Process window: user-definable pressure and temperature limits to detect dynamic pressure surges or faulty trace heating systems or insulation
- Continuously supplies additional monitoring data to an external condition monitoring system for the purpose of predictive maintenance or process monitoring

#### Detailed description

See Special Documentation for SD Heartbeat Technology.

---

### High-temperature version

High-temperature version 150 °C (302 °F) process, optionally available.



---

## Accessories

---

### Device-specific accessories

#### Mechanical accessories

- Mounting bracket for housing
- Mounting bracket for block & bleed valves
- Block&Bleed valves:
  - Block&Bleed valves can be ordered as **enclosed** accessories (seal for mounting is enclosed)
  - Block&Bleed valves can be ordered as **mounted** accessories (mounted manifolds are supplied with a documented leak test)
  - Certificates (e.g. 3.1 material certificate and NACE) and tests (e.g. PMI and pressure test) that are ordered with the device apply for the transmitter and the manifold
  - During the operating life of the valves, it may be necessary to re-tighten the pack
- Water pocket pipes (PZW)
- Flushing rings
- Weather protection covers



For technical data (e.g. materials, dimensions or order numbers), see the accessory document SD01553P.

#### Plug connectors

- Plug connector M12 90 deg, IP67 5m cable, union nut, Cu Sn/Ni
- Plug connector M12, IP67 union nut, Cu Sn/Ni
- Plug connector M12, 90 deg IP67 union nut, Cu Sn/Ni



The IP protection classes are only maintained if the dummy cap is used or the cable is connected.

#### Weld-in accessory



For details, refer to TI00426F/00/EN "Weld-in adapters, process adapters and flanges".

---

### Device Viewer

All the spare parts for the device, along with the order code, are listed in the *Device Viewer* ([www.endress.com/deviceviewer](http://www.endress.com/deviceviewer)).

## Documentation

-  For an overview of the scope of the associated Technical Documentation, refer to the following:
- *Device Viewer* ([www.endress.com/deviceviewer](http://www.endress.com/deviceviewer)): Enter the serial number from the nameplate
  - *Endress+Hauser Operations app*: Enter serial number from nameplate or scan matrix code on nameplate.

---

### Standard documentation

- **Technical Information: planning guide**  
The document contains all the technical data on the device and provides an overview of the accessories and other products that can be ordered for the device
- **Brief Operating Instructions: takes you quickly to the 1st measured value**  
The Brief Operating Instructions contain all the essential information from incoming acceptance to initial commissioning
- **Operating Instructions: reference manual**  
The Operating Instructions contain all the information that is required in the various phases of the life cycle of the device: from product identification, incoming acceptance and storage, to mounting, connection, operation and commissioning through to troubleshooting, maintenance and disposal

---

### Supplementary device-dependent documentation

Additional documents are supplied depending on the device version ordered: Always comply strictly with the instructions in the supplementary documentation. The supplementary documentation is an integral part of the device documentation.

---

### Field of Activities

-  Document FA00004P  
Pressure measurement, powerful devices for process pressure, differential pressure, level and flow

---

### Special Documentation

-  Document SD01553P  
Mechanical accessories for pressure equipment  
The documentation provides an overview of available manifolds, oval flange adapters, pressure gauge valves, shutoff valves, water pocket pipes, condensate pots, cable shortening kits, test adapters, flushing rings, Block&Bleed valves and protective roofs.

## Registered trademarks

### HART®

Registered trademark of the FieldComm Group, Austin, Texas, USA

### PROFINET®

Registered trademark of the PROFIBUS User Organization, Karlsruhe, Germany

### Bluetooth®

The Bluetooth® wordmark and logos are registered trademarks of Bluetooth SIG, Inc. and any use of these trademarks by Endress+Hauser is licensed. Other trademarks and trade names are those of their respective owners.

### KALREZ®

Registered trademark of DuPont Performance Elastomers L.L.C., Wilmington, USA

---



71605787

[www.addresses.endress.com](http://www.addresses.endress.com)

---