

PW Series (PPG) General Purpose Magnetic Drive Pumps

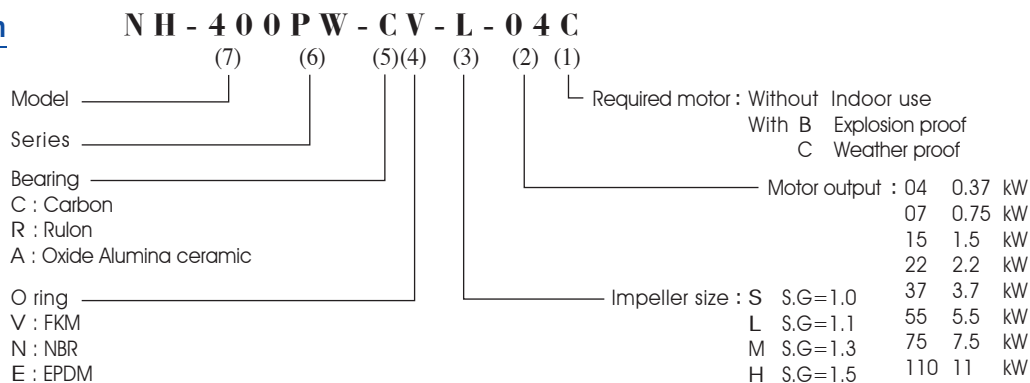

- PPG wetted-end material.
- 16 models with flow rates up to 1400 lit/min and discharge head of 44m.
- Able to handle many types of chemical and temperature up to 70°C.
- Adaptable to IEC Standard motor, 0.37 to 11 kW.
- Available in flange connections.

Type indication



Specification table

Type	Flange size		Pump performance at specified point (M at L/min)			Applicable Motor output (kW)	Net weight w/t motor (Kg)
	Outlet(mm)	Inlet(mm)	Specific Gravity	50Hz	60Hz		
NH-350PW	25	25	1.0	11.0 - 80	13.0 - 80	0.37	16
			1.3	12.0 - 60	14.0 - 40		
			1.5	11.0 - 40	11.0 - 50		
NH-351PW	25	25	1.0	13.7 - 100	17.3 - 100	0.75	30
			1.3	14.5 - 80	17.0 - 80		
			1.5	12.4 - 80	14.5 - 70		
NH-352PW	32	32	1.0	23.0 - 180	29.0 - 140	1.5	43
			1.3	22.0 - 100	26.0 - 100		
			1.5	21.0 - 100	25.0 - 100		
NH-353PW	32	32	1.0	23.0 - 180	32.0 - 150	2.2	51
			1.3	24.0 - 150	31.0 - 120		
			1.5	22.0 - 150	29.0 - 120		
NH-400PW	40	40	1.1	8.3 - 165	6.7 - 160	0.37	21
			1.3	7.0 - 155	7.0 - 155		
			1.5	6.1 - 130	5.9 - 130		
NH-401PW	40	40	1.1	12.0 - 240	11.5 - 250	0.75	30
			1.3	9.8 - 185	9.2 - 200		
			1.5	9.1 - 165	7.5 - 200		
NH-402PW	40	50	1.1	14.0 - 320	14.0 - 300	1.5	45
			1.3	14.0 - 280	13.9 - 265		
			1.5	12.0 - 280	14.5 - 220		
NH-403PW	40	50	1.1	20.0 - 310	19.0 - 280	2.2	47
			1.3	16.0 - 340	17.0 - 280		
			1.5	15.5 - 340	14.7 - 340		
NH-405PW	40	50	1.1	23.0 - 390	24.0 - 420	3.7	70
			1.3	21.1 - 400	24.0 - 390		
			1.5	19.0 - 390	20.0 - 390		
NH-505PW(L)	50	65	1.0	22.0 - 500	22.0 - 500	3.7	72
			1.1	20.0 - 500	20.0 - 500		
			1.3	19.0 - 500	19.0 - 500		
			1.5	16.0 - 500	16.0 - 500		
NH-505PW(H)	50	65	1.0	25.0 - 350	28.0 - 350	3.7	72
			1.1	25.0 - 350	26.0 - 350		
			1.3	22.0 - 350	24.0 - 350		
			1.5	20.0 - 350	19.7 - 350		
NH-507PW	50	65	1.0	24.0 - 600	27.0 - 600	5.5	99
			1.1	22.0 - 600	24.0 - 600		
			1.3	19.0 - 600	21.0 - 600		
			1.5	19.0 - 600	19.0 - 600		
NH-655PW	65	80	1.1	15.0 - 700	15.5 - 600	3.7	110
			1.3	12.0 - 650	-		
			1.5	10.2 - 570	-		
NH-657PW	65	80	1.1	17.5 - 800	18.0 - 750	5.5	120
			1.3	17.6 - 630	16.5 - 630		
			1.5	15.3 - 620	13.3 - 760		
NH-6510PW	65	80	1.1	23.4 - 780	23.4 - 800	7.5	130
			1.3	22.7 - 640	19.6 - 770		
			1.5	17.5 - 800	18.1 - 670		
NH-6515PW	65	80	1.1	25.5 - 1040	29.5 - 1030	11	140
			1.3	25.5 - 1040	31.5 - 650		
			1.5	25.2 - 880	24.6 - 850		

PW Series

Parts List

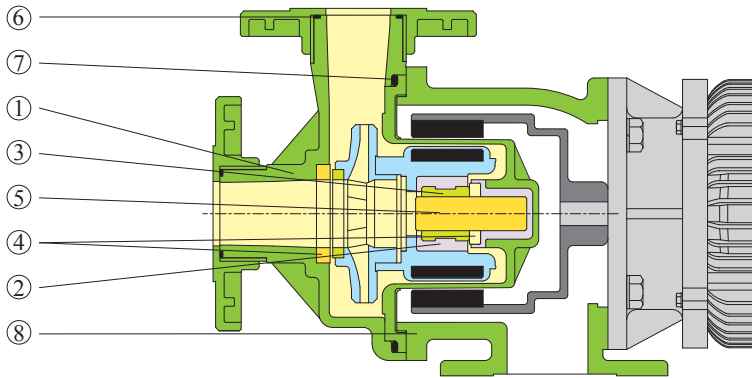

Part name	PW Series				
	CV	RV	AV	CN	AN
1. Casing	PPG				
2. Holder	ETFE				
3. Bearing	H.D. Carbon	Rulon	Ceramic	H.D. Carbon	Ceramic
4. Thrust pad	Ceramic				
5. Spindle	Ceramic				
6. O ring	FKM		NBR		
7. O ring	FKM		NBR		
8. Bracket	Grey cast iron				

PW series performance curve

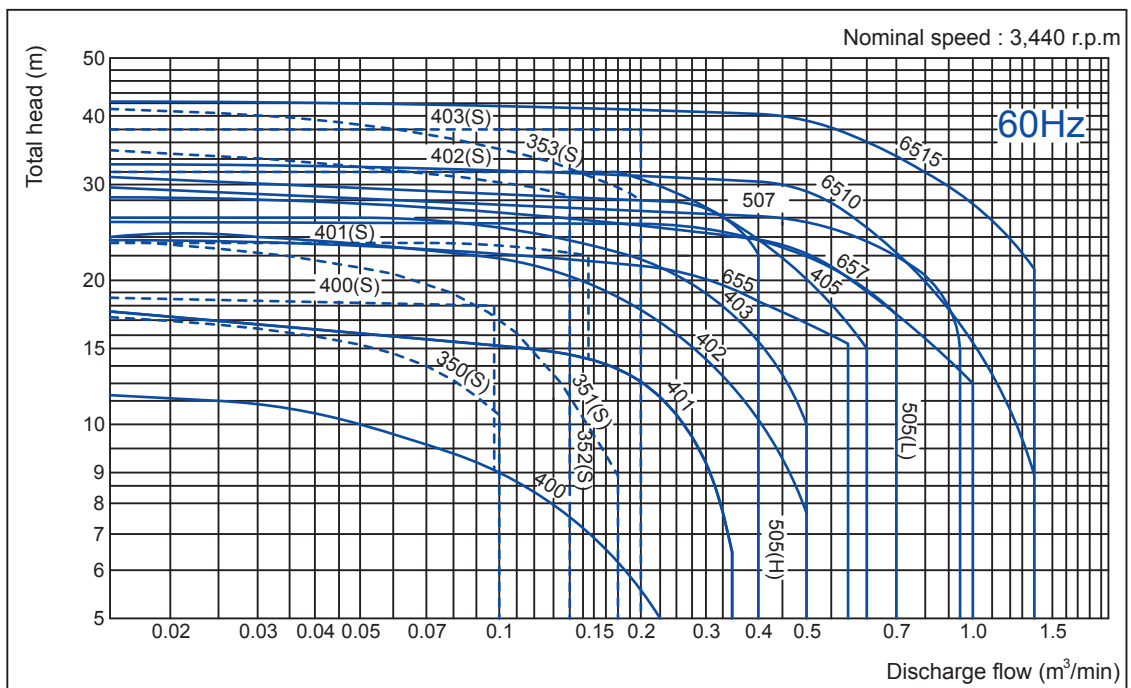
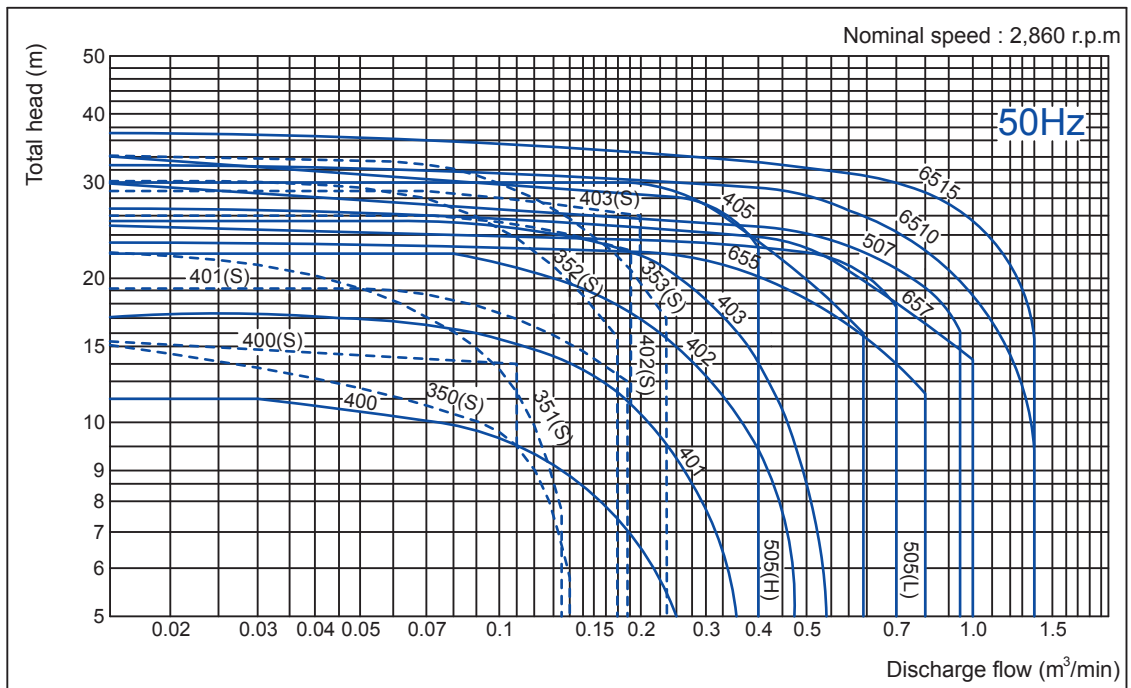

PW/PW-F Series

Installation dimension

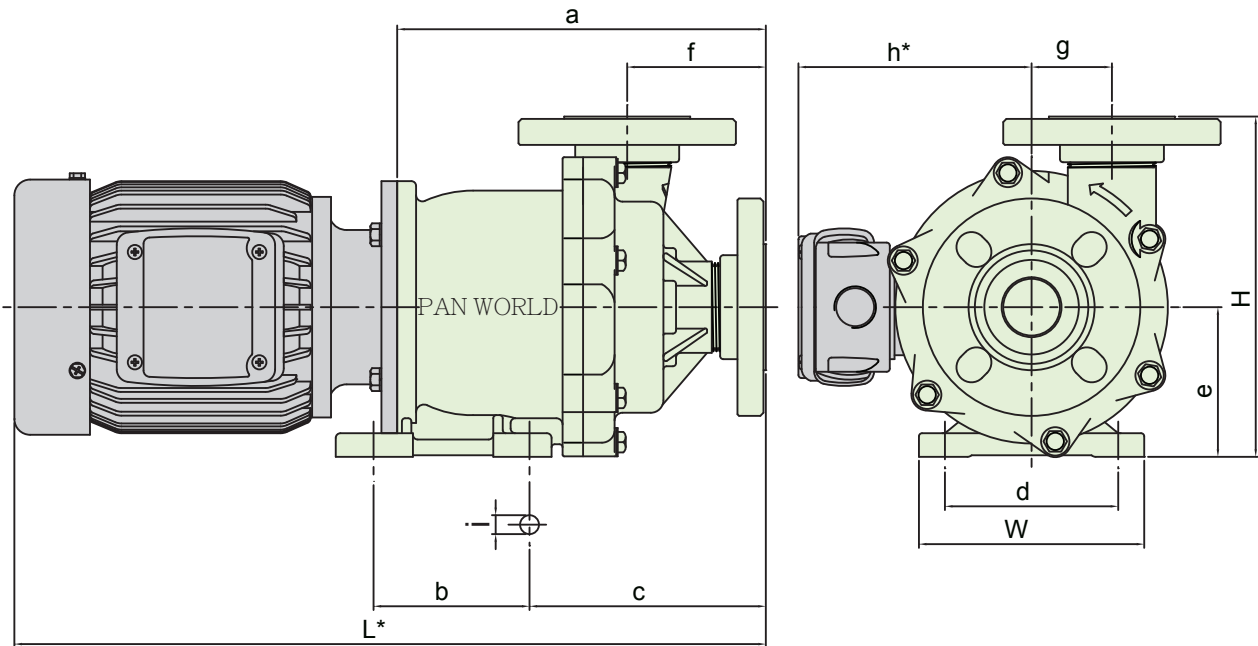

Dimensions in mm

MODEL	W	H	L*	a	b	c	d	e	f	g	h	i
350 PW / PW-F	157	257	472	232.5	130	161	130	115	88	77.5	138.5	12
351 PW / PW-F	160	257	470	240	130	170	130	115	88	77.5	145	12
352 PW / PW-F	160	242	505.5	222.5	132	155	130	120	78	57	149	12
353 PW / PW-F	160	242	505.5	222.5	132	155	130	120	78	57	149	12
400 PW / PW-F	140	216	473	233	98	150	110	95	87	51	151	12
401 PW / PW-F	160	254	488	256	130	184	130	115	102.5	57.5	160	12
402 PW / PW-F	260	255	620	305	200	158	208	115	89	65	176	14
403 PW / PW-F	260	255	620	305	200	158	208	115	89	65	176	14
405 PW / PW-F	260	270	689	326	200	158	208	130	89	65	208	14
505 PW / PW-F	260	319	650.5	287.5	300	123.2	220	162	89.5	60	208	14
507 PW / PW-F	260	319	676.5	311.5	300	123.2	220	162	89.5	60	252	14
655 PW / PW-F	260	360	723	360	270	240	210	175	118	85	208	14
657 PW / PW-F	260	360	745	380	270	240	210	175	118	85	252	14
6510 PW / PW-F	260	360	745	380	270	240	210	175	118	85	252	14
6515 PW / PW-F	350	385	918.5	408.5	270	240	300	200	118	85	285	14

Remarks :

1. This size in the table is shown with JIS motor.
2. Over all size & construction may be changed without notice.
3. * Depending on type of motor used.