

DS Series

Compact diaphragm dosing pump

- 호스타입 소형 다이어프램 펌프



PVC - 15W Motor

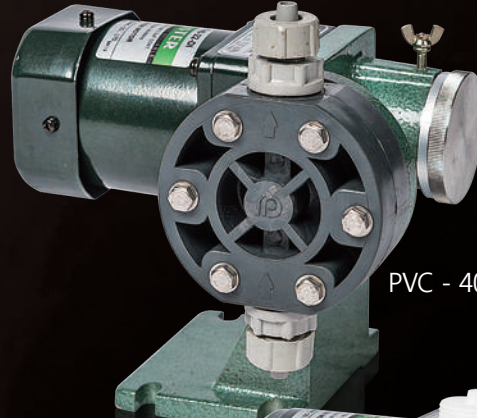

PVC - 40W Motor

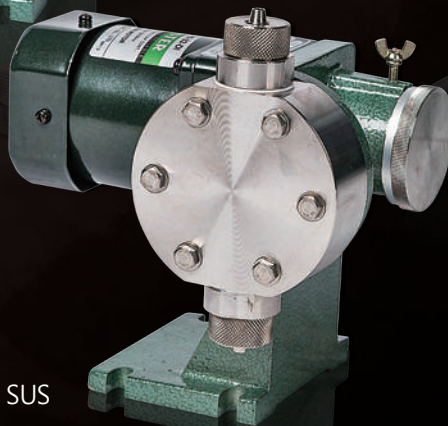

SUS

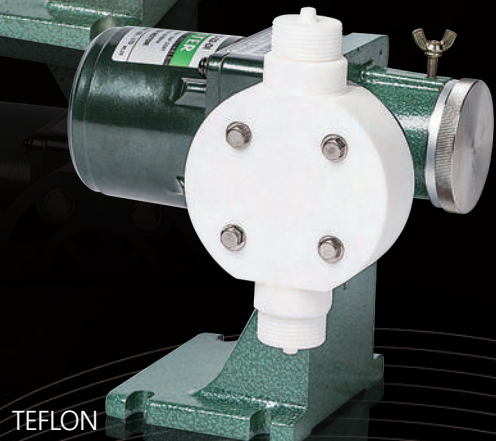

TEFLON

Capacity - Pressure Selection Table

Spec		DS-05	DS-10	DS-20	DS-30	DS-50	DS-80	DS-100
Dis. Capacity (mL/min)	50Hz	45	99	206	287	435	698	984
	60Hz	55	120	250	350	530	850	1200
No. of stroke (SPM)	50Hz	48	96	96	113	96	158	238
	60Hz	58	116	116	138	116	193	290
Max.dis Pressure (kg/cm ²)			10(15)		8(10)	10	5	3
Motor 15W, 25W, 40W	Output(W)	15(25)			25(40)	40	40	40
	1Φ	110V, 220V / 1Φ (Standard)						
	3Φ	220V, 380V, 440V / 3Φ(Order made)						
Joint Hose		Φ6 X Φ9					Φ9XΦ13	
Accessories		FOOT VALVE 1PC, ANTI-SIPHON CHECK VALVE 1PC ※SUS304, SUS316, TEFLON: Special (Order made)						
		HOSE 3M						
Weight (kg)		ABOUT 4.0					ABOUT 5.0	

DS Series

특징 및 주의점

- 1) 감속기에서 유량조절 레버까지의 일체형 구조 실현으로 무소음, 무결점 펌프의 시대를 창조하였습니다.
- 2) 일체형 구조 실현으로 내구성이 극대화 되었습니다.
- 3) 콤팩트한 설계로 사용 및 보수유지가 간편합니다.
- 4) 사용액의 온도는 0~50℃입니다.
- 5) 사용액의 점도는 50cp이하 입니다.
- 6) 펌프 사용시 주위 온도는 0~40℃입니다.
- 7) 배관접속방식 : Hose type(기본), Flange(주문) 가능
- 8) 상기 사양은 개량 등의 이유로 예고없이 변경될 수 있습니다.

Features & Cautions

- 1) Dong-il MT has created a time for silent and no defects pumps which unitary structure from geared motor to adjustment lever of liquid volume.
- 2) Maximized life with uniformed structure.
- 3) It is easy to use and maintain by compact design.
- 4) Using temperature : 0~50℃
- 5) Using viscosity : Below 50cp
- 6) Room temperature for pump : 0~40℃
- 7) Connecting type : Hose type(standard), Flange(optional)
- 8) Above specifications are that should be changeable due to improvement etc without any notice.

Head Structure 헤드 구조도

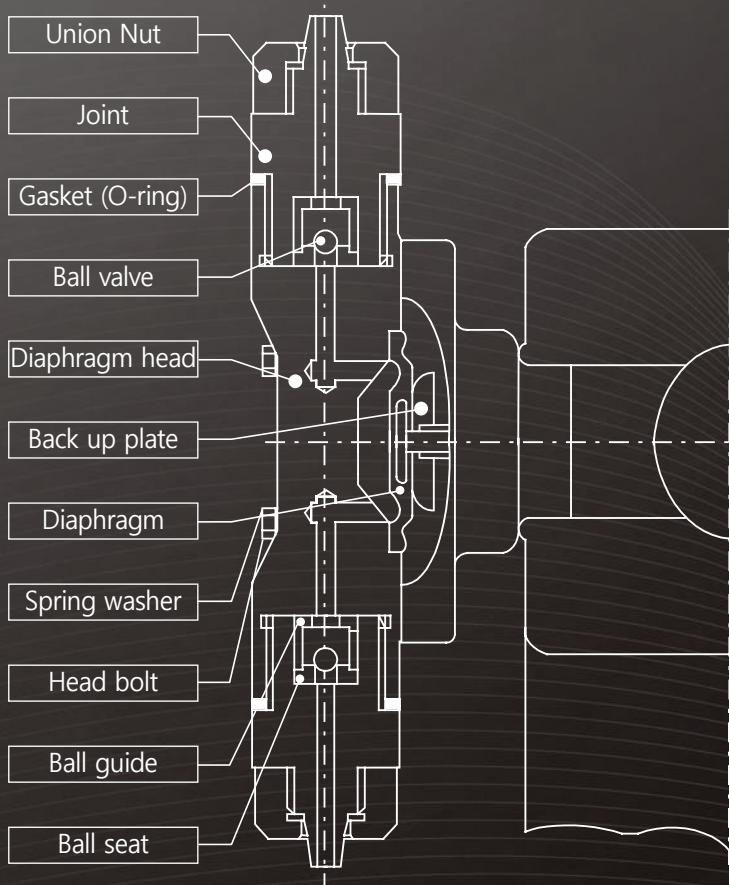

No.	Symbol of material	PVCE	S7S7	S2S2	P4CE
1	Diaphragm head	PVC	SUS304	SUS316	PTFE
2	Diaphragm	PTFE /EPDM	PTFE /EPDM	PTFE /EPDM	PTFE /EPDM
3	Ball valve	CERAMICS	SUS304	SUS316	CERAMICS
4	Valve seat	PVC	SUS304	SUS316	PTFE
5	Ball guide	FPM	SUS304	SUS316	PTFE
6	Joint	PVC	SUS304	SUS316	PTFE
7	Union nut	PVC	SUS304	SUS316	PVC
8	Gasket	PTFE	PTFE	PTFE	PTFE
9	Hose	PVC	PVC	PVC	PTFE

Application

- ① Swimming pool
- ② Septic tank
- ③ Sterilizing water
- ④ Simple prepared water
- ⑤ Water treatment
- ⑥ Feeding antiseptle
- ⑦ City waste water
- ⑧ Feeding various medical fluid

○ 외형도(Dimension, Unit/mm)

< DS05-DS50. Motor=15W >

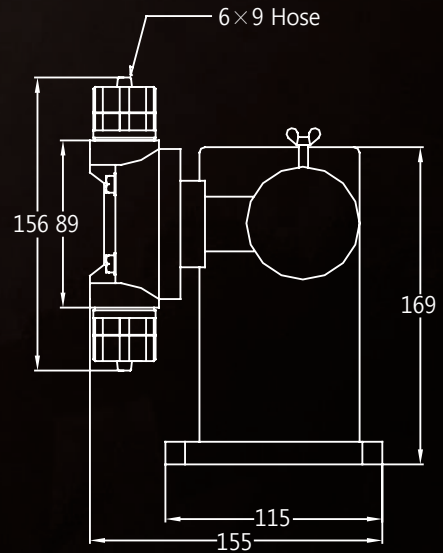
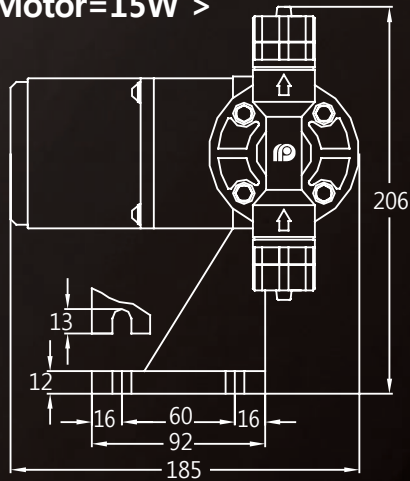

< DS80-DS100. Motor=40W >

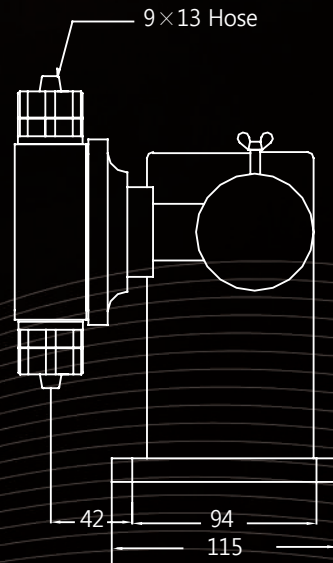
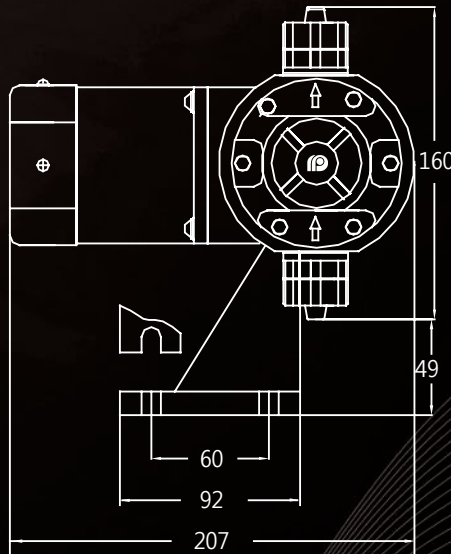

○ Anti-Siphon Check Valve / Foot Valve

< Anti-Siphon Check Valve >

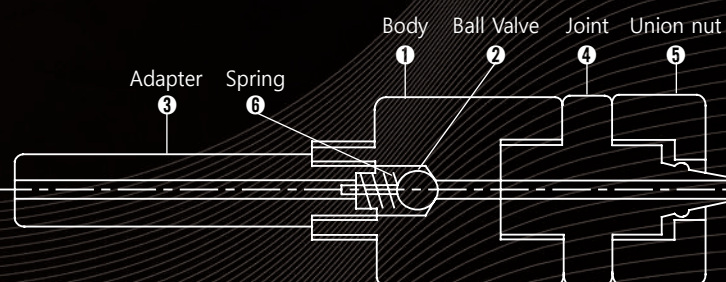

< Foot Valve >

