

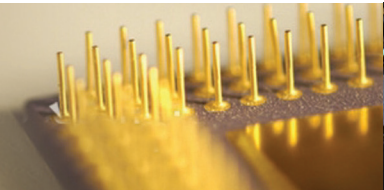

# 092 SERIES

SINGLE STAGE HIGH-FLOW  
LOW PRESSURE NPT TYPE





## FUNCTIONAL SCHEMATIC

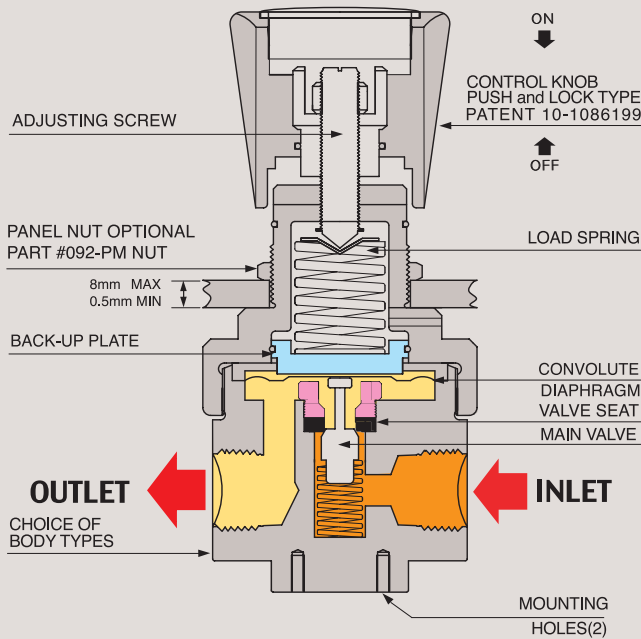

## FLOW CHART

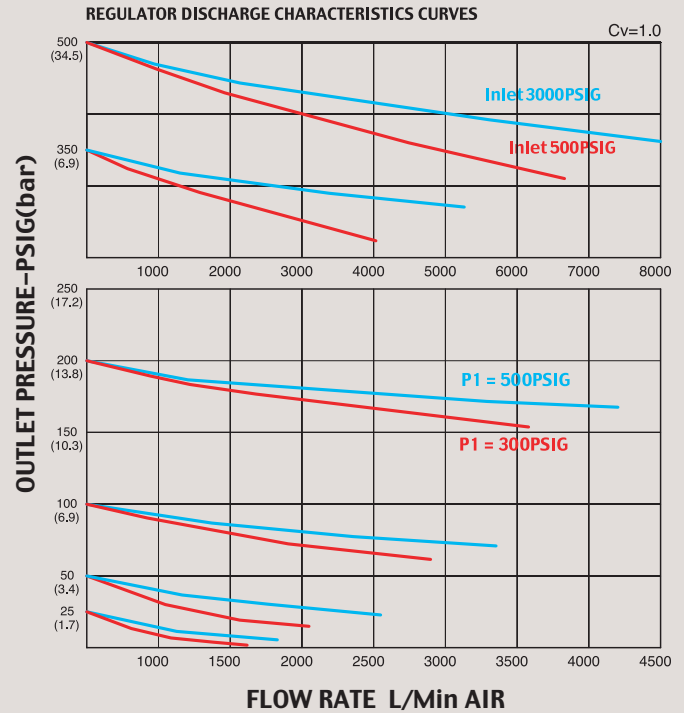

### Single Stage High-flow Low Pressure NPT type (1/2")

092시리즈는 정밀 배관 라인에서 고 유량을 필요로 하는 작업환경에서 가장 많이 사용되는 1/2" NPT type Pressure Reducing Regulators입니다.

- 본체와 내부의 모든 부품은 Stainless Steel 316L로 이루어졌으며, 일반가스 라인, Bulk Gas Line, 실험실, 분석용 특수 가스, 또는 고순도 가스, 믹싱용 가스, 그리고 부식성 기체와 액체 등에서 모두 사용할 수 있도록 설계 제작되었습니다.
- 입구 압력은 최대 3600psig(250bar)이고 출구압력은 모델에 따라 5psi(0.3bar) ~ 최대 500psig(35bar)까지 사용할 수 있고 용도에 따라 2-ports, 3-ports 또는 4-ports를 선택 가능합니다.
- 사용 중 가스라인이나 외부의 미세 진동 등으로 인하여 초기 압력 셋팅 값이 미세하게 변동하는 현상을 완전히 해결한 당사 Push and Lock 조절 손잡이 (당사 특허 # 10-1086199)를 적용하여 사용하기에 더욱 편리합니다. 조절 손잡이를 누르면 (lock) 압력 셋팅 값이 변하는 것을 완전히 방지할 수 있고, 손잡이를 앞으로 당기면 (unlock) 자유롭게 원하는 압력으로 다시 셋팅 할 수 있습니다.

※ 주의 : 크린라인이 아닌 일반 라인에 사용 할 경우 반드시 필터링(gas 7 $\mu$ m~15 $\mu$ m, water 15 $\mu$ m~80 $\mu$ m)을 하여야 하며, 그렇지 않을 경우 바로 고장의 원인이 됩니다. 모든 제품은 필터링하여 사용하면 A/S 비용 절감과 제품의 수명연장에 많은 도움이 됩니다.

### SPECIFICATIONS

Ports	1/2" NPT type Gauge Ports 1/4" NPT
Leak Rate Certification	to 2x10 <sup>-8</sup> atm cc/sec Helium available.
Body Material	Stainless steel 316L
Bonnet Material	Nickel Plated Forged Brass/stainless steel 316L
Diaphragm	Stainless steel 316L
Main Valve	Stainless steel 316L
Valve Spring	Stainless steel 316L
Valve Seat	Teflon® (Kel-F, Polyimide, etc.. Optional)
Inlet Pressure Ranges	092-0000-1S, 3,500psig (238bar) 092-0000-1S-5, 500psig (35bar)
Outlet Pressure Ranges	25(1.7bar), 50(3.5bar), 100(7bar), 200(14bar), 350psig(24bar)
Self-Venting	092-0000-1S-V Optional
Operating Temperature	-40° C - +70° C (-40° F - +160° F) (standard) 092-0000-1S-H1, +120° C (Optional) 092-0000-1S-H2, +250° C (Optional)
Flow Capacity	Cv=1.0 (Cv=1.2 Optional)

**REFERENCE**

This catalogue is printed as of January 2018, and the dimensions and/or specifications in this catalogue can be changed without prior notice in the course of constant upgrading and improvement of our products.

**INSTALLATION DIMENSIONS**  
METRIC EQUIVALENTS ARE IN PARENTHESES

■ GAUGE PORT OPTIONS

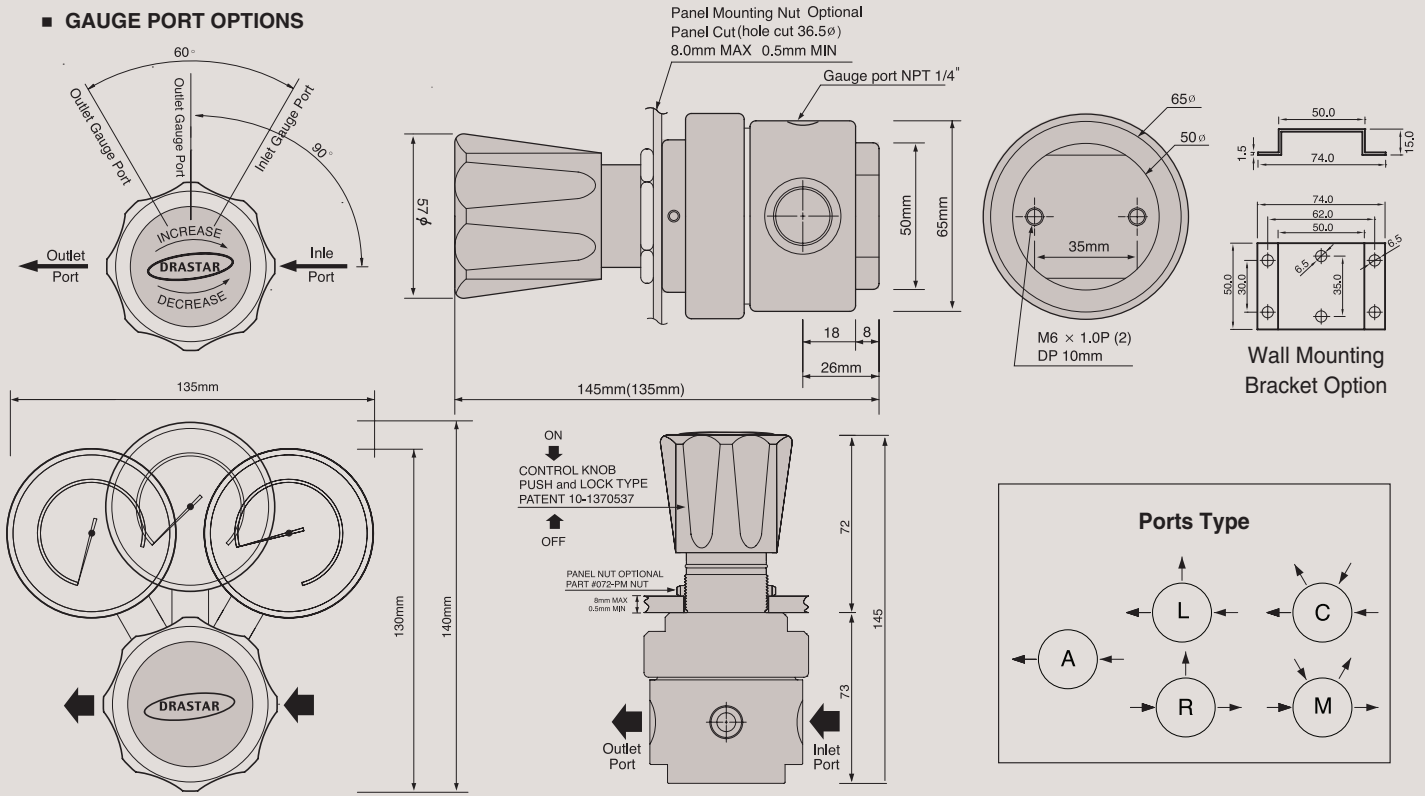

**092 Series is a 1/2" NPT type single-stage pressure reducing regulator specially designed to use for high-flow low-pressure applications. Made of stainless steel for body and all internal parts, 092 series has wide range of applications.**

With DRASTAR's patented (patent #1086199) "push and lock type handle", you can operate it easily and stably; "locking" by pushing down the handle will prevent any slight change of pre-set pressure value, which could possibly be caused by any vibration from gas pipeline or ambient applications and the other way "unlocking" by pulling it back enables you to adjust the pressure value freely again.

**Features & Applications**

- 1/2" NPT type high flow low pressure regulator
  - Inlet pressures are 3600psi(250bar) or 600psi(42bar) and outlet pressures are 25psig (1.7 bar) ~ 500psig (35bar)
  - Panel mounting nut or wall mounting bracket available as option • Design proof pressure: 150% of maximum rated
  - Applicable for general gas line, bulk gas line, research labs, specialty gases for analytical application, high purity gases, mixing gases, and corrosive gases as well as liquids.
- ※ DRASTAR's all pressure regulators are assembled, cleaned, inspected, and packed in clean-room equipped with clean bench, helium detector, particle counter, ultrasonic cleaner, ultrapure water system, vacuum packaging machine, etc. through oxygen cleaning procedure in compliance with process and regulations indicated in CGA 4.1. and or ASTM G-93 and are free of any grease or oils.
- ※ **Caution:** Filtering (gas 7 $\mu$ m~15 $\mu$ m, water 15 $\mu$ m~80 $\mu$ m) is a MUST to use in the general gas application other than high purity gases. Otherwise, it may cause a failure to the regulators. It is strongly recommended to install filter for extension of life span and saving the maintenance expense

**ORDERING INFORMATION**

**(W)092 - 0025 L - 1S H - 5 - V - H1**

BASIS SERIES NUMBER	OUTLET PRESSURE RANGE	PORT TYPE	FLOW CAPACITY	DIAPHRAGM MATERIAL	INLET PRESSURE	SELF VENTING	HIGH TEMPERATURE
Standard Inlet Pressure 3600psig (250 bar)	0025 = 25psi(1.7bar) 0050 = 50psi(3.5bar) 0100 = 100psi(7bar)	A = 2-Ports L = 3-Ports C = 4-Ports	1 = 1/2" Female NPT  1S = Cv 1.0 Standard	STS 316L Standard  H = Hastelloy-C	5 = Inlet 600psi(42bar)  Optional	V = Self-Venting  Optional	H1 = 120° C H2 = 250° C H3 = 350° C  Optional
Body : STS 316L Only	0200 = 200psi(14bar) 0350 = 350psi(24bar) ※ 0500 = 500psi(34bar)	R = 3-Ports M = 4-Ports					

※ Note : 1) (W) model is only for liquid and water. 2) ※ 500psi model must be used for W model only. 3) H1, H2, H3 option is not available for brass products.



## 092 SERIES PART LIST

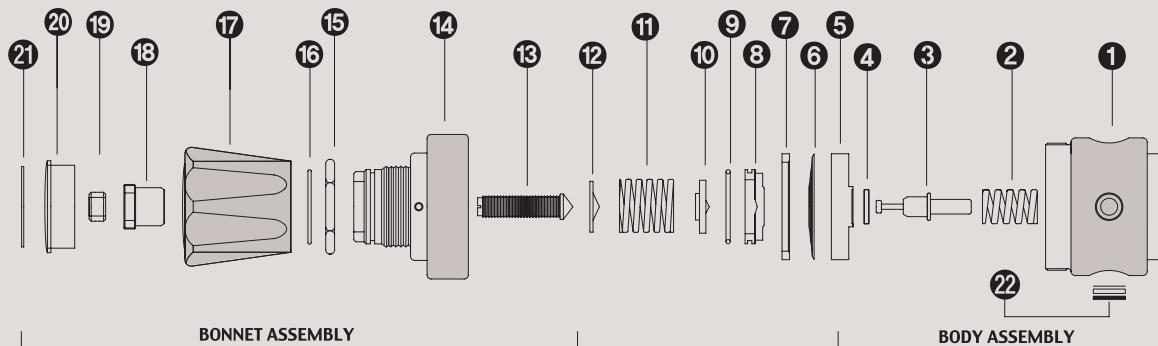

## STANDARD MODEL SERIES

Item No.	Description	Part No.	Model Application
01	Body	092-02-01	02-01 Stainless steel 316L
02	Valve spring	092-04-01	All Model Same
03	Main Valve	092-06-01	All Model Same
04	Valve Seat	092-10-01	All Model Same
05	Locking Plate	092-14-01	All Model Same
06	Diaphragm	092-16-01	16-01 STS 316L / 16-02 Hastelloy C-22
07	Diaphragm Plate	092-22-01	All Model Same
08	Back-up Plate	092-26-01	All Model Same
09	Back-up Plate O-ring	092-26-00	All Model Same
10	Spring Plate	092-30-01	All Model Same
11	Load Spring	092-38-01	38-01 25psi/38-02 50psi/38-03 100psi/38-04 200psi/38-06 350psi/38-07 500psi
12	Pivot	092-40-01	All Model Same
13	Adjusting Screw	092-42-01	All Model Same
14	Bonnet	092-44-02	44-01 STS 316L / 44-02 Brass
15	Panel mount Nut	092-48-01	All Model Same
16	Push & Lock O-Ring	092-46-01	All Model Same
17	Control Knob	092-50-01	50-01 ABS / 50-04 Aluminum Control knob
18	Push & Lock Handle nut	092-52-01	All Model Same
19	Locking Nut	092-54-01	All Model Same
20	Name Cap	092-56-01	All Model Same
21	Name Cap Plate	092-58-01	58-01 25psi/58-02 50psi/58-03 100psi/58-04 200psi/58-06 350psi/58-07 500psi
22	Filter Assembly	092-60-03	All Model Same